

FIRST OPERATION OF A SUPERCONDUCTING PROTON ACCELERATOR

A. Brandelik, A. Citron, P. Flécher, J.L. Fricke, R. Hietschold
G. Hochschild, G. Hornung, H. Klein(*), G. Krafft, W. Kühn,
M. Kuntze, B. Piosczyk, E. Sauter, A. Schempp(*), D. Schulze,
L. Szecsi, J.E. Vetter, K.W. Zieher
Institut für Experimentelle Kernphysik
Universität und Kernforschungszentrum
Karlsruhe, Germany
(*Institut für Angewandte Physik
Universität Frankfurt, Germany

presented by
A. Citron

Introduction

At Karlsruhe, the first section of a superconducting proton linear accelerator has been operated successfully in the first half of this year.

I shall review briefly the purpose and the concept of the accelerator under construction in our laboratory. Then I shall describe some of its components and give some results on the performance of the accelerator during the first tests. More details will be given in two talks this afternoon on the accelerating structure, its rf-behaviour(1,2) and on the rf-control circuits (3,4).

The pioneering groups at Stanford have concentrated their efforts mainly on the acceleration of electrons. At Karlsruhe, we felt that it would be useful to attack the complementary problems of acceleration of heavier particles. Our main perspective is the acceleration of protons to energies above 500 MeV for the abundant production of pions. The limiting currents for protons and electrons are about the same, but the production of pions per primary is about a thousand times higher for protons than for electrons. It is almost redundant to state at Los Alamos that abundant pion production is interesting both for fundamental research and for other applications, amongst which radiotherapeutical ones play an important part. It should be remembered, that in Europe only one meson factory is presently under construction, namely the SIN Zyklotron at Villigen near Zürich, which is intended to have a 100 μ A cw proton beam.

Adoption of completely new technology usually involves some surprises and we thought it would not be wise to meet these surprises in the course of constructing a large accelerator. Therefore it was decided to build a small pilot accelerator at Karlsruhe with a final energy in the region of 50 MeV and a current of 1 mA with the purpose of provoking all the problems involved in a larger superconducting proton accelerator. Solutions could then be developed and demonstrated and a reliable cost estimate could be derived from the experience made with the pilot accelerator.

The main difference between proton and electron accelerators lies in the low energy part where heavy particles are comparatively slow. Therefore we have concentrated our efforts at present on the low velocity section of our accelerator. This section presents some additional interest, because the results obtained here are directly relevant to heavy ion accelerators.

Injection

We decided to start with an injection energy of 750 keV ($\beta=0.04$) because well tested inexpensive Cockcroft-Walton sets with easily accessible strong ion sources are available at this energy.

TABLE I

INJECTOR

Type	Cockcroft-Walton
Insulation	Normal air
Energy	800 keV
Ion source	Duoplasmatron
Proton current	2 mA
Emittance (normalized)	0.12 π cm mrad for 80% of the beam

Table I gives some important parameters of the injector. Fig. 1 shows a general view of the injector.

Choice of frequency and structure

The main problems for the low energy section are the short periodicity imposed by the synchronous condition, the defocusing action of the accelerator and problems of beam break-up. All these problems become more difficult with increasing frequency and by putting in figures it can be shown that they are all serious. For these reasons there is a preference for operating at low frequency.

On the other hand, low frequency structures are generally of large dimensions and it would not be easy to fabricate them out of superconducting material. These considerations made us look for a low frequen-

cy structure of modest dimensions. The neighbourhood of Frankfurt, where a strong group had accumulated experience with helix accelerators since many years, finally tipped the balance in favour of the helix structure (5).

Helix structure

Fig. 2 shows a drawing of the helix structure as it was used in the first section of our accelerator and table II gives

TABLE II

FIRST ACCELERATING STRUCTURE

Injection Energy		750 keV	
Operating frequency at room temperature	}	low field	
at 1.8 K			90.77 MHz
Design field on axis (TW)			90.92 MHz
Static frequency shift at design field		1.155 MV/m	
Peak electric field		690 kHz	
Peak magnetic field		15 MV/m	
Number of niobium helices		437 Gauß	
Length of a $\lambda/2$ helix		5	
Pitch of helix		7 - 9 cm	
Radius of helices		about 1 cm	
Electrical length of coupled array		3.7 - 4.2 cm	
Design Energy gain at optimum phase		36.8 cm	
Radius of outer cylinder (lead plated copper)		424 keV	
Length of outer cylinder		20 cm	
		58.5 cm	

some parameters of the helix, which is operated at a frequency of 90 MHz. It is seen that the transverse dimensions are quite small. The radius of the outer tank is not critical. The value shown in the table was chosen for technical reasons and could well be made still smaller. Details on the construction of the resonator, the preparation of the niobium helices and its performance will be given in the papers by Dr. Vetter (2) and Mr. Fricke(3) presented this afternoon. I shall only mention, that the 5 niobium helices are each half wave long, that they are mechanically independent and electrically strongly coupled. The design energy gradient of 1.155 MeV/m (which is 1 MeV/m over the cosine of 30°) is a conservative value. Energy gradients between 2 and 3 MeV/m are compatible with the fields reached in laboratory experiments on helix loaded resonators, where maximum fields up to 1000 Gauß were measured(6).

The energy gradients that can be reached in a helix structure, are not very high due to an unfavourable peak field to accelerating field ratio. This drawback is directly related with the advantage of concentrations of field in small regions. Also the shunt impedance of the helix drops off towards higher velocities. Therefore, for a large accelerator another type of structure operated at higher frequency has to be used as soon as one has passed the region where

low particles velocity create the difficulties mentioned above. This jump in frequency at a transition from one type of structure to the other requires a buncher providing short bunches of particles at the entrance of the accelerator. We will come back to the problems of the buncher below.

Focussing

As it was mentioned above, focussing is a problem in the first part of a proton linear accelerator. Focussing inside an accelerating structure as it is practised with the Alvarez accelerator is not feasible in a superconducting structure. Therefore, quadrupole focussing between accelerating tanks has been foreseen. Some parameters of the focussing system are given in table III.

TABLE III

Lattice	T F D T F D T O F D
T	accelerating tank
O	straight section for pumps
Doublet length	30 cm
Half aperture	3 cm
Max. gradient	30 T/m
Norm. Admittance based on 2 cm half aperture	0.8π cm rad

In order to reduce the technical length, it is advantageous to include the focussing elements in the cryostat and to make them superconducting in order to avoid heat dissipation at low temperatures. The stray fields from the quadrupoles are shielded from the accelerating tanks by superconducting lead shields. Moreover the lenses are energized only after the cavities have become superconducting, so no flux can penetrate into them. The lenses are energized from a dc supply, but when the desired current has been reached, a superconducting switch is closed so that they work in short circuit and can be disconnected from the power supply.

Cryostat

I shall now describe the cryostat(7) that houses both the accelerating section and the lens. A 3 m long cryostat was used. It is shown in Fig. 3. It can accommodate 3 accelerating sections and 3 lenses. For the present tests, 2 accelerating sections and 2 lenses were replaced by dummies. Wide twin pipes at the top of the cryostats serve as helium reservoirs. They are filled with helium at 1.8 K from a 300 W refrigerator built by German Linde. The superfluid helium is fed through pipes to the helices and also to cooling channels in the outer cylinder of the resonators. No circulation of helium is needed; the internal convection mechanism in superfluid helium is sufficient to eliminate the heat developed in the resonators. All parts at 1.8 K are superisolated, moreover a liquid nitrogen shield is provided to minimize radiation losses.

The cryostat has about 15 W of heat losses. The beam vacuum is separated from the insulation vacuum. The beam vacuum is maintained by ion getter pumps that continue to work at low temperature. The beam vacuum is nowhere in contact with a joint on the helium system which minimizes the problem of leaks. As a matter of fact, a super-leak developed when we cooled down below the λ -point which deteriorated the insulation vacuum, but affected the beam vacuum only little.

Chopper-buncher-system

The need for a buncher was already mentioned. For a conventional accelerator it is sufficient to bunch a high fraction of the particles into the phase acceptance offered by longitudinal phase space. Particles outside this acceptance are eliminated in the first part of the accelerator. In the superconducting accelerator, such loss of particles in the structure cannot be tolerated for two reasons.

- 1) Dissipation of heat at low temperature. If 10% of a 1 mA beam would be lost at 1 MeV, 100 W of heat would be dissipated in the first section, which is an order of magnitude higher than the rf losses in the superconductor. Losses at the frequen-

cy jump at higher energy are even more serious.

- 2) Radiation damage in the superconducting surfaces. The dose rate corresponding to the example quoted above would be in the order of 10^8 rad/h; Halama(8) claims radiation damage has to be expected at doses of 10^8 rad.

So clearly the losses have to be reduced very significantly. A chopper-buncher-system providing short bunches with clean spaces in between has been designed(9). Unfortunately, due to a trivial failure it was not operating during the accelerating test.

RF Controls

Finally, I'll make a few remarks about an essential component of the rf system, namely the rf controls, about which you will hear a lot more this afternoon. Some of the problems connected with the superconducting helix accelerators are due to the poor mechanical stability of the helix. It has two consequences.

- 1) External vibration transmit themselves to the helix and cause mechanical vibrations, which in turn shift the resonant frequency of the cavity. This jitter can be as high as 100 kHz peak to peak, but it can be reduced by suitable mechanical damping to about 3 kHz, or 3×10^{-5} of the resonant frequency.
- 2) The rf fields can induce mechanical vibrations above a certain field level(10).

This is connected with the asymmetric shape of the resonance curve in a system, where the resonant frequency is shifted under the influence of the rf fields in the cavity (fig. 4). The drawn curve shows the resonance curve for the case, where the static frequency shift is well in excess of the bandwidth. It can be shown, that instability against transfer of energy from electrical to mechanical energy can occur on the upper side of this resonance curve, whereas on the lower side there is stability. But clearly a working point on the lower side can only be chosen, if there is a dynamical control of phase or amplitude.

By suitable choice of the parameters of the feedback system the coupling between electrical and mechanical oscillations cannot only be prevented from giving rise to instabilities, but it can actually be used for damping existing oscillations of the same frequency. In tests with one cavity it is possible to dynamically adjust the transmitter frequency to the cavity frequency by a phase control system. Dr. Schulze will report details on the system this afternoon and also the steps foreseen for operating two and more cavities(3).

Results of first runs

I will terminate by listing the most important results on the two periods of operation in March and June 1972. Fig. 5 shows the accelerator in its operating state.

- 1) Stable operation of a proton beam (1.3 μ A) was demonstrated for several hours at an accelerating field of 1.30 MV/m, which is higher than the design value of 1.155 MV/m. The beam was limited to 25 μ A by the rf coupling device, that was not designed for transmitting high power.
- 2) Maximum accelerating fields of 1.40 MV/m could be achieved; the limitation occurred in the rf control circuits.
- 3) The superfluid cooling was adequate.
- 4) An accidental vacuum failure made the Q-values of the resonators drop dramatically. After simply warming up the structure, evacuating and cooling it down again, the original peak fields and Q-values were reproduced.
- 5) Non-resonant beam break-up was investigated using a method developed in our institute (11). Starting current for such break-up will in any case be higher than 0.5 mA.
- 6) The effects of mechanical vibrations of the helix, even though they were surprisingly large, could be controlled by suitable electronic circuits.

In November of this year, we hope to do our next major tests. The following additional features should be studied in this and subsequent periods.

- (a) Operation of two accelerating cavities.
- (b) Use of a strong rf coupling, permitting a higher beam current.
- (c) Operation with a bunched beam.



Fig. 1 View of the 800-keV injector

When these objectives will have been reached, we feel that the specific problems of a helix accelerator for protons will be solved.

References

- 1) J.E. Vetter, B. Piosczyk, J.L. Fricke, these conference proceedings, p. 145.
- 2) J.L. Fricke, B. Piosczyk, J.E. Vetter, these conference proceedings, p. 151.
- 3) D. Schulze, S. Brandelik, R. Hietschold, G. Hochschild, A. Hornung, F. Spielböck, J. Szecsi, these conference proceedings, p. 156.
- 4) C.M. Jones, J.L. Fricke, B. Piosczyk, J.E. Vetter, these conference proceedings, p. 163.
- 5) C. Passow, Proc. 7th Intern. Conf. High Energy Acc., Yerevan, II 606, 1970.
- 6) A. Citron, J.L. Fricke, C.M. Jones, H. Klein, M. Kuntze, B. Piosczyk, D. Schulze, H. Strube, J.E. Vetter, N. Merz, A. Schempp, O. Siart, Proceedings 8th Intern. Conf. High Energy Acc., CERN, Geneva, 278, Sept. 1971
- 7) W. Barth, P. Flécher, F. Graf, M.A. Green, W. Herz, L. Hütten, H. Katheder, W. Lehmann, F. Spath, G. Winkler, Proceedings 4th Cryog. Eng. Conf. ICEC 4, Eindhoven, May 1972
- 8) H.J. Halama, Appl. Phys. Letters 19, 90 (1971)
- 9) K.W. Zieher, Nucl. Instr. and Meth., to be published
- 10) D. Schulze, Karlsruhe, KFK-report 1493, 1971
- 11) K. Mittag, M. Kuntze, F. Heller, J.E. Vetter, Nucl. Instr. and Meth., 76, 245 (1969)

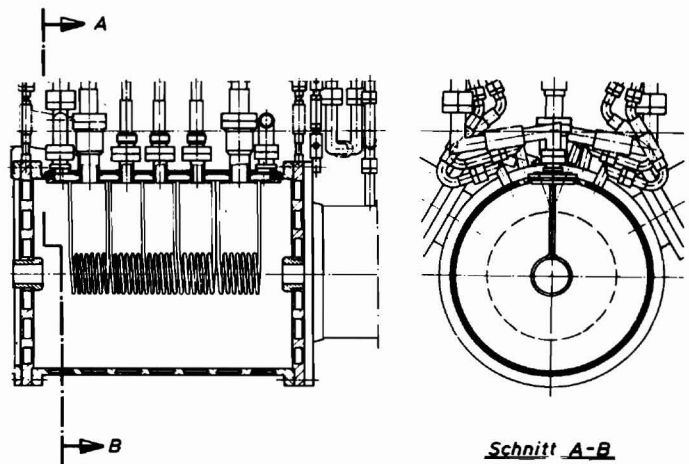

Fig. 2 The accelerating section

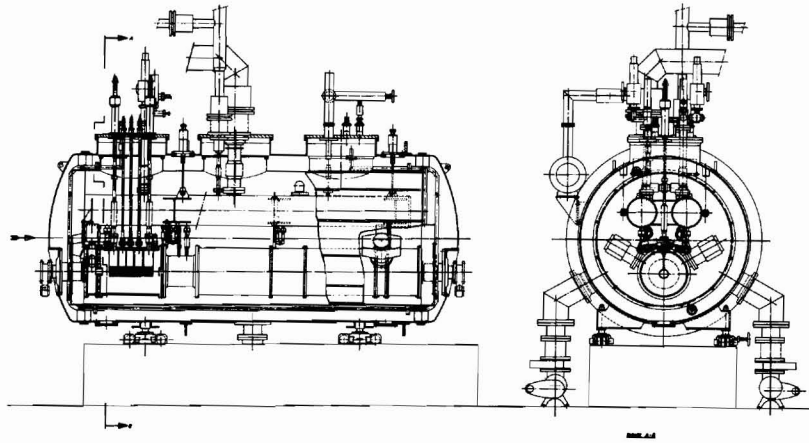

Fig. 3. The cryostat.

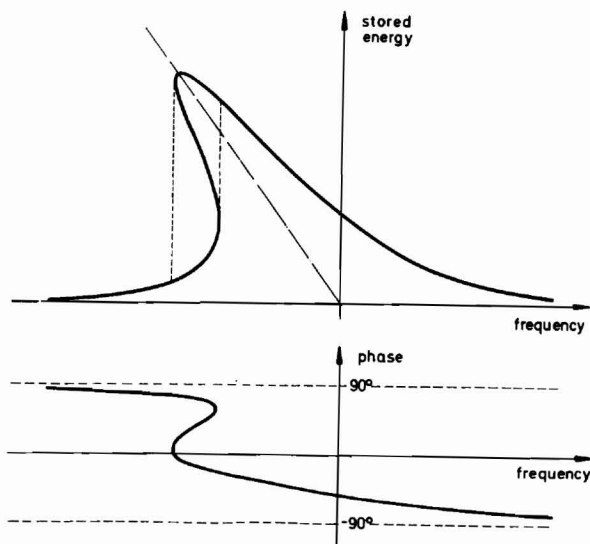

Fig. 4 Resonance curve of the helix resonator at high field levels.

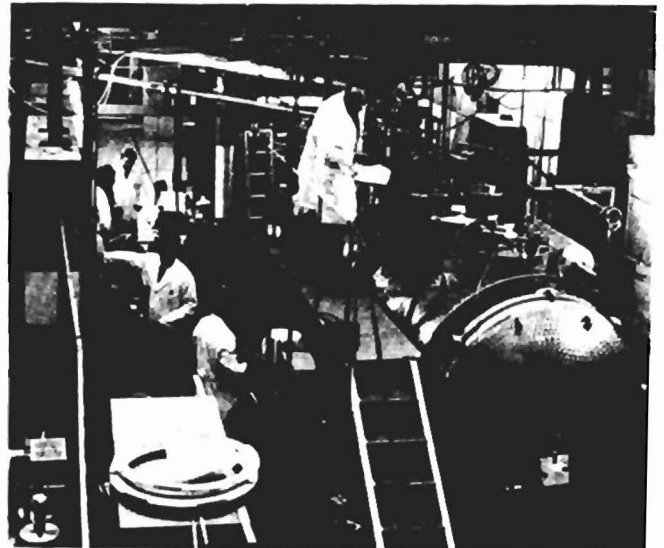

Fig. 5 Overall view of the accelerator.

DISCUSSION

Panofsky, SLAC: Could you remark about beam break-up? You said you made experiments up to .5 mA, but you only accelerated 1 μ A.

Citron: One need not accelerate anything to find the excitation of the parasitic modes by sending a small beam through.

Question: Does bunching make a difference?

Citron: No. We tried this in an analog model, but this is nonresonant beam breakup. It depends only on average current and on particle velocity and phase velocity of the wave in question.

Miller, SLAC: Bunching does not offset anything unless the bunching frequency is related to the unwanted mode.