

BEAM DIAGNOSTICS AT THE BNL 200 MeV LINAC*

N. Fewell and R. Witkover
Brookhaven National Laboratory
Upton, New York

Introduction

As one of the newest generation of Linacs, the BNL 200 MeV machine and its low and high energy beam lines was designed to allow for an adequate amount of the most advanced diagnostic equipment. This was not only desirable to achieve the high performance requirements of the beam, but also necessary due to its potentially destructive capabilities. This paper describes the types of equipment installed, their location, performance and the measurements for which they were used.

Equipment Design Considerations

Among the general considerations which influenced this type of instrumentation were:

a) Whenever possible the lack of, or use of equipment, should not be the cause of beam loss.

b) The diagnostic equipment should operate over the full range of beam parameters, i.e.

$$1 \text{ mA} \leq \text{beam current} \leq 100 \text{ mA}$$

$$1 \text{ } \mu\text{s} \leq \text{pulse length} \leq 200 \text{ } \mu\text{s}$$

$$1 \text{ p.p.s.} \leq \text{pulse rep. rate} \leq 10 \text{ p.p.s.}$$

c) The electronics should operate remote from radiation areas, i.e. outside the tunnel.

d) All instrumentation should be capable of operation with or without computer control or readout.

e) Measurements of the beam's physical parameters should include: current, position and profile.

f) Measurements of the beam quality should include: transverse emittance, mean energy and energy spread.

Requirement (a) is of greatest concern, since beam loss not only prevents delivery to the user, but may also present a serious radiation hazard as well. At the moment certain measurements are only possible using destructive devices (i.e. devices that change the downstream beam parameters), if the necessary resolution is to be achieved. However, with enough on-line, non-destructive instrumentation in the system, most beam parameters can be monitored sufficiently well to ensure delivery of high quality beams. The use of destructive devices being limited to study periods, or when a fault condition exists that prevents the AGS from accelerating the beam.

Equipment Location

For beam diagnostic purposes the Linac is split into three major areas: the low energy beam transport (LEBT), the accelerating tanks, the AGS and BLIP (Brookhaven Linac Isotope Producer) high energy beam transport (HEBT) lines. The layout of the complete system is shown in Fig. 1.

1. Low Energy Beam Transport

The low energy beam transport line is relatively long compared with that of most linacs; this is necessary in order to match the existing high gradient column to tank 1 (1) and also to match a future beam line from a second Cockcroft-Walton pit. The LEBT line contains five viewing boxes (VB1 - VB5) each of which houses a beam transformer. An additional beam transformer is mounted after the second buncher. Probes that measure emittance and beam profile in both planes are normally mounted in VB1 but these units may be moved to boxes VB2 to VB4. Two more units are nearing completion and will be normally mounted in VB4. Similar units are mounted permanently in VB5. VB1 also contains a beam stop so that studies can be made on the high gradient column independent of the low energy beam transport system. Viewing box VB2 contains an electrostatic beam chopper, the unwanted part of the beam being stopped on a water cooled collimator in VB3. This collimator will shortly be changed for a four jaw box. The LEBT line also contains a double bunching system that operates at the fundamental frequency of the machine. This bunching system is also used to measure the energy change with time, of the preinjector beam.

2. Accelerating Tanks

Sandwiched between tanks 1 and 2, which are bolted solidly together, is a small drift space of approximately 5 in. Into this space we have inserted a beam transformer and two emittance probes similar in design to those used in LEBT. At the exit of each of the remaining tanks is an rf gap and a viewing box which contains a beam transformer and a secondary emission monitor (SEM's T2 to T9) single wire scanner. These SEM's are used to measure beam profile and position.

3. AGS and BLIP High Energy Beam Transport (HEBT) Lines

The linac group is responsible for transporting the beam through the AGS HEBT line as far as bending magnet 5, with the AGS group taking responsibility for the remaining 110 ft to the AGS inflector. This line contains twelve beam transformers, seven beam position monitors, six SEM scanners, a plunging slit and two multiwire SEM units. The BLIP line contains an additional six beam transformers, four SEM scanners and a fixed

*Work performed under the auspices of the U.S. Atomic Energy Commission.

multiwire ion pickup unit.

The SEM's in the AGS HEBT have been placed to allow the calculation of the 200 MeV emittance from four beam profile measurements (SEM's H1 to H4). In addition SEM's H5 and H6 are located at the planes of a 1 to -1 transformation, and since SEM H6 is located at a point of maximum momentum dispersion, while SEM H5 is before the bending magnet, they are used to provide a measure of energy spread in the beam. A fixed multiwire SEM and a position monitor are also located at this point to give momentum spread monitoring on each pulse and mean energy as a function of time within the pulse. During study periods a slit that degrades and scatters the unwanted part of the beam can be inserted at SEM H5. The energy spread can then be more accurately measured using a motor driven multiwire SEM that has a much finer pitch than the fixed unit.

Equipment and Measurement Description

1. Current Transformers

Beam intensity is monitored in more than thirty locations in the Linac and transport lines using toroidal beam transformers. The transformers are usually located within the vacuum chamber and have produced no noticeable outgassing. Amplifiers are located outside the beam tunnel to eliminate radiation effects and allow convenient servicing. All signals are sent to the control room for display and data logging. The transformer-amplifier units have 50 mA/V calibrations in LEBT and 20 mA/V in the rest of the machine. Signal rise times of 250 ns can be observed. The droop time constant is 15 msec. The signal noise level is less than 0.1 mA equivalent voltage.

Figure 2 shows a transformer of the type used in LEBT and between cavities. It is 3 1/8 in. clear ID and 1 in. thick exclusive of BNC connectors. The core is of 4-79 mo-Permalloy (T9033-P2) (2) 2 mils thick tape, 4 in. ID with 1/2 in. x 1/2 in. cross section. The bare core is coated with a thin layer of epoxy to allow winding the coil without shorting to the core. The winding is a single layer of 200 turns of #32 heavy Formvar magnet wire. After winding the core is placed in a spun copper electrostatic shield, 1/16 in. thick, to which the connector block has been soldered. An annular cover plate is then put over the can and electron beam welded along its outer circumference. The inner circumference has a 0.005 in. gap to the spinning which was machined down, to provide the necessary dielectric break. The welded unit is then vacuum impregnated with epoxy(3) and the filling hole sealed with a silver loaded conductive epoxy to complete the electrostatic shield. The completed unit has only this 1/4 in. hole and the 0.005 in. gap presenting exposed epoxy to the vacuum. A version of the same design with a 1 in. greater diameter is used in the HEBT and BLIP lines. Measurements of inductance of the smaller transformer yield values of 0.750 H and a resistance of 1.6 Ω . A single turn test loop is also wound around the transformer and terminated in 100 Ω . This is used for calibration purposes.

All transformers use the same amplifier design. The LEBT transformers differ only in their

setting resistor values. The circuit is shown in Fig. 3. The amplifier is a differential input wideband dc amplifier with 50 Ω input impedance and 50 Ω line driving capability. The 50 Ω input impedance allows the remote placement of the amplifier from the transformer by matching the coaxial cable impedance; however, it reduces the droop time constant from 300 msec to 15 msec.

Since the amplifiers are located at various distances from the control room (as much as 700 to 800 ft) the output cable resistance differs from unit to unit and may represent a sizable percentage of the 50 Ω characteristic impedance. Since all cables are matched at the receiving end this forms a voltage divider for the amplifier output signal. To accommodate this effect and allow for tolerances in amplifier gain, the terminating resistor is a potentiometer with the position of the wiper determining the calibration. All transformers may be calibrated from the control room by means of a precisely set 100 mA pulsed current source which may be distributed to the transformer under test by a wafer switch selector. The calibrate pulse is synched to the beam pulse and delayed from it so that both the beam signal and calibrate pulse may be displayed on the same trace.

2. SEM Profile Monitors

To provide accurate information on the shape and position of the beam between tanks in the HEBT and BLIP lines, single wire scanning devices have been installed. Similar units have been described at the 1970 Proton Linac Conference.(4) These units provide a high resolution, inexpensive but relatively slow method of obtaining data. This data is obtained by measuring the secondary electrons removed by the beam from 0.001 in. tungsten wires that are stepped through it. Between the cavities the wire is moved in steps of 0.25 mm for a complete scan of 4 cm. In the high energy lines, step size is doubled to 0.5 mm and the range increased to 7 cm. These units can be driven singly or in groups by a manual system or shortly, by the computer.

Logic is also included to interrupt the motor stepping pulse when a "center" microswitch is reached, if the mode is selected in which the wires are placed in the center of the beam pipe. Stepping of the motors may be either for every linac pulse or for only AGS' pulses, since the AGS will receive only one of every ten pulses at the maximum linac rate.

The desired signal is produced by the loss of secondary emission electrons from the wire. The signals indicate a conversion efficiency of 3 to 4% at the end of cavity 2 (39 MeV) and 1 to 2% at 200 MeV. Biasing the wires with up to 90 V with either polarity showed no noticeable increase in signal. This effect is not fully understood.

The signal coming from the wire shows a strong rf component when the wire passes particular positions in the vacuum chamber. These signals are not dependent upon beam position but occur only when beam is present, indicating that the viewing box forms a resonant cavity for the beam harmonics. Two copper spoilers have been added

in an attempt to prevent the probe arm acting as a $\lambda/4$ TEM resonator (Fig. 4). The spoilers serve to break up the H field in this mode. The use of rfi filters on the signal lines has reduced the unwanted signals to a tolerable level.

The signals are amplified by electronics located outside the beam tunnel. By matching the input impedance of the amplifier to the cable, the signal rise time is not affected by cable length. The amplifier (Fig. 5) consists of two FET-input, hybrid operational amplifiers in cascade, with a net gain of 1250. An emitter follower included in the feedback loop of the second stage provides the ability to drive the long cable back to the ICR. By capacitively coupling between the two stages drift and offset problems are eliminated. The rise time of the amplifiers is under 5 μ sec. Typical signal currents are from 10 to 50 μ A.

3. Multiwire SEMS

While the high resolution of the single wire SEM's is desirable, it is often more advantageous to trade resolution for rapidity in taking data. This may be done by the use of an array of many wires placed in the beam pipe at the desired location. The signals from the array may be sampled, stored and scanned electronically to produce the beam profile from a single beam pulse.

To reduce cost, cut production time and conserve the space available for diagnostic installation, the wire arrays are mounted on the same drive yokes as the single wire SEM's. (Fig. 6). An array consists of thirty tungsten wires spaced 1 mm apart in both the horizontal and vertical planes. The wire diameter is 0.001 in. except at location SEM H6 where the unit is to be used following a slit. In the multiwire mode of operation the SEM drives are run to their full depth into the beam pipe. In this position the center wires of the arrays are in the beam pipe centers. The drive units remain in this position as long as data is being taken. At the present time three of the SEM units have been converted to multiwire units; the remaining SEM's will be converted as machine downtime and manpower permit.

Two preliminary fixed multiwire units have been installed in the linac output lines. One unit consists of twenty wires over a 10 cm span and is located at SEM H6. Comparison of displays obtained with this unit and a single wire SEM is shown in Fig. 7.

The second unit was placed in the BLIP line to the Chemistry experimental area and is located outside the vacuum system. This unit employs sixteen wires in each of the horizontal and vertical planes, with the amplifiers being switched by means of multipole relays. Since these wires are in air, the signals are due to positive ion collection rather than secondary electron emission. A strong dependence on bias voltage and beam pulse width is observed, in contrast to the vacuum unit in which no such effect was ever noted. Considerable enhancement of the signal was possible by increasing the positive bias voltage applied to foils located fore and aft of the arrays. Usable profiles were obtained with beam current as low as 1 to 5 mA and pulse widths of 1 to 2 μ sec.

The multiwire SEM electronics system schematic is shown in Fig. 8. In addition to the amplifiers each multiwire electronics unit contains sample and hold circuits (one per channel) and an analog multiplexer. Since horizontal and vertical signals will be taken simultaneously, duplicate amplifiers, sample and hold circuits and multiplexers are required. A multiplexer interface card provides the link between the unit and the control room. It contains differential receivers to accept the commands to activate the sample and holds, and the multiplexer readout clock pulses, which cause the multiplexer to advance channels. There is also logic circuitry to program the multiplexers to readout the horizontal array sequentially, followed by the sequential readout of the vertical array data. This card also contains a gain of 2 buffer amplifier/line driver to send the signals to the control room.

4. Emittance Probes

The low energy emittance probe together with its operational electronics and displays were fully described at the 1970 Proton Linac Conference.(5) These probes have been run successfully for the past two years with little damage to the probe heads. No pickup array has failed and only one slit plate has been re-machined. Surface melting of the tungsten plates occurs at 750 keV and flakeing occurs at 10 MeV, Fig. 9, but in either case little or no damage is done to the slit area.

These units are now interfaced with the PDP-8 computer. Probes for measuring the emittance at 200 MeV are now under construction. These units will consist of a slit that degrades and scatters the unwanted beam, and a pickup head 48 in. downstream from the slit. These will be stepped synchronously across the beam by stepping motors in a similar manner to the existing low energy probes. The pickup unit is a multiwire SEM having thirty .001 in. tungsten wires spaced .016 in. apart with a biased .00025 aluminum foil shielding the wires from the beam rf.

Non-destructive Emittance

While it is possible to make emittance measurements at 200 MeV in much the same manner as has been done at lower energies(6), the long beam transport lines at the end of the linac make possible a non-destructive estimate. This technique makes the assumption of an elliptical emittance and the measured profiles are sometimes clearly not gaussian. It does provide an on-line monitor of beam quality which can be used to detect deviations from desired beam behavior, at which time the higher resolution but destructive measurement would be used to actually determine the emittance.

The computation makes use of four profiles transformed to a common location, with a variational technique being used to determine the best fit values to the three emittance parameters. Comparison to results obtained by the destructive method indicate good agreement with the emittance area, although the ellipse eccentricity and orientation do not always correlate. This may in part be due to a difference in time between when the measurements were made.

5. RF Buncher Energy Monitor

The 200 MHz buncher system used at BNL is described elsewhere.(7) The double bunching system lends itself very well to the measurement of the energy change of the 750 keV beam, due to loading of the 750 kV power supply system. This measurement is made by switching off the rf applied to the second buncher, bunching the beam with buncher #1, and measuring the phase difference between the rf applied to buncher #1 and the beam induced rf from buncher #2.

Results of a typical measurement with and without the Haefely buncher system are shown in Fig. 10.

6. Beam Position Monitors

The beam position monitors used in the HEBT were designed by J. Claus.(8) These monitors consist of a ferrite window frame in which there is a copper pickup loop, (Fig.11). A positive or negative voltage at 'AB' is obtained when the beam is off center, due to an unbalance of the currents induced in the two side arms of the loop. The copper pickup loop is formed by 3/16 in. copper plates hard soldered together. For times less than the diffusion time the magnetic flux lines due to the beam current are forced to be tangential to the walls thus improving the linearity. This design also results in independence from vertical beam position within the loop.

The signal current induced in the single turn copper strap is fed to the primary winding of a transformer which is used to match the impedance of the loop to the twisted pair cable used to carry the signal to the remotely located electronics. Outside the beam tunnel the signal is received by a differential input amplifier with good common mode rejection. Since the resulting L/R of the device and cable is so low, an integrator must be used to restore the signal dependence upon position of the centroid. A driver stage then sends the signal to the control room.

The units are 3 in. wide throughout the HEBT except at position 7, i.e. after bending magnet 4 where we have a 4 in. unit. At this point the dispersion is 7.6 cm/% $\Delta P/p$. The calibration of the unit at this point is 6.6 mV/in/mA, and for a typical 50 mA beam we usually set the beam on axis to within .02 mV i.e. approximately 1.5 mm. The normal maximum deviation from the axis with time is about ± 4 mm i.e. $\pm \Delta P/p \pm .05\%$.

Data Processing and Displays

It was not found practical to have a computer available to the linac at the time of initial turn on. For this reason all instrumentation was designed for manual control by the operators and real time data processing and display with hard-wired electronics. However, since the desirability and eventuality of computer control and processing was so clear, all equipment was designed to minimize the interfacing problems in the future. Now that the conversion to computer control is taking place we find that the dual control has several benefits: 1) the amount of "control" required of the computer is considerably lessened, easing the burden

upon the machine and speeding up operation, 2) manual operation may be used when the computer is unavailable and 3) since the system was originally intended for manual use the video signals are probably more readily accessible for viewing than in a system designed for purely computer monitoring. The various displays available to the operator at present, and those expected in the immediate future will be described.

Beam current information is now displayed in two forms: as video waveforms and as a digital display of the current at a pre-settable sample time. Any two transformer signals may be selected by means of a push button keyboard which controls a multipole relay tree. The video waveforms are displayed on variable persistence scopes while the same signals are sampled and displayed on a DVM. The actual signal voltages or their difference or ratio may be selected on the DVM. The sampling is performed once prior to beam arrival and again during the pulse and the difference taken to eliminate baseline errors. Soon to be installed is a dual multiplexer chassis which samples all transformers simultaneously (also with baseline subtraction). This unit will allow the operator to select a beam histogram by means of the same keyboard push buttons. It will also be computer addressable to provide beam current information for data logging.

The outputs of the scanning wire SEMs are displayed on storage scopes. The horizontal position is established by an up-down counter driving a digital to analog converter. The vertical sweep is the wire output signal. Sampling is achieved by modulating the beam intensity to display only at the desired sample time. To display both the X and Y profiles on a single run, the vertical input is switched from the Y profile to the X profile automatically when the motor starts in reverse. At the same time, the counter is set to count down, providing the proper horizontal sweep. Profiles at up to four locations can be simultaneously displayed. The computer controlled mode is planned for installation at a later date. In this mode up to eight separate units may be selected for running and the data stored in the computer. These may then be used to compute emittance in the high energy lines.

The two existing multiwire SEMs are the forerunners of some twenty units to be eventually installed. At present both units can be viewed on oscilloscopes and one, the HEBT 6 unit can be read into the computer. This data can be used to provide an on-line measure of mean energy and energy spread since it is located at a point of maximum dispersion. When the slit located in H-6 is used to limit the beam emittance for higher resolution energy spread data, the computer uses this input to control the bending magnet current and the phase of a given cavity to automatically produce phase-energy and phase-energy spread plots.

In the future when all twenty multiwire units are installed on SEM drives, it is expected that they will be run in groups of up to eight at once, with data from all eight (both planes) being taken into the computer on every beam pulse.

Destructive emittance measurements have been made both manually and by computer control.

In the manual mode many runs are needed before a full set of emittance contours are obtained whereas in the computer mode only one data run is needed to provide all the desired output information.

At present a PDP-8L with an 800,000 word disk is being used. It is more than adequate for the data taking and storage but lacks speed in computation. In the near future access to the AGS PDP-10 will be possible via the PDP-8 and any large scale computation will be performed there. At present the only data output device is the relatively slow teletype but an alphanumeric graphic display terminal is now being brought on line and should eliminate this time consuming step. A typical teletype printout of emittance, profile and emittance vs beam current is shown in Fig. 12.

Acknowledgment

We wish to thank I. Weitman for his knowledgeable help and advice in interfacing this equipment to the computer and also the Linac technicians for their patience and skill in assembling and installing the various units; their efforts are sincerely appreciated.

References

1. C. Agritellis, R. Chasman and Th. Sluyters, "Design of the Low Energy Beam Transport System of the BNL 200 MeV Injector Linac" Proc. 1969 Particle Accelerator Conference.
2. Manufactured by Arnold Engineering Co., Marengo, Ill.
3. 70% Shell Epon 815, 20% Shell Epon 870, 10% DTA, R. Damm private communication.
4. R.W. Goodwin, et al, "Beam Diagnostics for the NAL 200 MeV Linac" Proc. 1970 Proton Linear Accelerator Conference, p. 107.
5. R.L. Witkover and N. Fewell, "Automatic Electronic Emittance Device for the BNL 200 MeV Linac" ibid p. 125.
6. A. van Steenberg, et al, BNL Internal Report
7. N. Fewell, "Buncher RF System" Particle Accelerators to be published.
8. J. Claus, BNL Internal Report.

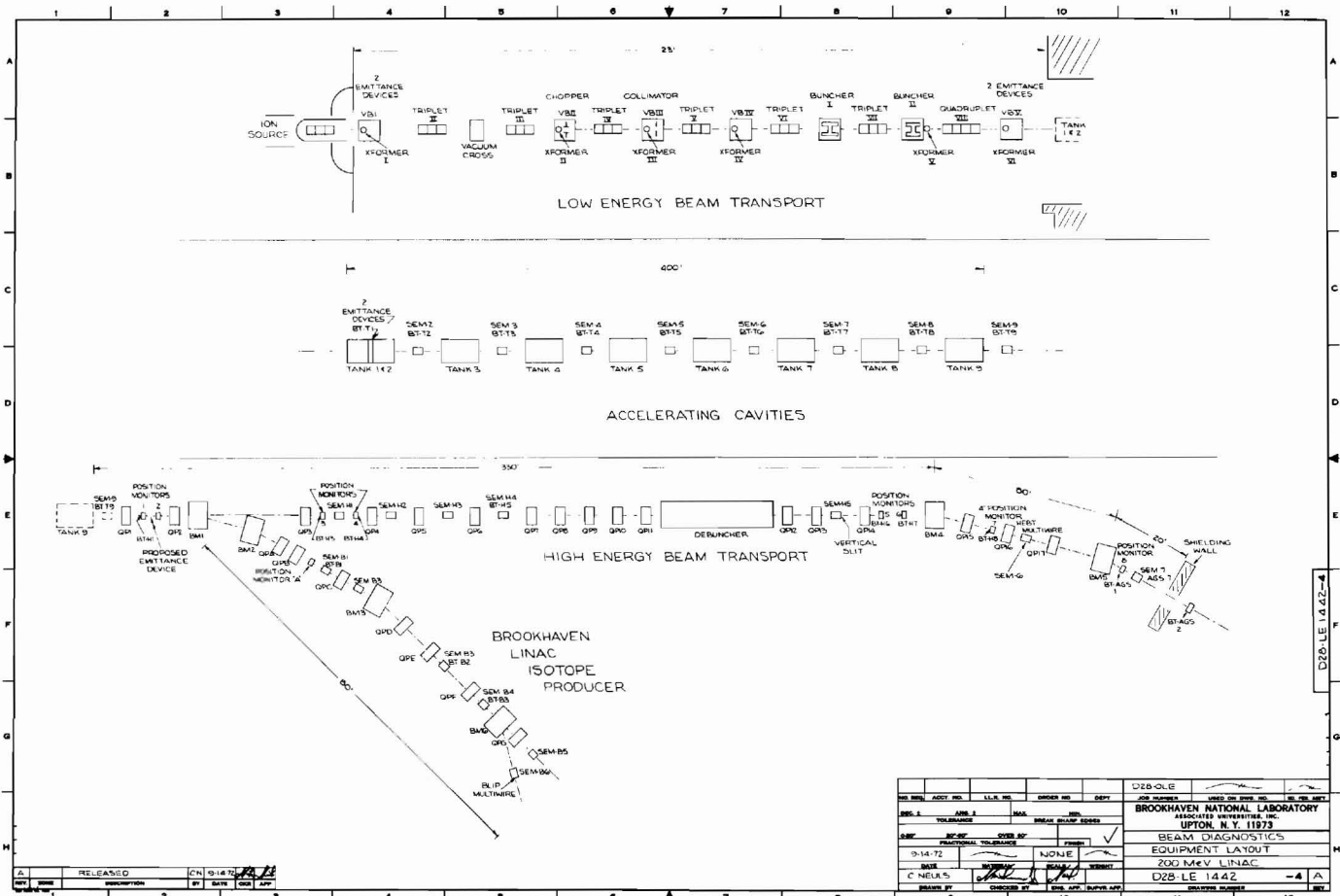

Fig. 1. Beam Diagnostic Layout.



Fig. 2. 3-in. Beam Transformer,

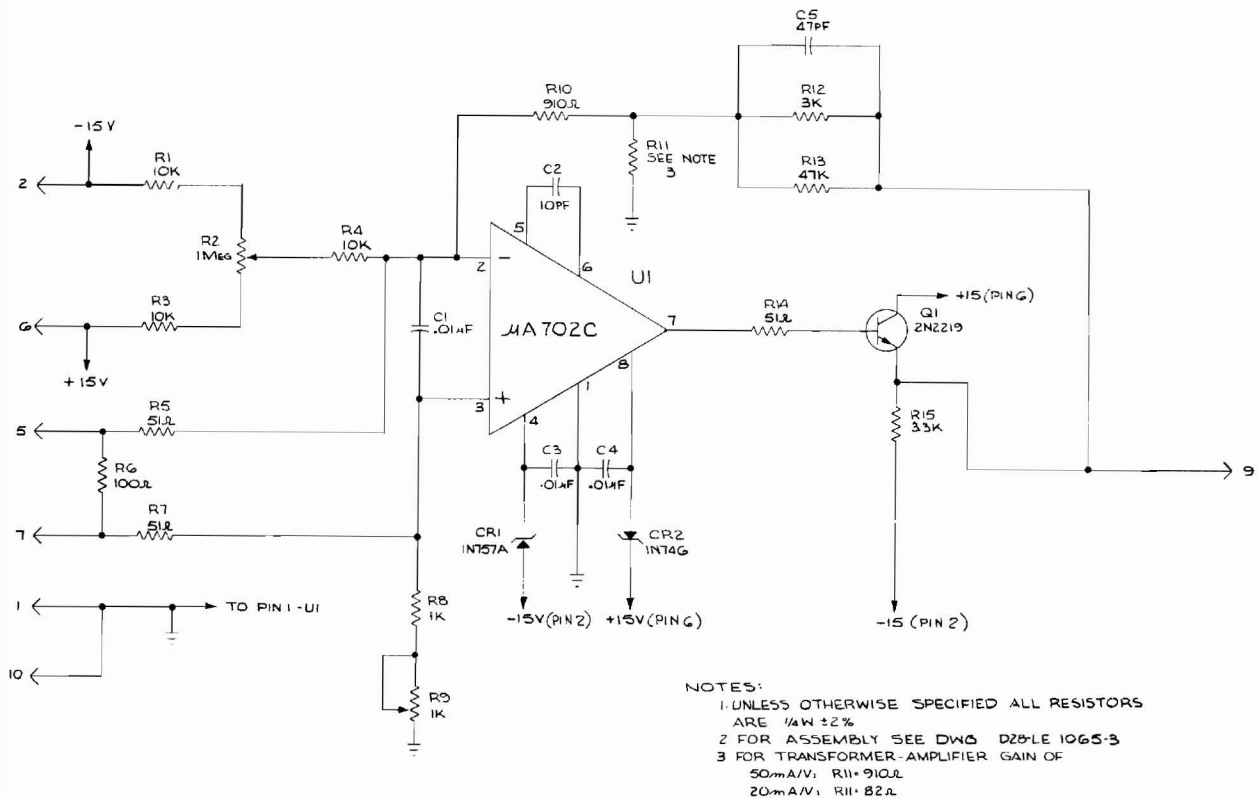

Fig. 3. Beam Transformer Amplifier Schematic.

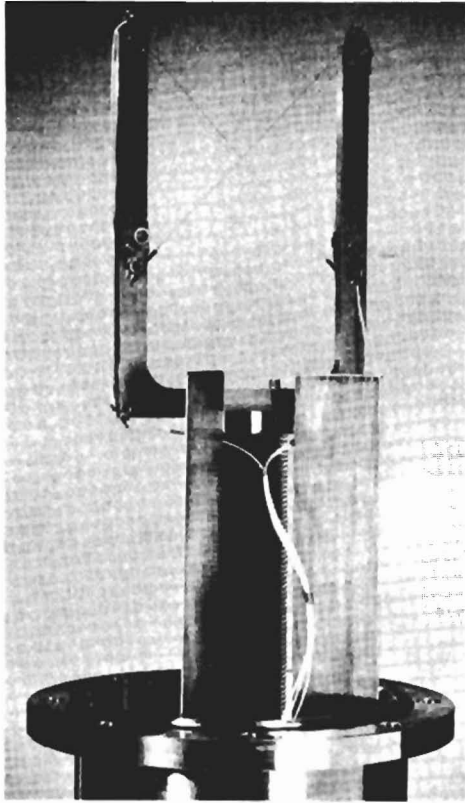

Fig. 4. Single Wire SEM

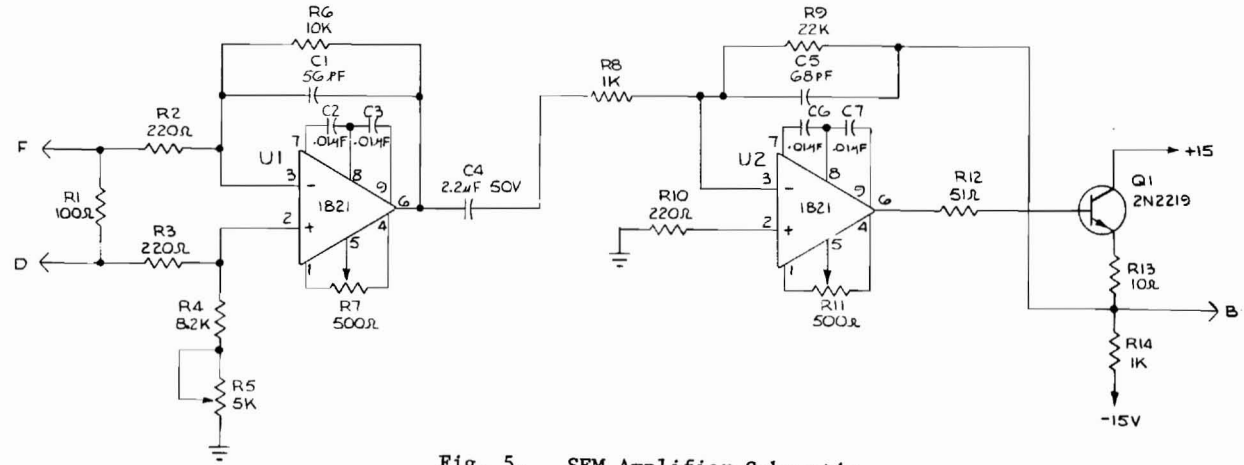

Fig. 5. SEM Amplifier Schematic

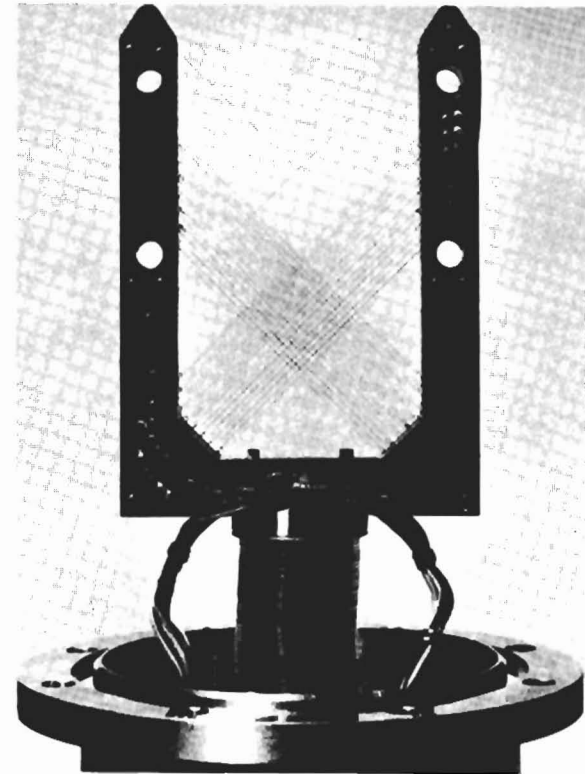
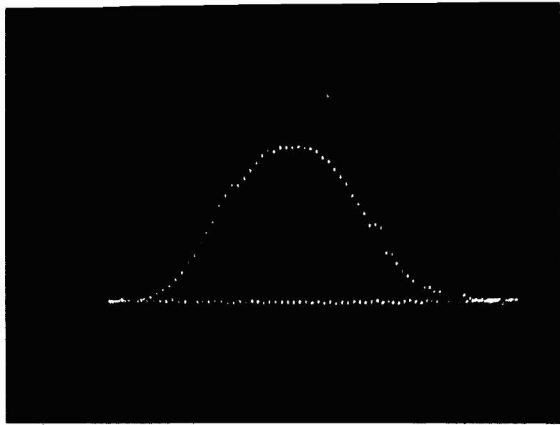
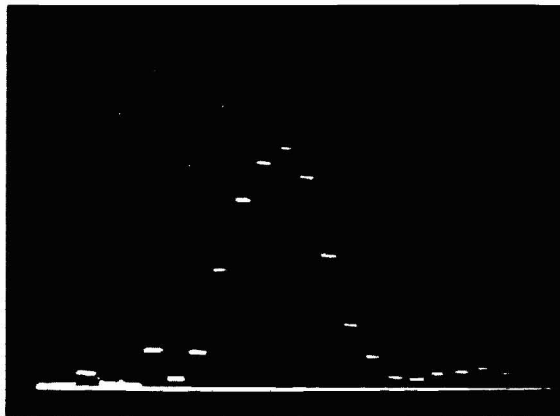

Fig. 6. Multiwire SEM



SINGLE WIRE SCAN. POSITION HEBT 6
2.6 CM FWHH (0.5 MM/STEP)



MULTI WIRE MONITOR POSITION HEBT 6
2.6 CM FWHH (5 MM/CHANNEL)

Fig. 7. Single and Multiwire SEM Displays.

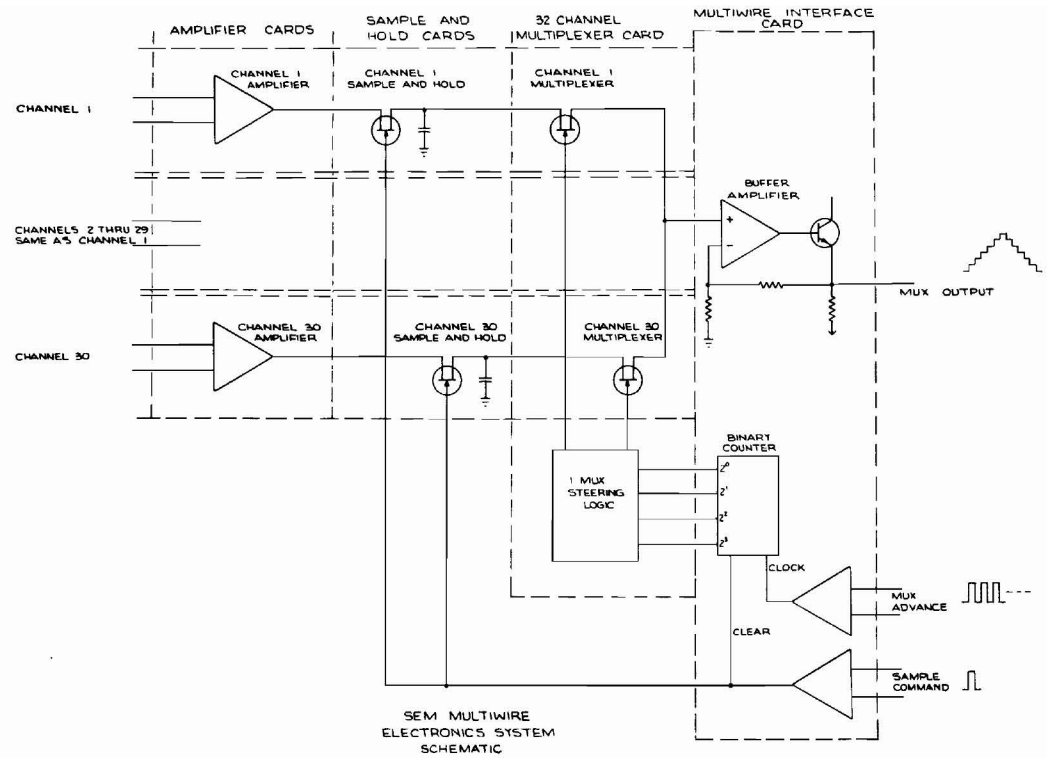

Fig. 8. Multiwire SEM/Electronics System Schematic

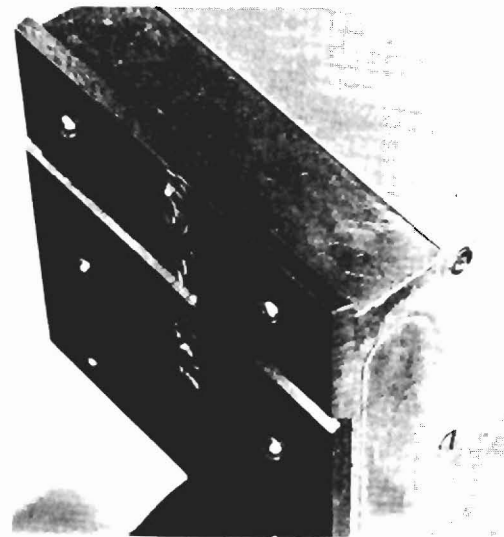
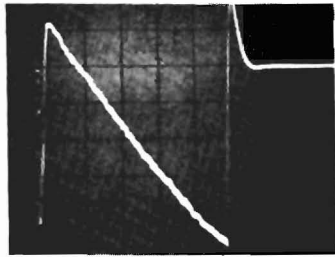
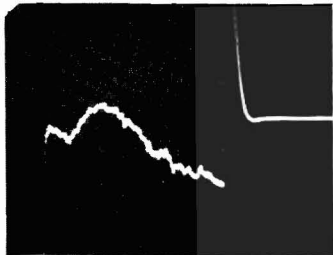

Fig. 9. 10 MeV Emittance Head.



ALL DATA ON LOG VS TIME NO BUNCHES
IN THE BEAM, ONLY ONE BUNCH



ALL DATA ON LOG VS TIME NO BUNCHES
IN THE BEAM, ONLY ONE BUNCH

Fig. 10 Energy Measurement Using the RF Bunchers

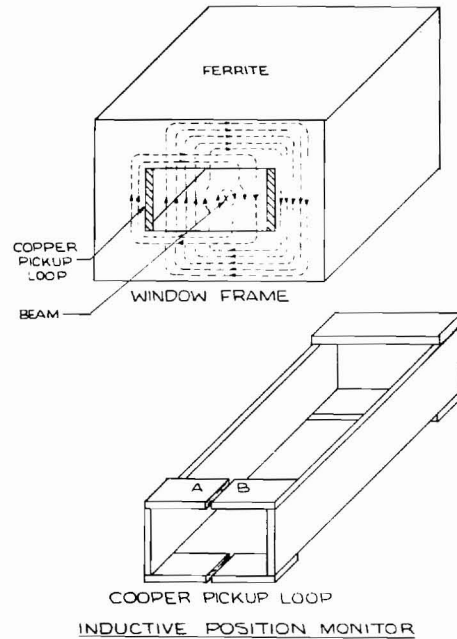

Fig. 11 Beam Position Monitor

```

EMITTANCE VS. BEAM CURRENT
EMITTANCE UNIT LOCATION      10MEV
PLANE OF MEASUREMENT        HOP-
EMITTANCE UNIT NUMBER       3
BEAM CURRENT IN MILLI-AMPS.  95
THRESHOLD STEP SIZE IN MILLI-VOLTS.  18
NOISE LEVEL IN MILLI-VOLTS.  1
UPPER LEVEL IN MILLI-VOLTS.  258

COPY THIS MESSAGE...

0 1 DSK:(FILE NAME)IGOTO 2-12
*0 1 DSK:(TIME)IGOTO 2-12
    
```

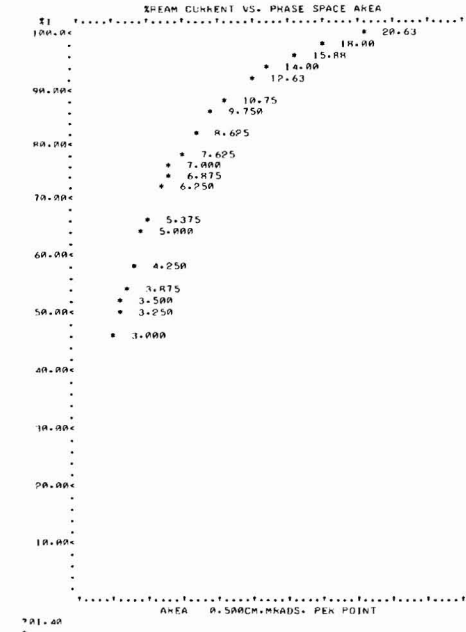

```

L K EMPLOT
PROFILE SCALE MV/STAK ? 58
LOCATION LMS TKF HOK ? TANKI
PLANE VERT. HOK ? HOK
CAL FACTOR .125
NUMBER OF SCANS ? 74
THRESHOLD 18

COPY THIS MESSAGE...

0 1 DSK:(FILE NAME)IGOTO 1-11
*0 1 DSK:(TIME)IGOTO 1-11
    
```

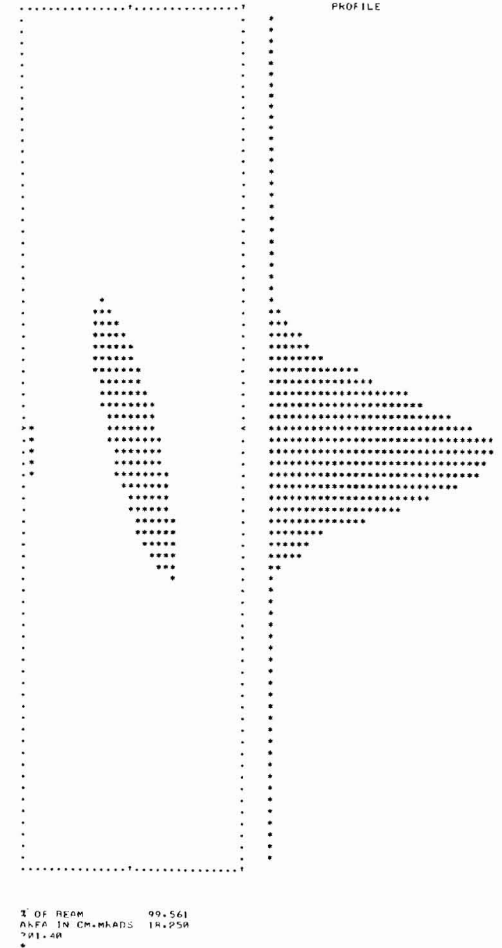

Fig. 12 Typical Teletype Printout