

## TWISTED, MULTIFILAMENT Nb<sub>3</sub>Sn SUPERCONDUCTIVE RIBBON

Willard D. Coles  
Lewis Research Center  
Cleveland, Ohio

### Abstract

An experimental study of superconductor stabilization has resulted in the successful application of the concepts of filamentary structure and conductor twist to Nb<sub>3</sub>Sn ribbon. The Nb<sub>3</sub>Sn is formed in parallel, helical paths, which are continuous around the ribbon. Short lengths (12-18 cm) of 1.27 cm wide superconductive ribbon have been produced. The filamentary and twist characteristics are incorporated in the ribbon by means of an inert mask formed on the ribbon surface early in the fabrication process. Diffusion reaction of the niobium and tin is prevented at the filament boundaries. Described are the conductor methods of fabrication, and test results obtained. The technology required to adapt the processes for the production of long lengths of ribbon is available.

### Introduction

Because of the excellent work of many theorists, experimenters and materials fabricators, e.g., references 1 to 5, high-field superconductive materials have been improved at a very rapid pace in the scant 10 years of their commercial existence. Many of the "coil degradation" problems of the early years were solved for the ductile alloys with adoption of the concepts of copper matrix composites, multifilaments, and twisted conductors. The brittle intermetallic superconductors have been made flexible and have been strengthened with stainless steel and stabilized with copper and aluminum. The attainment of a twisted, multifilament configuration for the intermetallic compounds has, however, been elusive.

The use of very fine, insulated filaments in a composite conductor has been shown to provide an intrinsic stabilization resulting from a more favorable dissipation of heat. By imparting a twist to the filaments, the path length of induced magnetization currents is reduced, which limits the energy available locally to quantities which can be absorbed at lower temperatures (ref. 4). Magnetization currents in a superconductor are field-induced circulating persistent current loops. These currents are in addition to the transport current and may be many times higher in current magnitude.

The very thin ribbon geometry developed to provide flexibility for the brittle intermetallic compound superconductors, unfortunately, is particularly subject to induced magnetization currents. With no means available to limit the current loop path length in ribbon conductors, the loops can become very long and contain considerable energy. The effects of these persistent current loops are (1) increased likelihood of

transition to the normal state, (2) high residual field values (field remaining in a magnet after the power supply current is reduced to zero), (3) variable current-field relationship (history dependent), and (4) variable field homogeneity.

The obvious improvements realized with the ductile alloy composites led to an experimental study with the purpose of applying the multifilament and twist concepts to Nb<sub>3</sub>Sn ribbon. These characteristics have been successfully incorporated into short lengths (12-18 cm) of 1.27 cm wide Nb<sub>3</sub>Sn ribbon. The Nb<sub>3</sub>Sn is formed in parallel, helical paths which are continuous around the ribbon. The filamentary and twist characteristics are incorporated in the ribbon by means of an inert mask formed on the ribbon surface early in the fabrication process. Diffusion reaction of the niobium and tin is prevented at the inert mask forming the filament boundaries. Described are the conductor, methods of fabrication, and test results obtained.

### Concept

In the diffusion reaction process for forming the compound Nb<sub>3</sub>Sn, tin is diffused into niobium at temperatures between 900° and 1200° C (ref. 6). By means of an inert shielding material, formed in a pattern to outline desired current paths on the niobium surface, the tin can be prevented from directly contacting the niobium in the masked regions. Thus by outlining continuous filamentary paths spiraling around the ribbon, diagonally across the faces and around the edges, Fig. 1, a base is established for reacting the tin and niobium in the twisted, filamentary structure as indicated in Fig. 2. Any nonsuperconductive material which could be bonded to the niobium, was insoluble in tin at the high temperatures, and could be selectively applied or selectively removed, might qualify as a mask material.

### Procedure

Not many materials meet the previously stated shield material requirements. Ceramic materials might, but the application process and adherence present problems. Only a few metals (mostly the refractories) are sufficiently insoluble in molten tin to be considered, but techniques for their application are not available. Fortunately (for this application), niobium oxide meets the requirements and is readily formed. To oxidize the niobium ribbon selectively in the desired configuration, the portion of the ribbon which is later required to react with the tin must be protected from oxidation or the oxide removed from it. Protection of the surfaces was considered to be more readily accomplished.

The following steps and techniques were utilized to process the the prototype conductor.

1. Niobium ribbon 1.27 cm wide by 0.0025 cm thick (1/2 in. x 1 mil) was cleaned, flashed with an evaporatively deposited copper layer and copper plated to a thickness of 0.0006 cm (1/4 mil). Post-plating heat treatment was used to improve the copper-niobium bond, but this step and the evaporative layer may not be necessary.

2. The plated ribbon was spray coated on all surfaces with a commercial photoresist material and force dried.

3. Computer generated grids reproduced on photographic film as shown in Fig. 3 were placed on each side of the ribbon and indexed to match at the ribbon edges. This grid geometry essentially eliminates the edge match problem that would exist for simple diagonal lines, especially with variations in ribbon thickness or with appreciable ribbon curvature. Note that the diagonal lines span slightly less than the ribbon width. The coated ribbon was then exposed to ultraviolet light through the film mask and the photoresist developed to remove the etch resistant material covering the copper in the non-exposed regions (the lines).

The unprotected copper was then etched off using a conventional etchant. Modification of the process by printing the desired pattern on the plated ribbon using an etch-resistant material would eliminate step 2 and most of step 3. Alternatively, an ink mask printed over the photoresist coating would eliminate the film mask.

4. Niobium oxide was formed on the noncopper-covered regions by passing the ribbon through a furnace at 370<sup>o</sup> C in an air atmosphere. The remaining etch-resist and copper-oxide layer were removed in a dilute acid bath leaving only niobium oxide and bare copper on the ribbon surface.

5. The diffusion reaction apparatus is shown in Fig. 4. A prepared ribbon sample is attached to a sliding rod mechanism which allows the ribbon to be lowered into and withdrawn from the furnace containing the molten tin. No attempt was made to optimize the reaction times or temperatures because this has undoubtedly been thoroughly explored in the commercial operations. Plain niobium ribbons and copper-plated niobium ribbons were also reacted for comparison purposes. Contamination of the tin bath by the copper is not considered to be a problem, because 30 percent tin in copper is apparently used in the commercial processing (ref. 6).

#### Results and Discussion

The geometry selected for the filamentary paths consisted of 10 parallel filaments (5 on each side of the ribbon), having a twist pitch of 2.54 cm and with a ratio of superconductor to filament separator width of 3:1. A photograph of the conductor is shown in Fig. 5. The superconductive

cross section for this geometry is equivalent to about one face of a plain ribbon of equal width.

X-ray and electron microprobe analyses were made on some of the ribbon samples. The X-ray analysis showed that Nb<sub>3</sub>Sn was formed in the desired regions and indicated that no residual copper remained. The electron microprobe also showed no trace of copper indicating that the copper was totally displaced by the tin.

Examination using an optical microscope indicated generally good filament separation and filament formation on both faces and edges of the ribbon. Some defects do occur in the mask resulting in interfilament shorting or interruption of a filament. Random defects of this nature involving only a small part of the ribbon at any one location would probably not be of serious consequence especially if the ribbon were copper clad.

The superconductive transition temperature was measured and was found to be greater than 17.95<sup>o</sup> K. Critical current - critical field tests made over a range of magnetic field strengths from 5 to 8 teslas gave the results indicated in Fig. 6. Magnetic field direction was perpendicular to the ribbon face. Results are shown for both the twisted multifilament and the plain Nb<sub>3</sub>Sn ribbons. Critical current values are considerably below those for commercially available ribbons. This result is not considered to be of particular significance because no attempt was made to maximize performance.

The apparent superior performance of the twisted multifilament conductor in comparison with the plain conductor cannot be definitively explained at this time. Short sample I<sub>C</sub> vs H<sub>C</sub> tests of this nature are not expected to demonstrate coil capabilities. Processing of the plain samples was not identical to that used for the multifilament material in that in one case no copper plating was used and in the other a thinner copper plate had been applied without the evaporative layer or the post-plating heat-treatment. Further tests will be necessary to determine the effect of the omissions of these parts of the process. If inclusion of these steps show I<sub>C</sub> - H<sub>C</sub> results as high or higher than the multifilament results one might conclude that the copper plating improves the diffusion reaction process.

All of the techniques used in the fabrication of the twisted multifilament ribbon were adapted from prior art. Extension and modification of these techniques to produce long lengths of such ribbon appear to be straightforward. Solder connections to the ribbon were easily made and cladding with copper should present no difficulty. Finer filaments than were produced and fine filament separator strips should easily be possible. Longer twist pitch lengths and finer filament separators would result in increased superconductor area, but may not be desirable for reasons of stability.

Conclusions

The experimental pieces of twisted, multifilament  $Nb_3Sn$  ribbon conductor which have been produced indicated that the methods and techniques were sound. Various tests made on the finished ribbon showed that (1)  $Nb_3Sn$  had been formed, (2) the critical temperature was greater than  $17.95^\circ K$  and (3)  $I_C-H_C$  characteristics were below commercially attainable values for plain ribbon, but were encouraging for nonoptimized processing parameters.

Fabrication of longer lengths of ribbon of this type should be possible by adapting available technology to the processes required.

References

1. A.R. Kantrowitz and Z.J.J. Stekly, Appl. Phys. Letters 6, 56 (1965).
2. P.F. Chester, Rep. Prog. Phys. 30, Pt. 2 (1967).
3. Proc. 1968 Summer Study on Superconducting Devices and Accelerators, Brookhaven, BNL 50155, Pts. I-III (1968).
4. M.N. Wilson, C.R. Walters, J.D. Lewin, P.F. Smith, and A.H. Spurway, J. Phys. D. - Appl. Phys. 3, 1517 (1970).
5. R. Hancox, Culham Laboratory Report No. CLM-P 121. Also Proc. 10th Int. Conf. on Low Temp. Phys., Moscow (1966).
6. J.P. Denny and R.W. Hardt, "Superconductors and Methods for the Preparation Thereof," U.S. Patent 3,181,936 (May 4, 1964).

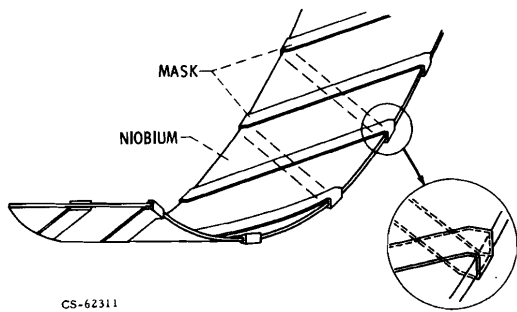

Figure 1. - Mask forming twisted path on Nb ribbon.

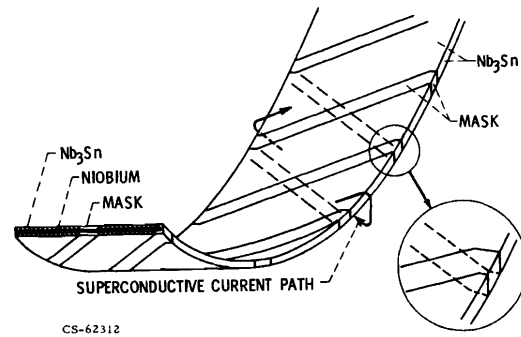

Figure 2. - Twisted filamentary  $Nb_3Sn$  ribbon.

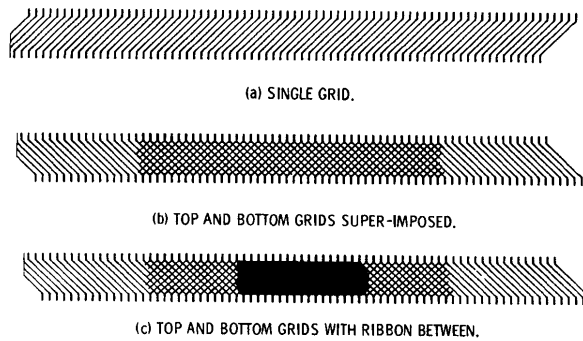

Figure 3. - Photographic film masks used with photoresist process.

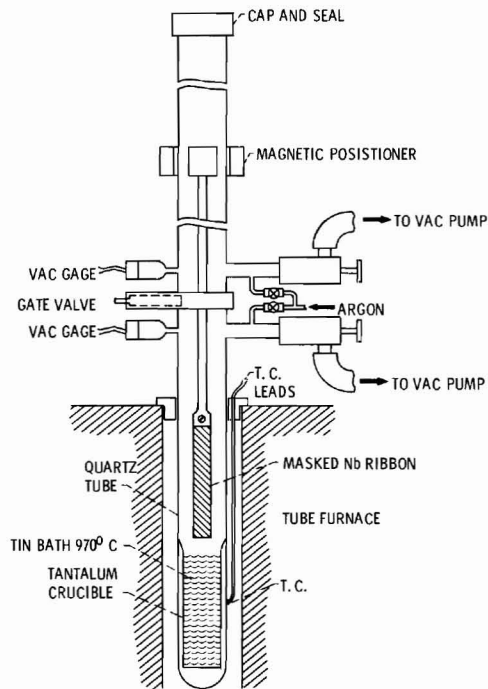

Figure 4. -  $Nb_3Sn$  diffusion reaction apparatus.

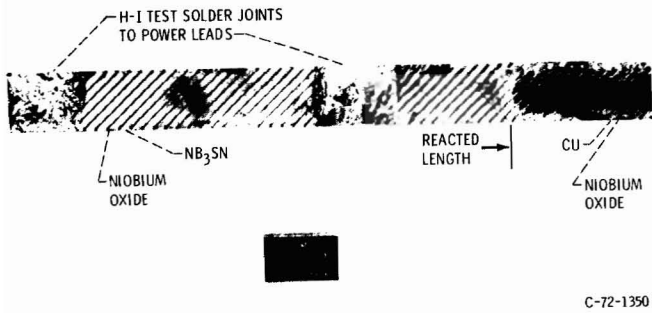

Figure 5. - Twisted, multifilament ribbon.

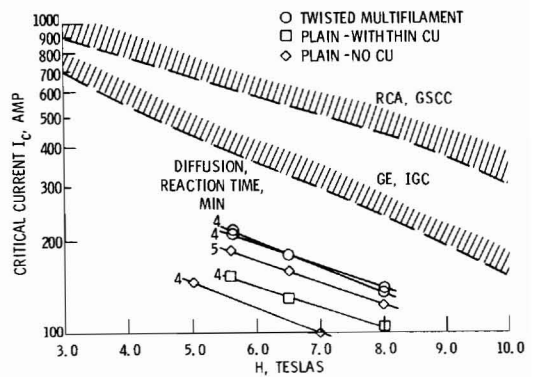

Figure 6. -  $I_c$  vs  $H$  for 1.27 cm wide  $Nb_3Sn$  ribbon.