

## 805-MHZ POWER SOURCES FOR THE LAMPF ACCELERATOR\*

D. C. Hagerman  
University of California, Los Alamos Scientific Laboratory  
Los Alamos, New Mexico

### Introduction

One of the more demanding tasks encountered in the work on the Los Alamos Meson Physics Facility has been the development of a suitable rf power source at 805 MHz. While no major advances in basic knowledge have been gained, many questions about the interaction of high power rf sources and high Q resonant loads have been resolved. Most of the progress has been made on the basis of assiduous attention to detail in measurement, system development, and tube development. For the first time a systematic comparison, under actual operating conditions, of the various rf systems for standing wave accelerator application has been made.

To put this problem in perspective consider the following summary of the system specifications:

Table I

Operating frequency -----	805 MHz
Accelerator peak power demand -	1.0 MW
System design peak power -----	1.25 MW
Permissible phase error -----	$\pm 2^\circ$
Permissible amplitude error ---	$\pm 1.5\%$
Proton beam duty factor -----	6% - 12%
Pulse length -----	500 $\mu$ sec - 1000 $\mu$ sec
Load -----	High Q resonant tank
Load VSWR -----	$\infty$ at start of pulse 1.5 (zero beam) < 1.1 (full beam)

In addition to meeting these requirements the system must operate reliably and economically; the total number of these systems for the accelerator is 44.

The exploratory and preliminary design work for a meson factory based on a proton linac was done by George Wheeler and collaborators at Yale<sup>1</sup> closely followed by work at LASL.<sup>2</sup> The conclusion at that time was that even though a frequency of 800 MHz was high for a triode, it should work. This was based on available proton linac experience with triodes at lower frequencies, scaling of power densities from tubes of proven capability, and consideration of the control problem. There was also some consideration of probable tube lifetime;<sup>1,3,4</sup> however, this area was and is a muddy one.

The first experimental work was based on a joint procurement of triodes by the Yale group and LASL. Initially, progress was slow since funds were quite limited and because production of a new tube has a long lead time. However, in 1965,<sup>5</sup> we were starting to produce peak powers at interesting levels and coming to grips with the average power and the control problem.<sup>6</sup>

\*Work performed under the auspices of the U. S. Atomic Energy Commission.

Since that time LASL has experimentally explored the problems of using triodes, crossed-field amplifiers (CFA), and klystrons in linear accelerator service. Our conclusion has been that the klystron is the current tube of choice; however, the CFA continues to have tantalizing possibilities.

### Test Program

Although our first evaluation of this problem indicated that the triode should be the optimum choice, both klystrons and CFAs were discussed and one could easily find spirited proponents of each approach. Unfortunately, no directly applicable experience was available nor was there any apparent way in which the system choice could be made on the basis of application of fundamental principles. Our only recourse was to build and test complete systems so that we might have sound experience on which to base our judgment. This procedure forces one to meet first hand not only the difficulties inherent in the tubes, but in the total system.

In all cases the tubes were procured from representative electron tube manufacturers\*\* and the system design and construction was done at LASL. This procedure was occasionally unwieldy-- particularly when we wished to see some specific change in tube designs. Other laboratories in this situation frequently have set up their own tube shops which were used for tube development and occasionally for tube production. We wish to minimize the amount of component manufacturing at LASL (especially on items which will be in continuing production), and thus have elected to avoid the "in-house" tube shop. We believe that in our circumstances this procedure was the least expensive method of obtaining developmental tubes.

The detailed aspects of the test program have been reported in our progress reports and in previous publications<sup>7,8,9,10</sup> and will not be repeated here. The following table gives a comparative summary of our results.

Table 2

	<u>Klystron</u>	<u>CFA</u>	<u>Triode</u>
Resonant load operation	OK	No	OK
Noise Output	OK	No	OK
Operation at 6% DF	Yes	Yes	100 h max.
Tube efficiency (%)	40-45%	60-70%	35-40%
System efficiency (%)	38%	53%	30%
Relative system cost	median	lowest	highest
Handling problems	Yes	No	No
Operating voltage (kV)	80-90	50-60	35-40
System complexity	least		Similar

\*\*The integral cavity triodes (Coaxitrons) were obtained from RCA, the CFAs (Amplitrons) from Raytheon, and the klystrons from Litton.

In brief, the klystron was our final choice on the basis of available tubes since it was the only tube which performed satisfactorily for this service. The triodes (Coaxitrons) were abandoned because they would not perform at the desired average power levels with appreciable lifetimes. The crossed-field amplifiers were dropped because of serious noise problems.

The crossed-field amplifier, in spite of the noise problem, remains a tempting rf source due to its high intrinsic efficiency and simplicity of construction. The high efficiency reduces the power costs. The simple construction should be easy to optimize for very long tube life. These virtues are so appealing that we are keeping our CFA test stand intact for another few months so that we may evaluate a single stage Amplitron currently being constructed by Raytheon for us. Also, it appears that by proper choice of the IVR range on our high-voltage power supplies it should be relatively easy to convert a klystron system to a CFA system should this be desirable at some time in the future. We intend to make this provision in the power supplies for the accelerator.

#### Cost Studies

Although our test results led us to the klystron system and ruled out triodes and CFAs, we did make comparative cost studies of all three systems. These studies were based on the assumption that all system development and design will be done at LASL and tube development and production will be done by qualified vendors. Further, with the exception of well developed components such as large power supplies, all system components will be constructed on the basis of our design plans rather than performance specifications.

One of the difficulties with these cost studies is our rapidly escalating economy. Thus, cost figures more than a few months old are usually incorrect. Another difficulty lies in the budgetary estimates provided by manufacturers. While these estimates are prepared with good intentions, the discrepancy between budgetary quotes and firm bid prices is often so large as to make a major perturbation in any comparative costing study. Fortunately, we have now purchased enough components for our R&D program so that most of the confusion resulting from budgetary quotes has been removed.

Due to the rapid escalation of prices, a cost breakdown is not included in this article. Relatively, the triode system would cost the most to install, the klystron system is intermediate in price, and the CFA is the least expensive. Cost differences between the systems are not large-- typically 10-20%. Certainly there is no basis for a substantial development of the CFA system on the argument that its construction cost would be substantially lower than the other systems.

A major cost difference between the klystron system and the CFA system is in the cost of power supplies. The klystron requires a 50% larger average power at about 50% higher voltage than does the CFA. The increased voltage plays a stronger

role in cost than the average power change since in this range the relative transformer cost depends much more strongly (~ a factor of 10) on voltage rating than on kVA rating. We are going to exploit this fact by using the same power supply for several tubes. The effect of this joint usage is shown in Fig. 1 which clearly demonstrates the economic advantage of this scheme.

#### Present Study Program

##### Tube Parameter Studies

At this time two of the 1.25-MW peak power Litton klystrons are in operating condition. The first tube has been run at LASL for ~ 650 h of beam time. Most of this operation has been at 500- $\mu$ sec pulse length and 6% DF. It is shown installed in its modulator in Fig. 2. The second tube has not been run at LASL, but is being held in reserve; some testing at the Litton plant established its general characteristics and verified that it would run at least a few hours at 12% DF, 1.25-MW peak power output. The purpose of most of the testing thus far has been to verify that such a klystron is suitable for powering a proton linac. We have now started to make more detailed studies which will permit us to exploit these tubes to the fullest in this service.

The first tube was recently run at higher voltages and reduced current from the design values. This was done by varying the potential of the modulating anode which effectively varies the perveance of the tube. The general effect was that as the beam current (or perveance) of the tube was reduced, the efficiency and stability of the klystron improved. For example, at ~ 1-MW output the tube could be run at 39 A of beam current with an efficiency of 37% or at 29 A and 42% efficiency. Studies such as this will continue.

We have started the construction of three additional test stands to be used for tube life studies. We believe that it will be quite profitable to have run some tubes to failure before the initial set of tubes for the accelerator is procured; this way at least some of the defects in tube design may be corrected at a relatively early time. We are procuring five tubes from Varian and five from Litton for this exercise with the first tube deliveries expected in the fall of 1968. The test stands should be ready for use early in 1969.

##### Operation of the Electron Prototype Accelerator

The existing LASL electron prototype accelerator<sup>11</sup> provides us with a test vehicle which exhibits, as far as the rf system is concerned, many of the problems which will exist on the proton linac. Although the beam dynamics in this machine are different in many respects from that of the proton machine, the beam loading effects are quite similar. Thus, we are able to study this effect experimentally long before the real accelerator will be in operation. This permits us to optimize control system performance under realistic operating conditions.

The experiments performed thus far<sup>12</sup> have not given us any unpleasant surprises. The number of signals which must be measured simultaneously with reasonable precision is impressive. For example, in measurements made in early May some 15 analog signal channels were recorded simultaneously. To handle this quantity of information we have made use of the computer being used for control computer studies; this has been quite interesting and instructive. We are convinced, based on this experience, that this method of control and data accumulation is profitable and proper for the study of complex systems.

### System Design Studies

It is evident from the construction schedule that essentially final design must be complete early in 1969. Thus, we are spending a substantial amount of effort in improving our test stand design to a degree suitable for production of the 44 amplifiers needed for the machine.

An example of this effort is displayed in Figs. 3 and 4 which show the circuits of two possible klystron modulators.<sup>13</sup> The function of either of these circuits is to switch the potential of the klystron's mod-anode from cathode potential to or near body potential which turns the klystron beam on. The active high-voltage element--a tetrode--is the same in either circuit; the difference is in the method of transmitting information from ground level to the grid of the tetrode.

The operation of the circuit in Fig. 3 is straightforward; a large pulse transformer is driven from ground level and its output drives the grid of the tetrode directly. In the other circuit (Fig. 4) an interface transformer is again used to switch the tetrode on, but once the tetrode is turned on it remains on due to the regeneration introduced by the transformer in the cathode circuit. The tetrode remains on until either an "off" signal comes from the interface transformer or the cathode transformer saturates. Although the second circuit is somewhat more complex it has the advantage that the interface transformer is much smaller (10 lbs vs 200 lbs) and is substantially cheaper to fabricate. The cathode transformer in the second circuit is simply a standard audio transformer of suitable ratings. The first circuit has been used for some time and the second is currently under evaluation in our test stand.

Another example of system development is found in our method of moving tube and modulator assemblies. Replacement tubes for the accelerator will be assembled into their modulators and given a test run before they are placed into machine service. Tubes will then be transported to one of the rf cluster buildings along the accelerator and stored until needed.

Once the tube and modulator is at the cluster building, it will probably be moved by an arrangement of air lift pads as shown in Fig. 5. This scheme has been tried on a full size and weight mockup. Initially the system oscillated rather wildly, but this was cured by appropriate pneumatic feedback in the air system supplying the lift

pads. This scheme will now be evaluated on actual tube and modulator assemblies. It has the advantage of reduced cost over any scheme involving cranes.

A possible amplifier layout within one of the cluster buildings is shown in Fig. 6. The control racks contain rf equipment, the computer interface equipment, accelerator focusing magnet power supplies, etc. Each cluster building will have ample storage space for pre-tested components and test equipment so that in the event of trouble an rf system may be quickly repaired.

### Acknowledgments

The test and evaluation of rf power sources for the LAMPF accelerator has been carried on by a substantial number of persons. Each of these has contributed to this program and I sincerely appreciate their efforts.

### References

1. Yale Study on High Intensity Proton Accelerators Internal Report Y-12, "A Final Report on the Design of a Very High Intensity Proton Linear Accelerator as a Meson Factory at an Energy of 750 MeV," Oct. 1964, pp. III-85 to III-102.
2. "A Proposal for a High-Flux Meson Facility," Los Alamos Scientific Laboratory, Sept. 1964, pp. 358-363.
3. M. V. Hoover, "Grid Controlled Power Tubes in Particle Accelerator Applications," *IEEE Transactions on Nuclear Science*, June 1965, Vol. NS-12, No. 3, p. 76.
4. A. J. Morris and C. A. Martin-Vegue, "A Comparison of Triodes and Klystrons for Particle Accelerator Applications," *IEEE Transactions on Nuclear Science*, June 1965, Vol. NS-12, No. 3, p. 96.
5. D. C. Hagerman, J. D. Doss, R. W. Freyman, and J. R. Parker, "An 805-Mc 1-1/4 MW Amplifier for Accelerator Service," *IEEE Transactions on Nuclear Science*, June 1965, Vol. NS-12, No. 3, p. 96.
6. R. A. Jameson, T. F. Turner, and N. A. Lindsay, "Design of the RF Phase and Amplitude Control System for a Proton Linear Accelerator," *IEEE Transactions on Nuclear Science*, June 1965, Vol. NS-12, No. 3, p. 138.
7. Los Alamos Scientific Laboratory, "Quarterly Status Reports on the Medium-Energy Physics Program," LA-3521-MS, LA-3587-MS, LA-3624-MS, LA-3673-MS, LA-3712-MS, LA-3772-MS, LA-3828-MS, and LA-3884-MS.
8. D. C. Hagerman, "High Duty Factor RF Sources at 800 MHz," *IEEE Transactions on Nuclear Science*, June 1967, Vol. NS-14, No. 3, p. 197.
9. R. A. Jameson and W. J. Hoffert, "Fast Automatic Phase and Amplitude Control of High-Power RF Systems," *IEEE Transactions on Nuclear Science*, June 1967, Vol. NS-14, No. 3, p. 205.

10. T. J. Boyd and R. A. Jameson, "Optimum Generator Characteristics of RF Amplifiers for Heavily Beam-Loaded Accelerators," IEEE Transactions on Nuclear Science, June 1967, Vol. NS-14, No. 3, p. 213.
11. E. A. Knapp and W. J. Schlaer, "Design and Initial Performance of a 20-MeV High-Current Side-Coupled Cavity Electron Accelerator," Proceedings of the 1968 Linear Accelerator Conference, p.635
12. R. A. Jameson, "Automatic Control of RF Amplifier Systems," Proceedings of the 1968 Linear Accelerator Conference, p.149
13. J. D. Doss, R. L. Cady, D. C. Hagerman, and T. F. Turner, "80-Kilovolt Blocking Oscillator Modulator," Proceedings for 10th Modulator Symposium, May 21-22, 1968.

#### DISCUSSION

(D. Hagerman)

WHEELER, BNL: How many cavities are in that klystron and what is its gain?

HAGERMAN, LASL: A klystron with four cavities was unsatisfactory. Both of our vendors seem happy with a five cavity klystron. The nominal gain is 50 dB (design figure 47 dB).

FEATHERSTONE, CERN: Would you have a spare modulator complete with a tested tube in your "cluster building" ready to substitute for a unit which has failed? If so, how long would it take to make this replacement?

HAGERMAN, LASL: That's correct. It should take only about an hour, otherwise there is no point in keeping the spare klystron so close by.

WARD, AECL: I notice you put the cost figure lowest for the CFA. Could you give us the relative cost of components, so we can see where the cost advantage came from.

HAGERMAN, LASL: Primarily, the cost advantage comes from the power supplies. Using the "old system" figures, the conversion efficiency of the CFA is 58% compared to 38% for the klystron. In addition to this factor of 1.5, the power supply costs are substantially lower because the very high voltages necessary for klystrons are not required. On the other hand the CFA requires a more sophisticated modulator.

WARD, AECL: I'm surprised that the cost of the CFA plus its driver is not higher than that of the klystron.

HAGERMAN, LASL: In our scheme, the driver klystron uses the same supplies as the CFA. What one really adds to the CFA system are relatively inexpensive magnet power supplies and the driver klystron. The cost difference is in the order of 20%. This is not so large, that we want to go ahead full speed to develop the CFA.

FEATHERSTONE, CERN: Probably one of the critical problems in the CFA is the need for isolators rated for your peak and average power levels. Were these included in your cost estimates and are they available?

HAGERMAN, LASL: Yes. The cost is estimated at 4 to 5 thousand dollars for a 3 dB isolator for a full height waveguide. A 20 dB isolator in "one third height waveguide" size would cost roughly the same. The total isolator cost per system (you need them at both ends) is less than 10 thousand dollars. I think these figures are reasonable and the costs may be reduced. Isolators are not as difficult to build as some people would have you believe.

BRAMHAM, CERN: Do you expect changes in klystron H.T. voltage to introduce phase shift troubles in the klystron. The final voltage seems to be very low.

HAGERMAN, LASL: A 1% change in supply voltage results in an 11 degree phase shift. Our capacitor banks will be designed to have a 5% drop during the pulse. The resultant 50° of phase shift can be corrected at low rf level. We are planning to allow for 100° of fast phase shift. Initially we considered connecting the main capacitor between the cathode and collector and using a smaller capacitor to maintain a constant potential between the cathode and body, but this complicates the crowbar.

NEAL, SLAC: I understand you are planning to introduce two types of tubes. Would you comment on the operational advisability of doing this and what later problem will arise when and if you go back to one type?

HAGERMAN, LASL: If we do this, it will be in the final cluster building. The lifetime of these devices is unknown to us. A statistically significant sample of each type is required in order that we can determine the operating cost, which is probably the most important factor when it comes to running an accelerator. Having two systems will certainly be a nuisance, because the engineering will have to be done twice. Before we do this we must be sure that the CFA is a running device and in view of our schedule this must be ascertained within the next few months.

TUNNICLIFFE, AECL: Are you going to build features into the system to give you some finite chance of keeping all 44 units on the air at the time?

HAGERMAN, LASL: We think the only way to handle this problem is to make the system as simple as possible; minimize the number of components; and to overrate all components. We are designing our system for 1-1/4 MW and the peak demand for the accelerator is 1 MW. Any component which has a reasonable probability of failure can be replaced in short time. For instance, all of our small power supplies are being standardized to the extent that the connectors are in the same place and the units are easily replaceable. Later you will

hear of some of the schemes for rapid trouble shooting of an amplifier.

LEISS, NBS: Can anybody tell me how to derate components in order to get high reliability?

HAGERMAN, LASL: If you find out, I'd like to hear about it.

UNIT HVPS COST VERSUS MODULES PER HVPS

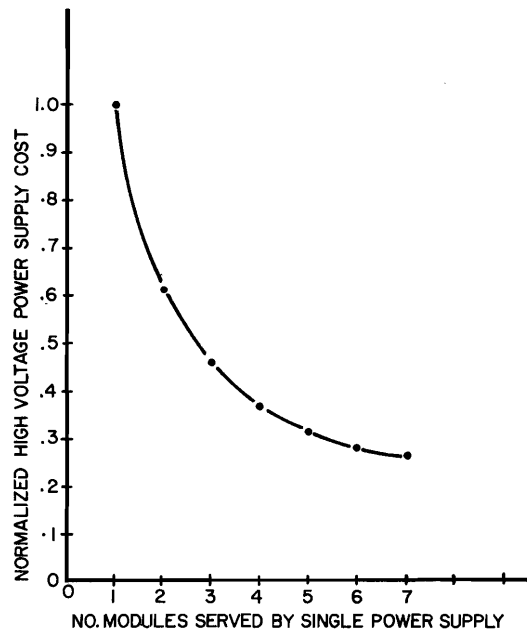

Figure 1 — Unit HVPS cost versus modules per HVPS.



Figure 2 — The first Litton klystron received at IASL mounted in its magnet. The modulator is contained in the rectangular oil tank resting on the floor.

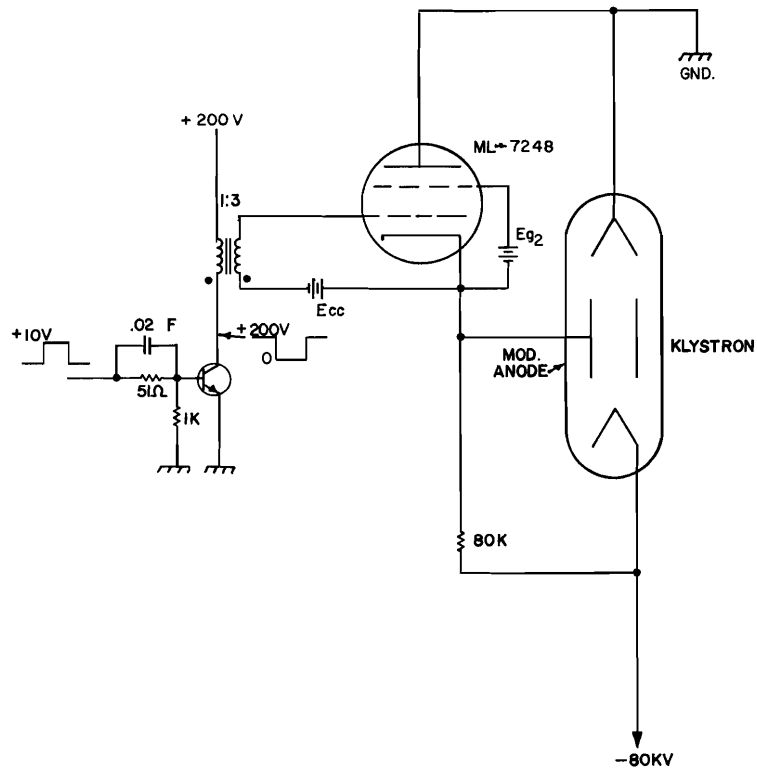

Figure 3 — A schematic of a klystron modulator using direct transformer coupling. The coupling transformer must be large enough to provide a high-quality 1-msec pulse.



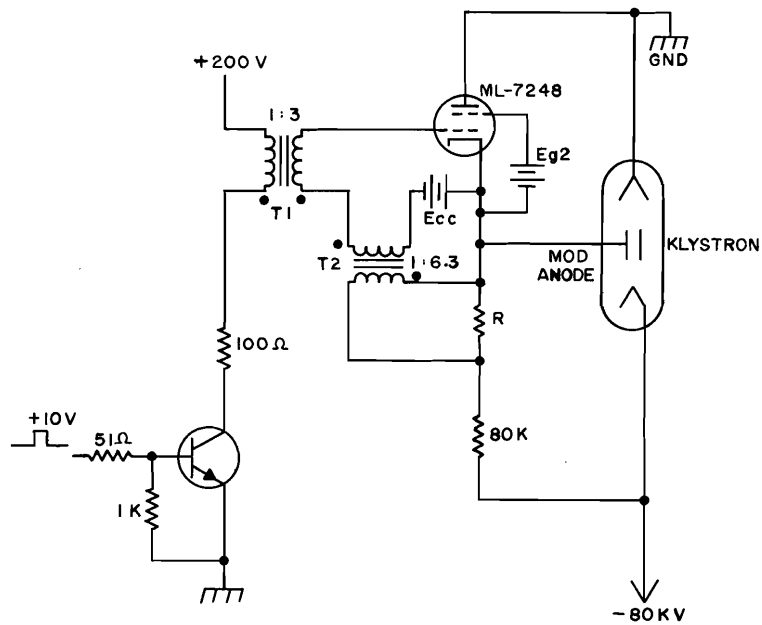

Figure 4 — Klystron modulator using regenerative feedback. The high-voltage coupling transformer ( $T_1$ ) need only be large enough to provide a 20- $\mu$ sec pulse to turn the circuit on and off, whereas the low-voltage feedback transformer ( $T_2$ ) provides the long-pulse capability.

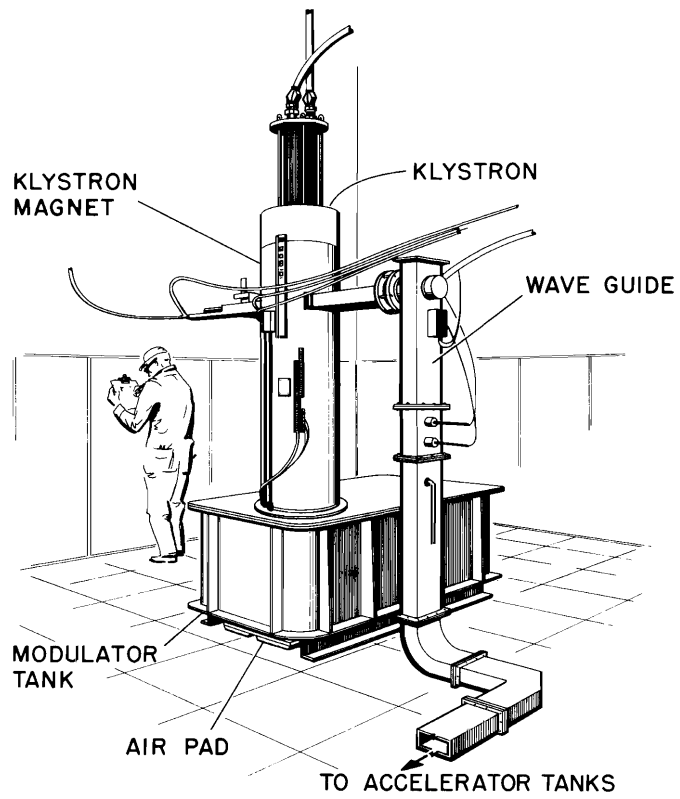
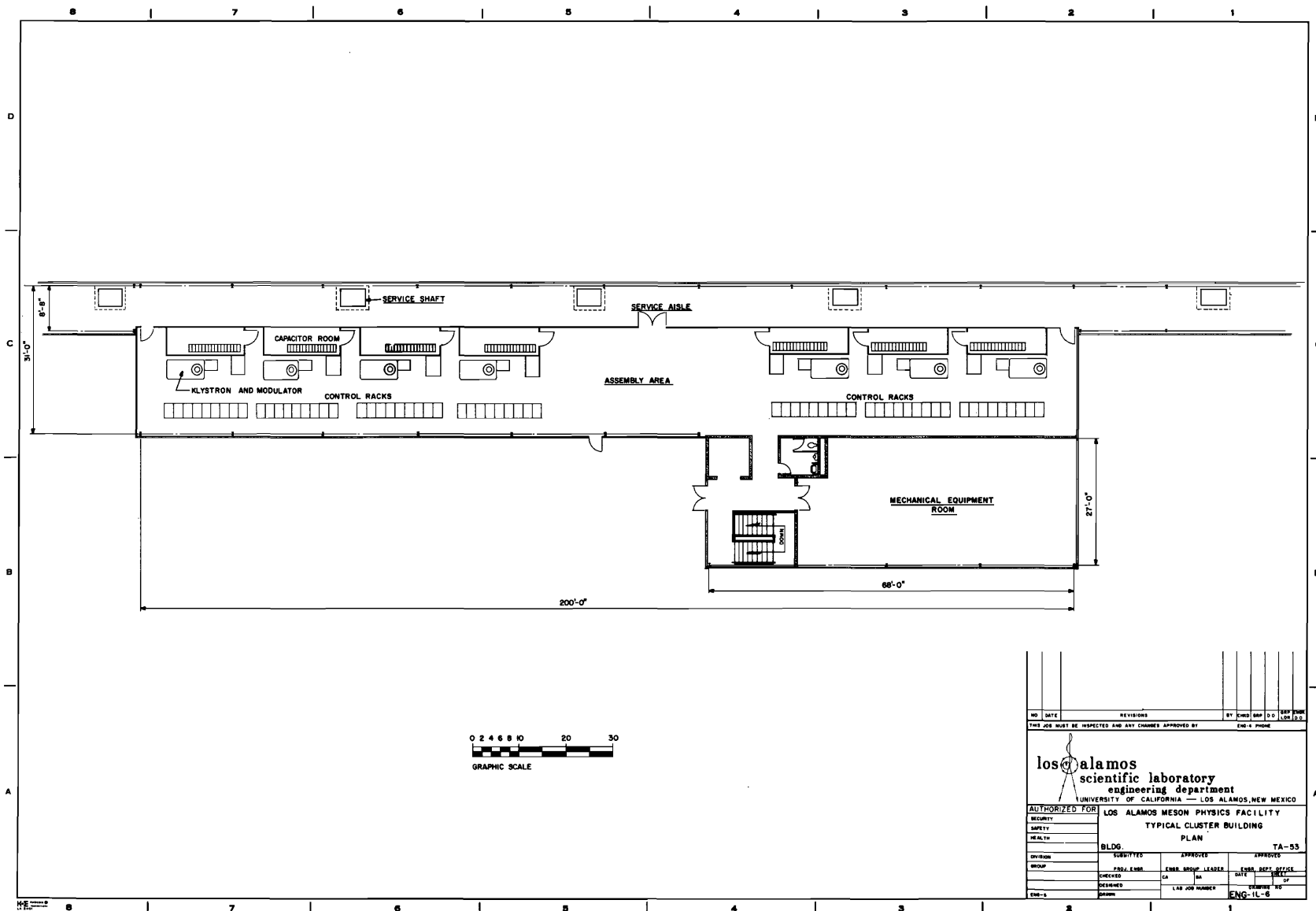

Figure 5 — 1.25 MW klystron power amplifier.



<b>los alamos</b> scientific laboratory engineering department UNIVERSITY OF CALIFORNIA — LOS ALAMOS, NEW MEXICO	
AUTHORIZED FOR: LOS ALAMOS MESON PHYSICS FACILITY TYPICAL CLUSTER BUILDING PLAN TA-53	
SECURITY SAFETY HEALTH DIVISION GROUP	BLDG. IDENTIFIED PROJ. ENGR. CHECKED DESIGNED DRAWN
SUBMITTED CA DATE	APPROVED ENGR. GROUP LEADER SA DATE
ENR-6	ENR-6 LAD JOB NUMBER ENR-1L-6

Figure 6 — Typical cluster building.