

R.F. SOURCES DEVELOPMENT AT C.R.N.L.

P.J. Waterton,
Atomic Energy of Canada Limited,
Chalk River, Ontario, Canada.

The rf power requirements for the ING linac are:

80.5 MW at 805 MHz
10 MW at 268 $\frac{1}{2}$ MHz

Our present concept of the rf sources of this power is:

161 0.5 MW units at 805 MHz
8 1.2 MW units at 268 $\frac{1}{2}$ MHz
1 0.4 MW unit at 268 $\frac{1}{2}$ MHz

In order to fulfil the economic requirements for the neutron generator as a whole the units must be large, efficient, reliable and long lived.

Units as large as feasible are necessary to minimise the installed cost per kilowatt, as this decreases with increasing unit size. This is important because the total rf sources costs will be \$20-40M. However, the adoption of large units must not prejudice attainment of the other aims.

If our ac to rf conversion is the hoped-for 80% our annual power bill, with ac at 5 mills/kWh, would be about \$4M. Lower efficiency will not only increase operating costs but also initial costs of the power supplies and cooling systems.

We plan to operate ING continuously for 20 day periods, with 5 day shutdown intervals for routine maintenance and changes to experimental arrangements and target loading. Table 1 indicates that we will need a Mean Time Before Failure of 10⁵ h per unit if there is to be a good probability of all units operating for this time.

TABLE 1

<u>MTBF</u>	<u>500 h</u> <u>RELIABILITY</u>
10 ⁶ h	.923
10 ⁵ h	.449
10 ⁴ h	3.3 x 10 ⁻⁴
10 ³ h	1.8 x 10 ^{-3.5}

Fortunately we expect to be able to design the machine so that operation may be possible without one of the 805 MHz generators, and it may only be necessary

to achieve a high probability of repairing it before another failure. A large increase of unit size may prejudice this facility.

As there will be \$3-5M worth of power tubes in the system they must be long lived to minimise replacement costs, as well as to satisfy the criteria for reliability.

Our current study concentrates on two of these four requirements, those for size and efficiency only. The first objectives are to satisfy ourselves that the unit sizes are feasible and that there are good prospects of achieving high efficiency and reliability after a period of development. Because the units are amplifiers whose performance is determined by the tube in the final power stage, the program is naturally dominated initially by studies of suitable tubes.

100 kW Amplitron

A year ago we acquired from Raytheon a 100 kW test set on which two QKS 1461 amplitrons have been tested and developed on an exchange basis. The major problem has been the production of power at frequencies unrelated to the drive frequency. Some results of our earliest tests are shown in table 2.

TABLE 2

<u>f</u> <u>(MHz)</u>	<u>P_o</u> <u>(kW)</u>	<u>η</u> <u>(%)</u>	<u>1130 MHz</u> <u>(dB)</u>
770	76	52	-14
775	80	60	-30 to -40
778	76	55	"
800	75	55	"
805	50	50	"

Efficiencies about 50-60%, and power outputs up to 80 kW were obtained at an acceptable level of spurious power, but any attempt to increase the output or efficiency resulted in a disproportionately large increase of the 1130 MHz output. The best performance was not at the design frequency of 805 MHz. Figure 1 shows the spectrum of a recent test of a tube

modified to increase the frequency of the spurious mode (to 1460 MHz) and hence reduce its coupling to the electrons. The second harmonic seen here is also present in the output of the driver klystron. The power output is 95 kW at the design frequency, the efficiency 65%, and the gain 9 dB. The incremental gain is only about 2-3 dB and lack of drive power limits the present performance, but we expect improved efficiency from this tube when it is tested with a higher magnetic field.

500 kW Amplitron

We are also acquiring from Raytheon a 500 kW Amplitron, the QKS 1494, similar to the Los Alamos 1.25 MW pulse tubes. Completion has been delayed to take advantage of the design information available from the 100 kW tests. We hope to start power runs in July or August.

Slow-Wave Structures

The interpretation of experimental measurements on crossed field amplifiers in terms of structure modes and their interactions with the electrons is not simple. We are studying the properties of slow-wave structures by cold test measurements and plan also to build hot test models to improve our understanding. Figure 2 shows the interpretation given to the results of some measurements by Prof. R.G. Bosisio of Ecole Polytechnique, in Montreal, on an amplitron-like structure. The strength of the space harmonics is indicated by the thickness of the line and a narrow stop-band is seen interrupting the dominant modes at $\beta L = 2\pi$. An electron velocity line intersects the dominant mode at the desired frequency and also a space harmonic of the upper pass band at a spurious oscillation frequency.

The more usual dispersion curve is shown in figure 3 together with a 'ghost' curve shifted in phase by $\beta p = \pi$ ($L =$ cell length $= 2p = 2$ anode bar pitches), making it analogous with figure 2. The ghost may be explained by the asymmetrical termination of the balanced two-wire structure by an unbalanced coaxial feed.

100 kW Klystron

Continued improvement in klystron efficiency makes the klystron an attrac-

tive possibility for the 500 kW 805 MHz units. We have purchased an Eimac VA-853M five-cavity television amplifier klystron, M meaning modified from the stock 75 kW, 43% efficiency, to 100 kW, 54%. We are preparing it for tests as a driver for the 500 kW Amplitron and perhaps for accelerator cavity trials.

1.2 MW Triode

We have chosen to develop a Super-Power Triode amplifier for the Alvarez linac test source, although a crossed field amplifier is our reference design. We will try to get 1.5 MW on test, at least twice as much power from one tube as ever before, from an RCA A-15039, which will perhaps satisfy our size, reliability, and life requirements. An efficiency of 50 to 60% is expected, perhaps sufficient for this small part of the accelerator, though if the lower figure applies the output may be limited to little more than the necessary 1.2 MW.

The grounded-grid triode will be used in a cavity of our own design and construction, figure 4, based on R.C.A.'s tube-test amplifier. Both input and output cavities are $3 \lambda/2$ long with the tube in the centre, tuned by spring-contact plungers at each end. The current densities here and at the fixed spring-contact connections to the tube are high, and we are ignorant of their proper rating. Should they prove unreliable we shall make a clamped connection to the tube and modify the tuning plungers to a bucket shape to bring the contacts away from the current maximum. Subsequent versions of the amplifier may be able to dispense with major tuning facilities entirely.

Voltage breakdown problems are less severe than with pulsed operation, so the anode blocking capacitor is less difficult to design. At its free end (A, fig. 4) it has to withstand 20 kV dc to the outer, and 20 kV dc plus 28 kV peak rf to the inner, of the coaxial cavity. The thick bead, not circular but empirically shaped using a conducting paper analogue, limits the stress to 32 kV/in., permitting operation at atmospheric pressure with a safety factor of 3.

The resonators were designed by applying transmission line equations to the interior of the tube as well as to

the exterior cavity. No correction was made for discontinuity capacities, but cold tests with uniform external lines confirmed the calculation within 1%. On cold testing the completed amplifier in May we found that we had missed our frequency by 5%, mainly because the discontinuity at the free end (A, fig. 4) of the anode blocker is not negligible, being deliberately sited at the low current, and hence high voltage, position. The blocker is being cut back to restore the tuning plunger's position (which has a major effect on output coupling) and incidentally to bring its length closer to a desirable $\lambda/2$.

When the amplifier has been developed to an acceptable performance in other respects we shall consider trying to increase its efficiency, as an alternative to developing a crossed-field amplifier for so few units. By the use of anode cavities resonant at the third harmonic as well as at the fundamental a version of the Tyler¹ circuit can be tried. Figure 5 shows how the addition of 15% of third harmonic enables the fundamental component of anode voltage to be increased by 18% without altering the instantaneous voltage during the maximum of the current pulse at $\omega t = \pi$. This would raise efficiency from (say) 55 to 65%, while further improvement to 70% can be anticipated by similar modifications to the current pulse waveform.

We expect a gain of 13 dB, and shall use the RCA A-2548 tetrode to provide the requisite 75 kW of drive power. We in fact expect 100 kW from the driver, which is being developed for us by Prof. F. Konopasek of the University of Manitoba, Winnipeg, from the master oscillator upwards. An output of 25 kW at 65% efficiency, limited by the available power supply, has already been demonstrated, and installation at CRNL is now under way in preparation for a full power test by the end of June. The design of circuits for this tube, which has the grid and anode seals on opposite ends, closely follows that of a television amplifier published by RCA² in 1955. The problems involved are very similar to those of the triode.

D.C. Power Supplies

Our several potent rf sources need potent dc supplies. Assuming that a con-

siderable diversity may apply to the loads, we are providing a universal power source, consisting of four similar modules controlled by induction regulators, and one smaller fixed-voltage supply. By a combination of dc interconnection, transformer secondary taps, and Y- Δ switching we can provide any voltage from 6 to 60 kV, either side grounded, with a full power of 2.4 MW available at 60, 40 or 20 kV. At lower power demands two or three loads can sometimes be supplied independently, for example the triode, the tetrode and the 100 kW klystron, if for the occasion the triode is limited to 1.6 MW input.

We do not have as much energy storage in these supplies as in those for a long-pulse amplifier but neither do we have series modulator tubes which could interrupt a fault. The short-circuit current available until the circuit breakers open may reach 880 A, limited by series inductors added to the transformer primaries. In spite of this we hope to crowbar satisfactorily by being 1 μ s quick on the trigger, aided by large inductors on the dc side (.6 mH for a 20 kV 40 A module) to limit the rate of rise of current. We have developed a criterion for predicting the performance of a crowbar, and expect soon to prove it on test.

Acknowledgements

The R.F. sources development programs mentioned above are undertaken at the Chalk River Nuclear Laboratories of Atomic Energy of Canada Limited under the leadership of P.R. Tunncliffe. Individual responsibilities are

Amplitron experimental program-J.C. Brown
C.F.A. structures investigation-C.B. Bigham
100 kW klystron tests -R.E. Green
Triode amplifier & dc supplies-
P.J. Waterton

References

1. A new high-efficiency high-power amplifier. V.J. Tyler, The Marconi Review, 21, 96-109, 1958.
2. A novel ultra-high-frequency high-power-amplifier system. L.L. Koros, RCA Review 16, 251-280, 1955.

DISCUSSION

(P. J. Waterton)

HAGERMAN, LASL: Will the 500 kW ampliftron have one or two stages?

WATERTON, AECL: It will be a two stage device very similar to the LASL ampliftron; I am not sure whether there are any significant differences.

JAMESON, LASL: You mentioned that you can run your accelerator with one amplifier missing. Would you expand on that please?

WATERTON, AECL: Yes. This is a question of beam dynamics. If one amplifier is missing, two tanks go out of service. If this happens at above 200 MeV, it is possible to keep the accelerator running by changing the phase and amplitude either locally or in a distributed manner among all the other tanks. If it happens at an energy less than 200 MeV, it is fairly certain the accelerator would go off the air. There is also the possibility of running some sort of manifold system for the rf which we haven't yet considered in detail.

SWENSON, LASL: Our own studies indicate we would not expect to be able to operate if one rf system failed. I think this is quite understandable because the energy gain per amplifier in the Los Alamos structure is quite different from yours. What is the average energy gain per amplifier?

WATERTON, AECL: You have 44 amplifiers and we have nearly four times as many, so LASL has four times the energy gain per amplifier as AECL. The quantitative answer is 5.6 MeV.

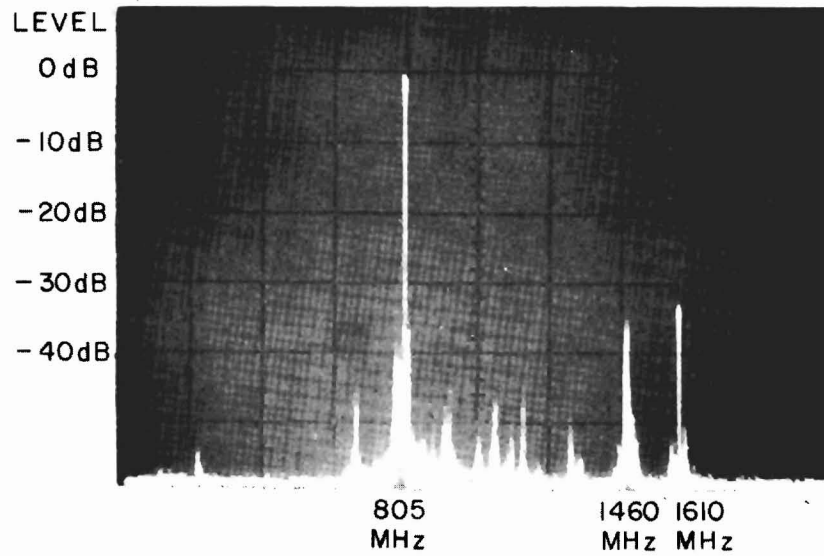

FIGURE 1: Spectrum of Recent Amplitron Test

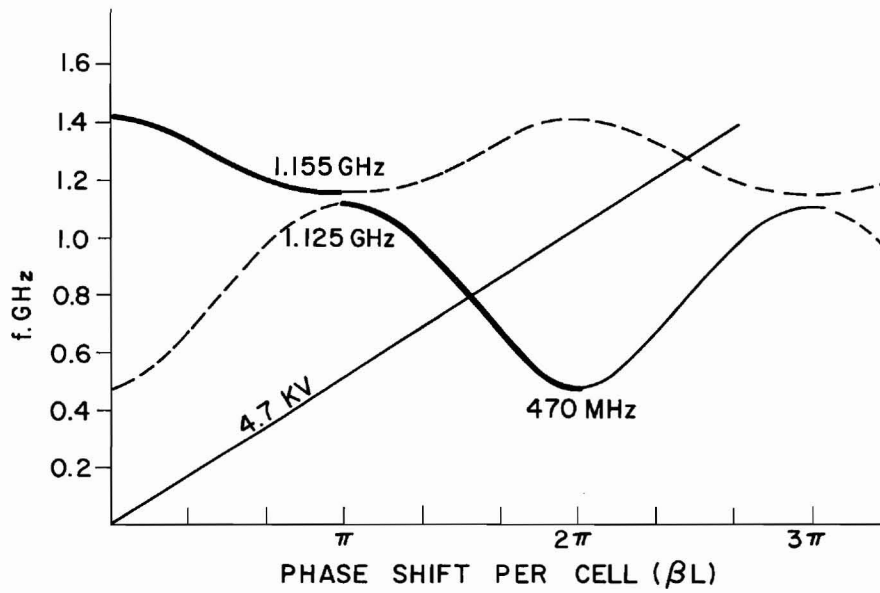

FIGURE 2: Dispersion Curve of Amplitron-Like Structure

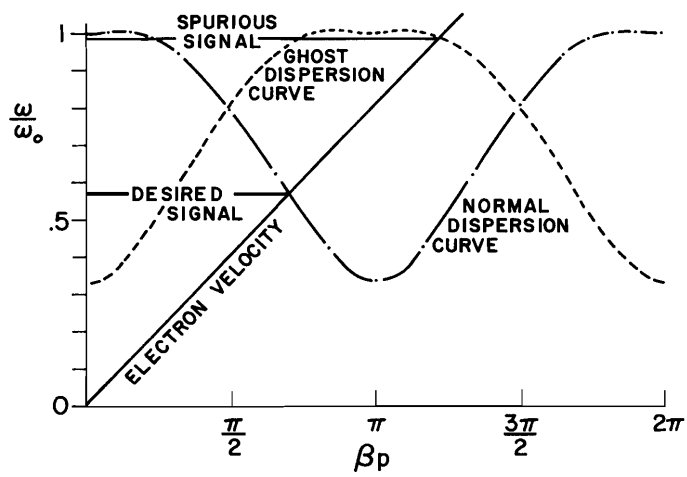

FIGURE 3: Dispersion Curve of Typical Amplitron Structure

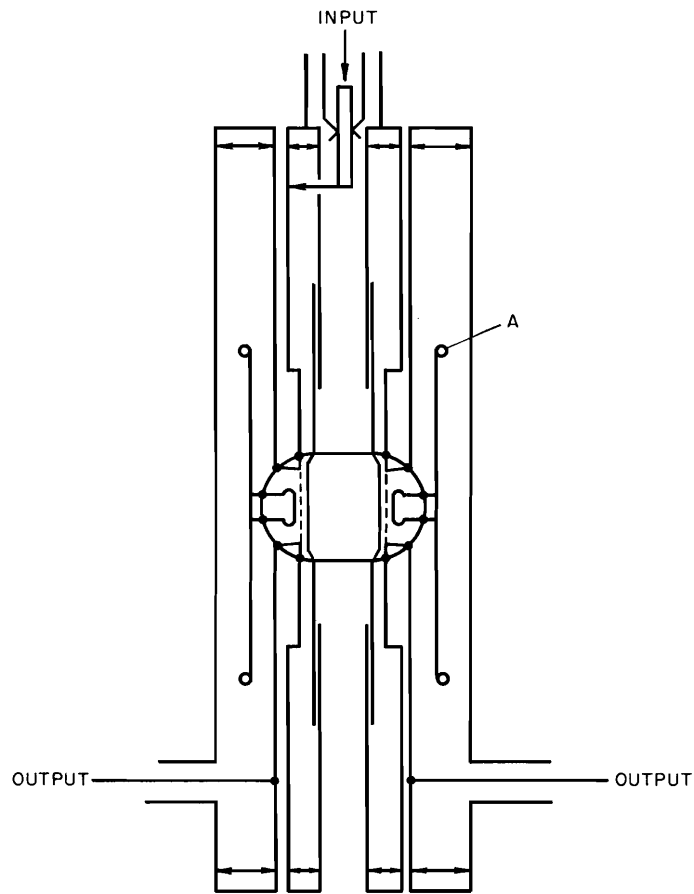

FIGURE 4: Diagram of Triode Amplifier

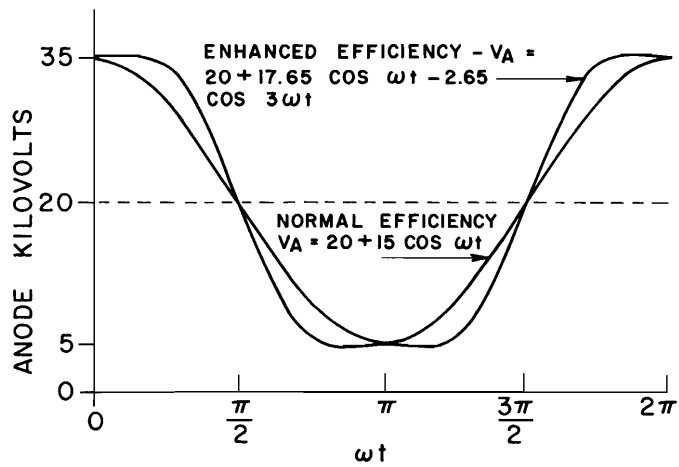

FIGURE 5: Gridded Power Tube Anode Voltage Waveforms