

Proposal to Search for Beauty Particle Production
in Hadronic Interactions

Northwestern - Carnegie Mellon - Fermilab - Notre Dame
Collaboration

September 30, 1979

Spokesman:

R. Ruchti
Department of Physics
University of Notre Dame
Notre Dame, Indiana 46556
(219)/283-6542

Table of Contents

	<u>Page</u>
I. Introduction	2
II. Physics Goals	5
III. Experimental Strategy	10
IV. Trigger Rates and Yields	12
V. Background Estimates	14
VI. Summary	15

I. Introduction

In the fall of 1974 the discovery of the J/Ψ at Brookhaven and SLAC heralded the production of hadrons containing new constituents. An immediate implication of the J/Ψ (interpreted as a bound state of charm-anticharm quarks) was that a large family of related "bare" charm particles should exist. Since 1976, the spectroscopy of these particles has unfolded dramatically, with the observation of numerous charmed mesons and several charmed baryons. A systematic study of the charm system, including analysis of observed states and searches for as yet unobserved states and decay modes, is in progress at several laboratories. One of these experiments, Fermilab E515¹, is a comprehensive survey of charm particle production in 200 GeV/c π^- - Be collisions utilizing a prompt muon trigger.

One naturally expects that a similar familial arrangement exists for the Υ , assumed to be a $b\bar{b}$ bound state, and that a spectroscopy, comparable to the charm system, will emerge in this case as well. One's ability to observe the related states depends, of course, on the cross section for their production and branching ratios for their decay.

Experimental measurements indicate that the cross section for upsilon production in 400 GeV/c nucleon-nucleon collisions is very small:

$$B_{\mu\mu} \frac{d\sigma}{dy} \Big|_{y=0} = 0.18 \times 10^{-36} \text{ cm}^2/\text{nucleon.}^2$$

This cross section is well below the sensitivity range of most experiments other than those triggering on dileptons. However the prospects for "bare" beauty production may not be as bleak as the cross sections for upsilon production by

protons might indicate.

(i) If the recent CERN (Goliath Spectrometer) measurement is borne out, then the observation of the production of B mesons in 200 GeV/c π^- Be collisions and subsequent decay $B \rightarrow \Psi K\pi$ yields a cross section times branching ratio of order: $\sigma_B \cdot B \approx 2$ nb/nucleon.³ If the branching ratio for the decay $B \rightarrow \Psi K\pi$ is of order $\sim 1\%$, then σ_B may be as large as 200 nb.

(ii) More conservatively, one can appeal to two other (less controversial) experimental observations.

(a) Upsilon production by pions is ~ 30 times more effective than production by protons at the same value of \sqrt{s} .⁴ It is reasonable to assume that a similar advantage exists for $b\bar{b}$ production.

(b) The ratio of the cross sections for producing pairs of "bare" particles to inclusive production of the related vector meson is large and appears to increase with increasing constituent mass. For example the ratio:

$$\frac{\sigma_{K\bar{K}}}{\sigma_{\phi}} \approx 20 \text{ at Fermilab energies}^5$$

whereas

$$\frac{\sigma_{D\bar{D}}}{\sigma_{J/\psi}} \approx 75 \text{ in the same energy regime.}^6$$

One might then expect a similar gain from charm to beauty:

$$\frac{\sigma_{B\bar{B}}}{\sigma_T} \geq \frac{\sigma_{D\bar{D}}}{\sigma_{J/\Psi}} .$$

If one then looks for beauty production in π^-Be interactions one obtains the following estimate for the production cross section

$$\begin{aligned} \sigma_{\pi N \rightarrow B\bar{B}X} &\approx \left(\frac{\sigma_{B\bar{B}}}{\sigma_T} \right) \left(\frac{2}{B_{\mu\mu}} \right) \left(\frac{d\sigma}{dy} \Big|_{y=0} \right) \sigma_{\pi N \rightarrow TX} \\ &\approx (75) \times \left(\frac{2}{.035} \right) \times 1.5 \times 10^{-36} \text{ cm}^2/\text{nucleon} \end{aligned}$$

$$\sigma_{\pi N \rightarrow B\bar{B}X} \approx 6.4 \text{ nb/nucleon.}$$

This cross section result is small, and great experimental care is required to make any detailed measurements at all using hadron beams. In addition, the cascade decays of the high mass B mesons which are expected as beauty quarks β -decay into charm and then strange quarks, means that the final state multiplicities will be relatively large.

Provided the trigger scheme is well-considered, one can profitably use large-aperture multiparticle spectrometers, equipped with fast electronic detectors, to search for beauty production. The limitation of these spectrometers lies in their ability to handle beam rates in excess of $10^6 - 10^7$ interactions/spill.

We propose to improve our acceptance substantially (over E515) for decays of heavy high mass particles produced in π^-Be collisions by: first, increasing the vertical acceptance of the forward spectrometer by a factor of two, by shortening the target/magnet distance; second, by a shortened and more powerful Cerenkov counter (ring - imaging) for π and K separation in the momentum range 6 - 25 GeV/c;

third, the reduction in length of the Cerenkov counter will allow us to reduce the distance from target to liquid Argon shower detector by $\sim 25\%$ improving the solid angle coverage for neutral particles and electrons; and fourth, by expansion of forward arm muon coverage by a factor of two. (See Fig. 1 and 2 for a comparison of geometry for E-515 and this proposal.)

The experimental apparatus will be triggered by either of the following possibilities: (i) a muon detected in the upper arm ($\theta_{\text{LAB}} \geq 67$ mr vertically) in conjunction with a positive signal in the forward arm (prompt muon trigger), or (ii) a dimuon detected in the forward arm with angular separation between the muons of ($\theta_{\text{LAB}} \gtrsim 15$ mr vertically) (J/Ψ trigger).

We will require a pion beam of $\approx 2 \times 10^7$ particles per pulse or greater with a beam momentum of at least 200 GeV/c and spot requirements identical to those for E-515. The M1W beam (satisfying the E515 requirements) will be suitable for our needs. Assuming 1000 hours of beam time for data taking, we expect a cross section sensitivity of 48 events/nb in $\mu^\pm e^\mp$ channels and 24 events/nb in $\Psi K\pi$ channels. In order to provide for testing and implementation of new components and contingency, we request 1200 hours of beam for these studies.

II. Physics Goals

(1) Beauty and Other New Flavors

Our strategy will be to search for beauty particle production in the strong interactions via three complementary methods:

For Beauty decays, one expects the opposite case:

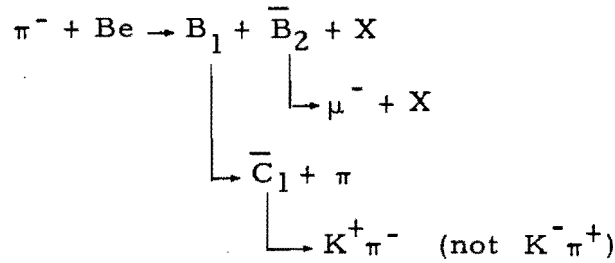

This correlation should dominate at larger p_T ($\gtrsim 1.5 \text{ GeV}/c.$)⁷ Lack of such a correlation in $B^0\bar{B}^0$ systems would indicate $B\bar{B}$ mixing.

The yield of events for associated $B\bar{B}$ production will be, in general, lower than for inclusive B production because there are now two branching ratios and acceptances to be considered ($\bar{B}_2 \rightarrow \mu$, $B_1 \rightarrow \text{hadrons}$). However, the approach is still tractable because the branching ratio for leptonic B decays is expected to be large ($B_\mu \approx 15\%$). The wealth of potential decay channels (in addition to $\Psi K\pi$) makes this approach both appealing and compelling.

(c) Prompt Muon Trigger (Multi-Lepton Correlations)

We intend to measure the cross section for pair production of beauty particles by studying multi-lepton events. As a B meson decays, the cascade from $\bar{b} \rightarrow c \rightarrow \bar{s}$ can produce two charged leptons in the final state. For example:

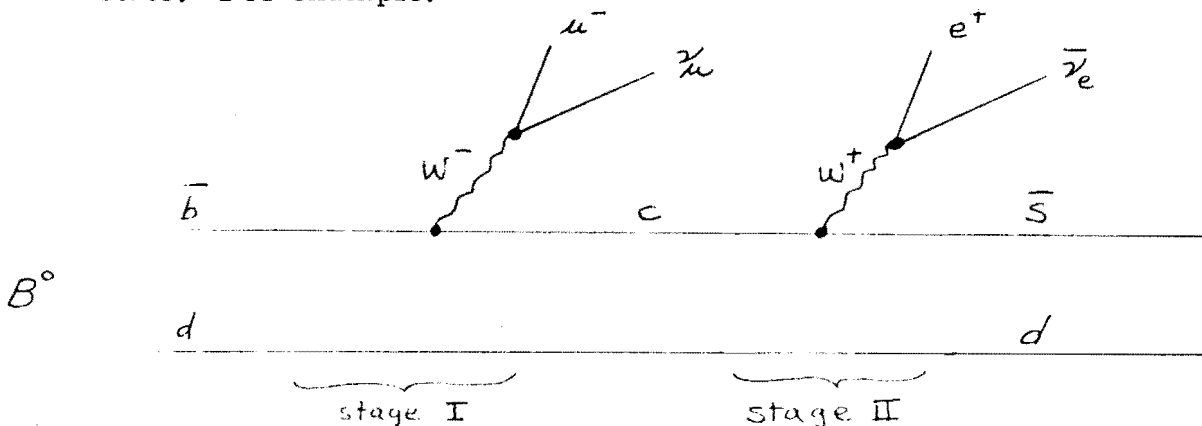

Thus one expects to observe up to four leptons produced by a $B\bar{B}$ pair (ignoring s, \bar{s} decays). In addition the leptons are likely to be accompanied by a pair of Kaons which occur from charm decay.

Of the multi-lepton events, an interesting subset is (μ^\pm, e^\mp) pairs in which each lepton has large transverse momentum $p_T \geq 1.5 \text{ GeV}/c$. These events correspond to leptons produced in the first stage of the cascade $\bar{b} \rightarrow c$ (and $b \rightarrow \bar{c}$ for the \bar{B} decay). At these large p_T values, $\mu^\pm e^\mp$ events from charm decay are extremely unlikely, $\lesssim 10^{-4}$ (see Fig. 3). Additional background in such a sample from π, K and other decays is handled by comparing the yields of opposite sign $(\mu^\pm e^\mp)$ events to like-sign $(\mu^\pm e^\pm)$ events to extract the true signal. For a subset of these events, calculation of the invariant mass of the first stage lepton and the final state Kaon should yield mass values in excess of charm particle masses, indicative of heavy particle production.

(2) Charm Particle Spectroscopy

We plan to extend our measurement of charm particle production and decay distributions begun in E-515, with improved acceptance for high multiplicity decays - particularly decays involving multineutrals. For example, various decay modes for charm meson and baryon decay involve large numbers of secondaries. Increased acceptance for π^0 and η^0 mesons and improved Cerenkov identification for high multiplicity events will aid in the identification of additional decay modes and states.

In the J/Ψ trigger mode, photons accompanying the J/Ψ will be detected in the liquid argon shower detector. There have been several recent measure-

ments of the process $\chi(\sim 3.51) \rightarrow \Psi \gamma$ in the strong interactions with a wide range of results: 11% - 70% of all J/Ψ production occurs through χ states⁹. The good energy resolution of our shower detector will assist in the study of these processes.

III. Experimental Strategy

Our strategy is to optimize our experimental geometry for good acceptance for $B\bar{B}$ production near $x = 0$, to detect hadronic weak decays of B mesons and to measure multilepton correlations with improved acceptance for electrons. This goal must be accomplished without severely limiting the acceptance for trigger muons in the muon arm.

An appropriate compromise for these two requirements is the experimental geometry shown in Fig. 2.

(1) The target to magnet-center distance is shortened to 4 ft., but the 1:2 vertical aspect ratio of the E-515 geometry is still preserved (the beam enters 2.5" above the magnet midplane). This increases the angle for muons accepted in the trigger arm to $\theta_y \gtrsim 67$ mr vertically. The effect of increasing the muon angle reduces the acceptance for muons from semi-muonic decays of B mesons by roughly 30% (see Table 1). However this reduction is more than compensated by the acceptance increase for associated production in the forward arm (+65, -130 mr vertically) - a two fold increase in vertical aperture.

(2) The Cerenkov counter currently in use for E-515 (a 46 cell, atmospheric pressure, N_2 gas counter of 15 ft. length), will be replaced by a shorter counter of $\lesssim 2$ m length, using the same radiator (see Appendix I for further detail).

Cerenkov light will be detected by position sensitive avalanche chambers for ring-imaging instead of conventional photomultiplier tubes. The consequences of this new counter are:

(i) it will provide improved K, π separation for momenta $6 \lesssim P \lesssim 25$ GeV/c - by ring imaging and photon counting.

(ii) its shorter length will allow the liquid argon shower detector (and forward muon detector) to move 25% closer to the experimental target than in the E-515 geometry. This increases both the electron and muon acceptances and shortens the decay length for muons in the forward arm to 9.7 m (important for the J/ Ψ trigger).

(3) The forward arm muon detector ($\mu 1$, an existing proportional tube array with horizontal elements) will be expanded by 50% in both vertical and horizontal dimensions, and an additional array ($\mu 2$) with elements arranged vertically will be added.

(4) Otherwise, the magnetic spectrometer installed for E-515, will be used for this experiment. A few new additions are noted. Currently existing are:

(i) The forward arm PWC system (≥ 12 K wires) up and downstream of a 40D48 spectrometer magnet. To maintain good detection for K_S^0 decays downstream of the target, we will install a PWC module at the center of the magnet.

(ii) The forward arm drift chamber system (200 drift cells) for improved momentum resolution for high momentum secondaries.

(iii) The PWC system for muon tracking and the muon trigger

hodoscopes (M2, M3). The first hodoscope (M1) will need modification in the new geometry.

(iv) The segmented liquid-argon shower detector will be used for electron and neutral detection.

(v) The beam requirements for this experiment are identical to those for E-515. We will require a ≥ 200 GeV/c π^- beam of $\geq 2 \times 10^7$ particles per pulse, focused at the experimental target to 1 mm full vertical width and ≥ 5 cm horizontal width. The vertical profile of the beam is kept narrow to minimize the decay length from the production point in the target to the tungsten, iron absorber in the upward trigger arm, ~ 20 cm (see Fig. 4 for a schematic of the target region).

IV. Trigger Rates and Yields

The detector will be triggered by either of the following alternatives:

(i) a prompt μ^\pm detected in the upper arm and a positive signal in the forward arm, or (ii) a dimuon detected in the forward arm with an angular separation between the muons of ($\theta_{\text{LAB}} \gtrsim 15$ mr vertically).

(1) Prompt Muon Trigger

Trigger rates for this mode will be similar to those for E-515, but the larger angle requirement for muons upward will reduce still further potential π and K decay backgrounds. We anticipate ~ 1.5 muon triggers per 10^5 interactions of which $\gtrsim 50\%$ will be prompt. Assuming a beam of 2×10^7 π^- /pulse and a 10% interaction length target, this yields 30 trigger/spill.

(2) J/ Ψ Dimuon Trigger

For the dimuon trigger, the key factor is the distance from target

to forward muon absorber, ~ 9.7 m. We anticipate a comparable number of dimuon triggers ~ 20 per 10^5 interactions in this mode which translates into 40 triggers/spill. During 1000 hours of active data taking, we would expect to collect ~ 2000 J/Ψ events.

Of the two trigger schemes, the prompt muon trigger will be given priority, since this technique is sensitive to associated production and hence constitutes an "unbiased" search for beauty decays, rather than specializing to a specific decay mode. If, for example, the beam flux could be increased above 2×10^7 π^- /spill, we could dial down the J/Ψ trigger to avoid any potential rate limitations in the system.

In Table I, we present the results of a Monte Carlo analysis of the acceptance of the proposed geometry for various beauty decays and, for comparison, a similar analysis for E-515. In Table II, we indicate the yield of events expected per nanobarn of cross section in various topologies.

Assuming a beauty cross section of 6.4 nb/nucleon in 200 GeV/c π^- Be collisions we would obtain in 1000 hours of data taking:

- i) ~ 150 events of the type: $B \rightarrow \Psi K \pi$
 $\rightarrow \mu^+ \mu^-$ and $e^+ e^-$
- ii) ~ 300 events of the type: $B \rightarrow \mu^+$ (or e^+) + . . .
 $\bar{B} \rightarrow \mu^-$ (or e^-) + . . .
- iii) ~ 50 four lepton events.

V. Background Estimates

(1) Prompt Muon Trigger

(i) $\Psi K\pi$ mode

To assess our background levels in the $\Psi K\pi$ channels for B decay, we anticipate similar yields to those observed in Goliath³:

- a) our acceptance is similar, although Goliath has 30% greater vertical aperture.
- b) decay lengths in the forward arm for muons are the same: target to hadron filter distance is ~ 10 m.
- c) we however will have μ^\pm sign correlation which should reduce combinatorials at the $\sim 25\%$ level.

Hence we expect ≈ 20 background events per 50 MeV bin in specific decay modes for a B mass of ~ 5300 MeV. Combining all possible modes together to search for a signal, for example adding ($\Psi K^0 \pi^+$, $\Psi K^0 \pi^-$, $\Psi K^+ \pi^-$, $\Psi K^- \pi^+$, $\Psi K^0 \pi^0$), we would obtain a total of roughly 100 events per 50 MeV bin.

Assuming that beauty production occurs at the $6.4 \mu\text{b}$ level, and that the 150 true B decay events of the type $\Psi K\pi$ occur in a bin of twice the mass resolution (100 MeV), we expect:

$$\text{Signal} = 150/100 \text{ MeV}$$

$$\text{Bkgd} = 200/100 \text{ MeV}$$

or $\sim 8.0 \sigma$ effect.

(ii) Lepton-lepton correlations

Here the topologies are unusual-electromagnetic processes cannot contribute, but decays which feed into the signal ($\mu^\pm e^\mp$) channel can be eliminated by subtracting the yield of like sign $\mu^\pm e^\pm$ events away. Contribution from charm decays to (μ, e) events with large p_T per particle are very small as noted earlier.

VI. Summary

The cascade decay of beauty mesons into lower mass states will occur with attendant large multiplicity. Charm particles, strange particles, and multileptons are expected to appear. Our detector, as outlined above, has great strengths in the detection of these states. We therefore believe that this experiment will be a definitive probe into the production of beauty particles in the strong interactions. We request 1200 hours of beam time for the execution of this program.

Table I

Monte Carlo Calculations of Event Acceptances
for This Experiment and E-515

<u>Mode</u>	<u>E-515</u>	<u>This Proposal</u>
$B \rightarrow \Psi K \pi$ $\quad \quad \quad \downarrow$ $\quad \quad \quad \mu^+ \mu^-$	4%	15% (untriggered) 7% (triggered)
$B \rightarrow D e \nu$ $\quad \quad \quad \downarrow$ $\quad \quad \quad \text{obs } e$	35%	60%
$B \rightarrow D \mu \nu$ $\quad \quad \quad \downarrow$ $\quad \quad \quad \text{obs } \mu$ $\quad \quad \quad \text{forward}$	35%	60%
$B \rightarrow D \mu \nu$ $\quad \quad \quad \downarrow$ $\quad \quad \quad \text{obs } \mu$ $\quad \quad \quad \text{upward}$ $\quad \quad \quad *(trigger)$	14%	11%
$B \rightarrow D \bar{D} K$ $\quad \quad \quad \downarrow$ $\quad \quad \quad \begin{array}{l} \downarrow K \pi \\ \bar{K} \pi \end{array}$	4.5%	8%
$B \rightarrow D \pi$ $\quad \quad \quad \downarrow$ $\quad \quad \quad \bar{K} \pi$	10.5%	18%
$B \rightarrow D \bar{D} K$ $\quad \quad \quad \downarrow$ $\quad \quad \quad \begin{array}{l} \downarrow K \\ \bar{K} \end{array}$ $\quad \quad \quad \text{observe all 3}$ $\quad \quad \quad \text{Kaons}$	10%	14%

Table II

Estimates of Event Yields for This Experiment for Various Topologies. (Yields are in events/nb) Assuming 1000 Hours of Beam.

<u>Mode</u>	<u>E-515</u>	<u>This Proposal</u>
<u>J/Ψ Trigger</u>		
(1) $B \rightarrow \Psi K\pi$ $\quad \quad \quad \swarrow$ $\quad \quad \quad \mu^+ \mu^-$ $\quad \quad \quad \text{trigger}$	3	13
<u>Prompt Muon Trigger</u>		
(1) $B \rightarrow \bar{D} \mu \nu$ $\quad \quad \quad \swarrow$ $\quad \quad \quad \text{trigger}$ $\quad \quad \quad \bar{B} \rightarrow \Psi K\pi$ $\quad \quad \quad \quad \quad \quad \swarrow$ $\quad \quad \quad \quad \quad \quad \mu^+ \mu^-$ $\quad \quad \quad \quad \quad \quad \text{or } e^+ e^-$	3	11
(2) $B \rightarrow D \mu \nu$ $\quad \quad \quad \swarrow$ $\quad \quad \quad \text{trigger}$ $\quad \quad \quad \bar{B} \rightarrow D \bar{D} K$ $\quad \quad \quad \quad \quad \quad \swarrow$ $\quad \quad \quad \quad \quad \quad K\pi$ $\quad \quad \quad \quad \quad \quad \bar{K}\pi$	< 1.5	< 3.3
(3) $B \rightarrow \bar{D} \mu \nu$ $\quad \quad \quad \swarrow$ $\quad \quad \quad \text{trigger}$ $\quad \quad \quad \ell_1^{+---}$ $\quad \quad \quad \bar{B} \rightarrow D \ell_2 \nu$ $\quad \quad \quad \quad \quad \quad \swarrow$ $\quad \quad \quad \quad \quad \quad \ell_3^{+---}$ detect all four leptons	3.0	7.4

(continued on next page)

Table II (cont'd)

<u>Mode</u>	<u>E-515</u>	<u>This Proposal</u>
(4) $B \rightarrow D_{\mu} \nu$ └─ trigger	30	50
$\bar{B} \rightarrow D e \nu$ └─ obs e		

require $p_T^{\mu, e} > 1.5 \text{ GeV}/c$

References

1. Fermilab Experiment E-515. A study of charm particles produced in hadronic interactions, Northwestern-Carnegie Mellon-Fermilab-Notre Dame Collaboration. This experiment will begin taking beam in November, 1979.
2. S. W. Herb et al., Phys. Rev. Lett. 39, 252 (1977) and W. Innes et al., Phys. Rev. Lett. 39, 1240 (1977).
3. R. Barate et al., Possible Observation of a New Meson at 5.3 GeV/c², paper submitted to the 1979 International Symposium on Lepton and Photon Interactions at High Energy, Batavia, Illinois (August, 1979).
4. J. Badier et al., CERN/EP 79-88 (August, 1979).
5. K. J. Anderson et al., Phys. Rev. Lett. 37, 799 (1976); V. Blobel et al., Phys. Lett. 59B, 88 (1975).
6. Based on $\sigma_T(J/\Psi) = \frac{2}{B_{\mu\mu}} \frac{d\sigma}{dy} \Big|_{y=0} \approx 280 \text{ nb/nucleon}$ for pions of 200 GeV/c momentum, and $\sigma_{D\bar{D}} \approx 21 \text{ nb/nucleon}$. The latter value reported recently at the 1979 International Symposium on Lepton and Photon Interactions at High Energy, Batavia, Illinois (August, 1979).
7. These arguments assume that $D^0\bar{D}^0$ mixing and $B^0\bar{B}^0$ mixing are small. There is at present no evidence for $D^0\bar{D}^0$ mixing. It may be however that $B^0\bar{B}^0$ mixing can occur. (See reference 8 below.) Such mixing will then influence the sign correlations for the neutral B mesons.
8. Mary K. Gaillard, Fermilab-Conf-78/64-Thy.
9. T. B. W. Kirk et al., Phys. Rev. Lett. 42, 619 (1979); J. Cobb et al., Phys. Lett. 72B, 497 (1978); A. G. Clark et al., Nucl. Phys. B142, 29 (1978); and Y. Lemoigne et al., The Cascade $\chi(3515) \rightarrow J/\Psi \gamma$ in π^- Be Collisions at $\sqrt{s} = 17.8 \text{ GeV}$, paper submitted to the 1979 International Symposium on Lepton and Photon Interactions at High Energies, Batavia, Illinois (August, 1979).

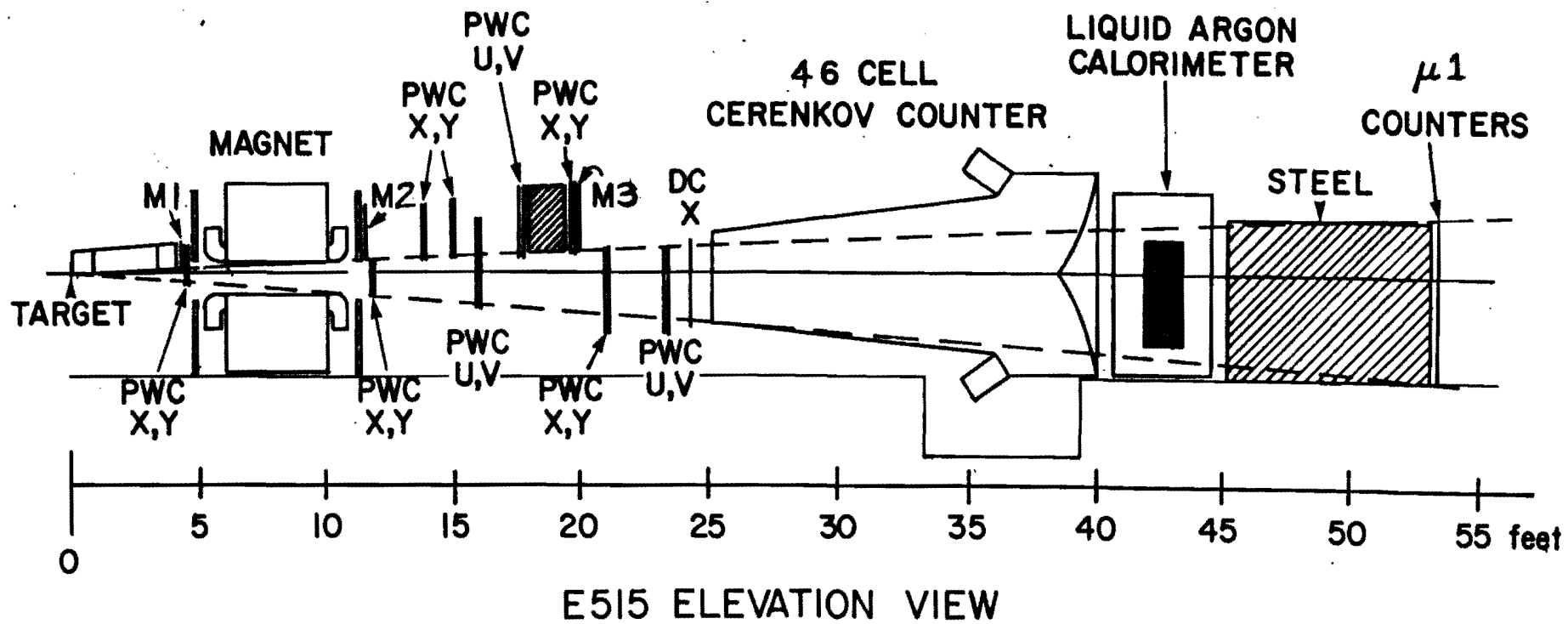

Fig. 1

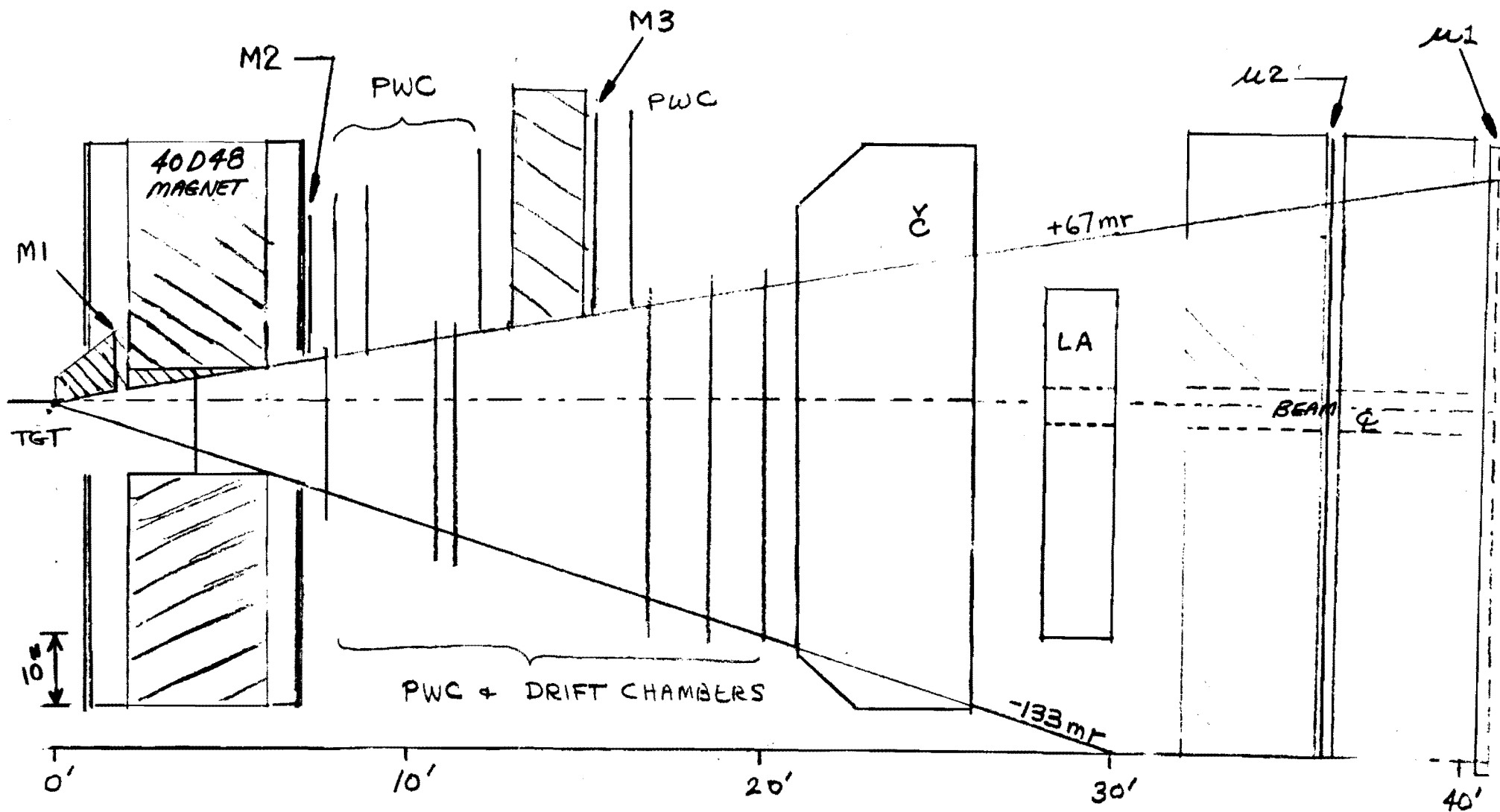
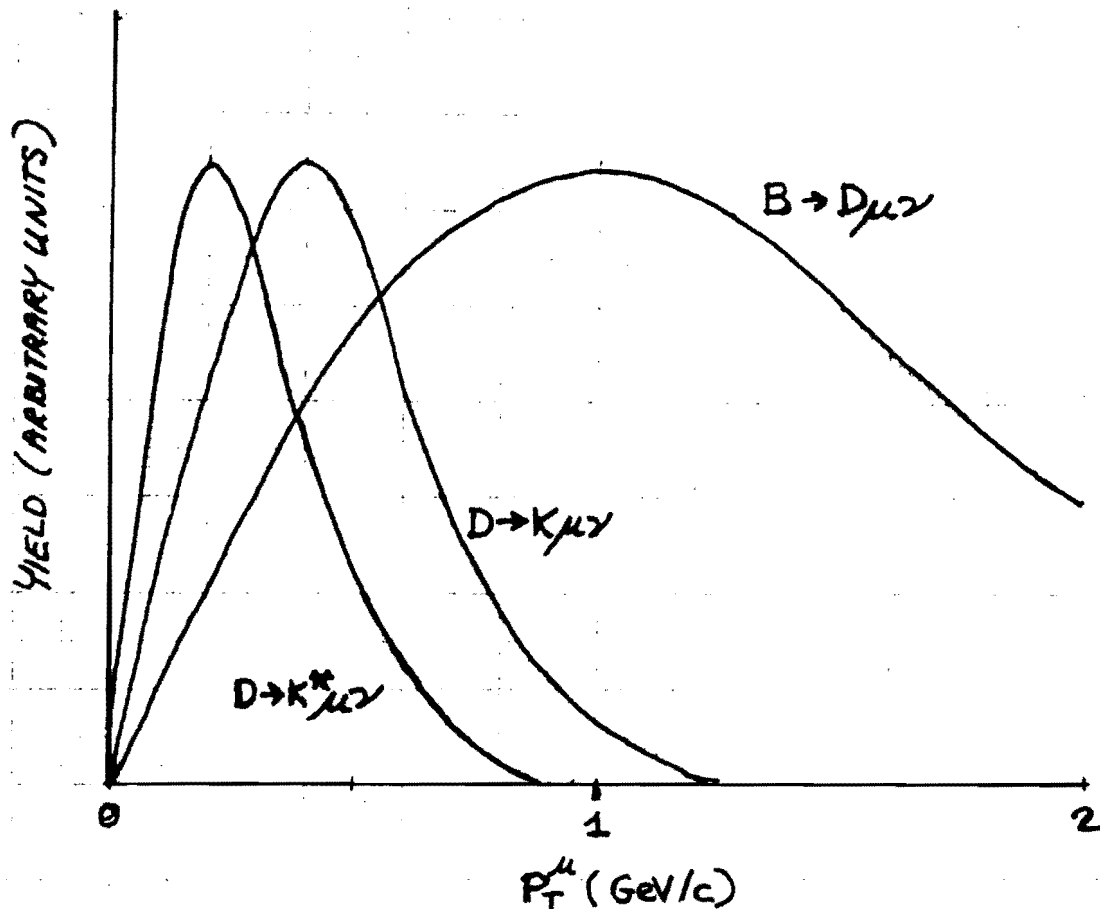

Fig. 2

EXPERIMENTAL LAYOUT (ELEVATION)



Phase space decay of the parent particle is assumed.

for D decays $\langle P_T^\mu \rangle \simeq 0.2$ $D \rightarrow K^* \mu \nu$
 $\simeq 0.4$ $D \rightarrow K \mu \nu$

for B decay $\langle P_T^\mu \rangle \simeq 1.0$ $B \rightarrow D \mu \nu$

(see also reference 8)

Fig. 3

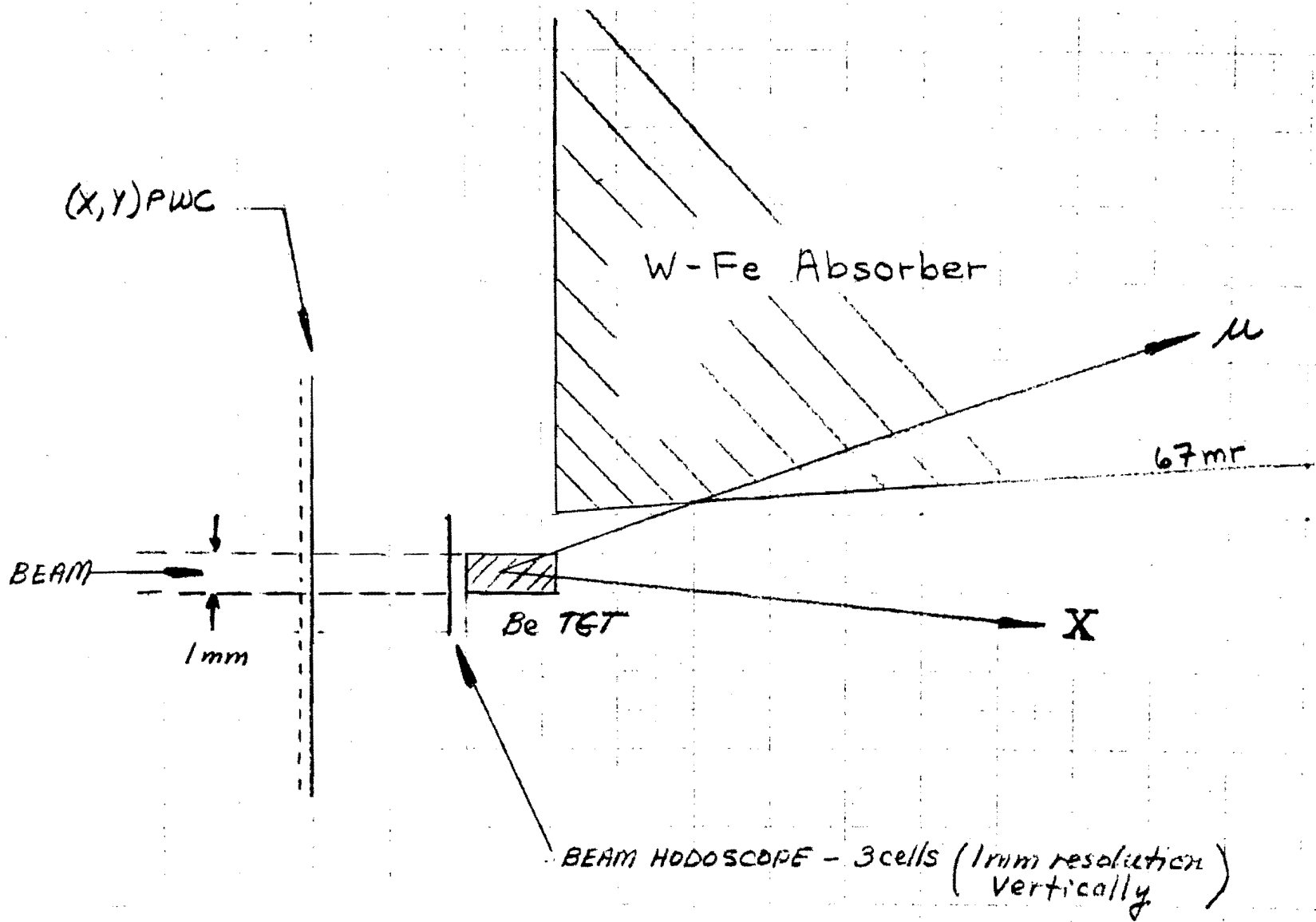

Fig. 4

SCHEMATIC OF TARGET REGION
(ELEVATION)

Appendix I

Cerenkov Detection

The existing E-515 Cerenkov counter will be replaced by a ~ 2 m long, atmospheric nitrogen counter using multistep, avalanche chambers¹ as detector elements rather than conventional photomultipliers (see Fig. A1). Light will be focused from spherical mirrors ($r \approx 2$ m) onto chambers which are situated at the focal plane. The mirrors will be MgF₂ coated aluminum for maximal UV reflectivity.

The chambers, schematically illustrated in Fig. A2, have a pre-amplification and transfer element and final stage PWC detector element. Photons pass into the chamber through a thin ($\lesssim 2$ mm) MgF₂ window and photoionize in the gas (argon with benzene). Quantum efficiency in the UV region will be superior to photomultipliers (factor 2 - 3)². Read out of the ring will be effected by capacitive coupling (cathode-readout) onto pick up pads. Pad sizes of order 5 x 5 mm or less will be tested, to settle on the appropriate geometry which is dictated by wire spacing and gap width³.

We are currently developing avalanche chambers at Notre Dame and in collaboration with M. Atac at Fermilab. Based upon preliminary measurements with one chamber in the lab, fast pulses of 0.1 - 1.0 mV size can be obtained, depending upon voltage conditions.

We intend to test the chamber detector system in the M-5 test beam during fall/winter 1979. Details for a readout system are also currently under study.

References for Appendix I

1. G. Charpak and F. Sauli, Phys. Lett. 78B, 523 (1978); G. Charpak et al., Nuc.Instr. and Meth. 164, 419 (1979).
2. D. Chapman et al., Nuc. Instr. and Meth. 158, 187 (1979).
3. E. Gatti et al., Nuc. Instr. and Meth. 163, 83 (1979).

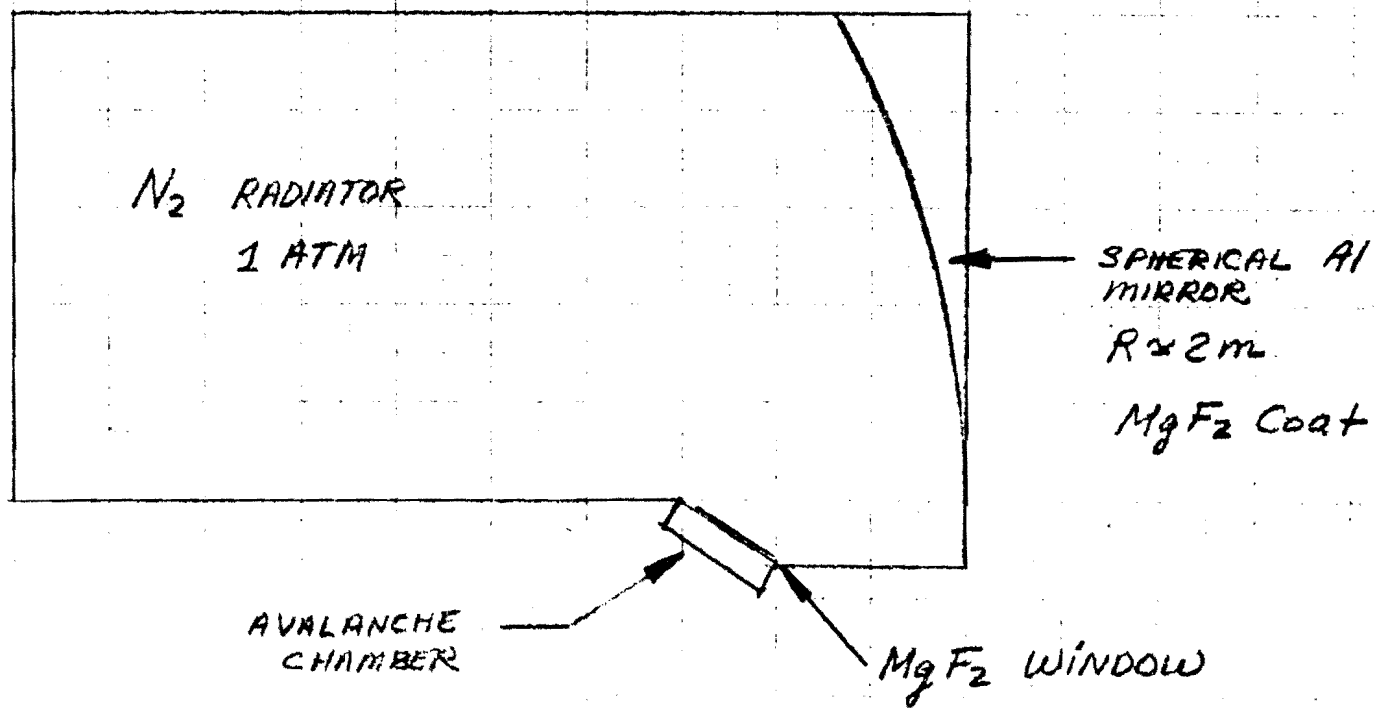

Fig. A1

SCHEMATIC OF \dot{C} -COUNTER CELL

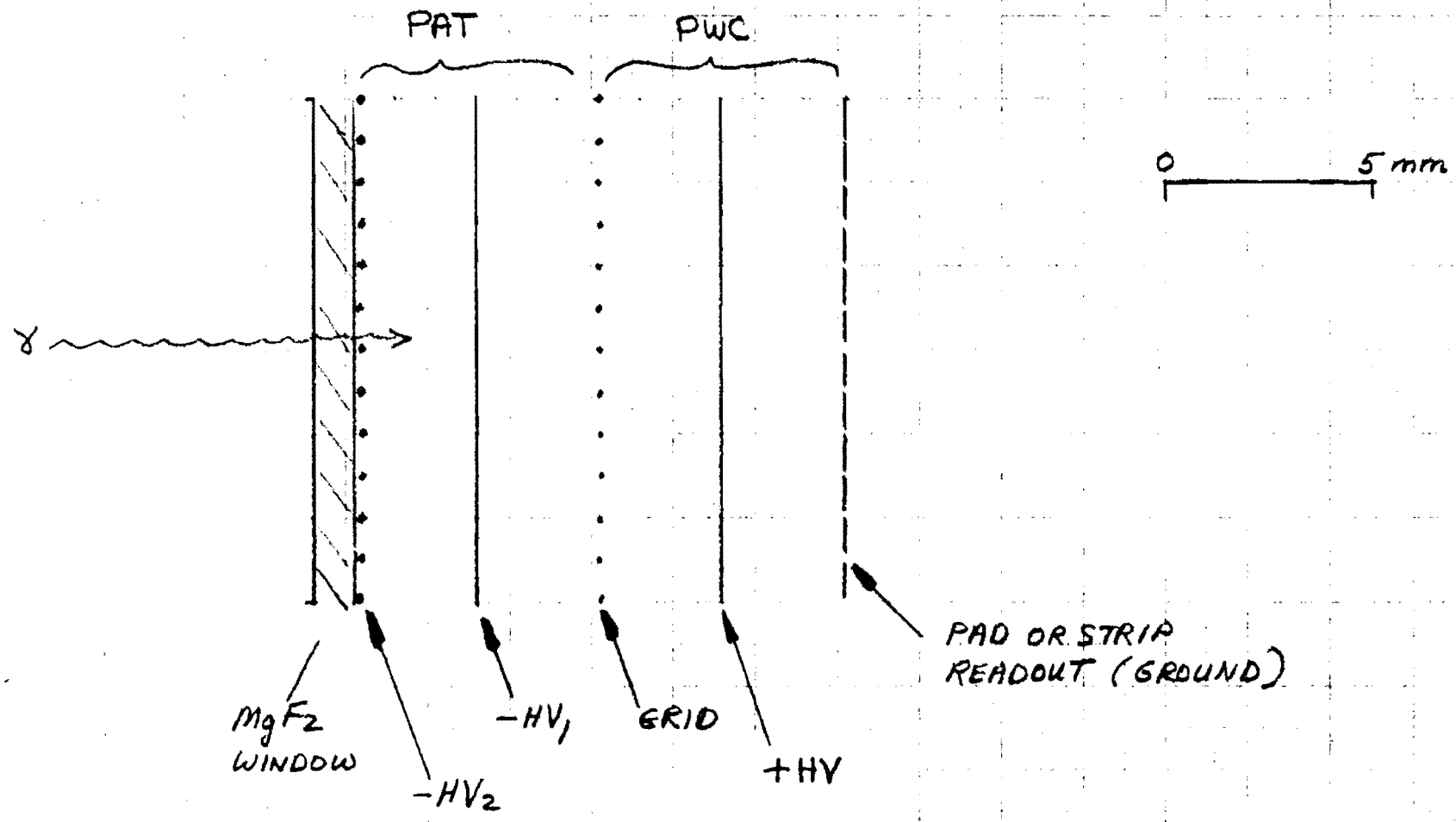

Fig. A2

SCHEMATIC OF AVALANCHE DETECTOR
GAS FILL ARGON + BENZENE

P-628

RECEIVED
OCT 4 1979
DIRECTORS OFFICE
FERMILAB

Batavia, Illinois
October 4, 1979

Dr. Thomas Groves
Fermi National Accelerator Laboratory
Batavia, Illinois 60510

Dear Tom:

I am enclosing several correction pages for Proposal 628. It was noticed that the data rates were calculated for 10^8 beam instead of the proposed 2×10^7 beam. This affected primarily table II and statements of experimental sensitivity. A few other minor corrections are also included.

I am sorry for the inconvenience to you in this matter. I am enclosing 30 copies of the corrections.

Sincerely yours,



Randal Ruchti

(214)-283-6542

or FNAL X 3362

$$\frac{\sigma_{B\bar{B}}}{\sigma_T} \geq \frac{\sigma_{D\bar{D}}}{\sigma_{J/\Psi}} .$$

If one then looks for beauty production in π^-Be interactions one obtains the following estimate for the production cross section

$$\begin{aligned} \sigma_{\pi N \rightarrow B\bar{B}X} &\approx \left(\frac{\sigma_{B\bar{B}}}{\sigma_T} \right) \left(\frac{2}{B_{\mu\mu}} \right) \left(\frac{d\sigma}{dy} \Big|_{y=0} \right) \sigma_{\pi N \rightarrow TX} \\ &\approx (75) \times \left(\frac{2}{.035} \right) \times 2.1 \times 10^{-36} \text{ cm}^2/\text{nucleon} \end{aligned}$$

$$\sigma_{\pi N \rightarrow B\bar{B}X} \approx 9.0 \text{ nb/nucleon.}$$

This cross section result is small, and great experimental care is required to make any detailed measurements at all using hadron beams. In addition, the cascade decays of the high mass B mesons which are expected as beauty quarks β -decay into charm and then strange quarks, means that the final state multiplicities will be relatively large.

Provided the trigger scheme is well-considered, one can profitably use large-aperture multiparticle spectrometers, equipped with fast electronic detectors, to search for beauty production. The limitation of these spectrometers lies in their ability to handle beam rates in excess of $10^6 - 10^7$ interactions/spill.

We propose to improve our acceptance substantially (over E515) for decays of heavy high mass particles produced in π^-Be collisions by: first, increasing the vertical acceptance of the forward spectrometer by a factor of two, by shortening the target/magnet distance; second, by a shortened and more powerful Cerenkov counter (ring - imaging) for π and K separation in the momentum range 6 - 25 GeV/c;

third, the reduction in length of the Cerenkov counter will allow us to reduce the distance from target to liquid Argon shower detector by $\sim 25\%$ improving the solid angle coverage for neutral particles and electrons; and fourth, by expansion of forward arm muon coverage by a factor of two. (See Fig. 1 and 2 for a comparison of geometry for E-515 and this proposal.)

The experimental apparatus will be triggered by either of the following possibilities: (i) a muon detected in the upper arm ($\theta_{\text{LAB}} \geq 67$ mr vertically) in conjunction with a positive signal in the forward arm (prompt muon trigger), or (ii) a dimuon detected in the forward arm with angular separation between the muons of ($\theta_{\text{LAB}} \gtrsim 15$ mr vertically) (J/Ψ trigger).

We will require a pion beam of $\approx 2 \times 10^7$ particles per pulse or greater with a beam momentum of at least 200 GeV/c and spot requirements identical to those for E-515. The M1W beam (satisfying the E515 requirements) will be suitable for our needs. Assuming 1000 hours of beam time for data taking, we expect a cross section sensitivity of 77 events/nb in $\mu^\pm e^\mp$ channels and 2.7 events/nb in $\Psi K\pi$ channels. In order to provide for testing and implementation of new components and contingency, we request 1200 hours of beam for these studies.

II. Physics Goals

(1) Beauty and Other New Flavors

Our strategy will be to search for beauty particle production in the strong interactions via three complementary methods:

For Beauty decays, one expects the opposite case:

$$\pi^- + B_e \rightarrow B_1 + \bar{B}_2 + X$$

$$\begin{array}{l} \downarrow \\ \mu^- + X \\ \downarrow \\ \bar{C}_1 + \pi \\ \downarrow \\ K^+ \pi^- \quad (\text{not } K^- \pi^+) \end{array}$$

This correlation should dominate at larger p_T ($\geq 1.5 \text{ GeV}/c$).⁷ Lack of such a correlation in $B^0\bar{B}^0$ systems would indicate $B\bar{B}$ mixing.

The yield of events for associated $B\bar{B}$ production will be, in general, lower than for inclusive B production because there are now two branching ratios and acceptances to be considered ($\bar{B}_2 \rightarrow \mu$, $B_1 \rightarrow \text{hadrons}$). However, the approach may be tractable because the branching ratio for leptonic B decays is expected to be large ($B_\mu \approx 15\%$). The wealth of potential decay channels (in addition to $\Psi K\pi$) makes this approach both appealing and compelling.

(c) Prompt Muon Trigger (Multi-Lepton Correlations)

We intend to measure the cross section for pair production of beauty particles by studying multi-lepton events. As a B meson decays, the cascade from $\bar{b} \rightarrow c \rightarrow \bar{s}$ can produce two charged leptons in the final state. For example:

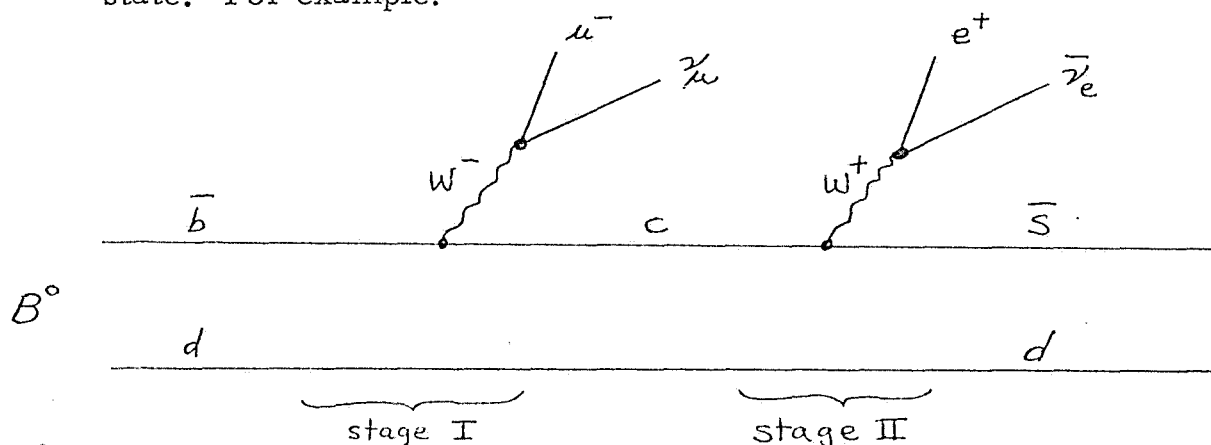

to forward muon absorber, ~ 9.7 m. We anticipate a comparable number of dimuon triggers ~ 20 per 10^5 interactions in this mode which translates into 40 triggers/spill. During 1000 hours of active data taking, we would expect to collect $\sim 20\,000$ J/Ψ events.

In Table I, we present the results of a Monte Carlo analysis of the acceptance of the proposed geometry for various beauty decays and, for comparison, a similar analysis for E-515. In Table II, we indicate the yield of events expected per nanobarn of cross section in various topologies.

Assuming a beauty cross section of $.9$ nb/nucleon in 200 GeV/c π^- Be collisions we would obtain in 1000 hours of data taking:

- i) ~ 24 events of the type: $B \rightarrow \Psi K \pi$
 $\rightarrow \mu^+ \mu^-$ and $e^+ e^-$
- ii) ~ 760 events of the type: $B \rightarrow \mu^+ \text{ (or } e^+) + \dots$
 $\bar{B} \rightarrow \mu^- \text{ (or } e^-) + \dots$
 ~ 75 events with $p_t^{\text{lept.}} \gtrsim 1.5$ GeV/c
- iii) ~ 8 four lepton events.

If beauty occurs at the ~ 25 nb level, then we would observe ~ 66 events in the $B \rightarrow \Psi K \pi$ mode, corresponding to a 4σ effect. If the momentum of the beam could be increased above 200 GeV/c while retaining a high flux level, we would expect our event yields to increase substantially.

V. Background Estimates

(1) Prompt Muon Trigger

(i) $\Psi K\pi$ mode

To assess our background levels in the $\Psi K\pi$ channels for B decay, we anticipate similar yields to those observed in Goliath³:

- a) our acceptance is similar, although Goliath has 30% greater vertical aperture.
- b) decay lengths in the forward arm for muons are the same: target to hadron filter distance is ~ 10 m.
- c) we however will have μ^\pm sign correlation which should reduce combinatorials at the $\sim 25\%$ level.

Hence we expect ≈ 20 background events per 50 MeV bin in specific decay modes for a B mass of ~ 5300 MeV. Combining all possible modes together to search for a signal, for example adding ($\Psi K^0 \pi^+$, $\Psi K^0 \pi^-$, $\Psi K^+ \pi^-$, $\Psi K^- \pi^+$, $\Psi K^0 \pi^0$), we would obtain a total of roughly 100 events per 50 MeV bin.

Assuming that beauty production occurs at the 25 nb level, and that the 66 true B decay events of the type $\Psi K\pi$ occur in a bin of twice the mass resolution (100 MeV), we expect:

$$\text{Signal} = 66 / 100 \text{ MeV}$$

$$\text{Bkgd} = 200 / 100 \text{ MeV}$$

or $\sim 4.0 \sigma$ effect.

Table II

Estimates of Event Yields for This Experiment for Various Topologies. (Yields are in events/nb) Assuming 1000 Hours of Beam.

<u>Mode</u>	<u>E-515</u>	<u>This Proposal</u>
<u>J/Ψ Trigger</u>		
(1) $B \rightarrow \Psi K\pi$ $\quad \quad \quad \downarrow$ $\quad \quad \quad \mu^+ \mu^-$ $\quad \quad \quad \text{trigger}$	0.23	2.52
<u>Prompt Muon Trigger</u>		
(1) $\left\{ \begin{array}{l} B \rightarrow \bar{D} \mu \nu \\ \quad \quad \quad \downarrow \\ \quad \quad \quad \text{trigger} \\ \bar{B} \rightarrow \Psi K\pi \\ \quad \quad \quad \downarrow \\ \quad \quad \quad \mu^+ \mu^- \\ \quad \quad \quad \text{or } e^+ e^- \end{array} \right.$	0.05	0.17
(2) $\left\{ \begin{array}{l} B \rightarrow D \mu \nu \\ \quad \quad \quad \downarrow \\ \quad \quad \quad \text{trigger} \\ \bar{B} \rightarrow D \bar{D} K \\ \quad \quad \quad \downarrow \\ \quad \quad \quad \begin{array}{l} \downarrow K\pi \\ \downarrow \bar{K}\pi \end{array} \end{array} \right.$	< 0.12	< 0.24
(3) $\left\{ \begin{array}{l} B \rightarrow \bar{D} \mu \nu \\ \quad \quad \quad \downarrow \\ \quad \quad \quad \text{trigger} \\ \quad \quad \quad \downarrow \\ \quad \quad \quad \ell_1^{+---} \\ \bar{B} \rightarrow D \ell_2 \nu \\ \quad \quad \quad \downarrow \\ \quad \quad \quad \ell_3^{+--} \\ \text{detect all four leptons} \end{array} \right.$	0.29	0.72

(continued on next page)

Table II (cont'd)

<u>Mode</u>	<u>E-515</u>	<u>This Proposal</u>
(4) $B \rightarrow D \mu \nu$ └ trigger	46	77
$\bar{B} \rightarrow D e \nu$ └ obs e		
require $p_T^{\mu, e} > 1.5 \text{ GeV}/c$	5	8.5