

NAL PROPOSAL No. 67

Correspondent: B. Maglic
Department of Physics
Rutgers University
New Brunswick, N.J. 0890

FTS/Off-net 201-846-4500
247-1766 Ext. 2531

SEARCH FOR BARYON RESONANCES UP TO 10 GeV MASS
PRODUCED IN $p+p \rightarrow p+MM$ WITH A RESOLUTION OF ± 25 MeV

K. Cohen, W. E. Ellis, R. Esterling, B. Maglic, J. Norem,
C. Rosenberg, F. Sannes, M. Silverman and K. Vosburgh
Rutgers University
George Cvijanovich
Upsala College

June, 1970

Preliminary Proposal for National Accelerator Laboratory

Search for Baryon Resonances up to 10 GeV Mass

Produced in $p+p \rightarrow p+MM$ With a Resolution of ± 25 MeV

K. Cohen, W. E. Ellis, R. Esterling, B. Maglic, J. Norem,
C. Rosenberg, F. Sannes, M. Silverman and K. Vosburgh
Rutgers, the State University of New Jersey

George Cvijanovich

Upsala College, New Jersey

ABSTRACT

A simple magnet-less missing-mass experiment is proposed to investigate the mass-spectrum of non-strange baryons of isospins $1/2$ and $3/2$ in the mass-range from 4 to 10 GeV with a resolution of ± 25 MeV or better.

The spacing between baryons expected from the empirical interval rule $\Delta M^2 \approx 1 \text{ BeV}^2$ is 125 and 50 MeV for masses of 4 and 10 GeV respectively; if the rule holds, one expects $10^2 - 4^2 = 84$ resonances in this range.

We plan to use the reaction $p + p \rightarrow p + MM$ and to detect the recoil protons in the region of the Jacobian peak. The protons of momenta from 400 to 850 MeV/c are selected by means of time-of-flight, range, and pulse height and are recorded in a pulse height analyzer. Since no magnets, wire planes, computers or any other major facilities are needed, the experiment can be done as soon as the beam, either full extracted (Option 1) or secondary diffracted (Option 2) or internal (Option 3) is available.

OPTION 1:

The extracted proton beam of 10^{13} /pulse is incident on either a H₂ gas jet or CH₂ foil acting as point targets. A 100-element hodoscope at a distance of 15 feet measures the angular distribution of recoil protons in the region of "Jacobian peaks", which gives the mass spectrum directly. For this option, an enlarged area near Exit G-1 or Exit G-2 could be used.

OPTION 2:

The diffracted proton beam of 10^{10} /pulse is incident on a liquid hydrogen target 1 cm long, viewed by the 100-element hodoscope.

OPTION 3:

The internal beam is incident on a H₂ gas jet during the acceleration. A novel technique using one range telescope consisting of 5 counters is proposed to investigate the same mass-spectrum of baryons as in Options 1 and 2, with similar mass resolution. Recoil protons of fixed momentum, 650 MeV/c ($\beta = 0.6$), at a fixed laboratory angle (55°) are selected by the telescope in the region of the Jacobian peak. At each passage of the beam the emission of the proton corresponds to different and definite value of the missing-mass, M_{N^*} . The time of each event is recorded; since it is proportional to the proton energy during the acceleration, the distribution of trigger times gives the N^* -spectrum directly.

I. Physics Justification and Aims

We propose to investigate the missing-mass spectrum of the recoil proton emitted backward in the center-of-mass in the reaction

$$P_1 + P_2 \rightarrow P_3 + (MM)^+ \quad (1)$$

where $(MM)^+$ is a baryon resonance of isotropic spin $I = \frac{1}{2}$ or $\frac{3}{2}$.

The search for heavy baryon resonances in the unexplored region above 4 GeV mass is expected to bring answers to the following questions:

- Do baryon resonances above $M = 4$ GeV exist?
- If so, are they only a small fraction of the inelastic cross-section or is the other extreme, "multiresonance dominance" assumption, valid there? (See e.g. Harari¹: "Is everything made out of resonances?")
- How far in mass does the empirical linear relation between M^2 and spin hold? Will the Regge trajectory begin to bend over at a certain mass; if so, which way? (We will check this by investigating how far the equal mass-spacing persists).
- How do the physical widths of the baryon resonances change with mass M ? Do they get broader or narrower? (See e.g. Goldberg²: "Will the resonances on the leading trajectories become stable to strong decay at high spin?")

Assuming that the empirical interval rule

$$\Delta M^2 \approx 1 \text{ GeV}^2 \quad (2)$$

holds at heavy masses, the expected separation between peaks will be

$$125 \text{ MeV at } M = 4 \text{ GeV} \quad (3)$$

$$50 \text{ MeV at } M = 10 \text{ GeV} \quad (4)$$

These numbers dictate that the resolution, Γ_{res} , in the experiment should be:

$$\Gamma_{\text{res}} \leq |\pm 62 \text{ MeV}| \text{ at } M = 4 \text{ GeV} \quad (5)$$

$$\Gamma_{\text{res}} \leq |\pm 25 \text{ MeV}| \text{ at } M = 10 \text{ GeV} \quad (6)$$

The proposed experiment will provide almost twice as good resolution as the values (5-6) [See Tables 2,3].

The number of peaks, expected on the basis of (2), in the region between $M=4 \text{ GeV}$ and $M=10 \text{ GeV}$ is $10^2 - 4^2 = 84$.

II. Experimental Method

The experiment can be performed in any one of three proton beams:

- the extracted beam of 10^{13} protons/pulse (OPTION 1);
- the diffracted beam of 10^{10} protons/pulse (OPTION 2);
- the internal beam inside the main ring (OPTION 3).

Options 1 and 2 are the "old" versions of the "Jacobian peak" method³ in which the incident proton momentum p_1 is fixed and different recoil angles θ_3 are measured (Fig. 1). The essential points of the measurement are that the angular distribution of the low momentum protons emitted at large angles gives directly the missing-mass distribution and that the angular resolution determines almost entirely the mass-resolution (Fig. 5).

Option 3 is a novel application of the method. If the experiment is done in the internal beam during the acceleration (Fig. 6), the hodoscope may be reduced to one element (i.e. no hodoscope is needed). In this case the variable is the incident proton momentum p_1 ; both the recoil angle θ_3 and recoil momentum p_3 are fixed³. This method uses the fact that at the maximum angle the recoil momentum is constant to 5% while the bombarding energy changes from 20 to 200 GeV. This is shown in Fig. 3.

Mass Resolution: The mass-resolution, M , is the sum of three terms

$$\Delta M^2 = \left(\frac{\partial M}{\partial p_3}\right)^2 \Delta p_3^2 + \left(\frac{\partial M}{\partial p_1}\right)^2 \Delta p_1^2 + \left(\frac{\partial M}{\partial \theta_3}\right)^2 \Delta \theta_3^2 \quad (8)$$

The first (dependence on recoil proton momentum) is zero at the maximum angle and negligible over the angular interval $\Delta \theta_3$ used.

$$\frac{\partial M}{\partial p_3} = 0 \text{ at } \theta_3 = \theta_3(\text{Max}) \quad (9)$$

The second term (dependence on incident proton momentum p_1) is negligible in comparison to the third term (dependence on recoil angle θ_3), which is

$$\frac{\partial M}{\partial \theta_3} = \begin{cases} 9 \frac{\text{MeV}}{\text{mrad}} \text{ at } 100 \text{ GeV/c} & (10a) \\ 13 \frac{\text{MeV}}{\text{mrad}} \text{ at } 200 \text{ GeV/c} & (10b) \end{cases}$$

so that only θ_3 needs to be measured accurately. Since the momenta of the recoil protons are relatively low (400 to 850 MeV/c), the limiting factor in the measurement of θ_3 is multiple Coulomb scattering. The mass resolution as a function of incident momentum and missing mass is given in Tables 2 and 3 and in Figure 4.

Selection of the "correct" protons without magnetic analysis

The method requires the identification of the proton (discrimination of p from π and K) and the measurement of its momentum to 10%; the momentum range is 400 - 850 MeV/c. Both these requirements are met by combining the following 3 measurements:

Pulse Height: Table 4 gives dE/dX values for the recoil protons in the various counter. Values range as high as 9x minimum ionizing. Pulse height discrimination will be used on all counters.

Time-of-flight is measured between counter C_1 and C_3 which span 10 to 15 feet. Time differences between protons of interest and elastic protons are given in Table 4.

Range Selection is achieved by two tapered aluminum absorbers; a thick absorber which determines the threshold momentum p_3 and a

thin absorber, used in conjunction with a veto counter behind it, which determines the momentum bite Δp_3 . Absorber thicknesses are given in Table 4.

Rejection rates of 99.5% for π 's and K's have been accomplished in this manner.

General Remarks;

Investigations³⁻⁶ of the missing-mass spectrum in collisions of the type (1) have hitherto been done mostly near 0° emission of the recoil particle whose missing-mass is measured. In contrast, we use the region of maximum angle ("Jacobian peak"), which has several advantages over the 0° region:

- The detectors are far outside the major cone of background spray which is typically $\pm 5^\circ$ (Lab); for comparison, the maximum angle in reaction (1) is 45° to 70° (Lab).
- The $d\Omega^{CM} \rightarrow d\Omega^{Lab}$ transformation has a sharp maximum at $\theta_3(\text{Max})$; thus even for isotropic CM angular distribution the number of events is at least an order of magnitude higher than at any other angle. The peripheral production of N^* 's enhances this number by a large factor, depending on the $d\sigma/dt$ dependence.
- At $\theta_3(\text{Max})$ the mass resolution is always better because of Condition (9).
- Since $\theta_3(\text{Max})$ is directly related to the missing-mass, the mass spectrum is given directly and immediately.

III. Experimental Setup for Options 1 and 2 (Extracted Proton Beams)

The experimental arrangement is shown in Fig. 5. We plan to use the extracted proton beam of 10^{10} or 10^{13} /pulse intensity at two momenta; 100 and 200 GeV/c to scan the mass bands from 4 to 7 GeV and 5 to 10 GeV respectively. The proton beam is incident on a "point" hydrogen target ($\sim \frac{1}{2}$ "") and the recoil protons are detected at the maximum angle of recoil $\theta_3(\text{Max})$ by counters C_1 to C_3 . A momentum bite Δp of 10% is achieved by means of two tapered absorbers (Fig. 5), the trigger logic being 12345.

The position of each event is recorded by one 100-element counter hodoscope (each element is $\frac{1}{4}$ " wide). This information, in conjunction with the point target, determines the recoil angle θ_3 .

The horizontal angular acceptance per one hodoscope element is $\Delta\theta = 1.4$ mr/element. The vertical angular acceptance of the spectrometer is 33 mr. The corresponding laboratory solid angle is

$$\Delta\Omega = 4.5 \times 10^{-5} \text{ ster/element.}$$

The mass-bite per setting of the spectrometer is 1.3 GeV and 1.8 GeV at incident momenta of 100 and 200 GeV/c respectively. The spectrometer will be moved between $\theta_{\text{Lab}} = 45^\circ$ and 70° in four steps for both incident momenta to cover the mass region 4 to 10 GeV with a mass resolution of ± 25 MeV or better.

IV. Experimental Setup for Option 3 (Gas Jet in Internal Beam)

The experimental apparatus for this option (Fig. 6) consists of a hydrogen gas jet in the internal beam during acceleration. The jet is viewed by a counter-range-telescope at fixed angle, the telescope being small enough to fit inside the 9 foot wide main tunnel. The recoil protons from the reaction $p+p \rightarrow p+MM$ are detected at a fixed momentum of $\sim 650 \text{ MeV}/c \pm 5\%$ and fixed angle of 55° (Lab). Under these conditions, during acceleration of the internal beam from $20 \text{ GeV}/c$ to $500 \text{ GeV}/c$, the spectrometer selects Jacobian peaks corresponding to missing-masses from 3 GeV to 13 GeV respectively (See Fig. 3). The momentum bite Δp of 10% is achieved by means of two absorbers (Fig. 6), the trigger logic being 12345. The time of each event is recorded and since time is proportional to the proton energy during acceleration, the number of events versus time gives the missing-mass spectrum directly.

The protons of interest are selected by means of range, time-of-flight ($\beta = 0.6$), and pulse height. Events are recorded in a 1000 channel pulse height analyzer. No hodoscopes, magnets, wire planes or computers are used. The expected mass resolution is $\pm 10 \text{ MeV}$ and $\pm 40 \text{ MeV}$ at missing masses of 3 GeV and 13 GeV respectively. The resolution as a function of missing mass is given in Fig. 4 together with the expected separation between successive peaks. The variation of the recoil momentum p_3 from $614 \text{ MeV}/c$ at $p_1 = 20 \text{ GeV}/c$ to $655 \text{ MeV}/c$ at $p_1 = 500 \text{ GeV}/c$ is smaller than the momentum bite Δp of 10% and does not contribute to the mass resolution (See Eq. 9).

V. Counting Rates and Statistical "Sensitivity" to Detect Peaks

To estimate the counting rate we need the absolute values of the double-differential inelastic pp cross-section $d\sigma/(dt dM)$. We assume the general behavior

$$\frac{d^2\sigma}{dt dM} [pp \rightarrow p + (\Delta M = 1 \text{ BeV})] = A e^{bt} \frac{\text{mb}}{(\text{GeV}/c)^2 \text{GeV}} \quad (11)$$

Our compilation of the existing data up to 30 GeV on $pp \rightarrow p + MM$ indicates that the inelastic processes at medium t values (0.2 - .6) can be approximately described either by $A = 50$, $b = 5$, or by $A = 200$, $b = 8$. The first set of values is compatible with the theoretical calculation of Satz⁸ who predicts the asymptotic value of b for two-body (resonant + non-resonant) production: as $M \rightarrow \infty$, $b \rightarrow 5$. For an average recoil momentum of $p_3 = 0.6 \text{ GeV}/c$, $t = 0.36$, $A = 50$, $b = 5$ gives

$$\frac{d^2\sigma}{dt dM} = 8 \times 10^{-27} \frac{\text{cm}^2}{(\text{GeV}/c)^2 \text{GeV}} \quad (12)$$

The counting rate (resonant plus non-resonant) is given by

$$\text{Rate} = \left(\frac{d^2\sigma}{dt dM}\right) (N_P N_H) (\Delta t \Delta M \frac{\Delta\phi}{2\pi}) \quad (13)$$

where the quantities are given in Table 1.

Equation (13) becomes

$$\text{Rate (Opt. 1,2)} \approx 6 \times 10^{-30} N_P N_H / \text{pulse (over 100 hod.el.)} \quad (14)$$

and

$$\text{Rate (Opt. 3)} \approx 6 \times 10^{-32} N_P N_H / \text{pulse (10}^5 \text{ traversals)} \quad (15)$$

Let us call statistical significance \underline{s} the total statistical error in % over the width equal to the full-width resolution, $\Gamma \approx 50 \text{ MeV}$.

This is typically 3 bins in our case, so that, for one day of running

$$s = \frac{580}{\sqrt{\text{Rate/day}}} \% \quad (16)$$

We set the criterion that the peak has to have at least 5 standard deviations to be believed real. We define by S the sensitivity of the experiment to detect a peak equal to or narrower than the resolution as 5 times s:

$$\text{Sensitivity } S = 5s = \frac{16}{\sqrt{\text{Rate/pulse}}} \% \quad (17)$$

where we assumed 30,000 pulses/day. For example, $S = 1\%$ means: "a peak with signal:background ratio 1/100 can be detected with 5 standard deviations in 1 day of running."

VI. Experimental Mass Resolution

The main contribution to the mass resolution Γ_{res} comes from the derivative $\partial M/\partial \theta_3$ and the uncertainty $\Delta \theta_3$ in the measurement of θ_3 . Since the recoil momenta p_3 are low (400 to 850 MeV/c), the limiting factor in the measurement is multiple Coulomb scattering in the material between target center and the hodoscope elements. The mass resolutions for options 1, 2 and 3 are given in Tables 2 and 3 and Fig. 4.

VII. Comparison of the Options

A comparative survey of all options on this Proposal are given in Table 5.

- It is evident that Option 3 is superior in all features.
- If the beam becomes 5×10^{13} and the H_2 jet 10^{17} atoms/cm³, Option 1A becomes attractive.
- Option 1B can be used for the search of 1% peaks with the presently planned parameters at a very early stage.
- Option 2 is sufficiently sensitive already with the present parameters, but it requires opening of Area 2.
- All options offer good resolution, satisfying conditions (5-6).

References

1. H. Harari, Resonances - Theory; Rapporteurs Talk at the 1968 Vienna Conference, page 215.
2. H. Goldberg, Phys. Rev. Letters 21, 778 (1968).
3. B. Maglič and G. Costa, Phys. Rev. Letters 18, 185 (1965).
4. C. M. Ankenbrandt, A. R. Clyde, Bruce Cork, D. Keefe, L. T. Kerth, Nuovo Cim. 35 (1965), 1052.
5. G. Cocconi, E. Lillethun, J. P. Scanlon, C. A. Stahlbrandt, C. C. Ting, J. Walters and A. M. Wetherell, Phys. Letters 8, (1964), 135.
6. I. M. Blair, A. E. Taylor, W. S. Chapman, P. I. P. Kalmus, J. Lett, M. C. Miller, D. B. Scott, H. J. Sherman, A. Astbury and T. G. Walker, Phys. Rev. Letters 17 (1966), 789.
7. E. W. Anderson, E. J. Bleser, G. B. Collins, T. Fujii, J. Menes, F. Turkot, R. A. Carrigan, Jr., R. M. Edelman, N. C. Hien, T. J. McMahon and I. Nadelhaft, Phys. Rev. Letters 16 (1966), 355.
8. H. Satz: "On the Mass Dependence of Momentum Transfer Distributions", Preprint TH.1175-CERN, 4 June 1970.

TABLE 1

Counting Rate Parameters, Rates and Sensitivity to Detect Peak (See Formulae 12-17).

	Option 1		Option 2	Option 3
	A(H ₂ jet)	B(CH ₂)		
N_p = no. of inc. protons/pulse/cm ²	10 ¹³	10 ¹³	10 ¹⁰	10 ¹⁸
N_H = no. of target H atoms/cm ²	5x10 ¹⁶	2x10 ¹⁹	3.6x10 ²²	5x10 ¹⁶
Δt = mom. transfer acceptance in (GeV/c) ²	0.16	0.16	0.16	0.16
ΔM = typical mass bite in GeV	1.8	1.8	1.8	1.3x10 ⁻²
$\Delta\phi$ = vert.ang acceptance of Hodoscope in mr	33	33	33	50
$\Delta\phi/2\pi$ =	5x10 ⁻³	5x10 ⁻³	5x10 ⁻³	8x10 ⁻³
R=Rate=counts/machine pulse (res+nonres)	3	1500*	2000	30,000 [†]
R_D =counts/day*** (res + nonres)	100,000	5x10 ⁷ *	6x10 ⁷	10 ⁹
s = significance of peak = (Rate) ^{-1/2} /50 MeV mass band/day	2%	0.4%***	0.1%	0.02%
S = sensitivity to detect peak in day	10%	2%	0.5%	0.10%

*Contribution from H₂ only. Carbon background could be 10 times larger.

**Corrected for the carbon background.

***30,000 pulses per day assumed

[†]over the mass band ≈10 GeV

TABLE 2

Mass Resolution Options 1 and 2
(External Beam, H₂ gas jet and H₂ liquid targets)

	Recoil Momentum p ₃ (MeV/c)	p ₁ = 100 GeV/c, ∂M/∂θ ₃ = 9 MeV/mr		p ₁ = 200 GeV/c, ∂M/∂θ ₃ = 13 MeV/mr	
		Missing-mass (GeV)	Mass Resolution (MeV)	Missing Mass (GeV)	Mass Resolution (GeV)
Option 1 H ₂ gas jet 10 ¹³ Beam External	400	4.0	±24	5.6	±34
	600	5.5	±15	7.7	±21
	850	7.0	±12	10.0	±17
Option 2 Liquid H ₂ 10 ¹⁰ Beam External	400	4.0	±33	5.6	±47
	600	5.5	±18	7.7	±26
	850	4.0	±14	10.0	±20

TABLE 3

Mass Resolution Option 3

(Variable incident momentum, i.e. internal beam)

$P_3 = 650 \text{ MeV/c}$, Angular Resolution = $\pm 2.0 \text{ mr}$			
Incident Momentum (GeV/c)	Missing Mass (GeV)	$\partial M / \partial \theta_3$ (MeV/mr)	Mass Resolution (MeV)
20	2.7	3.7	± 8
50	4.2	6.3	± 13
100	5.9	9.0	± 18
200	8.3	13	± 26
500	13.0	20	± 40

TABLE 4

Pulse Height, Time-of-Flight and Absorber Thickness

Recoil Momentum P_3 (MeV/c)	Pulse Height in $C_{1,2,3}$ (x Min.Ion.)	Pulse Height in $C_{4,5}$ (x Min.Ion.)	ToF diff./10ft. inelastic to elastic (nsec.)	1st Absorber (in. of Al)	2nd Absorber (in. of Al)
400	4.2	9.0	15	0.7	0.2
600	2.4	5.2	9	3.7	0.7
850	1.7	3.5	6	9.5	1.6

TABLE 5

Comparison of Options

FEATURES:	Option 1A 10^{13} extracted p's	Option 1B 10^{13} extracted p's	Option 2 10^{10} extracted p's	Option 3 internal beam
1. Simplicity of setup	gas jet target, 100 el. hodoscope, 5 trigger counters	CH ₂ film target, 100 el. hodoscope, 5 trigger counters	Liquid H targets, 100 el. hodoscope, 5 trigger counters	Gas jet target 5 counter telescope
2. Simplicity of operation	change angle, timing and range between runs	change angle, timing and range between runs	change angle, timing and range between runs	No change (fixed parameters for all masses)
3. Resolution (MeV)	± 12 to ± 24	± 12 to ± 24	± 14 to ± 33	± 13 to ± 26
4. Events per 1.8 GeV per day (res + nonres)	10^5	5×10^7	6×10^7	10^9
5. Peak significance per day (16)	2%	0.4%	0.1%	0.02%
6. Sensitivity $S=5s$ to see peak/day(17)	10%	2%	0.5%	0.1%
7a. Running time to scan mass band 4-10 GeV to get $S=1\%$	300 days	12 days	1 day	24 min..
7b. Running time to scan mass band 4-10 GeV to get $S=0.1\%$	3×10^4 days	10^3 days	10^2 days	2 days
8. Expansion of Exp. area needed	YES	YES	NO	NO
9. Can be done as soon as..	...beam is extracted	... beam is extracted	...Exp. area 2 is open	...Beam is accelerated

$$p_1 + p_2 \rightarrow p_3 + MM$$

$$P_1 = 200 \text{ GeV}/c$$

OPTIONS 1 and 2

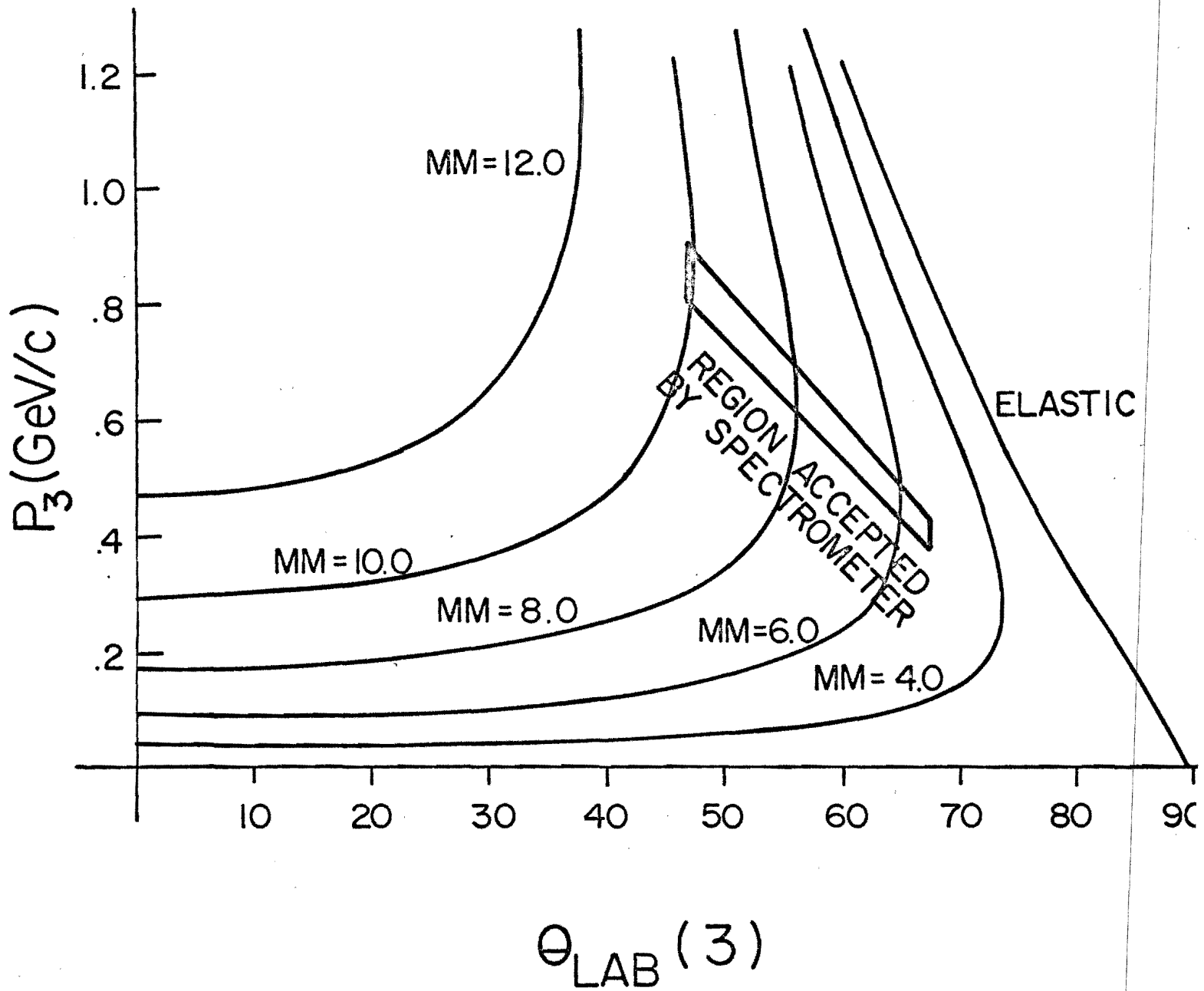

Fig. 1.

$$p_1 + p_2 \rightarrow p_3 + MM$$

$$P_1 = 100 \text{ GeV}/c$$

OPTIONS 1 and 2

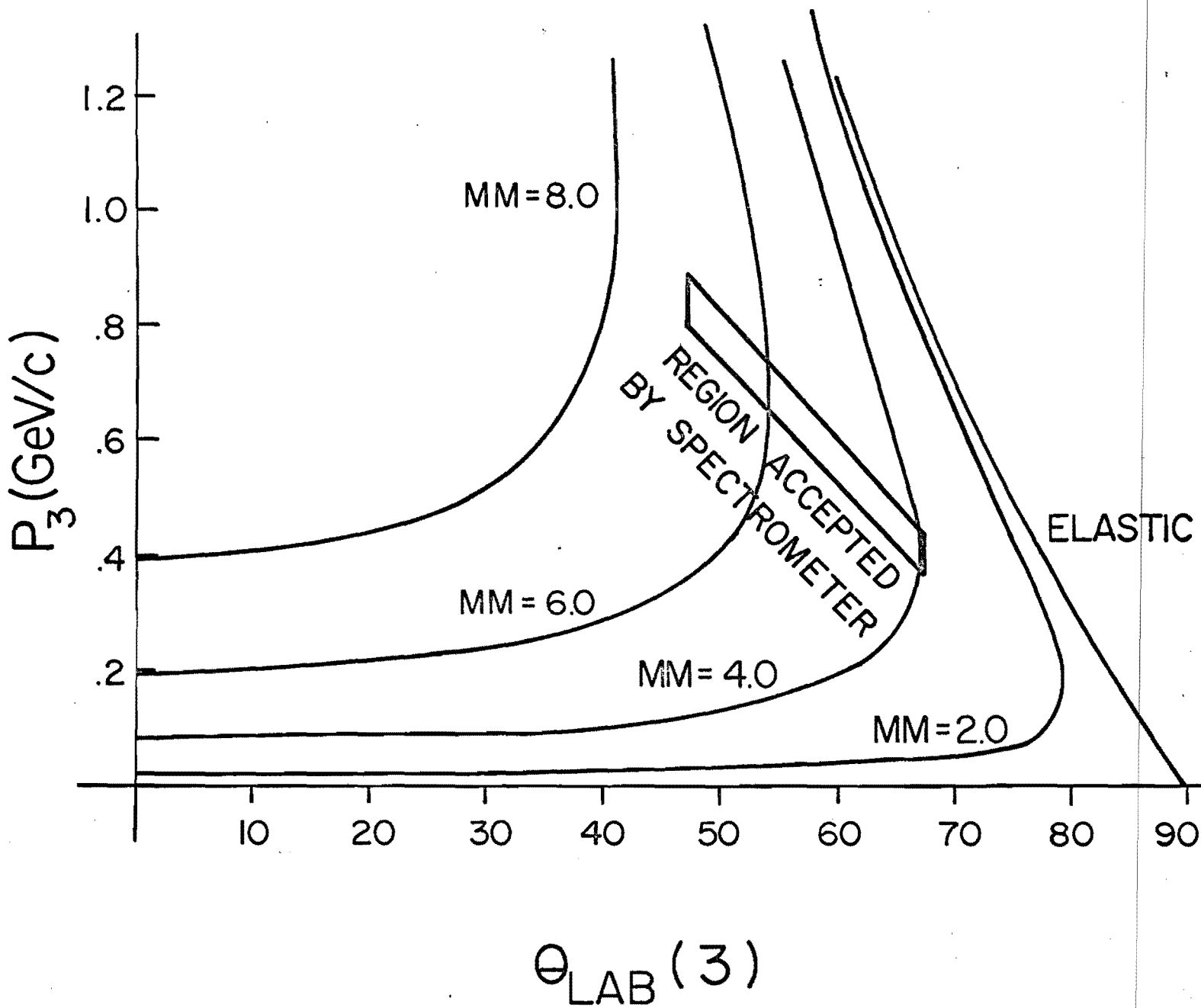

Fig. 2.

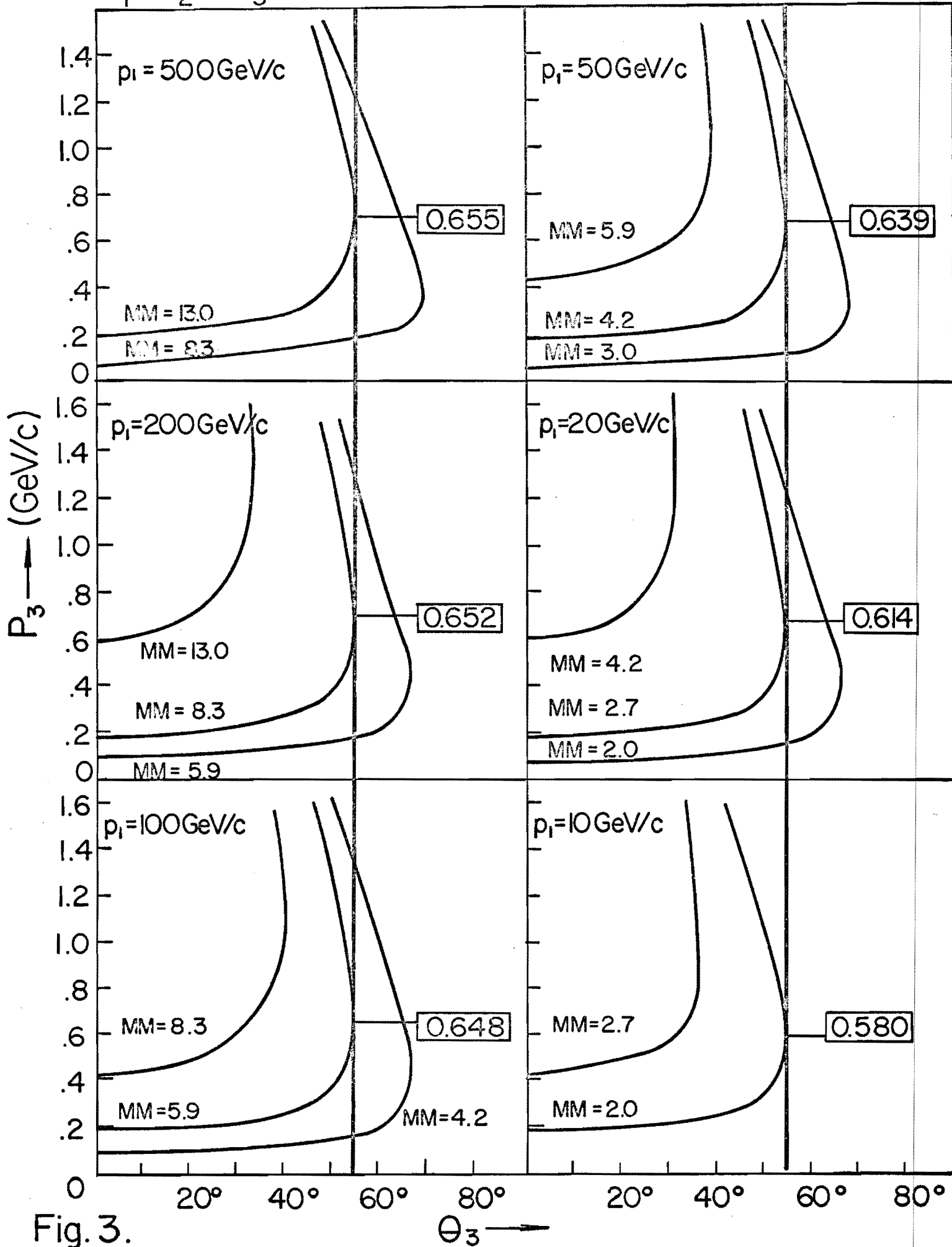

Fig. 3.

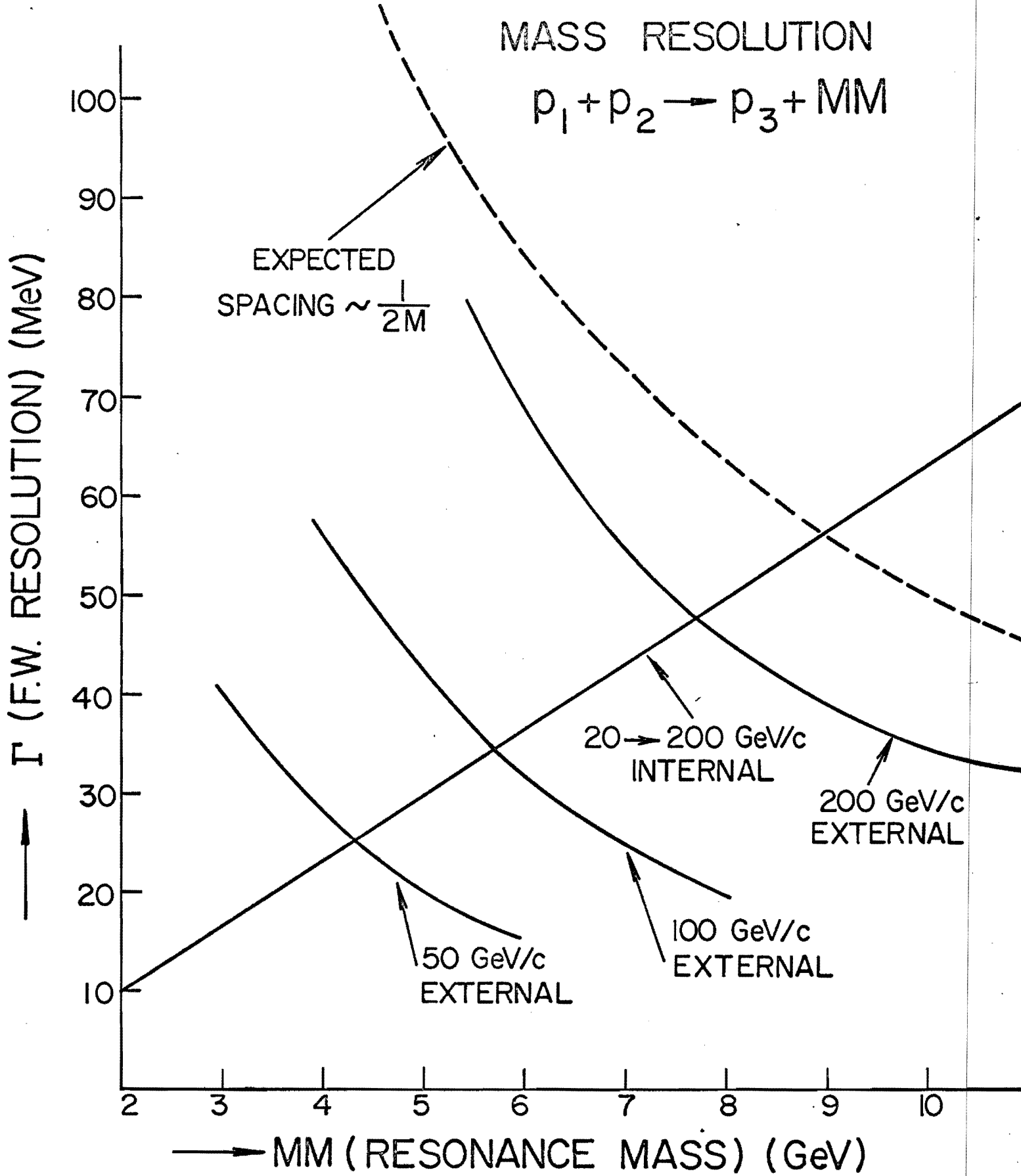

Fig. 4.

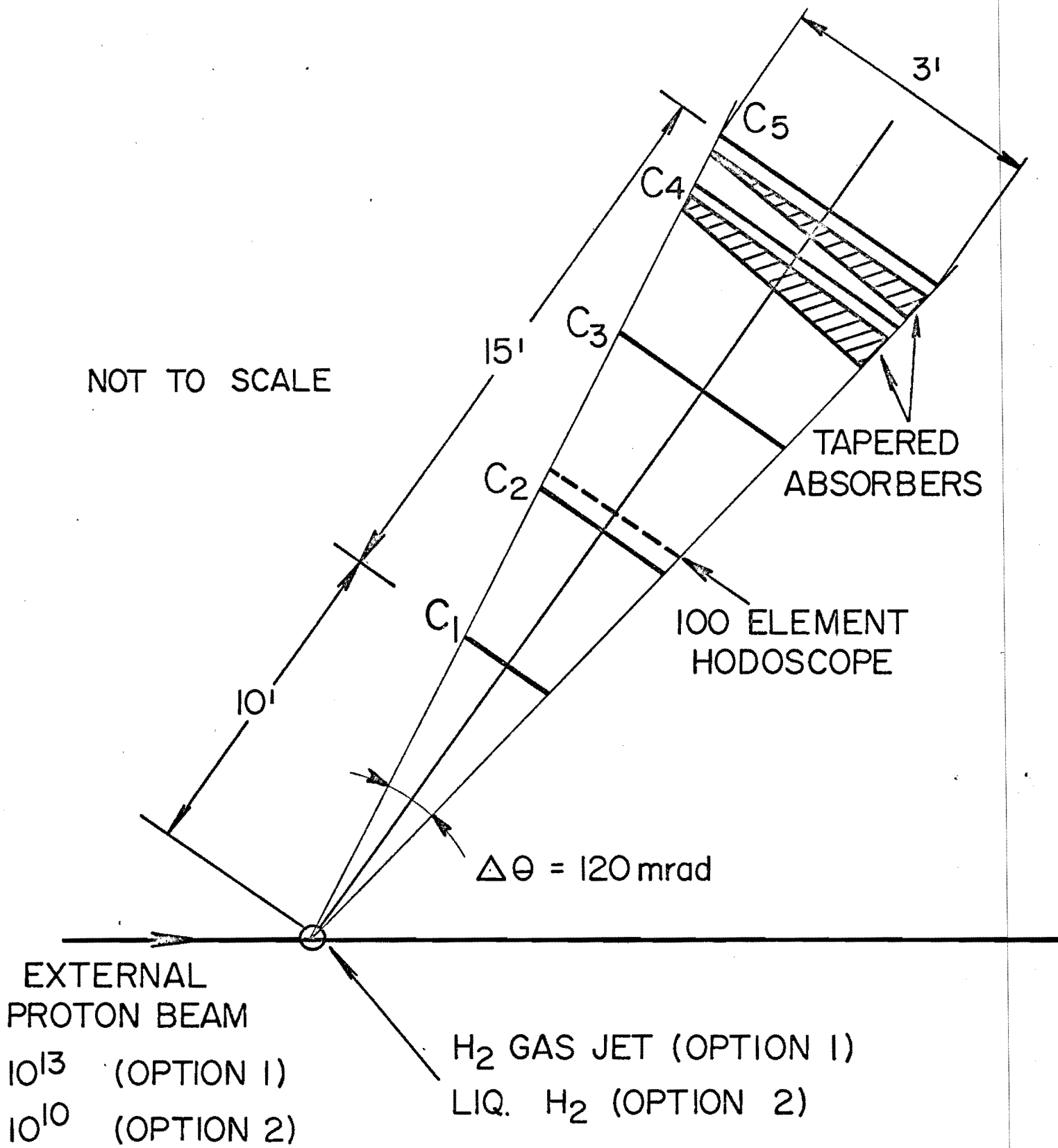

Fig. 5.

OPTION 3. EXPERIMENT INSIDE MAIN RING

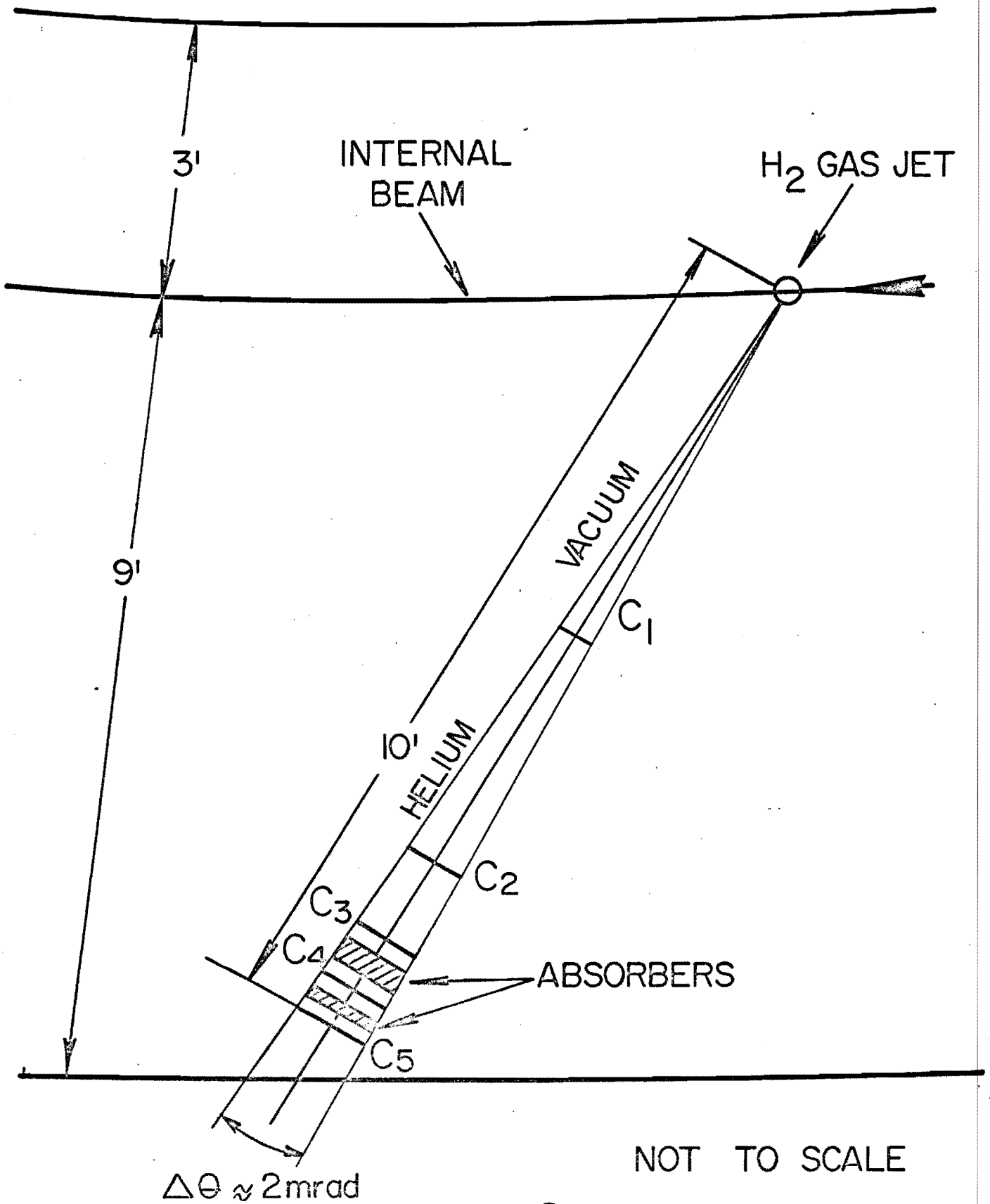

Fig. 6.

November 18, 1970

Appendix to Proposal #67 containing:

- 1) Results from PPA using identical apparatus as proposed for NAL experiment #67
- 2) Monte-Carlo results for proposed NAL experiment #67.

Abstract Submitted
for the Austin Meeting of
The American Physical Society
November 5-7, 1970

Physical Review
Analytic Subject
Index Number 63.6

Bulletin Subject Heading
in which paper should be placed
Baryon Resonances (Experiment)

Measurement of N^* Widths with New Missing-Mass Spectrometer.[†] F. SANNES, W. E. ELLIS, J. NOREM, M. SILVERMAN, B. MAGLIC, J. ABATE, D. BUNCE and D. HARTMAN, Rutgers University. -- The missing-mass spectrum of protons from the reaction $p + p \rightarrow p + MM$ is measured at PPA in the mass region from 1200 to 1800 MeV with a resolution of ± 5 MeV and statistics of 10^6 events per 2 MeV bin. The magnet-less spectrometer consists of only a "point" liquid hydrogen target (2 cm) and one 60-element hodoscope measuring recoil angle. The "Jacobian peak" protons are selected by means of range and time-of-flight. The hodoscope angular distribution of these protons gives the N^* mass spectrum directly, displayed on a pulse-height analyser. Strong $\Delta(1236)$, $N^*(1520)$ and $N^*(1690)$ peaks are observed. The preliminary values for the widths of the three peaks are 102 ± 12 , 78 ± 5 and 110 ± 20 MeV respectively.

[†]Work supported in part by the National Science Foundation.

FIGURE CAPTIONS

- Figure 1 Missing-mass spectrometer experimental setup. The extracted proton beam (2×10^{11} /sec) of variable energy 2.7 - 3 GeV comes from the left; by monitoring the extraction time the proton energy is known for each trigger. The trigger time is recorded in one dimension of a 2-dimensional pulse-height analyser, the other dimension being the hodoscope element (angle of the recoil proton). The timing counters are from 1/32" to 1/4" thick with isochronous light pipes. Each hodoscope element is 1/2" wide and 4" high, subtending 3 mr.
- Figure 2 Kinematics: Laboratory proton angle versus laboratory proton momentum. The boxes illustrate the spectrometer acceptance at one setting.
- Figure 3 Missing-mass spectrum in the region of $\Delta(1236)$: Rate versus Mass (GeV) in 2 MeV steps.
- Figure 4 Missing-mass spectrum in the region of $N^*(1520)$: Rate versus Mass (GeV) in 2 MeV step. Note suppressed zero on vertical scale.

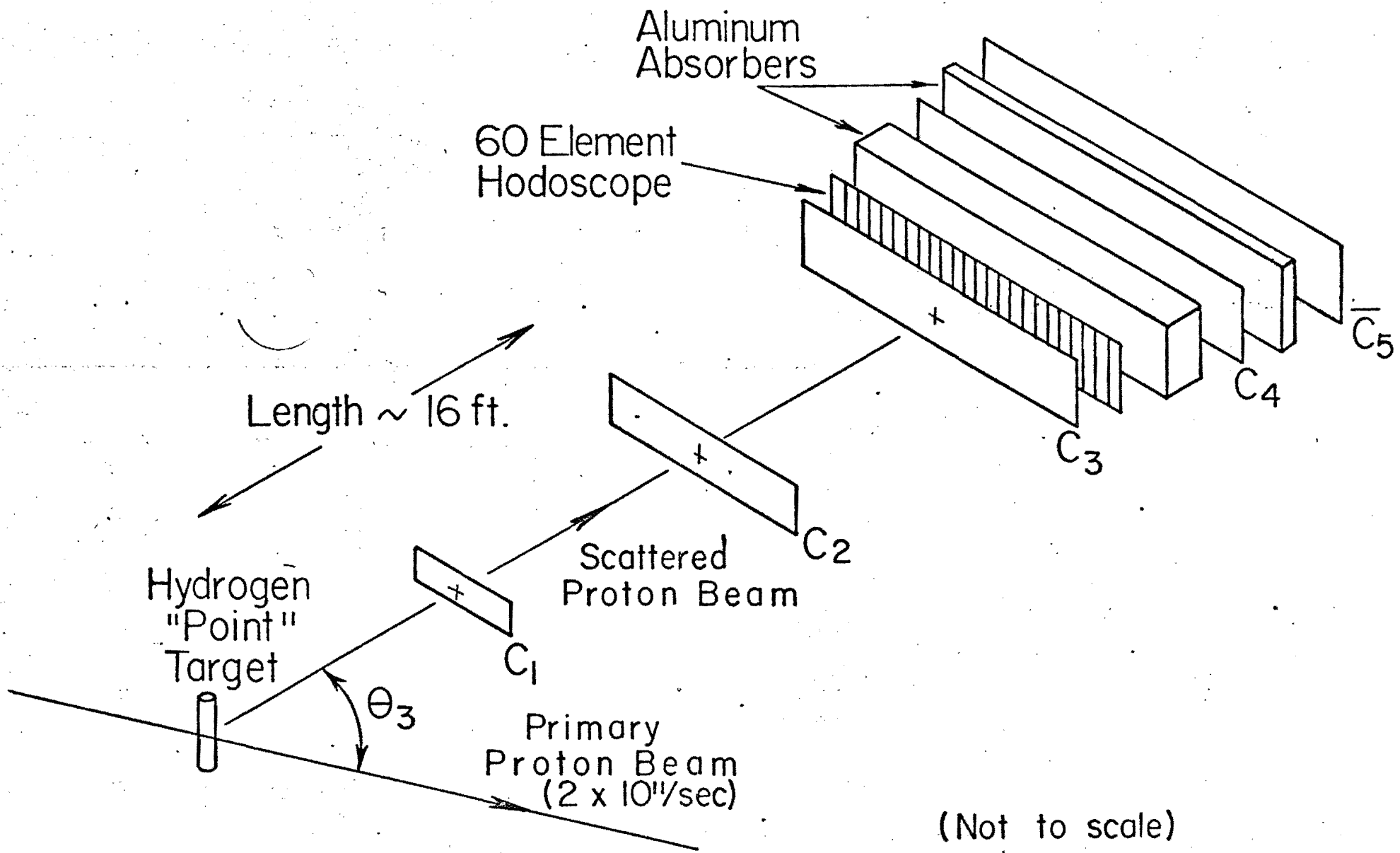

FIGURE 1

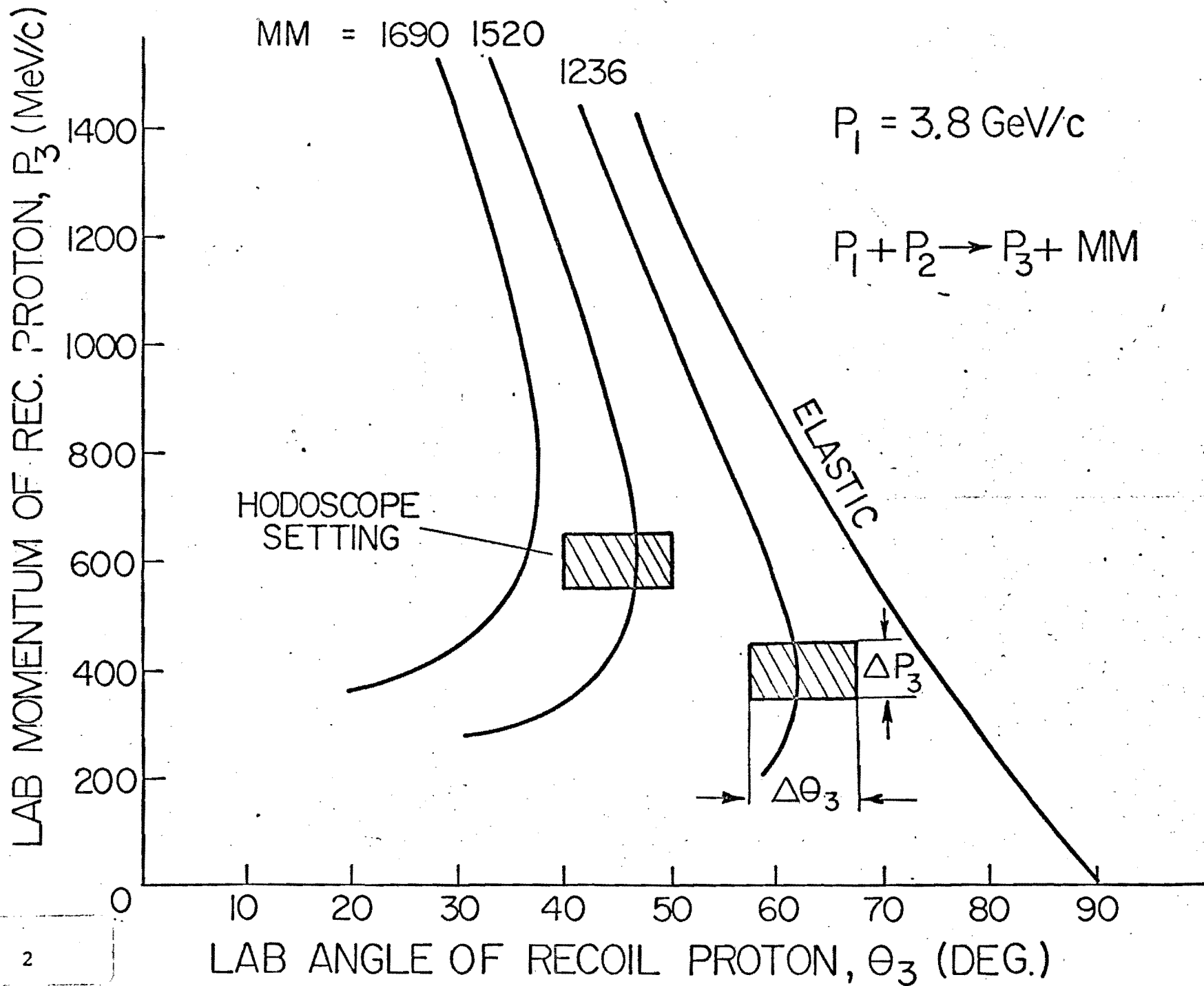

FIGURE 2

RUTGERS

RUNS: AUGUST 1970

$$p + p \rightarrow p + MM$$

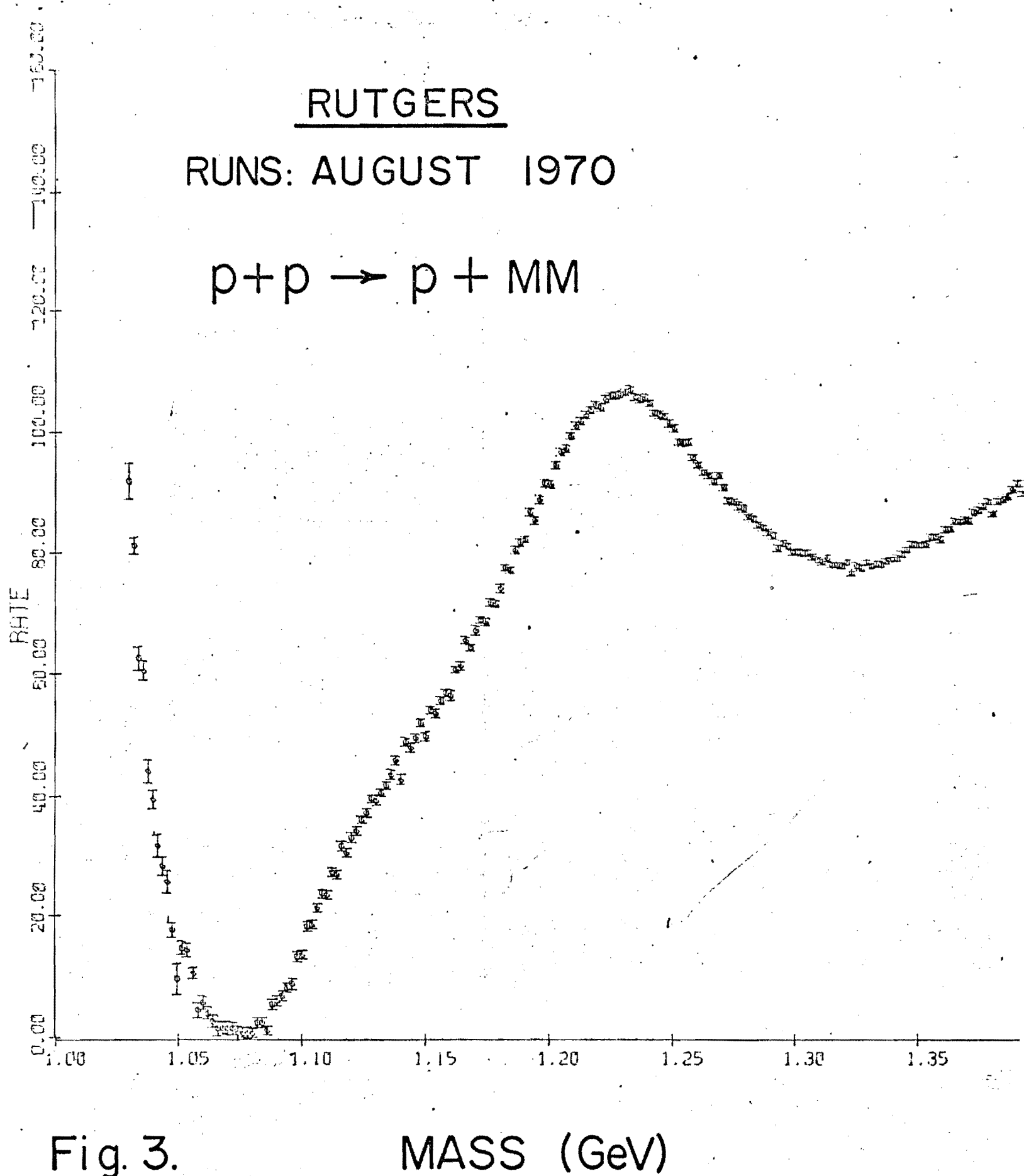

Fig. 3.

MASS (GeV)

RUNS 32091-33164 600 MEV/C

RUTGERS

RUNS: AUGUST 1970

$p + p \rightarrow p + MM$

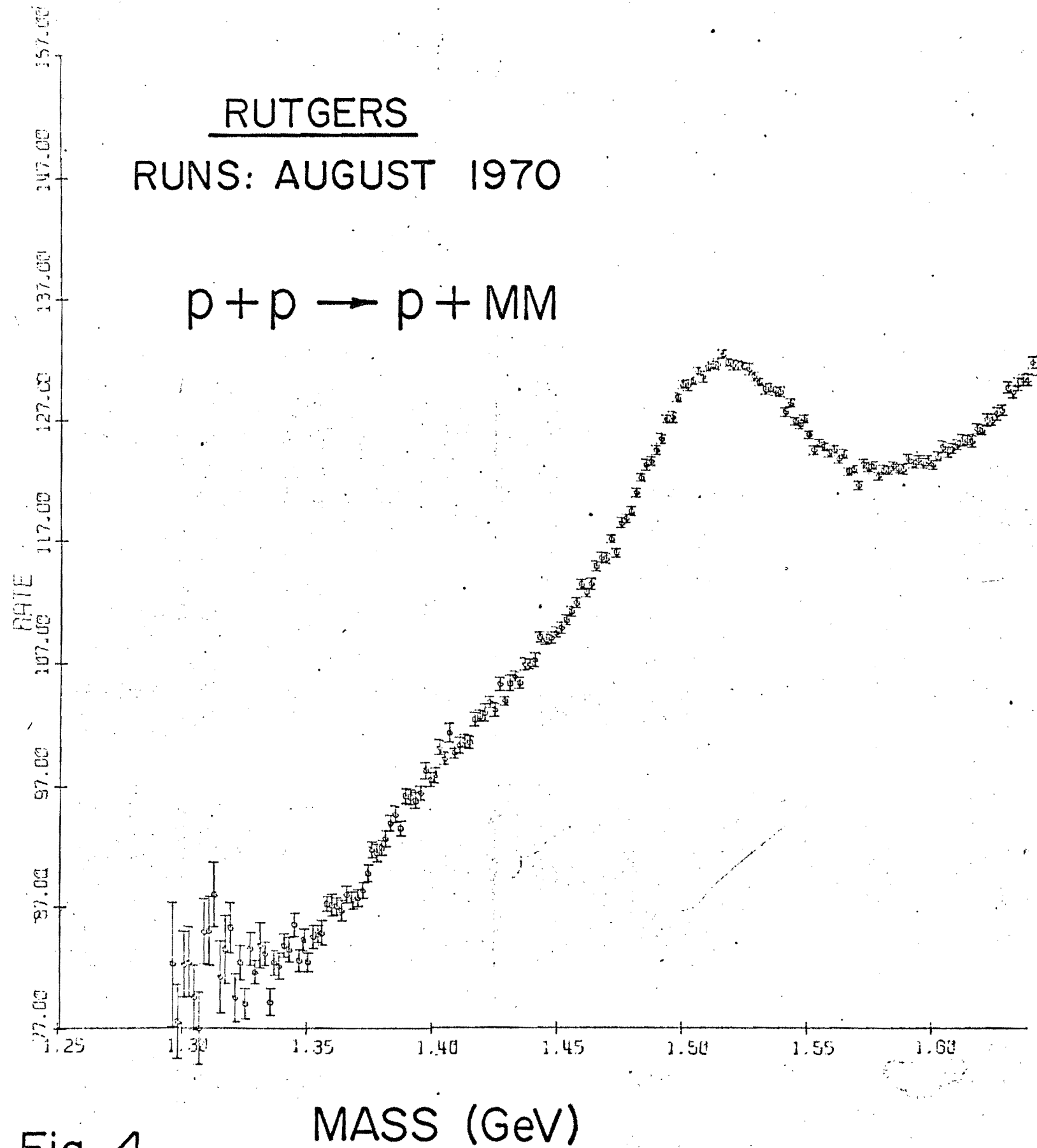

Fig. 4.

```

XX*****XX*****XX*****XX*****XX*****XX*****XX*****XX*****XX*****XX
2500X   THIS MONTE-CARLO OUTPUT GIVES AN IDEA
      OF THE EXPECTED SIGNAL-TO-BACK. RATIO ASSUMING RESO-
      NANCE CROSS-SECT  $\sigma_{RES} = 0.1 mb$  AND 3 N* MASSES AT:
      5920, 6000 & 6080 MEV WITH PHYSICAL WIDTHS  $\Gamma = 40$  MEV.
      THE NON-RESONANT BACKGROUND LEVEL WAS CALCULATED FROM
      OUR EMPIRICAL FORMULA FOR  $d^2/dp_{\perp}dp_{||}$  AND RANDOMLY
      GENERATED.

```

NO. OF PROTONS PER ELEMENT

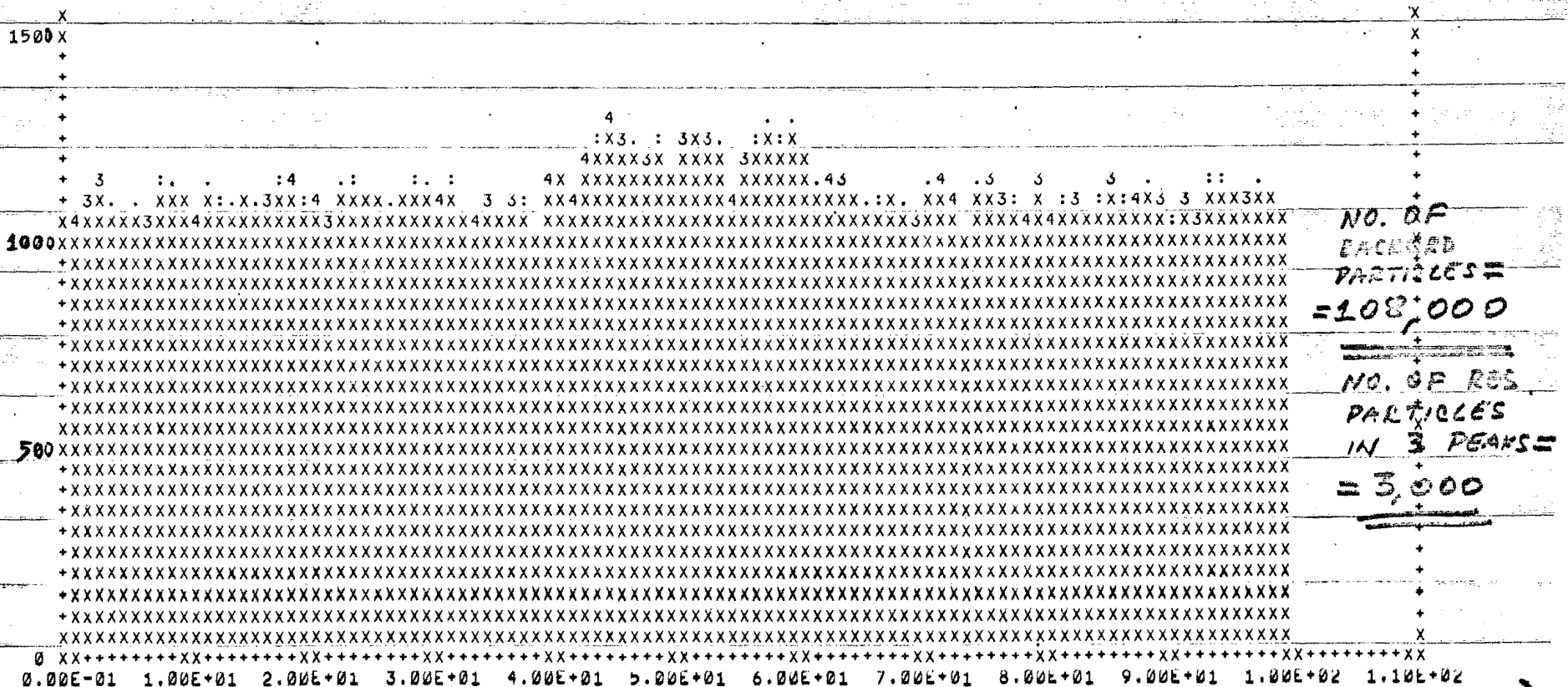

HODOSCOPE DISTRIBUTION (100 ELEMENTS, 12.6 MeV-per-ELEMENT)

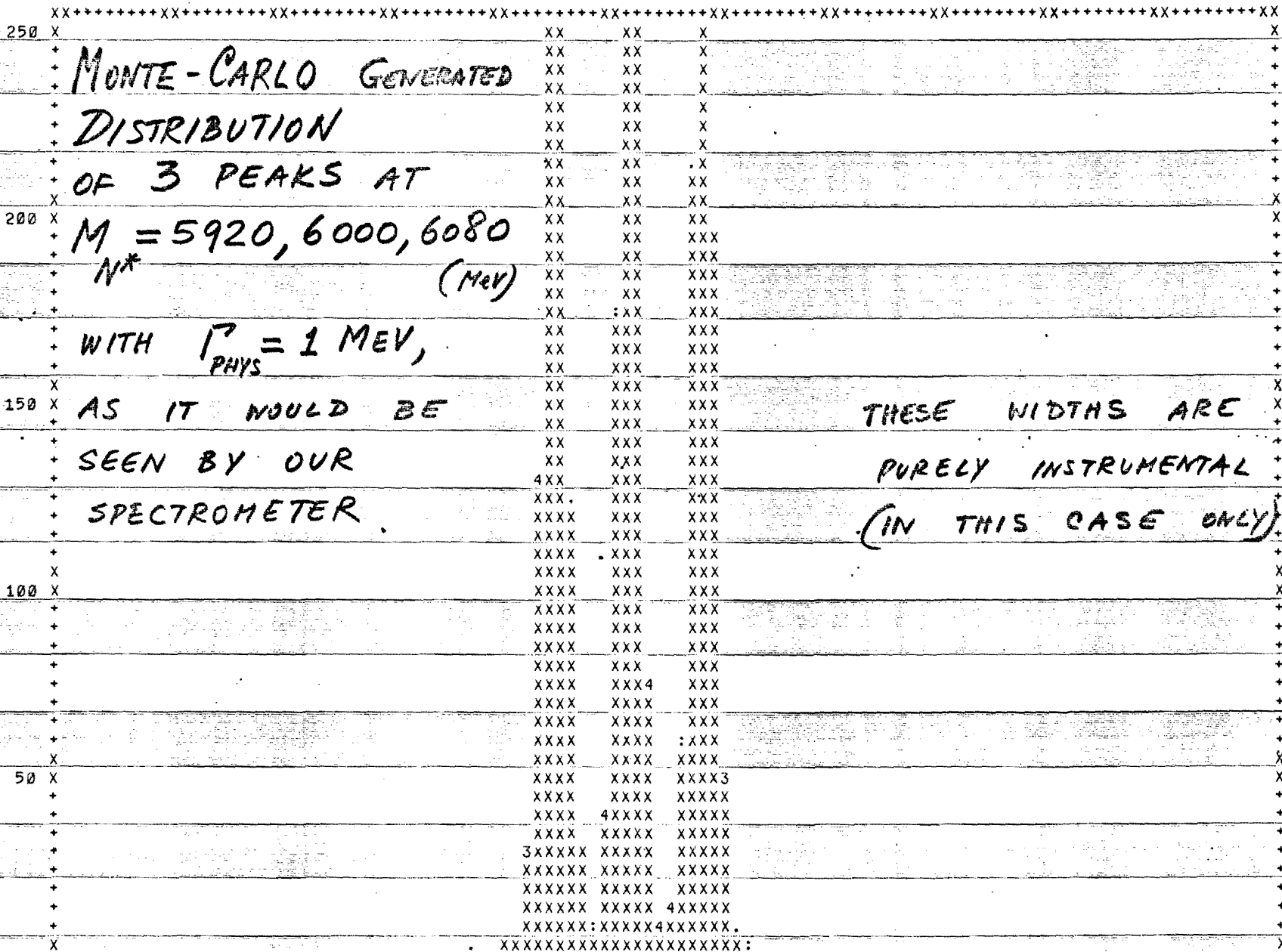

NO. OF EVENTS PER ELEMENT

MOSCOPPE DISTRIBUTION ABOVE BACKGROUND (1 ELEM = 12.6 MEV IN MASS)

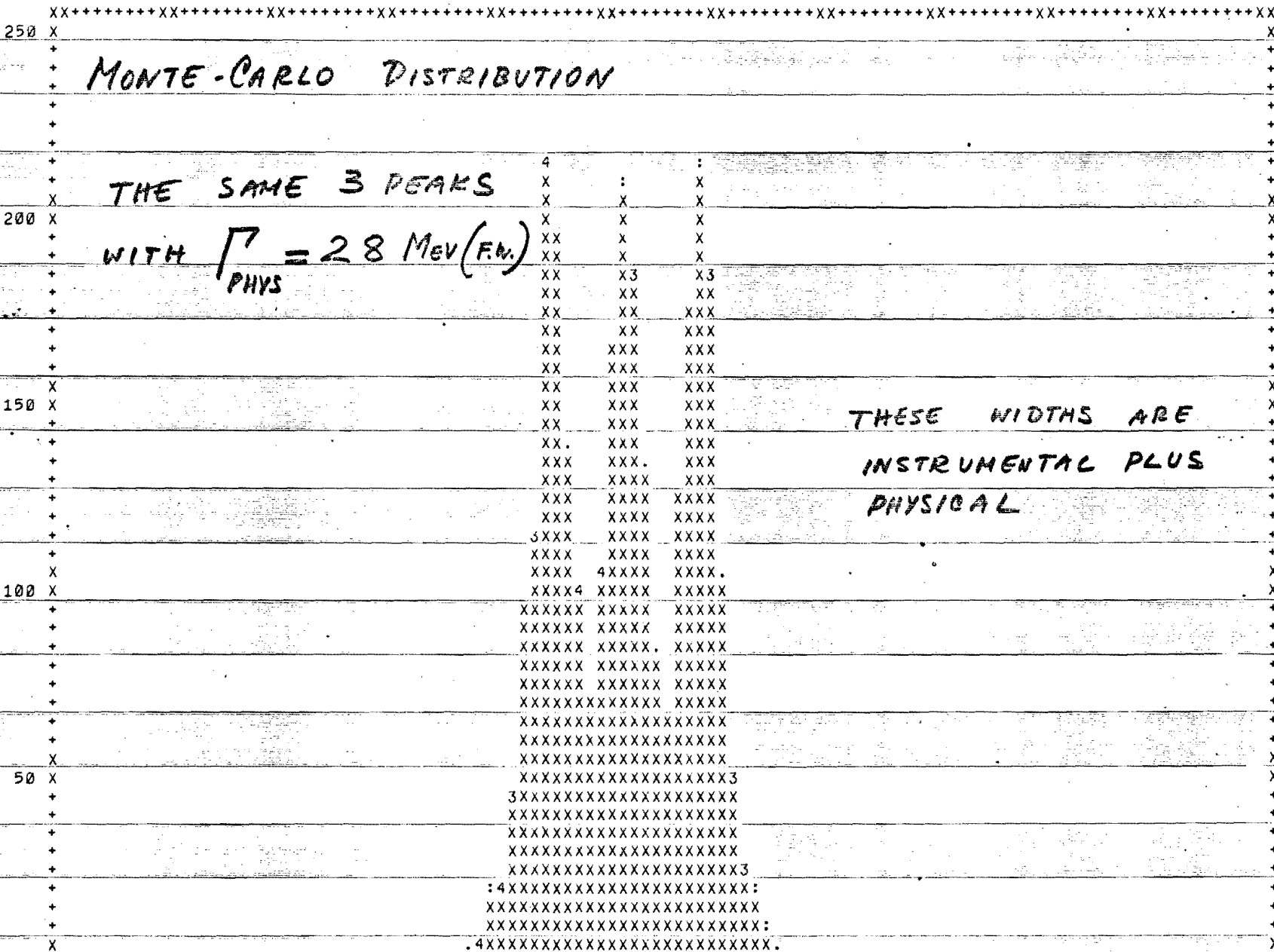

MONTE-CARLO DISTRIBUTION

THE SAME 3 PEAKS
WITH $\Gamma = 28$ MeV (F.W.)
PHYS

THESE WIDTHS ARE
INSTRUMENTAL PLUS
PHYSICAL

NO. OF EVENTS PER ELEMENT

0.00E+01 1.00E+01 2.00E+01 3.00E+01 4.00E+01 5.00E+01 6.00E+01 7.00E+01 8.00E+01 9.00E+01 1.00E+02 1.10E+02

HODOSCOPE DISTRIBUTION ABOVE BACKGROUND

NO. OF EVENTS PER ELEMENT

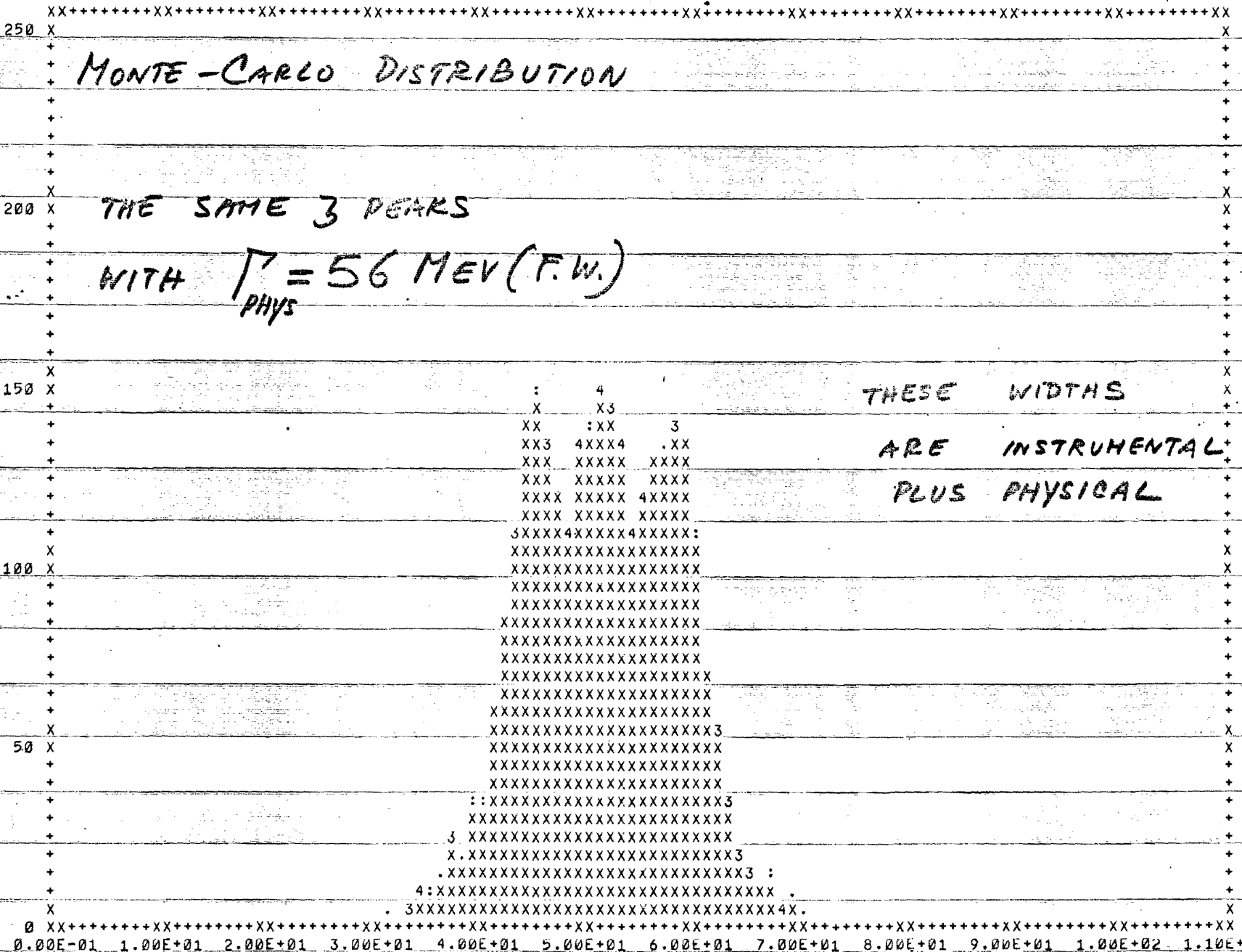

HODOSCOPE DISTRIBUTION ABOVE BACKGROUND

TOTAL WEIGHT OF EVENTS PLOTTED = 2822.0 2822 AVG. = 51.1960 WIDTH = 6.8083
 DATE: 11/17/70 TIME: 23:03:53 RUNT: 00:16:07 RUNNING TIME SINCE LAST CALL = 963.550 SEC. TIME/EVENT = 0.46178

RUNS 34061-34144 400 MEV/C

34061 - 34144

400 MeV/c

PPA RESULTS

SEPTEMBER 1970

RATE

0.00 20.00 40.00 50.00 60.00 80.00 100.00 120.00 140.00 160.00

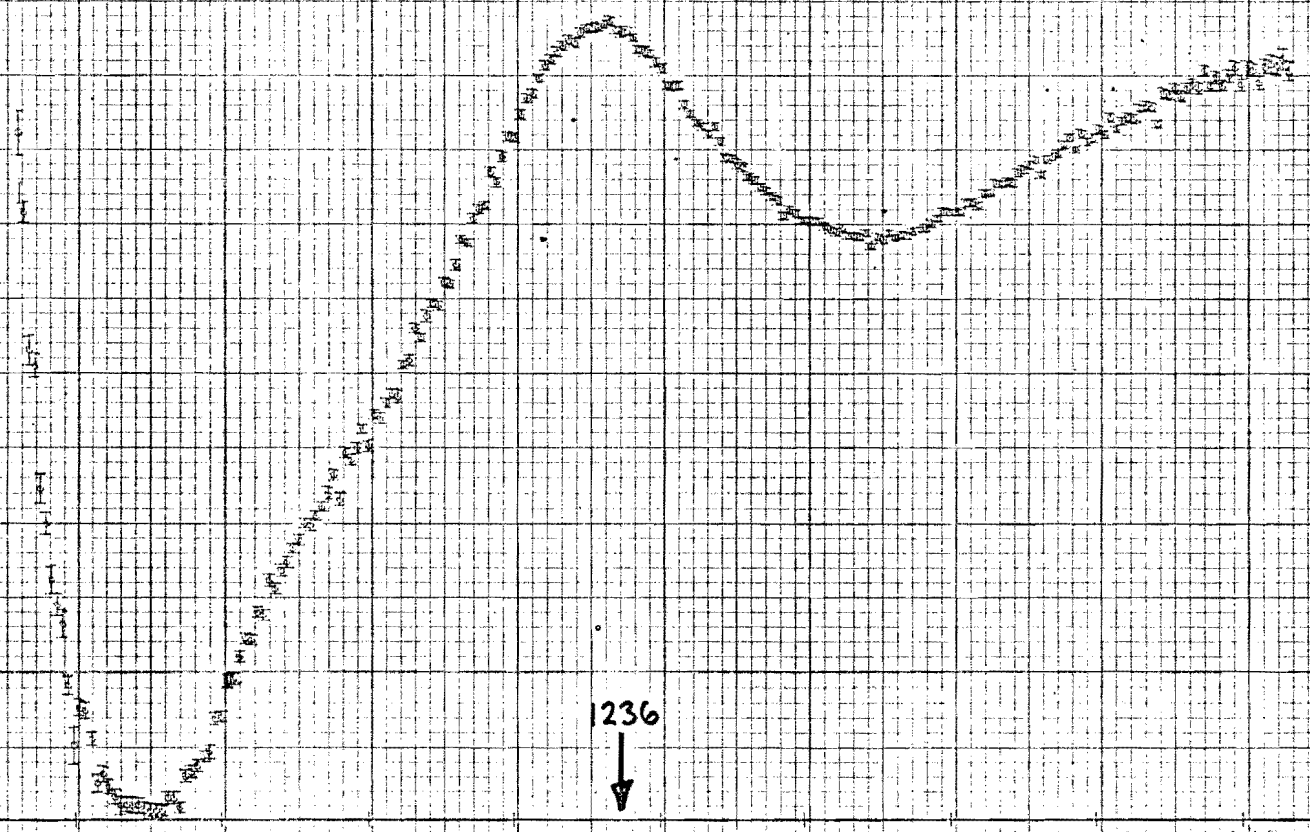

1236



MASS →

MASS

32031 - 32054, 32091 - 32104 600 MeV/c

PPA RESULTS SEPTEMBER 1970

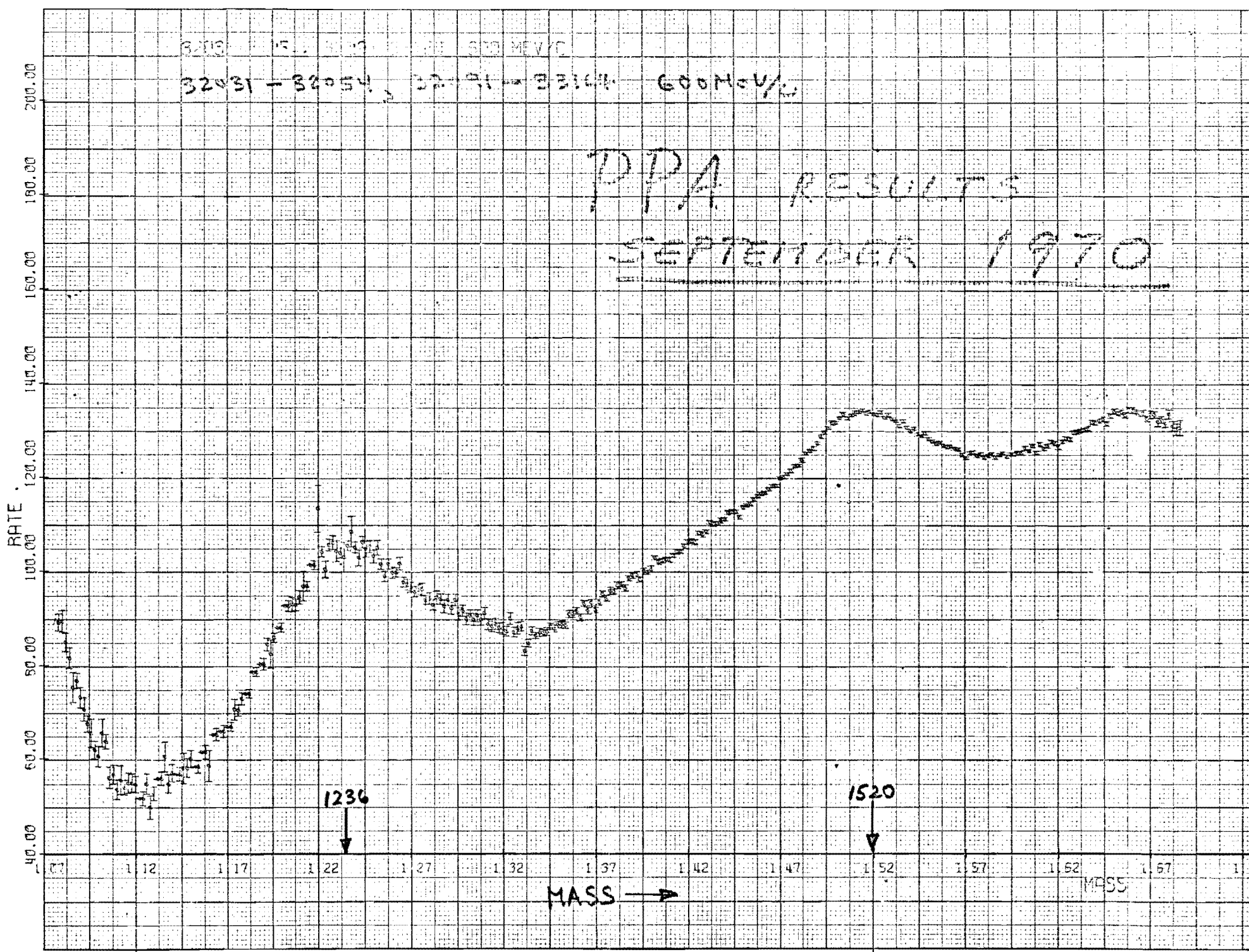

Addendum

to

Proposal #67 to National Accelerator Laboratory

Rutgers - The State University of New Jersey

(Search for Baryon Resonances up to 10 GeV Mass
Produced in $p + p \rightarrow p + MM$ with a Resolution of ± 25 MeV)

Contents: a) Description of Monte Carlo Program
b) Results of Monte Carlo Program
c) Revised Table 5 ('Comparison of
Option')

The Rutgers group has developed a Monte Carlo program to investigate the sensitivity of our apparatus to expected resonances in the reaction $p+p \rightarrow p + \text{Missing Mass}$. Working backwards from reasonable assumed properties of resonances and of background, experimental resolution was folded in to see what kind of experimental data can realistically be expected. By using physical parameters corresponding to our apparatus we have shown that the proposed experiment could indeed provide a meaningful set of results and conclusions. Because of the simplicity of the experimental apparatus it has been possible to check analytically the results of the Monte Carlo program.

The essential 'ingredients' of the program are as follows:

I. Experimental apparatus

This is discussed in detail in our proposal and only those aspects relevant to the Monte Carlo Calculation are mentioned here.

Effects considered are:

- 1) Multiple scattering along spectrometer and in target
- 2) $\frac{dE}{dx}$ losses along spectrometer
- 3) Nuclear scattering in counters, absorbers and target cell walls
- 4) Finite target volume
- 5) Finite beam size
- 6) Finite size of hodoscope elements

The spectrometer consisted of the following elements:

Element	Material	Thickness (inches)	Distance from target (inches)
Target	H ₂	.2	_____
Target cell wall	CH	0.006	0.2
C1	CH	0.036	120
C2	CH	0.25	179
Hodoscope	CH	0.25	180
C3	CH	0.25	240
1 st absorber	Al	variable	246
C4	CH	0.25	260
2 nd absorber	Al	1.0	272
C5	CH	0.25	284

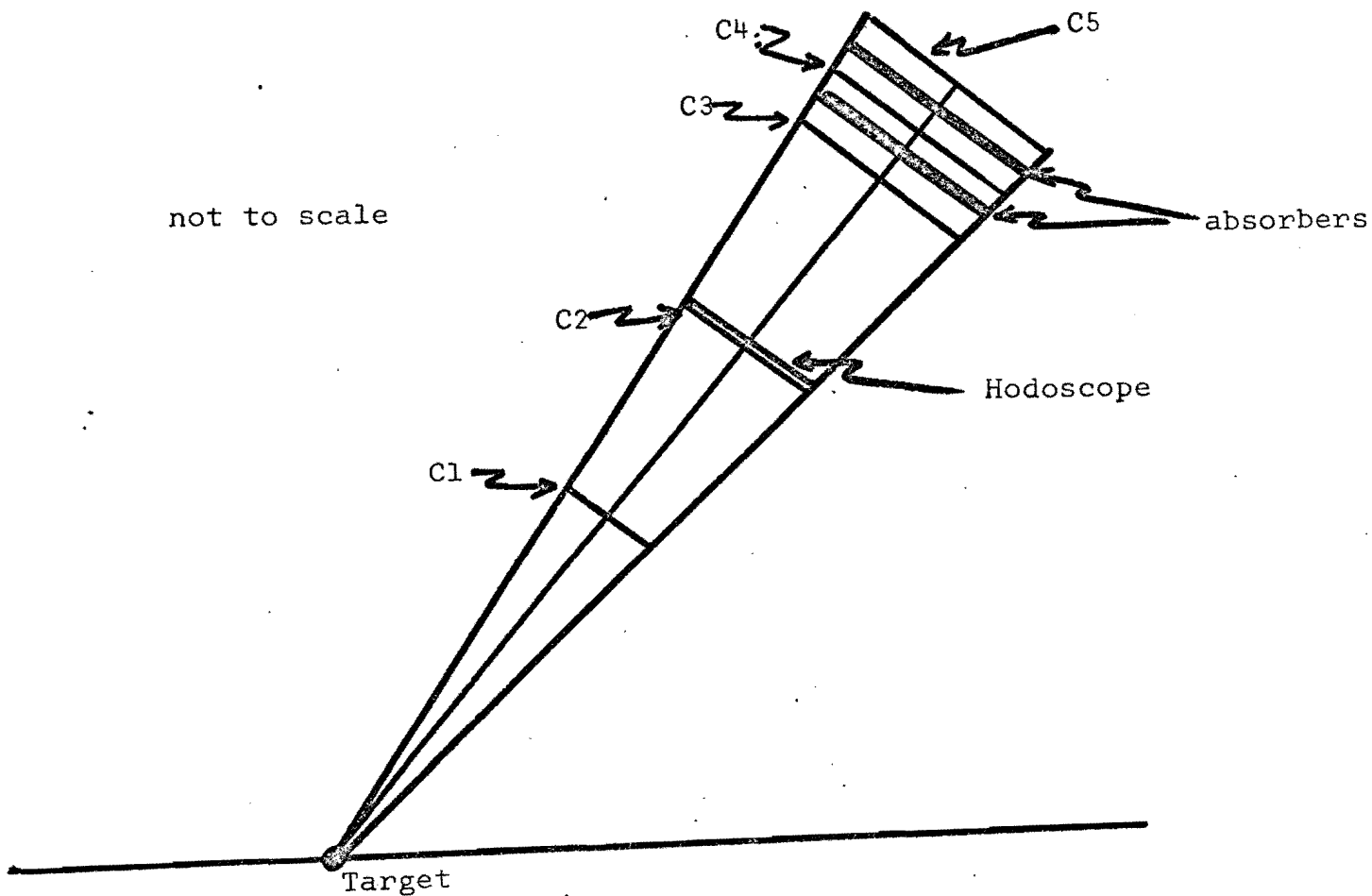

II. Resonance

Resonances were assumed to be spaced following the empirical interval rule $\Delta M^2 \approx 1 \text{ GeV}^2$. The physical widths were taken to be certain fractions of the spacing. Obviously the cleanest detections are for the narrowest widths and, as expected, the spectrometer was insensitive to resonances with widths \approx spacing between neighboring bumps. As the mass increases, there are reasons to expect resonances to become narrower more quickly than the spacing between resonances decreases.¹ The cross section for resonance production was taken to be of the form $\frac{d\sigma_{\text{Res}}}{dt} = A\lambda^{bt}$. The value of $b = 5 \text{ (GeV)}^{-2}$ was assumed² and, by fixing the value of $\sigma_{\text{Res}}^{\text{tot}}$, the constant A is determined by integration.

III. Background

The amount of nonresonant background relative to resonances was determined in the following way. First, a simple expression for the inelastic background was found which reproduced the data of Awschalom and White.³ The empirical form found was

$$\frac{d\sigma_{\text{inel.}}}{dP_{\perp} dP_{11}} = f(P_{\perp}) g(P_{11}) = [P_{\perp} e^{-4P_{\perp}^2}] \left[\frac{P_{11} - P_{\text{max}}}{0.6 P_{\text{max}}} \right]^2$$

where P_{\perp} , P_{11} are in c. of m. This result is similar to that of Trilling.⁴

The cross section for background accepted by our apparatus can then be determined by integration to be

$$\Delta\sigma_{Bg} = \frac{\int_{\text{acceptance}} f(P_{\perp}) g(P_{11}) dP_{\perp} dP_{11}}{\int_{\text{everywhere}} f(P_{\perp}) g(P_{11}) dP_{\perp} dP_{11}} \times \sigma_{inel.}$$

where σ_{inel} is taken to be 31.5 mb.

The cross section for a resonance to be accepted by our apparatus is

$$\Delta\sigma_{Res} = \int_{t \text{ min}}^{t \text{ max}} A e^{bt}$$

(where A and b are discussed in II).

Because we are looking in the region where, with A constant and b variable, the lines $\frac{d\sigma}{dt}$ vs t cross, the value of $\Delta\sigma_{Res}$ is insensitive to the exact value of b used (within the range $2 \leq b \leq 15$).

The number of background particles N_{Bg} is then related to the number of resonance particles N_{Res} by

$$\frac{N_{Bg}}{N_{Res}} = \frac{\Delta\sigma_{Bg}}{\Delta\sigma_{Res}}$$

Because the background function has no structure and varies slowly over the hodoscope, background particles were distributed randomly over the hodoscope counters according to the background distribution.

Since the total background is in correct proportion to the number of resonance particles the size of statistical fluctuations of background relative to resonance peaks is shown for an assumed σ_{Res}^{tot} and assumed total experimental counts.

1. H. Goldberg, Phys. Rev. Letters 21, 778 (1968).
2. H. Satz: "On the Mass Dependence of Momentum Transfer Distributions", Preprint TH.1175-CERN, 4 June 1970. This paper predicts an asymptotic value of b for two-body (resonant + non-resonant) production of: $b \rightarrow 5$ as $M \rightarrow \infty$.
3. M. Awschalom and T. White, "Secondary Particle Production at 200 GeV", NAL Preprint, FN-191, June 1969.
4. G. Trilling, "Pion and Proton Fluxes From High Energy Proton Collisions", UCID-10148, ~~as~~/Experimental, 2 May 1966.

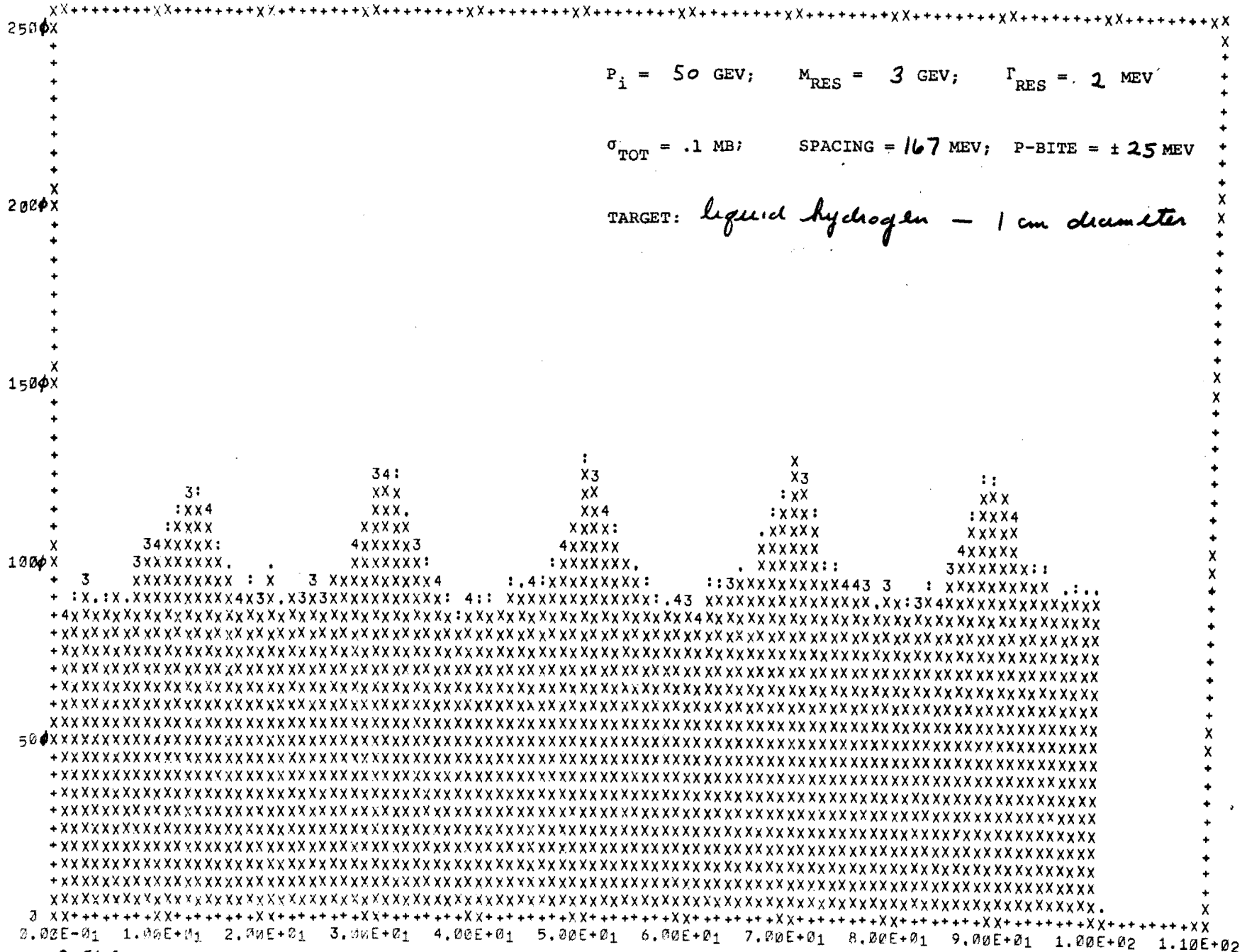

2.51 GEV

HODOSCOPE ELEMENT (MASS)

3.4 GEV

TOTAL WEIGHT OF EVENTS PLOTTED = 9867.0
DATE: 02/24/71 TIME: 03:37:34 RUNT:

= 49.7859 WIDTH= 28.7459
LAST CALL = 721.900 SEC.

TIME/EVENT = 0.36095

PLOT NUMBER 2

HODTH

NUMBER OF EVENTS

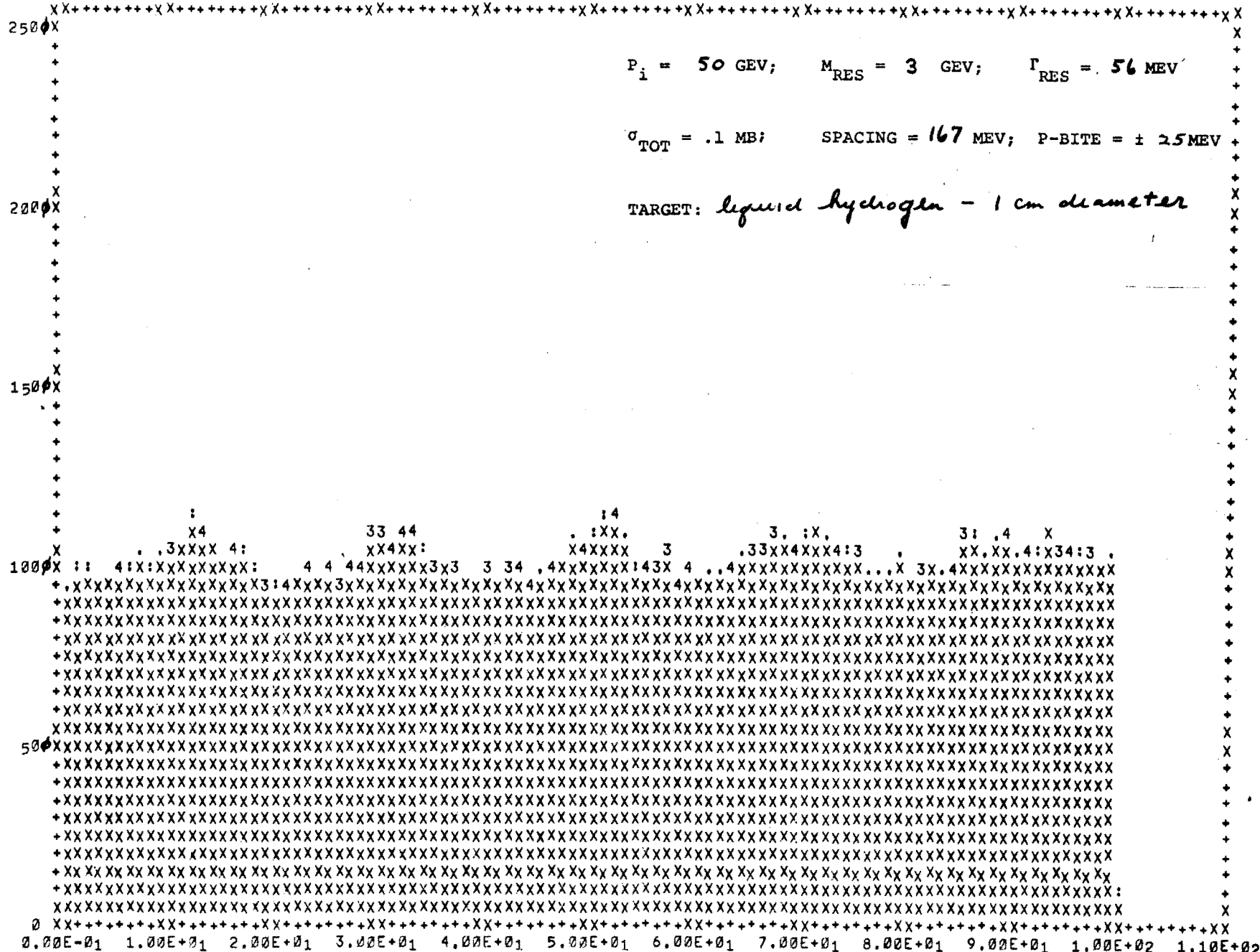

0.00E+01 1.00E+01 2.00E+01 3.00E+01 4.00E+01 5.00E+01 6.00E+01 7.00E+01 8.00E+01 9.00E+01 1.00E+02 1.10E+02

2.51 GeV

HODOSCOPE ELEMENT (MASS)

3.4 GeV

TOTAL WEIGHT OF EVENTS PLOTTED = 10492.3
 DATE: 02/24/71 TIME: 01:04:06 RUNT
 AVG. = 49.8828 WIDTH = 28.8711
 TIME SINCE LAST CALL = 717.850 SEC. TIME/EVENT = 0.35892

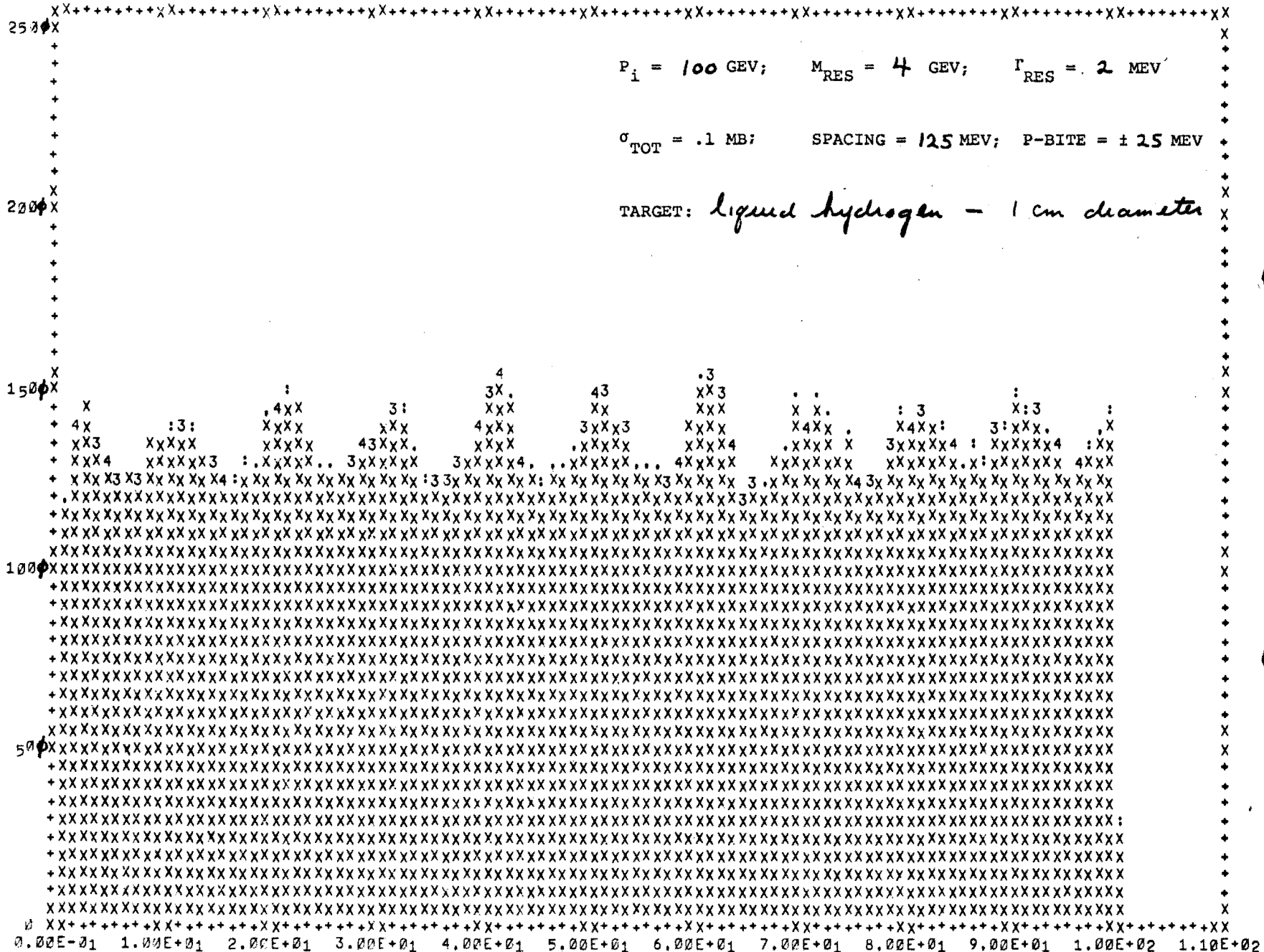

3.28 GEV

HODOSCOPE ELEMENT (MASS)

4.58 GEV

TOTAL WEIGHT OF EVENTS PLOTTED = 13404.0
DATE: 02/24/71 TIME: 01:34:17 RUNT:

= 49.874₂ WIDTH= 28.8870
LAST CALL = 1198.150 SEC. TIME/EVENT = 0.59907

PLOT NUMBER 2

HODTH

$P_i = 100$ GEV; $M_{RES} = 6$ GEV; $\Gamma_{RES} = 2$ MEV

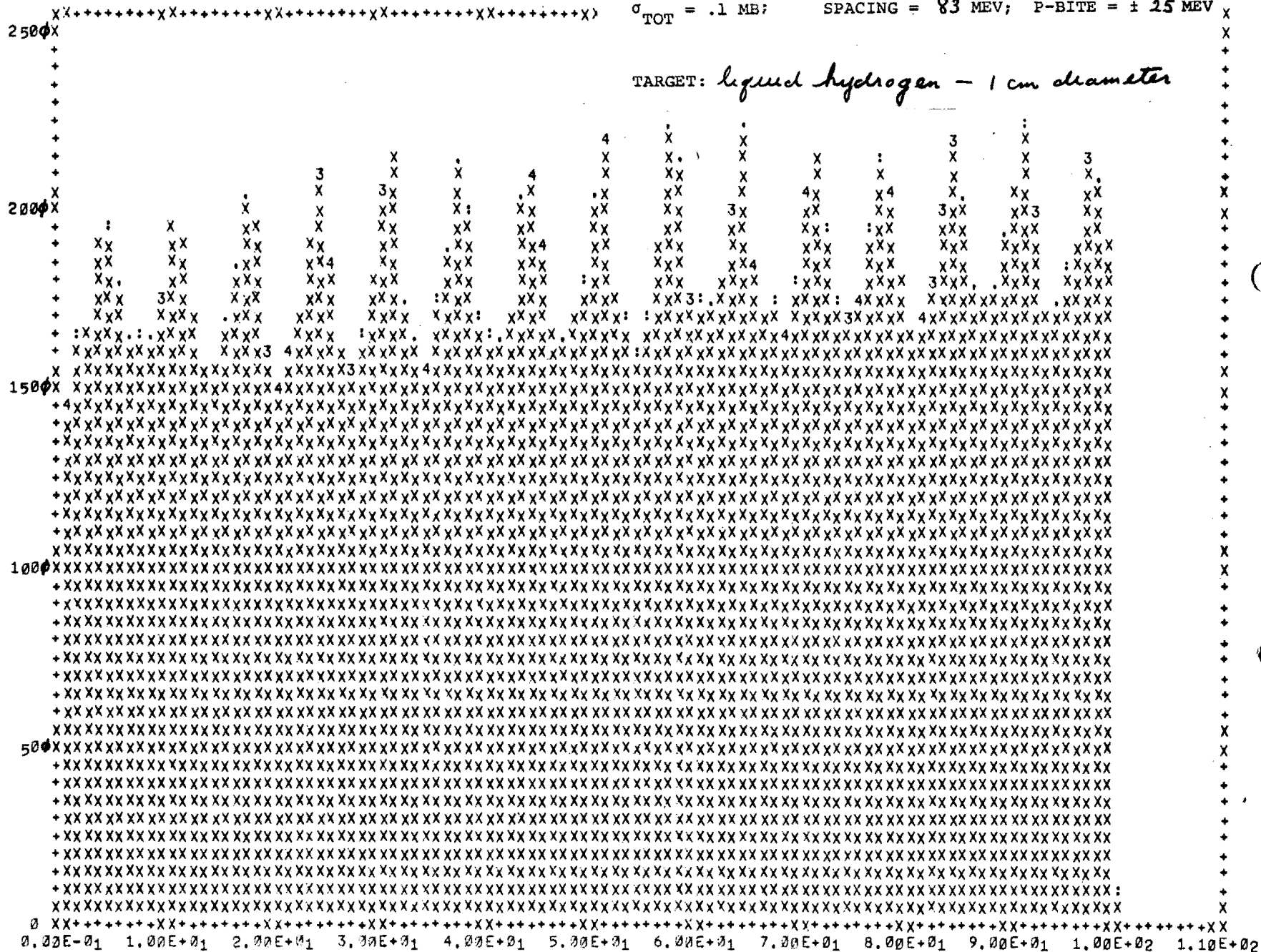

PLOT NUMBER 2

HODOTH

P_i = 100 GEV;

M_{RES} = 8 GEV;

Γ_{RES} = .2 MEV

XX++++++XX++++++XY++++++XX++++++XX++++++X

2500X

σ_{TOT} = .1 MB;

SPACING = 63 MEV;

P-BITE = ± 15 MEV

TARGET: liquid hydrogen - 1 cm. diameter

NUMBER OF EVENTS

2000X

1500X

1000X

500X

0.00E+01 1.00E+01 2.00E+01 3.00E+01 4.00E+01 5.00E+01 6.00E+01 7.00E+01 8.00E+01 9.00E+01 1.00E+02 1.10E+02

7.34 GeV

8.56 GeV

HODOSCOPE ELEMENT (MASS)

TOTAL WEIGHT OF EVENTS PLOTTED = 14618.0

DATE: 02/23/71 TIME: 22:11:28

RUNT: 00:11:00

VG. = 52.3159 WIDTH = 28.8035

TIME SINCE LAST CALL = 5688.017 SEC.

TIME/EVENT = 2.84401



$$P_1 = 200 \text{ GeV}/c$$

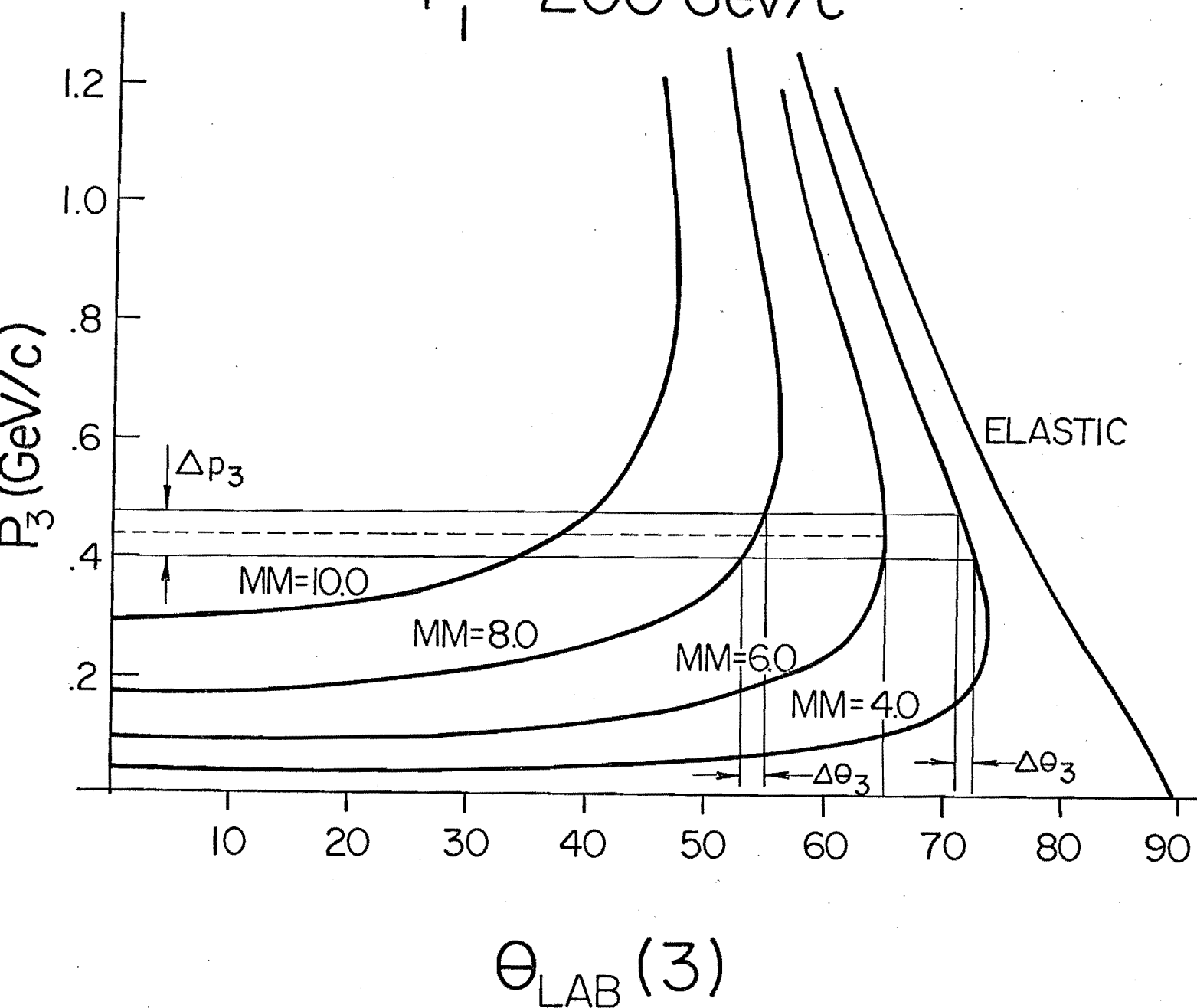

When the spectrometer is set at the Jacobian peak of a given missing mass (6.0 GeV in this example), a finite recoil momentum bite Δp_3 produces a small spread in the recoil angle θ_3 . However, the apparatus also accepts masses, which are not at their Jacobian peaks. These masses will have recoil angles with spreads $\Delta \theta_3$ and, therefore, reduced mass resolution. One solution to this problem is to reduce the size of Δp_3 . This effect is shown in the following two computer outputs which have identical input except for the size of Δp_3 .

PLOT NUMBER 2

WIDTH

$P_i = 200$ GEV; $M_{RES} = 5.5$ GEV; $\Gamma_{RES} = 2$ MEV

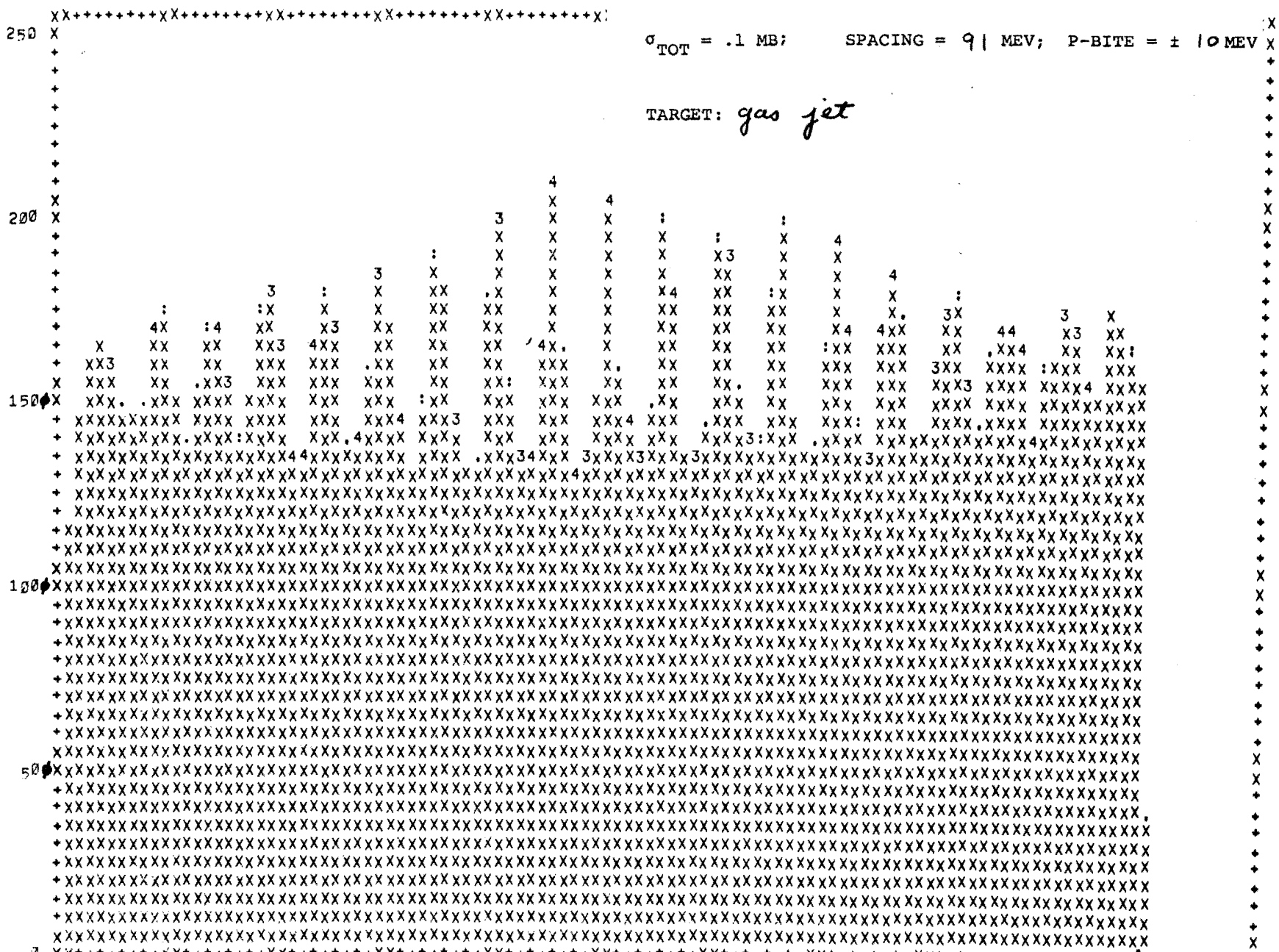

$\sigma_{TOT} = .1$ MB; SPACING = 91 MEV; P-BITE = ± 10 MEV

TARGET: *gas jet*

NUMBER OF EVENTS

0.00E+01 1.00E+01 2.00E+01 3.00E+01 4.00E+01 5.00E+01 6.00E+01 7.00E+01 8.00E+01 9.00E+01 1.00E+02 1.10E+02

4.46 GeV/c

6.94 GeV/c

HODOSCOPE ELEMENT (MASS)

PLOT NUMBER 2 HODTH

P_i = 200 GEV; M_{RES} = 5.5 GEV; Γ_{RES} = 2 MEV

250 φ X σ_{TOT} = .1 MB; SPACING = 91 MEV; P-BITE = ± 25 MEV X

TARGET: gas jet

NUMBER OF EVENTS

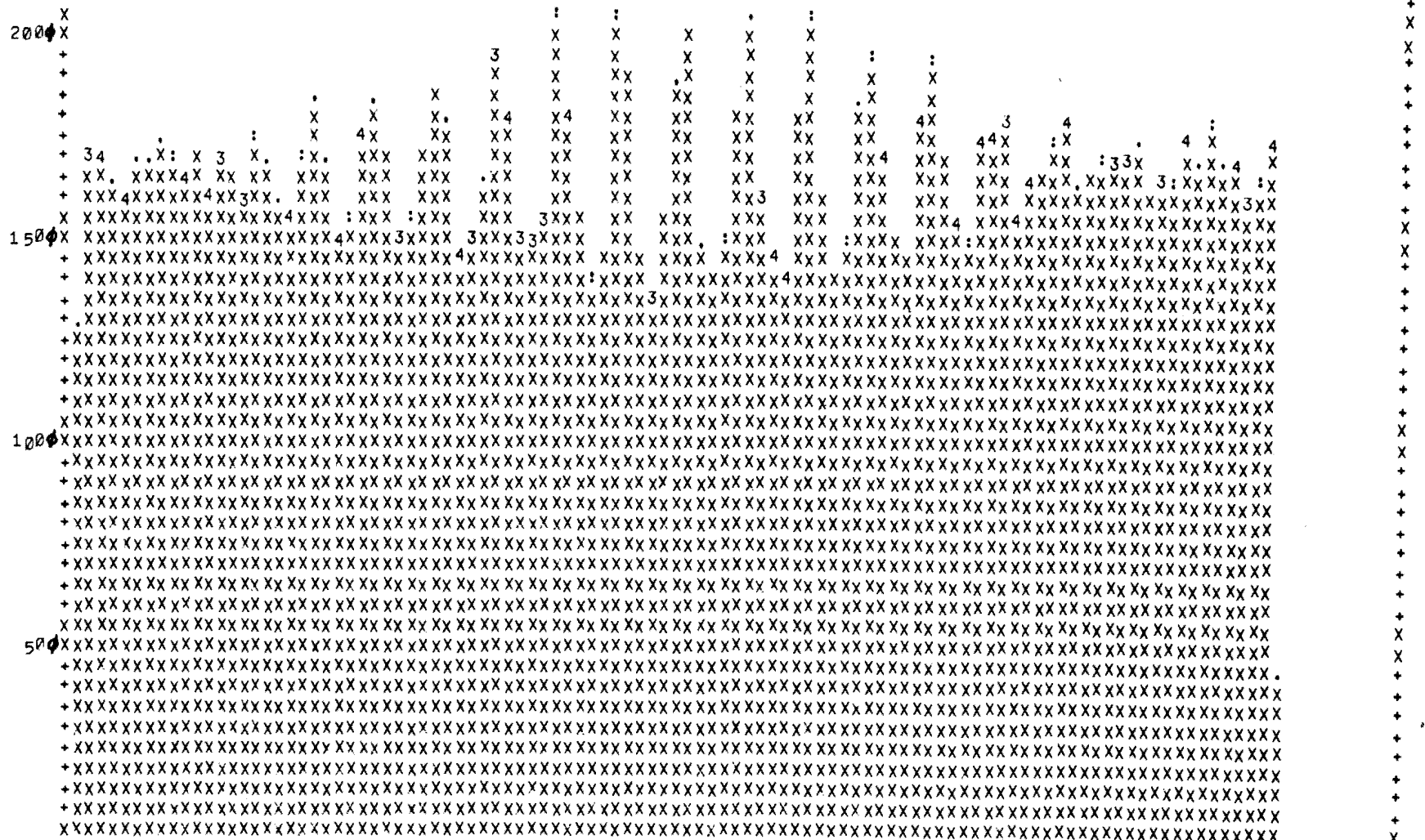

0 XX+++++XX+++++XX+++++XX+++++XX+++++XX+++++XX+++++XX+++++XX+++++XX+++++XX+++++XX+++++XX

4.46 GEV

HODOSCOPE ELEMENT (MASS)

6.34 GEV

TOTAL WEIGHT OF EVENTS PLOTTED = 16545.4 AVG. = 49.8854 WIDTH = 28.9100

DATE: 22/22/71 TIME: 23:27:05 RUN# REMAINING TIME SINCE LAST CALL = 2203.900 SEC. TIME/EVENT = 1.10195

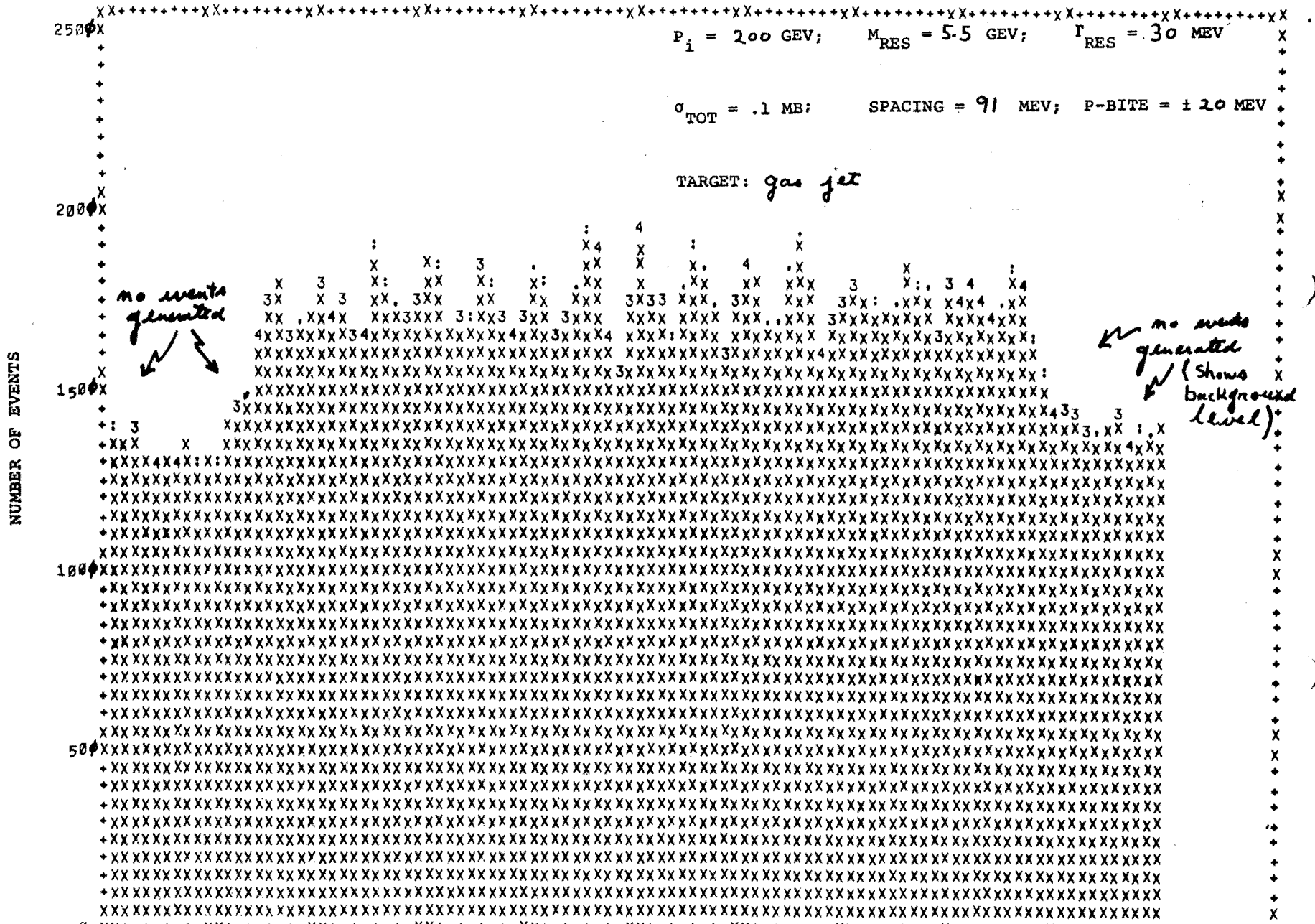

$P_i = 200 \text{ GEV}; M_{RES} = 5.5 \text{ GEV}; \Gamma_{RES} = .30 \text{ MEV}$

$\sigma_{TOT} = .1 \text{ MB}; \text{SPACING} = 91 \text{ MEV}; \text{P-BITE} = \pm 20 \text{ MEV}$

TARGET: gas jet

NUMBER OF EVENTS

0.00E+01 1.00E+01 2.00E+01 3.00E+01 4.00E+01 5.00E+01 6.00E+01 7.00E+01 8.00E+01 9.00E+01 1.00E+02 1.10E+02
 4.46 GEV 6.34 GEV

HODOSCOPE ELEMENT (MASS)

TOTAL WEIGHT OF EVENTS PLOTTED = 16388.0 AVG. = 49.9744 WIDTH = 27.7261
 DATE: 02/19/71 TIME: 22:57:30 RUNT DURATION SINCE LAST CALL = 1805.250 SEC. TIME/EVENT = 0.90263

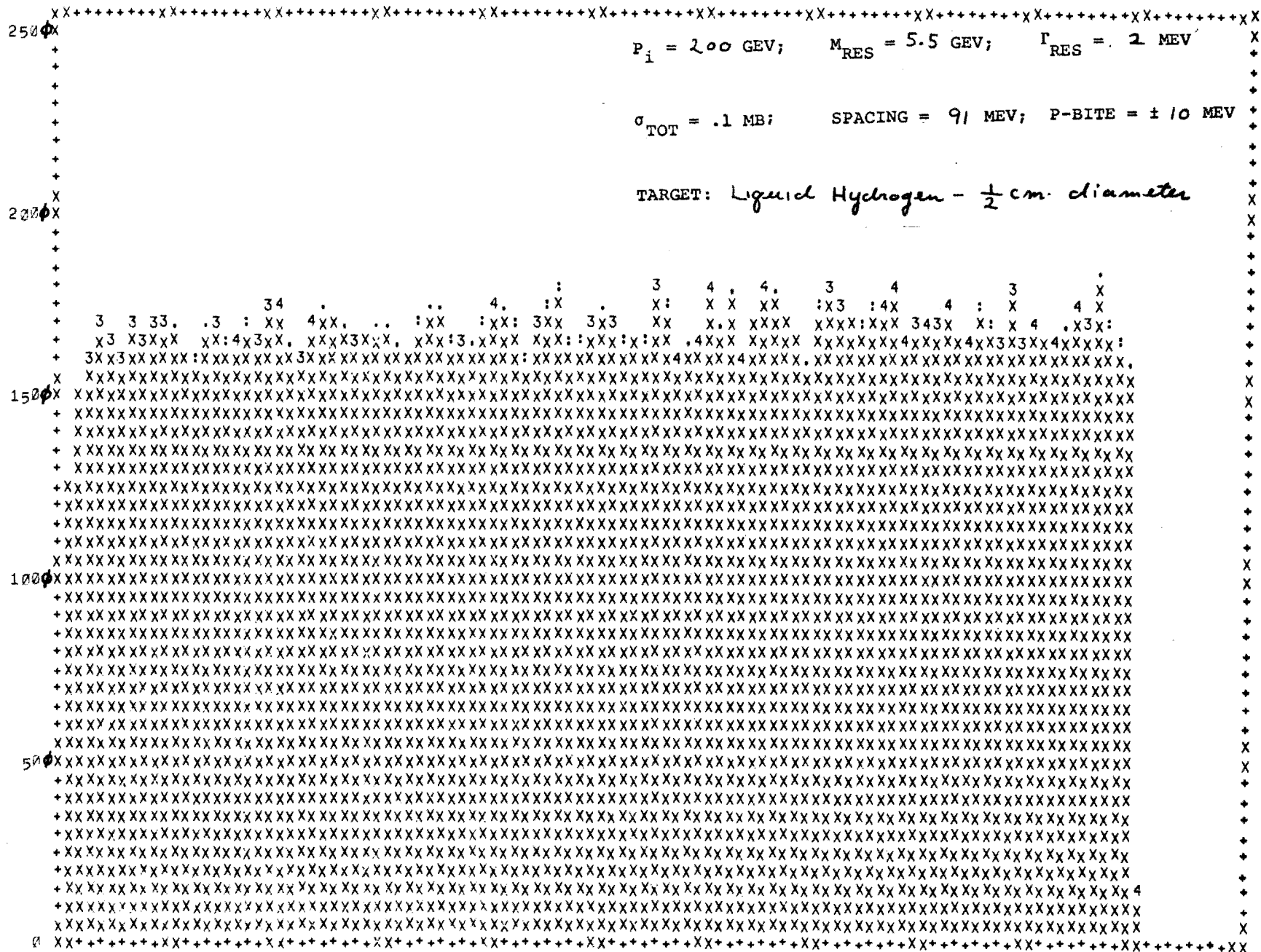

NUMBER OF EVENTS

$1.00E+01$ $1.00E+01$ $1.00E+01$ $1.00E+01$ $1.00E+01$ $1.00E+01$ $1.00E+01$ $1.00E+01$ $1.00E+01$ $1.00E+01$ $1.00E+02$ $1.10E+02$
4.46 GeV **6.34 GeV**

PLOT NUMBER 2

HODITH

3

P_i = 200 GEV; M_{RES} = 10 GEV; Γ_{RES} = 2 MEV

*X X + + + + X X + + + + *X X + + + + X X + + + + X X + + + + X X + + + + X X + + + + X X + + + + X X

σ_{TOT} = .1 MB; SPACING = 50 MEV; P-BITE = ± 15 MEV

TARGET: gas jet

1200 X

level
of
background
↓

NUMBER OF EVENTS

900 X

600 X

300 X

0.00E+01 1.00E+01 2.00E+01 3.00E+01 4.00E+01 5.00E+01 6.00E+01 7.00E+01 8.00E+01 9.00E+01 1.00E+02 1.10E+02
9.03 GeV HODOSCOPE ELEMENT (MASS) 10.81 GeV

TOTAL WEIGHT OF EVENTS PLOTTED = 10951 AVG. = 51.7159 WIDTH = 28.1862
DATE: 02/23/71 TIME: 03:40:00 RUN: 000000 RUNNING TIME SINCE LAST CALL = 4239.567 SEC. TIME/EVENT = 4.23957

PLOT NUMBER 2

DEPTH

P_i = 200 GEV; M_{RES} = 10 GEV; Γ_{RES} = 2 MEV

X X ++++++ X X ++++++ X X ++++++ X X ++++++ X X ++++++ X X

σ_{TOT} = .1 MB; SPACING = 50 MEV; P-BITE = ± 15 MEV

TARGET: liquid hydrogen - diameter = 1/2 cm.

NUMBER OF EVENTS

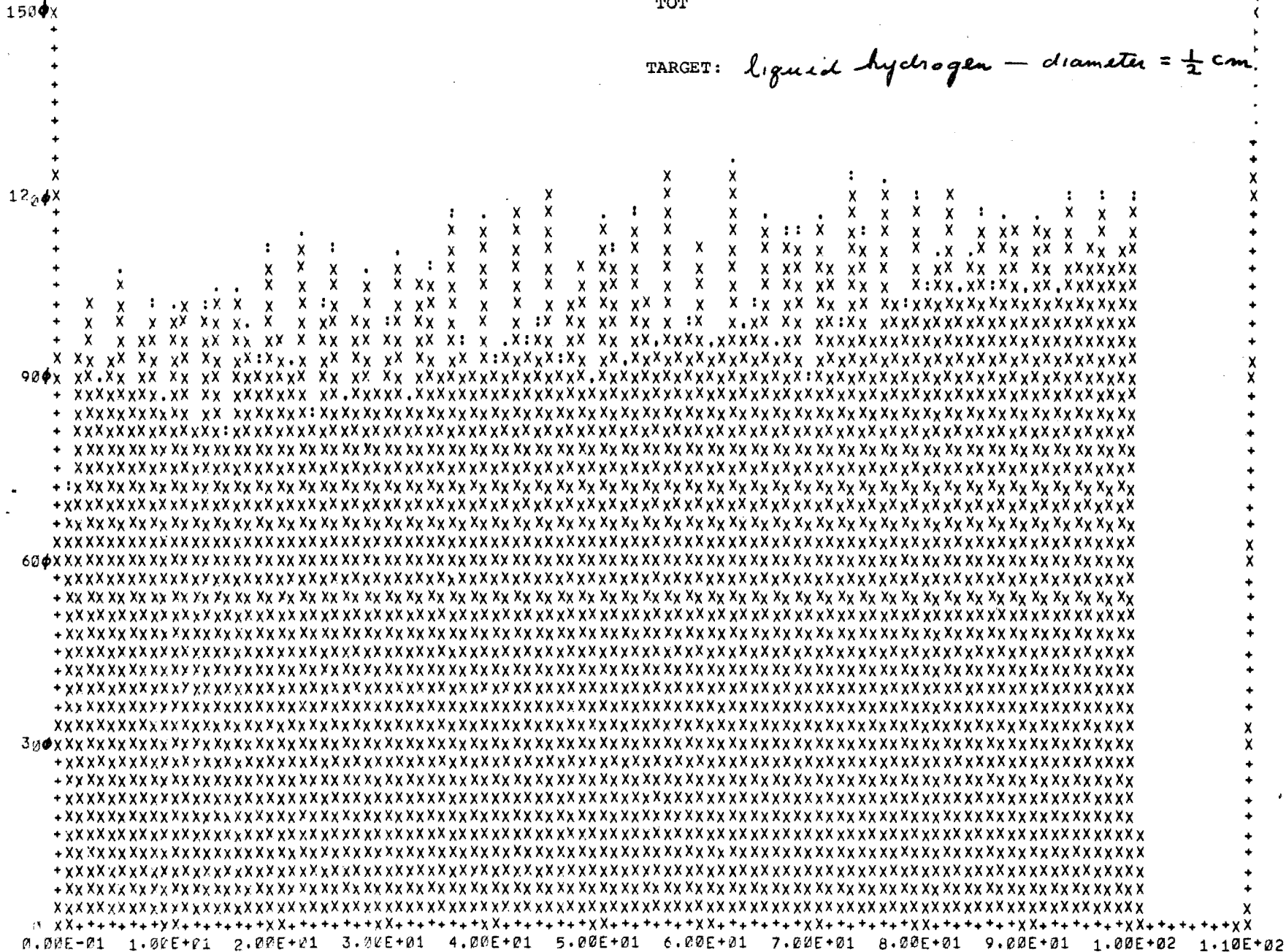

9.03 GeV HODOSCOPE ELEMENT (MASS) 10.81 GeV

TOTAL WEIGHT OF EVENTS PLOTTED = 10296.5 G. = 51.2814 WIDTH = 28.8276
DATE: 02/23/71 TIME: 03:10:01 RUNT: 5092.217 SEC. TIME/EVENT = 5.09222

Revised

TABLE 5

Comparison of Options

FEATURES:	Option 1A 10^{13} extracted p's	Option 1B 10^{13} extracted p's	Option 2 10^{10} extracted p's	Option 3 internal beam
1. Simplicity of setup	gas jet target, 100 el. hodo- scope, 5 trig- ger counters	Liq. Hyd. target, 100 el. hodo- scope, 5 trig- ger counters	Liquid H tar- gets, 100 el. hodoscope, 5 trigger count- ers	Gas jet target 5 counter telescope
2. Simplicity of opera- tion	change angle, timing and range between runs	change angle, timing and range between runs	change angle, timing and range between runs	No change (fixed para- meters for all masses)
3. Resolution (MeV)	± 12 to ± 24	± 14 to ± 33	± 14 to ± 23	± 13 to ± 26 .
4. Events per 1.8 GeV per day (res + nonres)	2×10^6	6×10^{10}	6×10^7	2×10^{10}
5. Peak signi- ficance \underline{s} per day (16)	.45%	.003%	0.1%	.005%
6. Sensitivity $\underline{S}=5s$ to see peak/day (17)	2.2%	.017%	0.5%	.022%
7a. Running time to scan mass band 4-10 GeV to get $\underline{S}=1\%$	15 days	1.5 minutes	1 day	1.2 minutes
7b. Running time to scan mass band 4-10 GeV to get $\underline{S}=0.1\%$	1.5×10^3 days	150 minutes	10^2 days	2.4 hours
8. Expansion of Exp. area needed	YES	YES	NO	NO
9. Can be done as soon as..	...beam is extracted	... beam is extracted	...Exp. area 2 is open	...Beam is accelerated