

KEK-PREPRINT-92-66



3

KEK Preprint 92-66  
July 1992  
A

# HOM-Free Linear Accelerator Structure using Choke Mode Cavity

Tsumoru, SHINTAKE

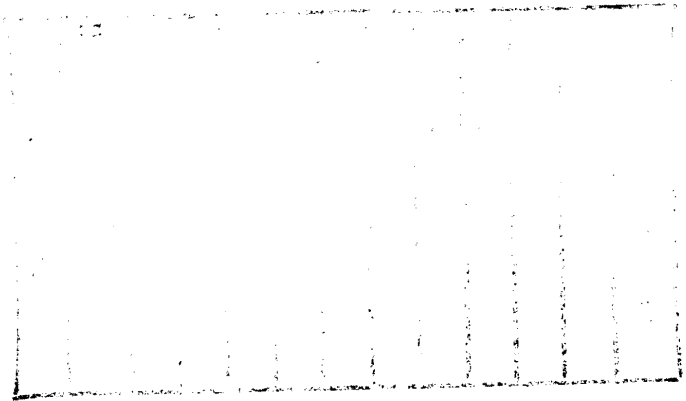

*Contributed to the 17th Linear Accelerator Meeting in Japan,  
Sendai, Japan, Sept. 1-3, 1992.*

SHINTAKE  
1992  
FERMILAB

**National Laboratory for High Energy Physics, 1992**

KEK Reports are available from:

Technical Information & Library  
National Laboratory for High Energy Physics  
1-1 Oho, Tsukuba-shi  
Ibaraki-ken, 305  
JAPAN

Phone: 0298-64-1171  
Telex: 3652-534 (Domestic)  
(0)3652-534 (International)  
Fax: 0298-64-4604  
Cable: KEKOH

# HOM-Free Linear Accelerating Structure using Choke Mode Cavity

Tsumoru SHINTAKE

*KEK: National Laboratory for High Energy Physics  
Oho 1-1, Tsukuba-shi, Ibaraki 305 JAPAN*

## ABSTRACT

A new concept of damped accelerating cavity, named "Choke Mode Cavity", was proposed by the author<sup>(1)</sup>. The boundary of this cavity is not closed, it is a kind of "Open Cavity", and all of the wake field power can easily run away through open slot into free space. Only the accelerating mode is trapped inside the resonator by imaginary short due to choke structure. In this paper, discussions are given on application for linear accelerating structures.

## 1. Introduction

In many particle accelerators, coupled bunch beam instability causes harmful damages on the beam, such as the emittance growth, energy distortion or beam losses. It is well known that this instability is mainly caused by the higher order mode impedances in the accelerating cavity. Therefore, several kind of cures to damp the higher order modes have been proposed<sup>(2,3,4)</sup>. These methods are based on selective coupling to the higher order modes, while keeping isolation from the accelerating mode, by utilizing the difference of wall current flow patterns between the accelerating mode and higher order modes, or utilizing cutoff effect in rectangular waveguide (high path filter).

The Choke Mode Cavity utilizes a different kind of phenomena for the mode selection, that is, frequency filtering by a choke ( notch filter).

## 2. Wake Field Damping and Accelerating Mode Trap

Figure 1 is a schematic illustration of a disk-loaded accelerating structure using Choke Mode Cavity. This structure is constructed by staking many number of disks. In principle, no electrical contact is necessary between disk to disk. Of course mechanical support and cooling system are necessary in a practical structure. When a bunched beam is passing in this structure, the beam radiates wake fields. Because, there is no closed metallic boundary around the beam, the wake fields propagate outward between disks and finally escape from the structure by radiating into free space. We may put a microwave absorbers between disks, or outside the structure.

On the other hand, for the accelerating mode, we need to trap the electromagnetic energy. For this purpose, a choke structure is implemented as shown in the figure. Because, the choke length is choose to  $\lambda/4$  at the accelerating frequency, the accelerating rf-power is reflected back to the cavity.

The distance from the choke to the cavity wall is chosen to also  $\lambda/4$ . Thus the choke establishes an imaginary short at the entrance of the slot. Therefore, the accelerating mode plays as if there is a perfect metallic boundary without slot.

Experimental measurements<sup>(1)</sup> on a model cavity of single cell S-band structure showed good damping for most of all modes, and Q-value of 6200 for accelerating mode, this is 85% of analytical value of a pill-box cavity.

### 3. Wake Field Calculation

Using the TBCI code, wake fields were calculated for the structures of Fig. 2. As shown in Fig. 3(a), the longitudinal wake potential shows small beating, this is due to overlapping of TM<sub>021</sub> oscillation at 9 GHz, which was not damped due to third choke resonance (see Fig. 4 in ref. 1). By modifying the choke shape as Fig. 2(b), TM<sub>021</sub> mode is eliminated and we have good sinusoidal accelerating mode oscillation as shown in Fig. 3(b). The transverse wake potential Fig. 3(c) shows exponential damping. The main oscillation component is TM<sub>110</sub> mode at 4.6 GHz, and whose Q-value is less than 10.

### 4. Linear Collider Application

Because the Choke Mode Cavity has cylindrical symmetry, it can be machined only on a turning lathe. Therefore it is quite suitable for mass production of many cells in disk-loaded linear accelerating structure. From analytical calculations, it is known that the mechanical tolerance of the choke is about  $\pm 1\%$  to keep the radiation loss lower than 10% of the wall loss. This is quite easy to realize.

However, for practical realization, R&D works are required for good material of microwave absorber for the matched load. Of course we can attach small pieces of absorber in each disk, but for the cost consideration it will be better to put a large absorber on the wall of the vacuum chamber.

This structure is believed to be one of the best candidates for the main linac in the  $e^+e^-$  linear collider projects.

### Acknowledgements

The author wishes to thank to Prof. Y. Kimura for his encouragements on this work. The author wishes to thank to Dr. K. Oide and Dr. H. Matsumoto for their useful discussions.

### References

1. Tsumoru SHINTAKE, "The Choke Mode Cavity", KEK Preprint 92-51, July 1992, A
2. R.B. Palmer, "Damped Acceleration Cavities", SLAC-PUB-4542, July 1988 (A).
3. T. Kageyama, "Grooved Beam Pipe for Damping Dipole Modes in RF Cavities", proceedings of the 8th symposium on accelerator science and technology, Saitama, Japan, Nov. 25-27, 1991.
4. G. Conciauro, P. Arcioni, "A New HOM-Free Accelerating Resonator", proceedings of 2nd European Particle Accelerator Conference Nice, June 1990

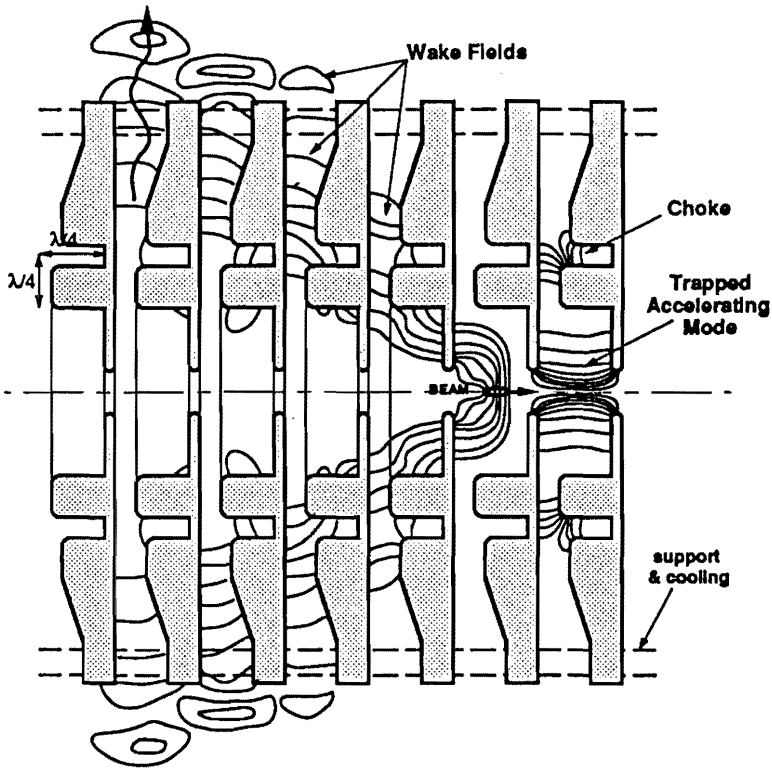
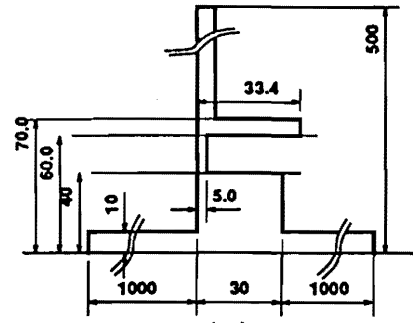
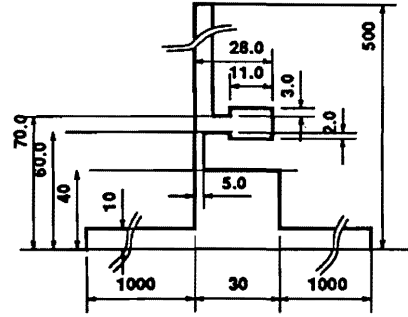

Fig. 1. Schematic illustration of HOM-free linear accelerating structure using choke mode cavity.



(a)



(b)

Fig. 2 Test cavity shape for wake field estimation.

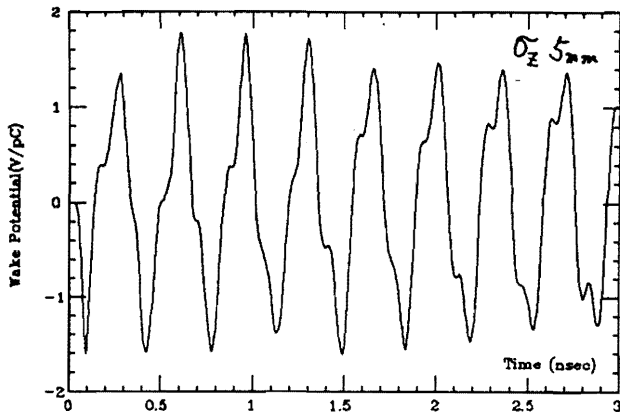

(a) Longitudinal wake potential of Fig. 2 (a).

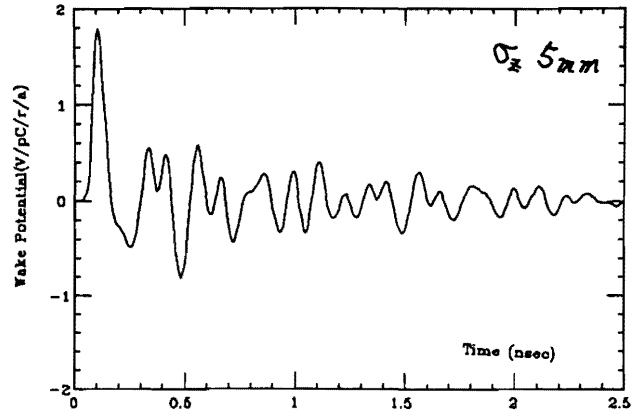

(c) Transverse wake potential of Fig. 2(a), integrated along trajectory at  $r = 10$  mm.

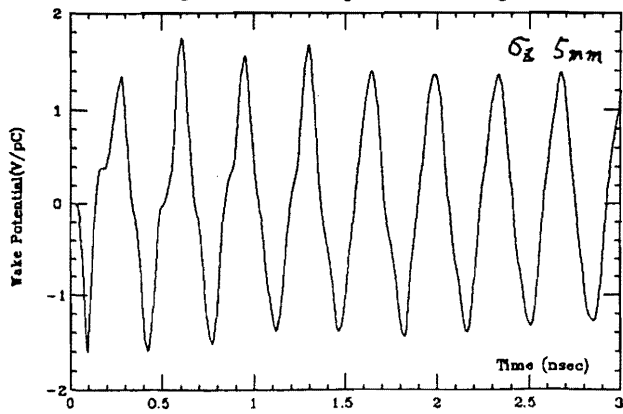

(b) Longitudinal wake potential of Fig. 2 (b).

Fig. 3 Wake potentials calculated by TBCI code. To simulate the wave absorption by microwave absorber, the radial line was extended to 0.5 m, whose end is closed. The reflection wave arrives after 3.3 nsec, i.e., before 3.3 nsec our simulations are not disturbed by the reflected wave. In order to avoid tube oscillation of TE<sub>11</sub> mode at 9 GHz, one meter long tubes were connected to the cavity.