

# HB650 CRYOMODULE DESIGN: FROM PROTOTYPE TO PRODUCTION\*

V. Roger<sup>†</sup>, S. Chandrasekaran, C. Grimm, J. Holzbauer, O. Napoly, J. Ozelis, D. Passarelli, Fermilab, Batavia, USA

## Abstract

In early 2023 the assembly of the prototype HB650 cryomodule (pHB650 CM) was completed and cold tests started to evaluate its performance. The lessons learned from the design, assembly and preliminary cold tests of this cryomodule, and from the design of the SSR2 pre-production cryomodule played a fundamental role during the design optimization process of the production HB650 cryomodule (HB650 CM). Several workshops have been organized to share experiences and solve problems. This paper presents the main design changes from pHB650 to the HB650 production cryomodules and their impact on the heat loads.

## INTRODUCTION

This pHB650 CM has been designed by an integrated design team, consisting of Fermilab (USA), CEA (France), STFC-UKRI (UK), and RRCAT (India) [1]. This cryomodule is the second PIP-II cryomodule which has been assembled at Fermilab using a strong-back supporting the entire coldmass [2]. This cryomodule is also the first one for which a standardization among all PIP-II cryomodules was applied [3]. Therefore, its completion and the on-going cryogenic tests have an important impact on all other PIP-II cryomodules especially for the production HB650 cryomodules which will be assembled by STFC-UKRI and for the pre-production and production LB650 cryomodules which are designed and assembled by CEA [4].

## LESSONS LEARNED

After the completion of the pHB650 CM assembly, the lessons learned from both cavity string assembly and cryomodule integration have been compiled and shared with Partners during workshops [3]. These lessons learned encompassed assembly process issues, design problems, component interferences, component QC, alignment issues, and opportunities for optimization.

### Assembly Process & Design Issues

While checking the alignment of the cavities with the HBCAMs before and after the coldmass insertion and while preparing the cryomodule for on-site transportation, additional lessons learned have been identified.

- One of the goals of the monitoring cameras (HBCAMs) were to check the alignment of the cavities after the coldmass insertion [5]. To do this, the HBCAMs locations with regards to the coldmass need

to be fixed. During the assembly process a support on wheels was used, which didn't provide enough precision. For next cryomodules, the HBCAM support will be part of the beam pipe end assembly tooling. Thus, the HBCAM support will remain attached to the coldmass during the insertion (see Fig. 1).

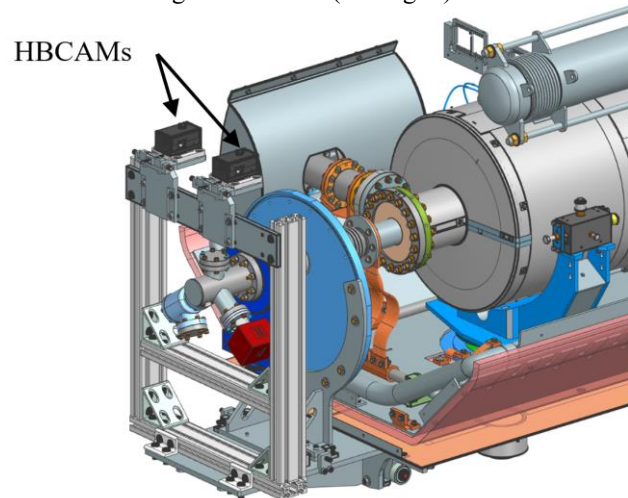

Figure 1: HBCAMs on the beam pipe end assembly tooling.

- The C-shape elements on each cavity lugs are used to keep the cavity aligned after cool-down [1] but also to constraint the cavity during transportation by using a cap. The plan was to use these caps only for transportation, but the latest calculations have shown that these caps can remain in place during the cold tests which will ease the assembly process. The Fig. 2 shows the design and location of these caps. Also, for production cryomodule the stiffness of the Belleville washers will be higher to make sure that the bearings are always in contact to the cavity.

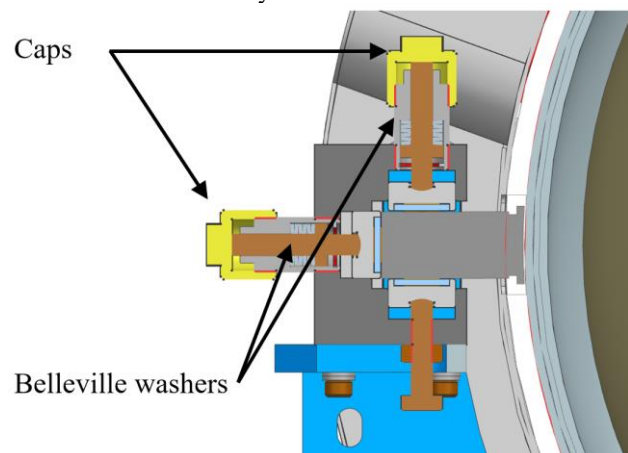

Figure 2: C-shape elements with caps.

\* Work supported by Fermi Research Alliance, LLC under Contract No. DE AC02 07 CH11359 with the United States Department of Energy

<sup>†</sup> vroger@fnal.gov

## Component Interferences

There were a few instances where interferences between components during assembly were encountered, potentially due to out-of-specification components or 3-D modeling not taking into account “real-world” tolerance adherence of components comprised of e.g., sheet metal, with attendant fabrication inaccuracies experienced, even though comprehensive 3-D modeling of the assembly did not uncover them. Some of this was later rectified for production by introducing adjustability in the assembly process, e.g., slotted holes to allow for small misalignment of magnetic shield sections, or changes to dimensions to provide more clearance between components.

## Component QC

Due to COVID-related supply chain issues, a number of components arrived late, reducing or in some cases, eliminating, the opportunity for comprehensive QC inspections as originally planned. Dealing with components that arrived in a “just-in-time” basis required that QC was basically performed during the assembly process. This resulted in assembly delays when components had to be re-worked in-house in order to meet specifications. This experience with unprecedented supply chain related delays prompted a much earlier start to the procurement cycle for components for the next FNAL-built PIP-II CM, the pre-production SSR2, in the hopes of avoiding the downstream impacts on performing incoming QC.

## TEST RESULTS AND HEAT LOADS ANALYSIS OF THE 1<sup>ST</sup> COOL-DOWN

No issue appeared during the cool-down of the cryomodule. Contrary to the prototype SSR1 cryomodule the strongback remained at room temperature. However, the static heat loads measurements were clearly out of tolerance especially the 2K heat loads including a 20 W difference by running the cavities at 4K or 2K.

Table 1: Static heat loads.

	Estimated heat loads	Measured heat loads
High Temperature Thermal Shield (HTTS)	150 W	250 W
Low Temperature Thermal Source (LTTS)	26 W	30 W
2K (with cavity at 4K)	11.2 W	33 W
2K (with cavity at 2K)	11.2 W	52 W

## 2K Heat Loads

From all the temperature sensors inside the coldmass, only two sensors on the middle G10 support read unexpected values (See Fig. 3), with values even higher than the temperature of the thermal shield. However, these high temperatures were not enough to explain high heat loads at 2K.

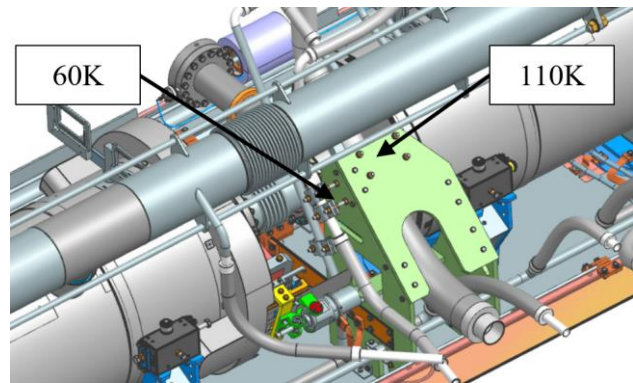

Figure 3: High temperature measured on the middle G10 support.

2K heat loads measurements have been done by running the HTTS temperature at 110K instead of 50K and also by removing the helium flow in the LTTS. For both cases the heat loads increased as expected. Thus, the radiation from room temperature to 2K became the main point of interest. Investigations have shown that the heat loads by radiation from the room temperature coupler parts which are inside the coldmass were not accounted for and MLI on the thermal shield was not close enough to the coupler.

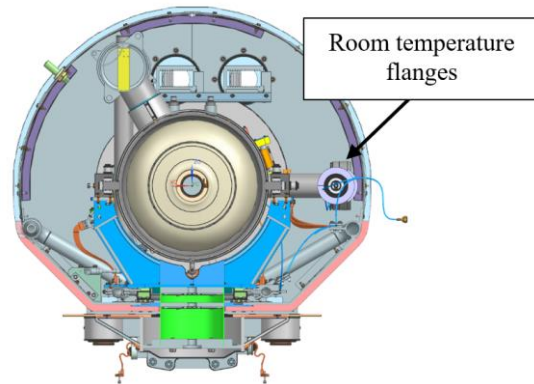

Figure 4: Coldmass cross section.

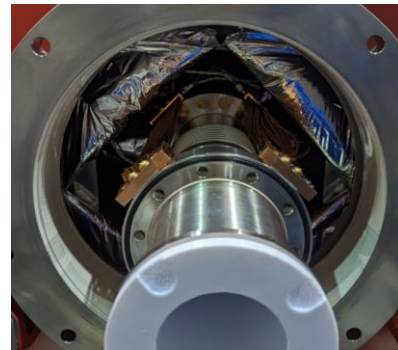

Figure 5: Warm part of the coupler going through the thermal shield.

Calculations showed that it was contributing to around 15 W to the 2K heat loads. The G10 emissivity being close to 1 and located right in front of one coupler, this radiation seems to be also responsible of the high temperatures measured on the middle G10 support. In addition, it was estimated that microphonics in the cool-down valve were contributing to around 5 W to the 2K heat loads. Therefore,

it seems that all the 2K heat loads discrepancies have been identified.

Concerning the heat loads difference with cavities at 2K and 4K, it is likely due to the “Rollin films” going up against the walls of the three flexible tubes inside the pressure transducer lines and making shorts with the thermal shield (See Fig. 6). 20 W due to “Rollin film” seems important but this phenomenon could be facilitated by more than 50 wires present inside each of these tubes. (See Fig. 7).

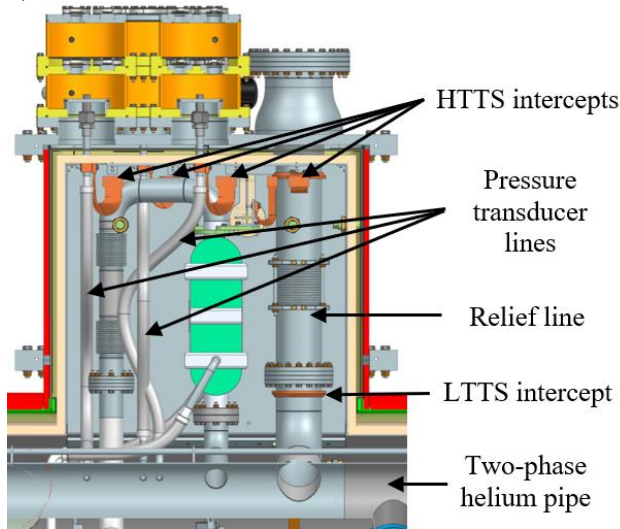

Figure 6: Pressure transducer lines and relief line interfaces.



Figure 7: Wires through the pressure transducer lines.

Temperature sensors located on the top part of the HTTS shows a temperature drop switching cavities from 4K to 2K which tends to validate this analysis (See Fig. 8 and Fig. 9)

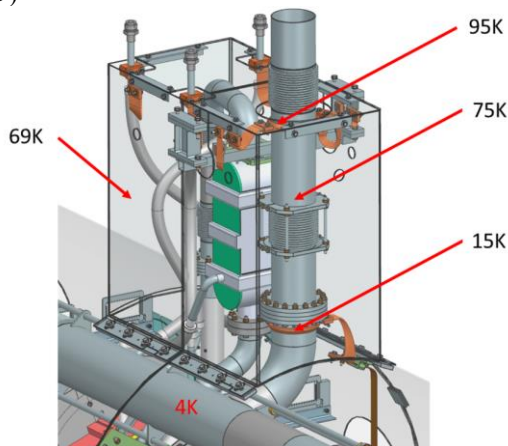

Figure 8: Temperature values with cavities at 4K.

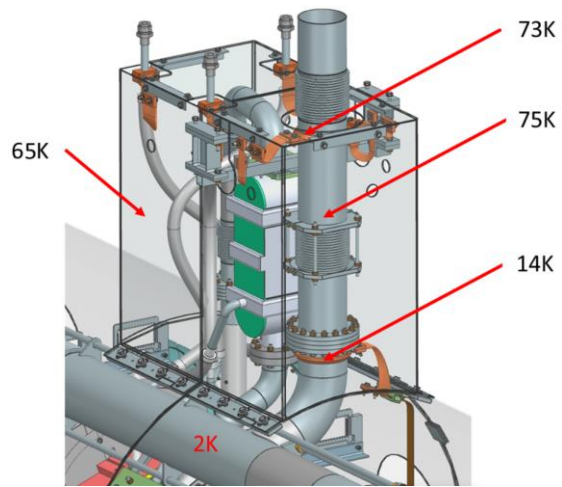

Figure 9: Temperature values with cavities at 2K.

### LTTS Heat Loads

Six temperature sensors are located along this line that shows a temperature increase of 2K in between couplers 4 and 3. This is likely due to the fact that the LTTS line is connected to the G10 middle support (See Fig. 10). Thus, part of the heat loads by radiation ends up on the LTTS.

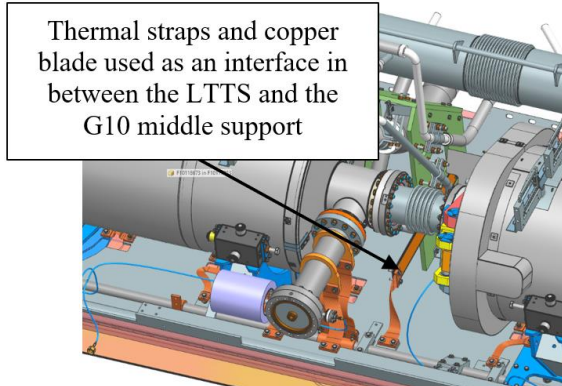

Figure 10: LTTS / G10 middle support interface.

### HTTS Heat Loads

On the HTTS heat loads, there is a discrepancy of 100 W in between the estimation and the measurements. Up to 60 W may be explained by radiation because there is no MLI on the inside of the thermal shield.

## IMPROVEMENTS PLANNED AFTER THE 1<sup>ST</sup> WARM-UP AND PATH FORWARD

To reduce the heat loads a plan has been set up to make design improvements after the 1<sup>st</sup> warm-up of the cryomodule. Each coupler port will be open, and the warm parts of the coupler will be removed. Then an aluminum plate will be connected to thermal shield (See Fig. 11 and Fig. 12) and MLI and tape will be set up to shield the radiation. Temperature sensor on the G10 support will be checked and MLI will be put on the G10 middle support. These improvements won't be good enough to fix completely the heat loads issue, but we expect to reduce them by 5 to 10 W. In addition, the temperature of the G10 middle support should drop significantly.

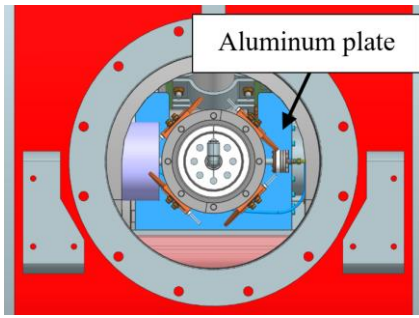

Figure 11: Additional aluminum plate - View from the coupler port.

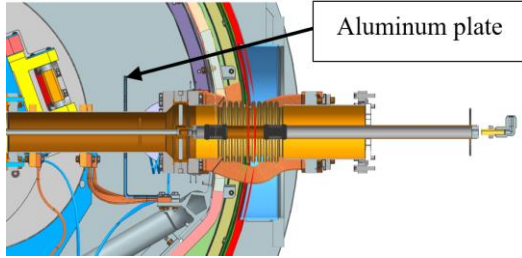

Figure 12: Additional aluminum plate - Cross section.

The microphonics in the cool-down valve should disappear by changing the material of the stem from stainless steel to G10. This material issue was noticed during the assembly of the cryomodule, but the manufacturer could not provide the appropriate stem on time for the 1<sup>st</sup> cool-down.

To validate that heat loads difference with cavities at 2K and 4K is due to the “Rollin films”, heaters will be installed at the bottom of each pressure transducer lines. If that is the case the heat loads should drop when the heaters are on. To save time during the warm-up, the top part of the cryomodule won't be removed, all the work will be done through an access port [1]. Thus, it won't be possible to add temperature sensors on the pressure transducer lines.

## DESCRIPTION OF THE PRODUCTION CRYOMODULE

The design optimization of the HB650 cryomodule (see Fig. 13) has been based on all the lessons learned from the design, assembly and preliminary cold tests.

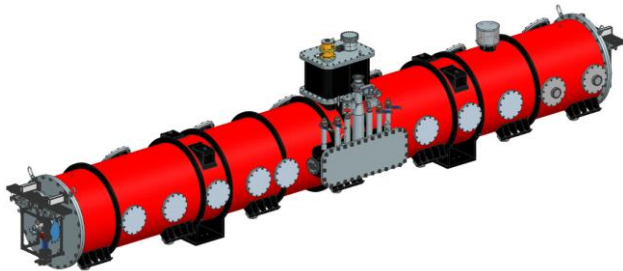

Figure 13: HB650 production cryomodule.

### Beam line

Contrary to the pHB650 CM, the beam line is composed exclusively of  $\beta = 0.92$  cavities. To be compatible with the STFC-UKRI cavity test facility, the cavity tee on the helium vessel has been removed.



Figure 14: HB650 production cavity.

Coupler design (See Fig. 15) has been also optimized changing interface with the cryogenic lines and with the vacuum vessel to ease the assembly process.

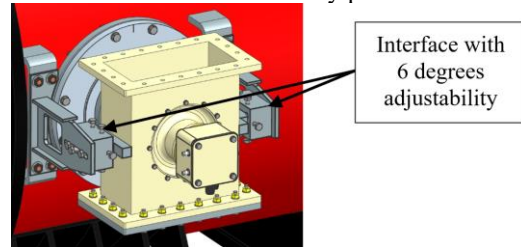

Figure 15: Production coupler / vacuum vessel interface.

### Vacuum Vessel & Global Magnetic Shield

As described in [3], the design of the vacuum vessel has been changed to match the manufacturing process, but the overall design didn't change. Only, the inner frame design welded on the inside of the vacuum vessel evolved by using exclusively flat plates assure a better fit with the global magnetic shield (see Fig. 16).

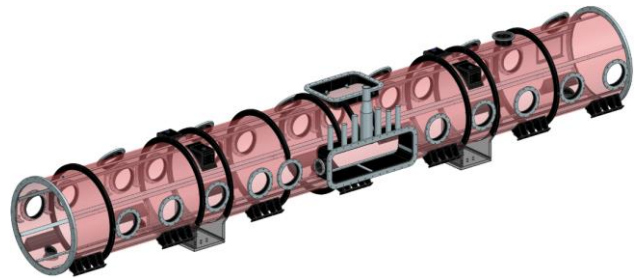

Figure 16: Skeleton on the inside of the vacuum vessel.

### HTTS

The coupler parts at room temperature are now outside the coldmass to reduce the heat loads by radiation (see Fig. 14). In addition, pre-cut MLI will be used to keep an appropriate gap in between the MLI and couplers.

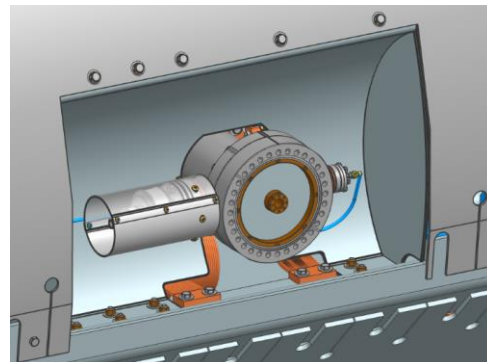

Figure 17: Production thermal shield design

## Pressure Transducer Line

On production cryomodule, there is no instrumentation inside the helium vessel of the cavities which means that no instrumentation other than the liquid level sensor is going through the pressure transducer line. Nevertheless, to make sure to break the “Rollin film” this line includes an intercept with the LTTS.

## Expected Heat Loads

The heat loads by conduction and radiation have been estimated analytically and listed in **Error! Reference source not found.2**.

Table 2: HB560 production cryomodule heat loads.

	HTTS	LTTS	2K
Static	148 W	26 W	10 W
Static and dynamic	160 W	27 W	130 W

## ACKNOWLEDGMENT

The authors would like to thank the cryogenic team in charge of cooling down the cryomodule, the cryomodule assembly team and the drafters for their contributions during all the phases of this project.

## CONCLUSION

After extensive cryogenic tests performed during the 1<sup>st</sup> cool-down of this prototype cryomodule, an heat loads analysis have been performed identifying the potential sources of the heat loads discrepancies in between the calculations and measurements. A path forward has been defined to improve the cryomodule during the 1<sup>st</sup> warm-up and then to validate this heat loads analysis during the 2<sup>nd</sup> cool-down by adding heaters and temperature sensors.

Based on this analysis and the lessons learned, the design of the production HB650 cryomodule has been optimized with all the room temperature parts outside the coldmass. If successful, the second cool-down will trigger the final design review of this cryomodule.

## REFERENCES

- [1] V. Roger, et al., “Design of the 650 MHz high beta prototype cryomodule for PIP-II at Fermilab”, In *Proc SRF’21*, Michigan state university, USA, Jun.-Jul. 2021, pp. 671-675 doi:10.18429/JACoW-SRF2021-WEPTEV015
- [2] V. Roger, et al., “Design strategy of the PIP-II cryomodules”, In *Proc SRF’19*, Dresden, Germany, Jun. 2019, pp. 307-310. doi:10.18429/JACoW-SRF2019-MOP094
- [3] V. Roger et al. ; Standardization and first lessons learned of the prototype HB650 cryomodule for PIP-II at Fermilab”, In *Proc LINAC’22*, Liverpool, UK, Aug. 2022, pp. 526-528. doi:10.18429/JACoW-LINAC2022-TUPOGE16
- [4] N. Bazin et al. ; “Design of the PIP-II 650 MHz low beta cryomodule”, In *Proc SRF’21*, Michigan state university, USA, Jun.-Jul. 2021, pp.841-844. doi:10.18429/JACoW-SRF2021-THPTEV006
- [5] C. Cheban et al ; “Alignment monitor system for the PIP-II cryomodules”, In *Proc SRF’19*, Dresden, Germany, Jun. 2019, pp. 332-334. doi:10.18429/JACoW-SRF2019-MOP102