

CERN/LHCC 2007-014

LHCC-G-131

15 March 2007

# CMS

## Expression of Interest in the

# SLHC

---

### CMS Upgrade Project

CMS Spokesperson	Tejinder Virdee, Imperial College London and CERN
CMS Technical Coordinator	Austin Ball, CERN
CMS Collaboration Board Chair	Lorenzo Foa, Pisa
Upgrade Steering Group Coordinator	Jordan Nash, CERN

---

## **Editor**

J. Nash

## **Chapter Editors**

D. Acosta, W. Smith, G. Hall, D. Baden, M. Dallavalle

## **Acknowledgments**

For their patience in meeting sometimes impossible demands, we wish to thank the CMS Secretariat: K. Aspola, M. Azeglio, N. Bogolioubova, D. Denise, D. Hudson, G. Martin, and M.C. Pelloux.

We also would like to thank G. Alverson and L. Taylor for their invaluable technical assistance in the preparation of this manuscript.

Finally, we wish to thank the CMS management for their strong support and encouragement.

**ISBN 978-92-9083-290-4**

**Trademark notice:** all trademarks appearing in this report are acknowledged as such.

Also available at: <http://cms.cern.ch/Documents/TDRs.html>

# CMS Collaboration

## **Yerevan Physics Institute, Yerevan, ARMENIA**

S. Chatrchyan, G. Hmayakyan, V. Khachatryan, A.M. Sirunyan

## **Institut für Hochenergiephysik der OeAW, Wien, AUSTRIA**

W. Adam, T. Bergauer, M. Dragicevic, J. Erö, M. Friedl, R. Fruehwirth, V. Ghete, P. Glaser, J. Hrubec, M. Jeitler, M. Krammer, I. Magrans, I. Mikulec, T. Noebauer, M. Pernicka, H. Rohringer, J. Strauss, A. Taurok, W. Waltenberger, G. Walzel, E. Widl, A.J. Winkler, C.-E. Wulz

## **National Centre for Particle and High Energy Physics, Minsk, BELARUS**

V. Chekhovsky, O. Dvornikov, I. Emeliantchik, A. Litomin, V. Makarenko, I. Marfin, V. Mossolov, N. Shumeiko, A. Solin, R. Stefanovitch, J. Suarez Gonzalez, A. Tikhonov

## **Research Institute for Nuclear Problems, Minsk, BELARUS**

A. Fedorov, M. Korzhik, O. Missevitch, R. Zuyeuski

## **Vrije Universiteit Brussel, Brussel, BELGIUM**

J. D'Hondt, S. De Weirdt, R. Goorens, J. Heyninck, S. Lowette, J. Maes, V.M. Petra Karel Ann, S. Tavernier, W. Van Doninck<sup>\*\*1</sup>, L. Van Lancker, P. Van Mulders, I. Villella

## **Université Libre de Bruxelles, Bruxelles, BELGIUM**

O. Bouhali, O. Charaf, B. Clerbaux, G. De Lentdecker, J.P. Dewulf, S. Elgammal, G.H. Hammad, T. Mahmoud, P.E. Marage, S. Rugovac, V. Sundararajan, C. Vander Velde, P. Vanlaer, J. Wickens

## **Université Catholique de Louvain, Louvain-la-Neuve, BELGIUM**

S. Assouak, J.L. Bonnet, G. Bruno, J. Caudron, F. Charlier, B. De Callatay, J. De Favereau De Jeneret, S. De Visscher, P. Demin, D. Favart, E. Feltrin, B. Florins, E. Forton, A. Giammanco, G. Grégoire, S. Kalinin, D. Kcira, T. Keutgen, V. Lemaître, Y. Liu, F. Maltoni, D. Michotte, O. Militaru, A. Ninane, S. Oryn, T. Pierzchala, K. Piotrkowski, V. Roberfroid, P. Rodeghiero, X. Rouby, N. Schul, O. Van der Aa

## **Université de Mons-Hainaut, Mons, BELGIUM**

N. Belyi, E. Daubie, P. Herquet

## **Universiteit Antwerpen, Wilrijk, BELGIUM**

W. Beaumont, M. Cardaci, E. De Langhe, E.A. De Wolf, S. Ochesanu, L. Rurua, P. Van Mechelen

## **Centro Brasileiro de Pesquisas Físicas, Rio de Janeiro, RJ, BRAZIL**

G. Alves, M.H.G. Souza, M.E. Pol

## **Instituto de Física - Universidade Federal do Rio de Janeiro, Rio de Janeiro, RJ, BRAZIL**

M. Vaz

## **Universidade do Estado do Rio de Janeiro, Rio de Janeiro, RJ, BRAZIL**

D. Buarque Franzosi, J.W. Costa, D.R. Da Silva Di Calafiori, D. De Jesus Damiao, L. Haas Pecanha Lessa, J.A. Lajas Sanches, D. Meirelles Martinho, V. Oguri, A. Santoro, S.M. Silava Do Amaral, A. Sznajder, A. Vilela Pereira

## **Instituto de Física Teórica-Universidade Estadual Paulista, Sao Paulo, SP, BRAZIL**

E.M. Gregores, R.L. Iope, S.F. Novaes, T. Tomei

## **Institute for Nuclear Research and Nuclear Energy, Sofia, BULGARIA**

T. Anguelov, G. Antchev, I. Atanasov, J. Damgov, N. Darmanov<sup>\*\*1</sup>, L. Dimitrov, V. Genchev<sup>\*\*1</sup>, G. Georgiev, A. Hristov, P. Iaydjiev, B. Panev, M. Peynekov, S. Piperov, G. Rashevski, S. Stoykova, G. Sultanov, I. Vankov

**University of Sofia, Sofia, BULGARIA**

A. Dimitrov, M. Dyulendarova, V. Kozhuharov, L. Litov, M. Makariev, A. Marinov, E. Marinova, S. Markov, M. Mateev, B. Pavlov, P. Petkov, C. Sabev, Z. Toteva<sup>\*\*1</sup>, V. Verguilov

**Institute of High Energy Physics, Beijing, CHINA**

J. Bai, G.M. Chen, H.S. Chen, P. Chen, W. Guan, Y.N. Guo, K.L. He, C.H. Jiang, Z.J. Ke, B. Li, J. Li, W.G. Li, B. Liu, H.M. Liu, G. Qin, J.F. Qiu, X.Y. Shen, G. Sun, H.S. Sun, C. Teng, Y.Y. Wang, Z. Xue, X. Yue, S.Q. Zhang, Y. Zhang, W.R. Zhao, G.Y. Zhu, H.L. Zhuang

**Peking University, Beijing, CHINA**

Y. Ban, J. Cai, L. Liu, S. Liu, S.J. Qian, Z.C. Yang, Y.L. Ye, J. Ying

**University for Science and Technology of China, Hefei, Anhui, CHINA**

J. Wu, Z.P. Zhang

**Shanghai Institute of Ceramics, Shanghai, CHINA (Associated Institute)**

P.J. Li, J. Liao, Z.L. Xue, D.S. Yan, H. Yuan

**Universidad de Los Andes, Bogota, COLOMBIA**

M. Baquero Ruiz, C.A. Carrillo Montoya

**Technical University of Split, Split, CROATIA**

N. Godinovic, I. Puljak, I. Soric

**University of Split, Split, CROATIA**

Z. Antunovic, M. Dzelalija, K. Marasovic

**Institute Rudjer Boskovic, Zagreb, CROATIA**

V. Brigljevic, K. Kadija, S. Morovic, M. Planinic<sup>\*\*2</sup>

**University of Cyprus, Nicosia, CYPRUS**

R. Fereos, C. Nicolaou, A. Papadakis, F. Ptochos, P.A. Razis, D. Tsiakkouri, Z. Zinonos

**National Institute of Chemical Physics and Biophysics, Tallinn, ESTONIA**

A. Hektor, K. Isakar, M. Kadastik, K. Kannike, E. Lippmaa, M. Müntel, M. Raidal, L. Rebane, H. Valtna

**Laboratory of Advanced Energy Systems, Helsinki University of Technology, Espoo, FINLAND**

P.A. Aarnio

**Helsinki Institute of Physics, Helsinki, FINLAND**

S. Czellar, E. Ennabli, A. Heikkinen, J. Härkönen, V. Karimäki, R. Kinnunen, T. Lampén, K. Lassila-Perini, S. Lehti, T. Lindén, P.R. Luukka, S. Michal<sup>\*\*1</sup>, T. Mäenpää, J. Nystén, Y.S. Shah, E. Tuominen, J. Tuominiemi, E. Tuovinen, L. Wendland

**Lappeenranta University of Technology, Lappeenranta, FINLAND**

M. Iskanius, A. Korpela, G. Polese, T. Tuuva

**Laboratoire d'Annecy-le-Vieux de Physique des Particules, IN2P3-CNRS, Annecy-le-Vieux, FRANCE**

J.P. Guillaud, P. Nedelec, D. Sillou

**DSM/DAPNIA, CEA/Saclay, Gif-sur-Yvette, FRANCE**

M. Anfreville, E. Bougamont, P. Bredy, R. Chipaux, M. Dejardin, D. Denegri, J. Descamps, B. Fabbro, J.L. Faure, S. Ganjour, F.X. Gentit, A. Givernaud, P. Gras, G. Hamel de Monchenault, P. Jarry, F. Kircher, M.C. Lemaire<sup>\*\*3</sup>, B. Levesy<sup>\*\*1</sup>, E. Locci, J.P. Lottin, I. Mandjavidze, M. Mur, E. Pasquetto, A. Payn, J. Rander, J.M. Reymond, F. Rondeaux, A. Rosowsky, J.Y.A. Rousse, Z.H. Sun, P. Verrecchia

**Laboratoire Leprince-Ringuet, Ecole Polytechnique, IN2P3-CNRS, Palaiseau, FRANCE**

S. Baffioni, M. Bercher, U. Berthon, S. Bimbot, J. Bourotte, P. Busson, M. Cerutti, D. Chamont, C. Charlot, C. Collard, D. Decotigny, L. Dobrzynski, A.M. Gaillac, Y. Geerebaert, J. Gilly, M. Haguenauer, A. Karar, A. Mathieu, G. Milleret, P. Miné, P. Mora de Freitas, P. Paganini, J. Riou-Fougeras, T. Romanteau, I. Semeniouk, Y. Sirois, C. Thiebaut

**Institut Pluridisciplinaire Hubert Curien, IN2P3-CNRS - ULP, UHA Mulhouse, Strasbourg, FRANCE**

J.L. Agram, J. Andrea, J.D. Berst, D. Bloch, J.M. Brom, F. Didierjean, F. Drouhin<sup>\*\*1</sup>, J.C. Fontaine<sup>\*\*4</sup>, D. Gele, U. Goerlach<sup>\*\*5</sup>, P. Graehling, L. Gross<sup>\*\*1</sup>, L. Houchu, P. Juillot, A. Lounis<sup>\*\*5</sup>, C. Maazouzi, D. Mangeol, C. Olivetto, Y. Patois, T. Todorov<sup>\*\*1</sup>, P. Van Hove, D. Vintache

**Institut de Physique Nucléaire, IN2P3-CNRS, Université Claude Bernard Lyon 1, Villeurbanne, FRANCE**

M. Ageron, G. Baulieu, M. Bedjidian, J. Blaha, A. Bonnevaux, G. Boudoul<sup>\*\*1</sup>, E. Chabanat, E.C. Chabert, C. Combaret, D. Contardo<sup>\*\*1</sup>, R. Della Negra, P. Depasse, T. Dupasquier, H. El Mamouni, N. Estre, J. Fay, S. Gascon, G.T. Giacinti, N. Giraud, C. Girerd, R. Haroutunian, J.C. Ianigro, B. Ille, M. Lethuillier, N. Lumb<sup>\*\*1</sup>, H. Mathez, G. Maurelli, S. Perries, O. Ravat, E. Schibler, P. Verdier

**Institute of Physics Academy of Science, Tbilisi, GEORGIA**

V. Roinishvili

**RWTH, I. Physikalisches Institut, Aachen, GERMANY**

R. Adolphi, R. Brauer, W. Braunschweig, H. Esser, L. Feld, W. Karpinski, K. Klein, C. Kukulies, J. Olzem, A. Ostapchuk, D. Pandoulas, G. Pierschel, F. Raupach, S. Schael, G. Schwering, M. Thomas, M. Weber, B. Wittmer, M. Wlochal

**RWTH, III. Physikalisches Institut A, Aachen, GERMANY**

A. Adolf, P. Biallass, M. Bontenackels, M. Erdmann, H. Fesefeldt, T. Hebbeker, G. Hilgers, K. Hoepfner<sup>\*\*1</sup>, C. Hof, S. Kappler, M. Kirsch, P. Kreuzer, D. Lanske, A. Meyer, B. Philipps, H. Reithler, M. Sowa, H. Szczesny, D. Teyssier, O. Tsigenov

**RWTH, III. Physikalisches Institut B, Aachen, GERMANY**

F. Beissel, M. Davids, M. Duda, G. Flügge, T. Franke, M. Giffels, T. Hermanns, D. Heydhausen, S. Kasselmann, G. Kaussen, T. Kress, A. Linn, A. Nowack, M. Poettgens, O. Pooth, A. Stahl, A. Tigges, D. Tornier, M.H. Zoeller

**Deutsches Elektronen-Synchrotron, Hamburg, GERMANY**

U. Behrens, M. Ernst, A. Flossdorf, D. Hatton, B. Hegner, B. Lewendel, J. Mnich, C. Rosemann, C. Youngman, W.D. Zeuner<sup>\*\*1</sup>

**University of Hamburg, Hamburg, GERMANY**

F. Bechtel, E. Butz, G. Flucke, U. Holm, R. Klanner, U. Pein, N. Schirm, P. Schleper, G. Steinbrück, M. Stoye, R. Van Staa, K. Wick

**Institut für Experimentelle Kernphysik, Karlsruhe, GERMANY**

P. Blüm, V. Buege, A. Cakir<sup>\*\*6</sup>, W. De Boer, G. Dirkes, M. Fahrner, M. Feindt, U. Felzmann, M. Frey, A. Furgeri, I. Gebauer, F. Hartmann<sup>\*\*1</sup>, S. Heier, M. Heinrich, C. Jung, Y. Kemp, U. Kerzel, B. Ledermann, S. Mueller, Th. Müller, M. Niegel, O. Oberst, A. Oehler, T. Ortega Gomez, C. Piasecki, A. Poschlad, G. Quast, K. Rabbertz, A. Sabellek, C. Saout, A. Scheurer, D. Schieferdecker, F.P. Schilling, A. Schmidt, H.J. Simonis, A. Theel, A. Vest, W. Wagner, M. Weber, J. Weinelt, C. Weiser, J. Weng<sup>\*\*1</sup>, V. Zhukov<sup>\*\*7</sup>

**University of Athens, Athens, GREECE**

A. Kalogeropoulos, G. Karapostoli<sup>\*\*1</sup>, P. Katsas, M. Lebeau, A. Panagiotou, C. Papadimitropoulos

**Institute of Nuclear Physics "Demokritos", Attiki, GREECE**

G. Anagnostou, M. Barone, C. Filippidis, T. Geralis, K. Karafasoulis, A. Koimas, A. Kyriakis, S. Kyriazopoulou, D. Loukas, A. Markou, C. Markou, C. Mavrommatis, E. Petrakou, K. Theofilatos, G. Vermisoglou, A. Zachariadou

**University of Ioánnina, Ioánnina, GREECE**

I. Evangelou, P. Kokkas, N. Manthos, I. Papadopoulos, F.A. Triantis

**KFKI Research Institute for Particle and Nuclear Physics, Budapest, HUNGARY**

G. Bencze<sup>\*\*1</sup>, L. Boldizsar, G. Debreczeni, C. Hajdu<sup>\*\*1</sup>, D. Horvath<sup>\*\*8</sup>, P. Kovesarki, A. Laszlo, G. Odor, G. Patay, F. Sikler, N. Toth, G. Vesztergombi, P. Zalan

**Institute of Nuclear Research ATOMKI, Debrecen, HUNGARY**

J. Molnar

**University of Debrecen, Debrecen, HUNGARY**

N. Beni, A. Kapusi, G. Marian, B. Radics, P. Raics, Z. Szabo, Z. Szillasi, G. Zilizi

**Panjab University, Chandigarh, INDIA**

S. Bansal, H.S. Bawa, S.B. Beri, V. Bhandari, V. Bhatnagar, S. Gautam, P. Jindal, M. Kaur, R. Kaur, J.M. Kohli, A. Kumar, J.B. Singh

**University of Delhi, Delhi, INDIA**

S. Arora, S. Bhattacharya<sup>\*\*9</sup>, S. Chatterji, S. Chauhan, B.C. Choudhary, P. Gupta, M. Jha, K. Ranjan, R.K. Shivpuri, A.K. Srivastava

**Bhabha Atomic Research Centre, Mumbai, INDIA**

S. Borkar, R.K. Choudhury, V. Datar, M. Dixit, D. Dutta, M. Ghodgaonkar, S. Kailas, S.K. Kataria, S.K. Lalwani, V. Mishra, A.K. Mohanty, L. Pant, P. Shukla, P. Suggisetti, S. Suryanarayana, A. Topkar

**Tata Institute of Fundamental Research - EHEP, Mumbai, INDIA**

T. Aziz, S. Banerjee, S. Bose, S. Chendvankar, P.V. Deshpande, M. Guchait<sup>\*\*10</sup>, A. Gurtu, M. Maity<sup>\*\*11</sup>, G. Majumder, K. Mazumdar, A. Nayak, M.R. Patil, S. Sharma, K. Sudhakar

**Tata Institute of Fundamental Research - HECR, Mumbai, INDIA**

B.S. Acharya, S. Banerjee, S. Bheesette, S. Dugad, S.D. Kalmani, V.R. Lakkireddi, N.K. Mondal, N. Panyam, P. Verma

**Institute for Studies in Theoretical Physics & Mathematics (IPM), Tehran, IRAN**

M. Arabgol, H. Arfaei, M. Hashemi, M. Mohammadi, M. Mohammadi Najafabadi, A. Moshaii, S. Paktinat Mehdiabadi

**University College Dublin, Dublin, IRELAND**

M. Felcini<sup>\*\*1</sup>, M. Grunewald

**Università di Bari, Politecnico di Bari e Sezione dell' INFN, Bari, ITALY**

M. Abbrescia, L. Barbone, M.A. Borgia, A. Colaleo<sup>\*\*1</sup>, D. Creanza, N. De Filippis, M. De Palma, G. De Robertis, G. Donvito, L. Fiore, D. Giordano, G. Iaselli, F. Loddo, G. Maggi, M. Maggi, N. Manna, B. Marangelli, M.S. Mennea, S. My, S. Natali, S. Nuzzo, G. Pugliese, V. Radicci, A. Ranieri, F. Romano, G. Roselli, G. Selvaggi, L. Silvestris<sup>\*\*1</sup>, P. Tempesta, R. Trentadue, S. Tupputi, G. Zito

**Università di Bologna e Sezione dell' INFN, Bologna, ITALY**

G. Abbiendi, W. Bacchi, C. Battilana, A. Benvenuti, D. Bonacorsi, S. Braibant-Giacomelli, P. Capiluppi, A. Castro, F.R. Cavallo, C. Ciocca, G. Codispoti, I. D'Antone, G.M. Dallavalle, F. Fabbri, A. Fanfani, P. Giacomelli<sup>\*\*12</sup>, C. Grandi, M. Guerzoni, L. Guiducci, C. Latini, S. Marcellini, G. Masetti, A. Montanari, F. Navarra, F. Odorici, A. Perrotta, A. Rossi, T. Rovelli, G. Siroli, R. Travaglini, G.P. Veronese

**Università di Catania e Sezione dell' INFN, Catania, ITALY**

S. Albergo, V. Bellini, M. Chiorboli, S. Costa, M. Galanti, R. Potenza, C. Sutera, A. Tricomi, C. Tuve

**Università di Firenze e Sezione dell' INFN, Firenze, ITALY**

G. Ciruolo, V. Ciulli, C. Civinini, R. D'Alessandro, E. Focardi, C. Genta, G. Landi, P. Lenzi, A. Macchiolo, N. Magini, F. Manolescu, C. Marchettini, L. Masetti, S. Mersi, M. Meschini, V. Noce, S. Paoletti, G. Parrini, M. Sani, G. Sguazzoni, A. Viciani

**Laboratori Nazionali di Frascati dell'INFN, Frascati, ITALY**

L. Benussi, M. Bertani, S. Bianco, M. Caponero, D. Colonna<sup>\*\*1</sup>, F. Fabbri, F. Felli, A. La Monaca, M. Pallotta, A. Paolozzi, C. Pucci, G. Saviano

**Università di Genova e Sezione dell' INFN, Genova, ITALY**

M. Bozzo, P. Fabbriatore, S. Farinon, F. Ferro, M. Greco

**Laboratori Nazionali di Legnaro dell' INFN, Legnaro, ITALY (Associated Institute)**

S. Badoer, L. Berti, M. Biasotto, S. Fantinel, E. Frizziero, U. Gastaldi, M. Gulmini<sup>\*\*1</sup>, F. Lelli, G. Maron, A. Petrucci, S. Squizzato, N. Toniolo, S. Traldi

**Istituto Nazionale di Fisica Nucleare e Università Degli Studi Milano-Bicocca, Milano, ITALY**

L. Carbone, G. Cattaneo, G.B. Cerati, P. D'Angelo, F. De Guio, A. De Min, P. Dini, M. Dominoni, F.M. Farina, F. Ferri, A. Ghezzi, P. Govoni, R. Leporini, S. Magni, M. Malberti, S. Malvezzi, S. Marelli, D. Menasce, V. Miccio, L. Moroni, P. Negri, M. Paganoni, D. Pedrini, A. Pullia, S. Ragazzi, N. Redaelli, M. Rovere, L. Sala, S. Sala, R. Salerno, T. Tabarelli de Fatis, V. Tancini, S. Viganò

**Istituto Nazionale di Fisica Nucleare de Napoli (INFN), Napoli, ITALY**

G. Comunale, F. Fabozzi, D. Lomidze, S. Mele, P. Paolucci, D. Piccolo, C. Sciacca

**Università di Padova e Sezione dell' INFN, Padova, ITALY**

P. Azzi, N. Bacchetta<sup>\*\*1</sup>, M. Bellato, M. Benettoni, D. Bisello, E. Borsato, A. Candelori, P. Checchia, E. Conti, F. Dal Corso, M. De Mattia, A. Dorigo, T. Dorigo, U. Dosselli, V. Drollinger, F. Gasparini, U. Gasparini, P. Giubileo, F. Gonella, A. Kaminskiy, S. Karaevskii, V. Khomenkov, S. Lacaparra, I. Lippi, M. Loreti, O. Lytovchenko, S. Mattiazzo, M. Mazzucato, A.T. Meneguzzo, M. Michelotto, F. Montecassiano<sup>\*\*1</sup>, M. Nigro, D. Pantano, A. Parenti, M. Passaseo, M. Pegoraro, G. Rampazzo, S. Reznikov, P. Ronchese, M. Sgaravatto, E. Torassa, S. Vanini, S. Ventura, M. Verlato, M. Zanetti, P. Zotto, G. Zumerle

**Università di Pavia e Sezione dell' INFN, Pavia, ITALY**

G. Belli, U. Berzano, C. De Vecchi, A. Grelli, M.M. Necchi, D. Pagano, S.P. Ratti, C. Riccardi, M. Rossella, G. Sani, P. Torre, P. Vitulo, C. Viviani

**Università di Perugia e Sezione dell' INFN, Perugia, ITALY**

F. Ambroglini, E. Babucci, D. Benedetti, M. Biasini, G.M. Bilei<sup>\*\*1</sup>, B. Caponeri, B. Checcucci, L. Fanò, M. Giorgi, P. Lariccia, G. Mantovani, F. Moscatelli, D. Passeri, P. Placidi, V. Postolache, A. Santocchia, L. Servoli, D. Spiga, D. Tonoiu

**Università di Pisa, Scuola Normale Superiore e Sezione dell' INFN, Pisa, ITALY**

P. Azzurri, G. Bagliesi, A. Basti, L. Benucci, J. Bernardini, T. Boccali, A. Bocci, L. Borrello, F. Bosi, F. Calzolari, A. Carboni, R. Castaldi, C. Cerri, A.S. Cucoanes, R. Dell'Orso, S. Dutta, C. Ferrazza, F. Fiori, L. Foà, S. Gennai<sup>\*\*13</sup>, A. Giassi, D. Kartashov, F. Ligabue, S. Linari, T. Lomtadze, G.A. Lungu, B. Mangano, G. Martinelli, M. Massa, A. Messineo, A. Moggi, F. Palla, F. Palmonari, G. Petrucciani, F. Raffaelli, A. Rizzi, G. Sanguinetti, S. Sarkar, G. Segneri, D. Sentenac, A.T. Serban, A. Slav, P. Spagnolo, R. Tenchini, G. Tonelli<sup>\*\*1</sup>, A. Venturi, P.G. Verdini, M. Vos

**Università di Roma I e Sezione dell' INFN, Roma, ITALY**

S. Baccaro<sup>\*\*14</sup>, L. Barone, A. Bartoloni, C. Bulfon, F. Cavallari, S. Costantini, I. Dafinei, D. Del Re,

M. Diemoz, C. Gargiulo, E. Longo, P. Meridiani, G. Organtini, A. Palma, R. Paramatti, S. Rahatlou, C. Rovelli, F. Safai Tehrani, F. Santanastasio, V. Valente

**Università di Torino e Sezione dell' INFN, Torino, ITALY**

R. Arcidiacono, S. Argiro, R. Bellan, C. Biino, S. Bolognesi, N. Cartiglia, G. Cerminara, M. Cordero, M. Costa, D. Dattola<sup>\*\*1</sup>, G. Dellacasa, N. Demaria, C. Mariotti, S. Maselli, P. Mereu, E. Migliore, V. Monaco, M. Nervo, M.M. Obertino, N. Pastrone, G. Petrillo, A. Romero, R. Sacchi, A. Staiano, P.P. Trapani

**Università di Trieste e Sezione dell' INFN, Trieste, ITALY**

S. Belforte, F. Cossutti, G. Della Ricca, B. Gobbo, C. Kavka

**Kyungpook National University, Daegu, KOREA**

D.H. Kim, E.J. Kim, J.C. Kim, W.Y. Kim, S.K. Oh, S.R. Ro, D.C. Son

**Konkuk University, Seoul, KOREA**

S.Y. Jung, J.T. Rhee

**Korea University, Seoul, KOREA**

B.S. Hong, S.J. Hong, K.S. Lee, D.H. Moon, S.K. Park, K.S. Sim

**Sungkyunkwan University, Suwon, KOREA**

J.H. Goh

**Centro de Investigacion y de Estudios Avanzados del IPN, Mexico City, MEXICO**

H. Castilla Valdez, I. Pedraza, A. Sanchez Hernandez

**Universidad Iberoamericana, Mexico City, MEXICO**

S. Carrillo Moreno

**Benemerita Universidad Autonoma de Puebla, Puebla, MEXICO**

H.A. Salazar Ibarquen

**Universidad Autonoma de San Luis Potosi, San Luis Potosi, MEXICO**

A. Morelos Pineda

**Technische Universiteit Eindhoven, Eindhoven, NETHERLANDS (Associated Institute)**

A. Aerts, P. Van der Stok, A. Wijnant

**University of Auckland, Auckland, NEW ZEALAND**

R.N.C. Gray, D. Krofcheck

**University of Canterbury, Christchurch, NEW ZEALAND**

A.J. Bell, N. Bernardino Rodrigues, P.H. Butler, S. Churchwell, J.C. Williams

**National Centre for Physics, Quaid-I-Azam University, Islamabad, PAKISTAN**

Z. Aftab, N. Ahmad, U. Ahmad, I. Ahmed, W. Ahmed, M.I. Asghar, S. Asghar, M.I.M. Awan, G. Dad, M. Hafeez, H.R. Hoorani, I. Hussain, N. Hussain, M. Iftikhar, M.S. Khan, T. Khurshid, K. Mehmood, S. Muhammad, M.T. Murtaza, A. Osman, F. Shahzad, H. Shahzad, M.U.I. Sheikh, S.A. Shiekh, T. Solajja, A.R. Zafar

**National University of Sciences And Technology, Rawalpindi Cantt, PAKISTAN (Associated Institute)**

M.K.H. Ahmad, A. Ali, O.I. Alvi, A. Bashir, A.M. Jan, A. Kamal, F. Khan, M. Saeed, S. Tanwir, M.A. Zafar

**Institute of Nuclear Physics, Polish Academy of Sciences, Cracow, POLAND**



J. Blocki, A. Cyz, E. Gladysz-Dziadus, S. Mikocki, J. Turnau, Z. Wlodarczyk<sup>\*\*15</sup>, P. Zychowski

**Institute of Experimental Physics, Warsaw, POLAND**

K. Bunkowski, H. Czyrkowski, R. Dabrowski, W. Dominik, K. Doroba, A. Kalinowski, M. Konecki, J. Krolkowski, I.M. Kudla, M. Pietrusinski, K. Pozniak<sup>\*\*16</sup>, W. Zabolotny<sup>\*\*16</sup>, P. Zych

**Soltan Institute for Nuclear Studies, Warsaw, POLAND**

M. Bluj, R. Gokieli, M. Górski, L. Gosciło, K. Nawrocki, P. Traczyk, G. Wrochna, P. Zalewski

**Warsaw University of Technology, Institute of Electronic Systems, Warsaw, POLAND (Associated Institute)**

R. Romaniuk

**Laboratório de Instrumentação e Física Experimental de Partículas, Lisboa, PORTUGAL**

R. Alemany-Fernandez, C. Almeida, N. Almeida, A. Araujo Trindade, P. Bordalo, R. Bugalho De Moura, P. Da Silva Rodrigues, A. David Tinoco Mendes, M. Gallinaro, J. Gomes, M. Husejko, P. Ingenito, A. Jain, M. Kazana, P. Musella, S. Ramos, J. Rasteiro Da Silva, P.Q. Ribeiro, M. Santos, J. Semiao, P. Silva, I. Teixeira, J.P. Teixeira, J. Varela<sup>\*\*1</sup>, N. Vaz Cardoso

**Joint Institute for Nuclear Research, Dubna, RUSSIA**

I. Altynov, K. Babich, D. Bardin, I. Belotelov, P. Bunin, S. Chesnevskaya, V. Elsha, Y. Ershov, A. Evdokimov, I. Filozova, M. Finger, M. Finger, A. Golunov, I. Golutvin, N. Gorbounov, O. Gudkov, V. Kalagin, A. Kamenev, V. Karjavin, S. Khabarov, V. Khabarov, Y. Kiryushin, V. Konoplyanikov, V. Korenkov, A. Kozlov, A. Kurenkov, A. Lanev, V. Lysiakov, A. Malakhov, I. Melnitchenko, V.V. Mitsyn, K. Moisenz, P. Moisenz, S. Movchan, E. Nikonov, M. Nozdrin, D. Oleynik, V. Palichik, A. Pavlov, V. Perelygin, A. Petrosyan, A. Radov, E. Rogalev, V. Samsonov, M. Savina, R. Semenov, B. Shestov, S. Shmatov, S. Shulha, V. Slunckova, V. Smirnov, D. Smolin, A. Tcheremoukhine, O. Teryaev, E. Tikhonenko, S. Vassiliev, A. Vishnevskiy, A. Volodko, N. Zamiatin, A. Zarubin, E. Zubarev

**Petersburg Nuclear Physics Institute, Gatchina (St Petersburg), RUSSIA**

N. Bondar, Y. Gavrikov, G. Gavrilo, V. Golovtsov, Y. Ivanov, V. Kim, V. Kozlov, V. Lebedev, A. Lobodenko, G. Makarenkov, G. Obrant, E. Orishchin, Y. Shcheglov, A. Shchetkovskiy, A. Shevel, V. Sknar, V. Skorobogatov, I. Smirnov, V. Sulimov, V. Tarakanov, L. Uvarov, G. Velichko, S. Volkov, A. Vorobyev

**High Temperature Technology Center of Research & Development Institute of Power Engineering (HTTC RDIPE), Moscow, RUSSIA (Associated Institute)**

D. Chmelev, D. Druzhkin, A. Ivanov, V. Kudinov, O. Logatchev, S. Onishchenko, A. Orlov, V. Sakharov, V. Smetannikov, A. Tikhomirov, S. Zavodthikov

**Institute for Nuclear Research, Moscow, RUSSIA**

Yu. Andreev, A. Anisimov, S. Gninenko, N. Golubev, D. Gorbunov, A. Ivashkin, M. Kirsanov, A. Kovzelev, N. Krasnikov, V. Matveev, A. Pashenkov, A. Pastyak, V.E. Postoev, A. Sadovskiy, A. Solovey, A. Solovey, D. Soloviev, A. Toropin, S. Troitsky

**Institute for Theoretical and Experimental Physics, Moscow, RUSSIA**

V. Gavrilov, N. Ilina, V. Kaftanov, I. Kiselevich, V. Kolosov, M. Kossov<sup>\*\*1</sup>, A. Krokhotin, S. Kuleshov, A. Oulianov, A. Pozdnyakov, G. Safronov, S. Semenov, V. Stolin, E. Vlasov<sup>\*\*1</sup>, V. Zaytsev

**Moscow State University, Moscow, RUSSIA**

E. Boos, M. Dubinin<sup>\*\*3</sup>, L. Dudko, A. Ershov, G. Eyyubova, R. Gloukhov, A. Gribushin, V. Ilyin, V. Klyukhin<sup>\*\*1</sup>, O. Kodolova, N.A. Kruglov, A. Kryukov, I. Lokhtin, V. Mikhaylin, S. Petrushanko, L. Sarycheva, V. Savrin, L. Shamardin, A. Sherstnev, A. Snigirev, K. Teplov, I. Vardanyan

**P.N. Lebedev Physical Institute, Moscow, RUSSIA**

E. Devitsin, A.M. Fomenko, N. Konovalova, V. Kozlov, A.I. Lebedev, N. Lvova, S. Potashov, S.V. Rusakov, A. Terkulov

**State Research Center of Russian Federation - Institute for High Energy Physics, Protvino, RUSSIA**

V. Abramov, S. Akimenko, A. Artamonov, A. Ashimova, I. Azhgirey, S. Bitioukov, O. Chikilev, K. Datsko, A. Filine, A. Godizov, P. Goncharov, V. Grishin, A. Inyakin<sup>\*\*17</sup>, V. Kachanov, A. Kalinin, A. Khmelnikov, D. Konstantinov, A. Korablev, E. Kozlovskiy, V. Krychkine, A. Levine, I. Lobov, V. Lukanin, Y. Mel'nik, V. Molchanov, V. Petrov, V. Petukhov, V. Pikalov, P. Ponomarev, A. Ryazanov, R. Ryutin, V. Shelikhov, V. Skvortsov, S. Slabospitsky, O. Soumaneev, O. Sysoeva, A. Sytine, V. Talov, L. Tourtchanovitch, S. Troshin, N. Tyurin, A. Uzunian, A. Volkov, S. Zelepoukine<sup>\*\*18</sup>

**Electron National Research Institute, St Petersburg, RUSSIA (Associated Institute)**

V. Lukyanov, G. Mamaeva, Z. Prilutskaya, I. Rumyantsev, S. Sokha, S. Tataurschikov, I. Vasilyev

**Vinca Institute of Nuclear Sciences, Belgrade, SERBIA**

P. Adzic, D. Krpic<sup>\*\*19</sup>, D. Maletic, P. Milenovic, J. Puzovic<sup>\*\*19</sup>, N. Smiljkovic<sup>\*\*1</sup>, M. Zupan

**Centro de Investigaciones Energeticas Medioambientales y Tecnologicas, Madrid, SPAIN**

E. Aguayo Navarrete, M. Aguilar-Benitez, J. Alberdi, J. Alcaraz Maestre, M. Aldaya Martin, P. Arce<sup>\*\*1</sup>, J.M. Barcala, C. Burgos Lazaro, J. Caballero Bejar, E. Calvo, M. Cardenas Montes, M. Cepeda, M. Cerrada, M. Chamizo Llatas, F. Clemente, N. Colino, M. Daniel, B. De La Cruz, A. Delgado Peris, C. Fernandez Bedoya, A. Ferrando, M.C. Fouz, P. Garcia-Abia, O. Gonzalez Lopez, J.M. Hernandez, M.I. Josa, J.M. Luque, J. Marin, G. Merino, A. Molinero, J.J. Navarrete, J.C. Oller, E. Perez Calle, L. Romero, C. Villanueva Munoz, C. Willmott, C. Yuste

**Universidad Autónoma de Madrid, Madrid, SPAIN**

C. Albajar, J.F. de Trocóniz, E. Delmeire, I. Jimenez, R.F. Teixeira

**Universidad de Oviedo, Oviedo, SPAIN**

J. Cuevas, J. Lopez-Garcia, H. Naves Sordo, J.M. Vizán Garcia

**Instituto de Física de Cantabria (IFCA), CSIC-Universidad de Cantabria, Santander, SPAIN**

I.J. Cabrillo, A. Calderon, D. Cano Fernandez, I. Diaz Merino, M. Fernandez, J. Fernandez Menendez<sup>\*\*20</sup>, L.A. Garcia Moral, G. Gomez, I. Gonzalez Caballero, J. Gonzalez Sanchez, R. Gonzalez Suarez, A. Lopez Virto, J. Marco, R. Marco, C. Martinez Rivero, P. Martinez Ruiz del Arbol, F. Matorras, A. Patino Revuelta<sup>\*\*1</sup>, T. Rodrigo, D. Rodriguez Gonzalez, A. Ruiz Jimeno, L. Scodellaro, M. Sobron Sanudo, I. Vila, R. Vilar Cortabitarte

**CERN, European Organization for Nuclear Research, Geneva, SWITZERLAND**

D. Abbaneo, S.M. Abbas<sup>\*\*21</sup>, I. Ahmed<sup>\*\*21</sup>, M.I. Akhtar<sup>\*\*21</sup>, S. Akhtar, M.E. Alonso Rodriguez, N. Amapane, B. Araujo Meleiro, S. Ashby, P. Aspell, E. Auffray, M. Axer, A. Ball, N. Bangert, D. Barney, S. Beauceron, F. Beaudette<sup>\*\*22</sup>, W. Bialas, C. Bloch, P. Bloch, S. Bonacini, M. Bosteels, V. Boyer, A. Branson, A.M. Brett, H. Breuker, R. Bruneliere, O. Buchmuller, D. Campi, T. Camporesi, E. Cano, A. Cattai, R. Chierici, T. Christiansen, S. Cittolin, E. Corrin, M. Corvo, B. Curé, C. D'Ambrosio, D. D'Enterria, A. De Roeck, C. Delaere, D. Delikaris, M. Della Negra, L.M. Edera, A. Elliott-Peisert, M. Eppard, F. Fanzago, R. Folch, S. Fratianni, W. Funk, A. Gaddi, J.V. Galan Chiner, M. Gastal, J.C. Gayde, H. Gerwig, K. Gill, A.S. Giolo-Nicollerat, F. Glege, R. Gomez-Reino Garrido, R. Goudard, P. Gutierrez Llamas, E. Gutierrez Mlot, J. Gutleber, M. Hansen, J. Harvey, A. Hervé, H.F. Hoffmann, A. Holzner, A. Honma, D. Hufnagel, M. Huhtinen, G. Iles, V. Innocente, W. Jank, P. Janot, K. Kloukinas, C. Lasseur, P. Lecoq, C. Leonidopoulos, M. Letheren, L. Linssen, C. Ljuslin, R. Loos, J.A. Lopez Perez, C. Lourenco, G. Magazzu, L. Malgeri, M. Mannelli, A. Marchioro, F. Meijers, E. Meschi, L. Mirabito, R. Moser, M. Mulders, J. Nash, R.A. Ofierzynski, A. Oh, P. Olbrechts, A. Onnela, L. Orsini, J.A. Osborne, I. Pal, P. Palau Pellicer, G. Papotti, G. Passardi, B. Perea Solano, G. Perinic, P. Petagna, A. Petrilli, A. Pfeiffer, M. Pimiä, R. Pintus, M. Pioppi, A. Placci, H. Postema, R. Principe, J. Puerta Pelayo, A. Racz, R. Ranieri, J. Rehn, S. Reynaud, D. Ricci,

M. Risoldi, P. Rodrigues Simoes Moreira, G. Rolandi, F.J. Ronga, P. Rumerio, V. Ryjov, H. Sakulin, D. Samyn, L.C. Santos Amaral, E. Sarkisyan-Grinbaum, P. Schieferdecker, W.D. Schlatter, C. Schwick, C. Schäfer, I. Segoni, A. Sharma, P. Siegrist, N. Sinanis, P. Sphicas<sup>\*\*23</sup>, M. Spiropulu, F. Szoncsó, O. Teller, P. Tropea, J. Troska, E. Tsesmelis, D. Tsirigkas, A. Tsirou, M. Tytgat<sup>\*\*24</sup>, D. Ungaro, M. Vander Donckt, F. Vasey, M. Vazquez Acosta, L. Veillet, P. Vichoudis, P. Wertelaers, M. Wilhelmsson, I.M. Willers, A. Zabi<sup>\*\*25</sup>

**Paul Scherrer Institut, Villigen, SWITZERLAND**

W. Bertl, K. Deiters, W. Erdmann, D. Feichtinger, K. Gabathuler, R. Horisberger, Q. Ingram, H.C. Kaestli, D. Kotlinski, S. König, D. Renker, T. Rohe

**Institute for Particle Physics, ETH Zurich, Zurich, SWITZERLAND**

B. Betev, L. Caminada, Z. Chen, S. Dambach<sup>\*\*26</sup>, G. Davatz, V. Delachenal<sup>\*\*1</sup>, G. Dissertori, M. Dittmar, L. Djambazov, C. Eggel<sup>\*\*26</sup>, J. Ehlers, R. Eichler, G. Faber, K. Freudenreich, J.F. Fuchs<sup>\*\*1</sup>, C. Grab, W. Hintz, U. Langenegger, P. Lecomte, P.D. Luckey, W. Luster, J.D. Maillefaud<sup>\*\*1</sup>, B. Meier, F. Moortgat, A. Nardulli, F. Nessi-Tedaldi, L. Pape, F. Pauss, T. Punz, U. Röser, D. Schinzel, A. Sourkov<sup>\*\*27</sup>, A. Starodumov<sup>\*\*28</sup>, F. Stöckli, H. Suter, L. Tauscher, P. Trüb<sup>\*\*26</sup>, J. Ulbricht, G. Viertel, H.P. von Gunten, M. Wensveen<sup>\*\*1</sup>

**Universität Zürich, Zürich, SWITZERLAND**

E. Alagoz, C. AMSLER, V. Chiochia, C. Regenfus, P. Robmann, T. Rommerskirchen, T. Speer, S. Steiner, L. Wilke

**National Central University, Chung-Li, TAIWAN**

S. Blyth, Y.H. Chang, E.A. Chen, A. Go, C.C. Hung, C.M. Kuo, W. Lin

**National Taiwan University (NTU), Taipei, TAIWAN**

P. Chang, Y. Chao, K.F. Chen, Z. Gao<sup>\*\*1</sup>, Y. Hsiung, Y.J. Lei, J. Schumann, J.G. Shiu, K. Ueno, Y. Velikzhanin, P. Yeh

**Cukurova University, Adana, TURKEY**

S. Aydin, M.N. Bakirci, S. Cerci, I. Dumanoglu, S. Erturk<sup>\*\*29</sup>, E. Eskut, A. Kayis Topaksu, H. Kisoglu, P. Kurt, H. Ozkurt, A. Polatöz, K. Sogut<sup>\*\*30</sup>, H. Topakli, M. Vergili, G. Önengüt

**Middle East Technical University, Physics Department, Ankara, TURKEY**

H. Gamsizkan, A.M. Guler, C. Ozkan, S. Sekmen, M. Serin-Zeyrek, R. Sever, E. Yazgan, M. Zeyrek

**Bogaziçi University, Department of Physics, Istanbul, TURKEY**

K. Cankocak<sup>\*\*31</sup>, M. Deliomeroglu, D. Demir<sup>\*\*6</sup>, E. Gülmez, E. Isiksal<sup>\*\*32</sup>, M. Kaya<sup>\*\*33</sup>, O. Kaya<sup>\*\*33</sup>, S. Ozkorucuklu<sup>\*\*34</sup>, N. Sonmez<sup>\*\*35</sup>

**Institute of Single Crystals of National Academy of Science, Kharkov, UKRAINE**

B. Grinev, V. Lyubynskiy, V. Senchyshyn

**National Scientific Center, Kharkov Institute of Physics and Technology, Kharkov, UKRAINE**

L. Levchuk, A. Nemashkalo, D. Soroka, S. Zub

**Centre for Complex Cooperative Systems, University of the West of England, Bristol, UNITED KINGDOM (Associated Institute)**

A. Anjum, N. Baker, F. Estrella<sup>\*\*1</sup>, S. Gaspard, M. Hassan, T. Hauer, D. Manset, R. McClatchey, M. Odeh, D. Rogulin, J. Shamdasani, A. Solomonides

**University of Bristol, Bristol, UNITED KINGDOM**

J.J. Brooke, R. Croft, D. Cussans, D. Evans, N. Grant, M. Hansen, G.P. Heath, H.F. Heath, C. Hill, B. Huckvale, J. Jackson, C. Lynch, C.K. Mackay, S. Metson, D.M. Newbold<sup>\*\*36</sup>, K. Nirunpong, V.J. Smith, R.J. Tapper, R. Walton

**Rutherford Appleton Laboratory, Didcot, UNITED KINGDOM**

K.W. Bell, R.M. Brown, B. Camanzi, D.J.A. Cockerill, J. Cole, J.A. Coughlan, P.S. Flower, P. Ford, V.B. Francis, M. French, A. Gay, J. Greenhalgh, R. Halsall, J. Hill, L. Jones, B.W. Kennedy, L. Lintern, Q. Morrissey, P. Murray, S. Quinton, J. Salisbury, C. Shepherd-Themistocleous, B. Smith, M. Sproston, R. Stephenson, S. Taghavirad, I.R. Tomalin, J. Williams

**Imperial College, University of London, London, UNITED KINGDOM**

F. Arteche, R. Bainbridge, G. Barber, P. Barrillon, R. Beuselinck, F. Blekman, D. Britton, D. Colling, N. Cripps, J.A. Crosse, G. Daskalakis, G. Davies, S. Dris<sup>\*\*1</sup>, C. Foudas, J. Fulcher, D. Futyan, S. Greder, G. Hall<sup>\*\*1</sup>, J. Hays, J. Jones, J. Leaver, B.C. MacEvoy, A. Nikitenko<sup>\*\*28</sup>, M. Noy, A. Papageorgiou, M. Pesaresi, K. Petridis, D.M. Raymond, A. Rose, M.J. Ryan, C. Seez, P. Sharp<sup>\*\*1</sup>, G. Sidiropoulos, M. Stettler<sup>\*\*1</sup>, A. Tapper, C. Timlin, T. Virdee<sup>\*\*1</sup>, S. Wakefield, M. Wingham, Y. Zhang, O. Zorba

**Brunel University, Uxbridge, UNITED KINGDOM**

C. Da Via, I. Goitom, P.R. Hobson, P. Kyberd, R. Lopes, C. Munro, J. Nebrensky, I. Reid, C. Siamitros, R. Taylor, L. Teodorescu, S.J. Watts, I. Yaselli

**Boston University, Boston, Massachusetts, USA**

E. Hazen, A.H. Hering, A. Heister, D. Lazic, D. Osborne, J. Rohlf, J. St. John, L. Sulak, S. Wu

**Brown University, Providence, Rhode Island, USA**

T. Bose, L. Christofek, D. Cutts, S. Esen, R. Hooper, G. Landsberg, M. Narain, D. Nguyen, K.V. Tsang

**University of California, Davis, Davis, California, USA**

R. Breedon, M. Case, M. Chertok, J. Conway, P.T. Cox, R. Erbacher, J. Gunion, B. Holbrook, W. Ko, A. Kopecky, R. Lander, A. Lister, S. Maruyama, D. Pellett, J. Smith, A. Soha, M. Tripathi, R. Vasquez Sierra, R. Vogt

**University of California, Los Angeles, Los Angeles, California, USA**

V. Andreev, K. Arisaka, D. Cline, R. Cousins, S. Erhan<sup>\*\*1</sup>, J. Hauser, M. Ignatenko, S. Ji, B. Lisowski, D. Matlock, C. Matthey, B. Mohr, J. Mumford, S. Otwinowski, G. Rakness, P. Schlein, Y. Shi, J. Tucker, V. Valuev, R. Wallny, H.G. Wang, X. Yang, Y. Zheng

**University of California, Riverside, Riverside, California, USA**

J. Babb, R. Clare, J.A. Ellison, D. Fortin, J.W. Gary, M. Giunta<sup>\*\*1</sup>, G. Hanson, G.Y. Jeng, S.C. Kao, H. Liu, O.R. Long, A. Luthra, G. Pasztor<sup>\*\*37</sup>, A. Satpathy, B.C. Shen, R. Stringer, W. Strossman, V. Sytnik, R. Wilken, S. Wimpenny

**University of California, San Diego, La Jolla, California, USA**

J.G. Branson, E. Dusinberre, M.R. Farsian, R. Kelley, M. Lebourgeois, J. Letts, E. Lipeles, D. MacFarlane, T. Martin, M. Mojaver, M. Norman, H.P. Paar, H. Pi, M. Pieri, A. Rana, V. Sharma, S. Simon, A. White, F. Würthwein, A. Yagil

**University of California, Santa Barbara, Santa Barbara, California, USA**

A. Affolder, C. Campagnari, M. D'Alfonso, A. Dierlamm, J. Garberson, J. Incandela, P. Kalavase, S.A. Koay, D. Kovalskyi, V. Krutelyov, S. Kyre, J. Lamb, J. Ribnik, J. Richman, D. Stuart, J.R. Vlimant, D. White, M. Witherell

**California Institute of Technology, Pasadena, California, USA**

T. Azim<sup>\*\*38</sup>, A. Bornheim, J. Bunn, J. Chen, G. Denis, P. Galvez, M. Gataullin, E. Hughes, Y. Kuznetsova, T. Lee, I. Legrand, V. Litvine, Y. Ma, R. Mao, D. Nae, I. Narsky, H.B. Newman, T. Orimoto, S. Ravot, C. Rogan, S. Shevchenko, C. Steenberg, X. Su, M. Thomas, V. Timciuc, F. van Lingen, J. Veverka, B.R. Voicu<sup>\*\*1</sup>, A. Weinstein, R. Wilkinson, Y. Xia, Y. Yang, L.Y. Zhang, K. Zhu, R.Y. Zhu

**Carnegie Mellon University, Pittsburgh, Pennsylvania, USA**

R. Carroll, T. Ferguson, M. Paulini, J. Russ, N. Terentyev, H. Vogel, I. Vorobiev

**University of Colorado at Boulder, Boulder, Colorado, USA**

M. Bunce, J.P. Cumalat, M.E. Dinardo, B.R. Drell, W.T. Ford, B. Heyburn, D. Johnson, U. Nauenberg, K. Stenson, S.R. Wagner

**Cornell University, Ithaca, NY, USA**

L. Agostino<sup>\*\*1</sup>, J. Alexander, D. Cassel, S. Das, J.E. Duboscq, L.K. Gibbons, B. Heltsley, J. Hunt, C.D. Jones, V. Kuznetsov, H. Li, H. Mahlke-Krueger, J.R. Patterson, D. Riley, A. Ryd, W. Sun, J. Thom, J. Vaughan, P. Wittich

**Fairfield University, Fairfield, Connecticut, USA**

C.P. Beetz, G. Cirino, V. Podrasky, C. Sanzeni, D. Winn

**Fermi National Accelerator Laboratory, Batavia, Illinois, USA**

S. Abdullin<sup>\*\*28</sup>, M.A. Afaq<sup>\*\*1</sup>, M. Albrow, G. Apollinari, M. Atac, W. Badgett, J.A. Bakken, B. Baldin, L.A.T. Bauerdick, A. Baumbaugh, J. Berryhill, P.C. Bhat, M. Binkley, I. Bloch, F. Borcharding, K. Burkett, J.N. Butler, H.W.K. Cheung, G. Chevenier<sup>\*\*1</sup>, I. Churin, S. Cihangir, W. Dagenhart, M. Demarteau, D. Dykstra, D.P. Eartly, J.E. Elias, V.D. Elvira, D. Evans, I. Fisk, J. Freeman, P. Gartung, F.J.M. Geurts, L. Giacchetti, D.A. Glenzinski, E. Gottschalk, D. Green, Y. Guo, O. Gutsche, A. Hahn, J. Hanlon, R.M. Harris, A. Heavey, T. Hesselroth, S.L. Holm, B. Holzman, S. Iqbal, E. James, H. Jensen, M. Johnson, U. Joshi, B. Klima, S. Kossiakov, J. Kowalkowski, T. Kramer, S. Kwan, E. La Vallie, M. Larwill, C.M. Lei, S. Los, L. Lueking, P. Lukens, G. Lukhanin, S. Lusin<sup>\*\*1</sup>, K. Maeshima, D. Mason, P. McBride, T. Miao, S. Moccia, S.J. Murray, C. Noeding, V. O'Dell, M. Paterno, D. Petravick, R. Pordes, O. Prokofyev, V. Rasmislovich, N. Ratnikova, A. Ronzhin, V. Sekhri, E. Sexton-Kennedy, I. Sfiligoi, T. Shaw, D. Skow, R.P. Smith, W.J. Spalding, L. Spiegel, M. Stavrianakou, G. Stiehr, A.L. Stone, I. Suzuki, P. Tan, W. Tanenbaum, S. Tkaczyk<sup>\*\*1</sup>, L. Uplegger, S. Veseli, R. Vidal, H. Wenzel, J. Whitmore, W.M. Wu, Y. Wu, J. Yarba, F. Yumiceva, J.C. Yun, A. Zatzerklyany, J.K. Zimmerman

**University of Florida, Gainesville, Florida, USA**

D. Acosta, P. Avery, V. Barashko, P. Bartalini, D. Bourilkov, R. Cavanaugh, A. Drozdetskiy, R.D. Field, Y. Fu, L. Gray, D. Holmes, T. Jones, B.J. Kim, S. Klimenko, J. Konigsberg, A. Korytov, K. Kotov, P. Levchenko, A. Madorsky, K. Matchev, G. Mitselmakher, Y. Pakhotin, C. Prescott, P. Ramond, J.L. Rodriguez, M. Schmitt, B. Scurlock, H. Stoeck, J. Yelton

**Florida International University, Miami, Florida, USA**

R.L. Alvarez, W. Boeglin, V. Gaultney, L. Kramer, L.M. Lebolo, S. Linn, P. Markowitz, G. Martinez, B. Raue, J. Reinhold

**Florida State University, Tallahassee, Florida, USA**

T. Adams, A. Askew, O. Atramentov, M. Bertoldi, E.F. Carrera Jarrin, W.G.D. Dharmaratna, Y. Gershtein, S.V. Gleyzer, S. Hagopian, V. Hagopian, M. Jenkins, K.F. Johnson, H. Prosper, H. Wahl

**Florida Institute of Technology, Melbourne, Florida, USA**

M. Baarmand, L. Baksay<sup>\*\*39</sup>, S. Guragain, M. Hohlmann, H. Mermerkaya, R. Ralich, I. Vodopyanov

**University of Illinois at Chicago (UIC), Chicago, Illinois, USA**

M.R. Adams, L. Apanasevich, R.R. Betts, E.J. Garcia-Solis, C.E. Gerber, D.J. Hofman, R. Hollis, A. Iordanova, S. Khalatian, C. Mironov, E. Shabalina, C. Smith, A. Smoron, T.B. Ten, N. Varelas

**The University of Iowa, Iowa City, Iowa, USA**

U. Akgun, E.A. Albayrak, A.S. Ayan, R. Briggs, W. Clarida, A. Cooper, P. Debbins, F. Duru, M. Fountain, N. George, F.D. Ingram, E. McCliment, J.P. Merlo, A. Mestvirishvili, M.J. Miller, A. Moeller, C.R. Newsom, E. Norbeck, J. Olson, Y. Onel, L. Perera, I. Schmidt, S. Wang, T. Yetkin

**Iowa State University, Ames, Iowa, USA**

E.W. Anderson, J.M. Hauptman, J. Lamsa

**Johns Hopkins University, Baltimore, Maryland, USA**

B.A. Barnett, B. Blumenfeld, C.Y. Chien, A. Gritsan, D.W. Kim, P. Maksimovic, S. Spangler, M. Swartz, N. Tran

**The University of Kansas, Lawrence, Kansas, USA**

P. Baringer, A. Bean, J. Chen, O. Grachov, T. Moulik, M. Murray, J.S. Wood, V. Zhukova

**Kansas State University, Manhattan, Kansas, USA**

D. Bandurin, T. Bolton, K. Kaadze, A. Khanov<sup>\*\*28</sup>, Y. Maravin, D. Onoprienko, R. Sidwell, N. Stanton, E. Von Toerne, Z. Wan

**Lawrence Livermore National Laboratory, Livermore, California, USA**

C.H. Cheng, J. Gronberg, D. Lange, D. Wright

**University of Maryland, College Park, Maryland, USA**

D. Baden, R. Bard, S.C. Eno, T. Grassi, N.J. Hadley, R.G. Kellogg, M. Kirn, S. Kunori, E. Lockner, F. Ratnikov, M.P. Sanders, A. Skuja, T. Toole

**Massachusetts Institute of Technology, Cambridge, Massachusetts, USA**

B. Alver, M. Ballintijn, G. Bauer, W. Busza, K.A. Hahn, P. Harris, M. Klute, I. Kravchenko, W. Li, C. Loizides, T. Ma, S. Nahn, C. Paus, S. Pavlon, J. Piedra Gomez, C. Reed, C. Roland, G. Roland, M. Rudolph, G. Stephans, K. Sumorok, S. Vaurynovich, G. Veres, E.A. Wenger, B. Wyslouch

**University of Minnesota, Minneapolis, Minnesota, USA**

D. Bailleux, S. Cooper, P. Cushman, A. De Benedetti, A. Dolgoplov, P.R. Duderov, R. Egeland, G. Franzoni, W.J. Gilbert, D. Gong, J. Grahl, J. Haupt, K. Klapoetke, Y. Kubota, J. Mans, R. Rusack, S. Sengupta, A. Singovsky, J. Zhang

**University of Mississippi, University, Mississippi, USA**

L.M. Cremaldi, R. Godang, R. Kroeger, J. Reidy, D.A. Sanders, D. Summers

**University of Nebraska-Lincoln, Lincoln, Nebraska, USA**

K. Bloom, B. Bockelman, D.R. Claes, A. Dominguez, M. Eads, D. Johnston, J. Keller, T. Kelly, C. Lundstedt, S. Malik, G.R. Snow, A. Sobol, D. Swanson

**State University of New York at Buffalo, Buffalo, New York, USA**

U. Baur, K.M. Ecklund, S. Gallo, M.L. Green, I. Iashvili, A. Kharchilava, A. Kumar, M. Strang

**Northeastern University, Boston, Massachusetts, USA**

G. Alverson, E. Barberis, O. Boeriu, R. Dunn<sup>\*\*40</sup>, G. Eulisse, T. McCauley, Y. Musienko<sup>\*\*41</sup>, S. Muzaffar, I. Osborne, S. Reucroft, J. Swain, L. Taylor, L. Tuura, D. Wood

**Northwestern University, Evanston, Illinois, USA**

B. Gobbi, M. Kubantsev, A. Kubik, M. Schmitt, E. Spencer, S. Stoynev, M. Szleper, M. Velasco, S. Won

**University of Notre Dame, Notre Dame, Indiana, USA**

B. Baumbaugh, N.M. Cason, A. Goussiou, M. Hildreth, C. Jessop, D.J. Karmgard, T. Kolberg, N. Marinelli, R. Ruchti, J. Warchol, M. Wayne

**The Ohio State University, Columbus, Ohio, USA**

B. Bylsma, L.S. Durkin, J. Gilmore, J. Gu, R. Hughes, P. Killewald, K. Knobbe, T.Y. Ling, G. Williams, B.L. Winer

**Princeton University, Princeton, New Jersey, USA**

F. Diales da Rocha, P. Elmer, D. Gerbaudo, V. Halyo, D. Marlow, P. Piroué, D. Stickland, C. Tully, T. Wildish, S. Wynhoff, Z. Xie

**University of Puerto Rico, Mayaguez, Puerto Rico, USA**

C. Florez, X.T. Huang, A. Lopez, S. Mehrabyan, H. Mendez, J.E. Ramirez Vargas, P. Ttito

**Purdue University, West Lafayette, Indiana, USA**

A. Apresyan, K. Arndt, K. Banicz, V.E. Barnes, G. Bolla, D. Bortoletto, D. Braun, A. Bujak, A. Everett, A.F. Garfinkel, L. Gutay, N. Ippolito, Y. Kozhevnikov<sup>\*\*1</sup>, A.T. Laasanen, C. Liu, V. Maroussov, P. Merkel, D.H. Miller, N. Neumeister, A. Sedov, I. Shipsey, H. Xu

**Purdue University Calumet, Hammond, Indiana, USA**

V. Cuplov, N. Parashar

**Rice University, Houston, Texas, USA**

P. Bargassa, G. Eppley, S.J. Lee, J. Liu, D. Maronde, M. Matveev, T. Nussbaum, B.P. Padley, J. Roberts, A. Tumanov, P. Yepes

**University of Rochester, Rochester, New York, USA**

A. Bodek, H. Budd, J. Cammin, Y.S. Chung, P. De Barbaro<sup>\*\*1</sup>, R. Demina, G. Ginther, Y. Gotra, U. Husemann, S. Korjenevski, D.C. Miner, W. Sakumoto, P. Slattery, P. Tipton, M. Zielinski

**The Rockefeller University, New York, New York, USA**

A. Bhatti, M. Convery, L. Demortier, K. Goulianos, K. Hatakeyama, C. Mesporian, K. Terashi

**Rutgers, the State University of New Jersey, Piscataway, New Jersey, USA**

E. Bartz, J. Doroshenko, E. Halkiadakis, P.F. Jacques, M.S. Kalelkar, D. Khits, A. Lath, A. Macpherson<sup>\*\*1</sup>, R. Plano, K. Rose, S. Schnetzer, S. Somalwar, R. Stone, G. Thomson, T.L. Watts

**University of Tennessee, Knoxville, Tennessee, USA**

G. Cerizza, G. Ragghianti, A. York

**Texas A&M University, College Station, Texas, USA**

A. Aurisano, A. Golyash, T. Kamon, C.N. Nguyen, J. Pivarski, A. Safonov, D. Toback, M. Weinberger

**Texas Tech University, Lubbock, Texas, USA**

N. Akchurin, L. Berntzon, K.W. Carrell, K. Gumus, C. Jeong, H. Kim, S.W. Lee, B.G. Mc Gonagill, Y. Roh, A. Sill, M. Spezziga, I. Volobouev, E. Washington, R. Wigmans

**Vanderbilt University, Nashville, Tennessee, USA**

T. Bapty, D. Engh, W. Johns, T. Keskinpala, E. Luiggi Lopez, S. Neema, S. Nordstrom, S. Pathak, P. Sheldon, E.W. Vaandering, M. Webster

**University of Virginia, Charlottesville, Virginia, USA**

D. Andelin, M.W. Arenton, M. Balazs, M. Buehler, S. Conetti, B. Cox, R. Hirosky, M. Humphrey, R. Imlay, A. Ledovskoy, D. Phillips II, H. Powell, M. Ronquest, D. Smith, R. Yohay

**University of Wisconsin, Madison, Wisconsin, USA**

M. Anderson, Y.W. Baek, J.N. Bellinger, D. Bradley, P. Cannarsa<sup>\*\*1</sup>, D. Carlsmith, I. Crotty<sup>\*\*1</sup>, S. Dasu, F. Feyzi, T. Gorski, K.S. Grogg, M. Grothe<sup>\*\*42</sup>, W. Hogg, M. Jaworski, P. Klabbers, J. Klukas, A. Lanaro, C. Lazaridis, J. Leonard, R. Loveless, M. Magrans de Abril, A. Mohapatra, G. Ott, D. Reeder, W.H. Smith, M. Weinberg, D. Wenman

---

<sup>\*\*1</sup>: Also at CERN, European Organization for Nuclear Research, Geneva, Switzerland

<sup>\*\*2</sup>: Also at University of Zagreb, Zagreb, Croatia

<sup>\*\*3</sup>: Also at California Institute of Technology, Pasadena, USA

- \*\*4: Also at Université de Haute-Alsace, Mulhouse, France
- \*\*5: Also at Université Louis Pasteur, Strasbourg, France
- \*\*6: Also at Izmir Institute of Technology (IYTE), Izmir, Turkey
- \*\*7: Also at Moscow State University, Moscow, Russia
- \*\*8: Also at Institute of Nuclear Research ATOMKI, Debrecen, Hungary
- \*\*9: Also at University of California, San Diego, La Jolla, USA
- \*\*10: Also at Tata Institute of Fundamental Research - HECR, Mumbai, India
- \*\*11: Also at University of Visva-Bharati, Santiniketan, India
- \*\*12: Also at University of California, Riverside, Riverside, USA
- \*\*13: Also at Centro Studi Enrico Fermi, Roma, Italy
- \*\*14: Also at ENEA - Casaccia Research Center, S. Maria di Galeria, Italy
- \*\*15: Also at Institute of Physics, Swietokrzyska Academy, Kielce, Poland
- \*\*16: Also at Warsaw University of Technology, Institute of Electronic Systems, Warsaw, Poland
- \*\*17: Also at University of Minnesota, Minneapolis, USA
- \*\*18: Also at Institute for Particle Physics, ETH Zurich, Zurich, Switzerland
- \*\*19: Also at Faculty of Physics of University of Belgrade, Belgrade, Serbia
- \*\*20: Also at Institut für Experimentelle Kernphysik, Karlsruhe, Germany
- \*\*21: Also at National Centre for Physics, Quaid-I-Azam University, Islamabad, Pakistan
- \*\*22: Also at Laboratoire Leprince-Ringuet, Ecole Polytechnique, IN2P3-CNRS, Palaiseau, France
- \*\*23: Also at University of Athens, Athens, Greece
- \*\*24: Also at University of Gent, Gent, Belgium
- \*\*25: Also at Imperial College, University of London, London, United Kingdom
- \*\*26: Also at Paul Scherrer Institut, Villigen, Switzerland
- \*\*27: Also at State Research Center of Russian Federation - Institute for High Energy Physics, Protvino, Russia
- \*\*28: Also at Institute for Theoretical and Experimental Physics, Moscow, Russia
- \*\*29: Also at Nigde University, Nigde, Turkey
- \*\*30: Also at Mersin University, Mersin, Turkey
- \*\*31: Also at Mugla University, Mugla, Turkey
- \*\*32: Also at Marmara University, Istanbul, Turkey
- \*\*33: Also at Kafkas University, Kars, Turkey
- \*\*34: Also at Suleyman Demirel University, Isparta, Turkey
- \*\*35: Also at Ege University, Izmir, Turkey
- \*\*36: Also at Rutherford Appleton Laboratory, Didcot, United Kingdom
- \*\*37: Also at KFKI Research Institute for Particle and Nuclear Physics, Budapest, Hungary
- \*\*38: Also at National University of Sciences And Technology, Rawalpindi Cantt, Pakistan
- \*\*39: Also at University of Debrecen, Debrecen, Hungary
- \*\*40: Also at Fermi National Accelerator Laboratory, Batavia, USA
- \*\*41: Also at Institute for Nuclear Research, Moscow, Russia
- \*\*42: Also at Università di Torino e Sezione dell' INFN, Torino, Italy



# Executive Summary

The Large Hadron Collider at CERN is due to begin operation at the end of 2007 opening a new energy frontier in particle physics. The LHC is ultimately expected to operate at  $\mathcal{L} = 10^{34} \text{ cm}^{-2} \text{ s}^{-1}$  and the CMS detector has been designed to cope with the high radiation and event rates expected at this luminosity. However, after several years of running at this luminosity, there will be strong motivation to increase the performance of the machine in order to expand the physics potential of the LHC. In addition, key elements of the detector and machine will not survive more than a few years at full LHC intensity.

An upgrade of the machine to  $\mathcal{L} = 10^{35} \text{ cm}^{-2} \text{ s}^{-1}$  the SLHC, is currently under study. The potential of a factor 10 increase in luminosity offers an opportunity to explore new physics, but will make severe demands on the CMS detector. It is likely that the tracking system will need to be replaced to cope with both the higher occupancy and radiation resulting from high luminosity running. In addition, the trigger system will have to be replaced, and the Level-1 may have to incorporate elements of the tracking information.

Design of detectors for CMS began in 1992, and it is clear from the experience of building the elements of CMS, that a minimum of 6 years would be required from first R&D on a new detector until deployment in CMS. Hence it is timely now at the start of LHC operation to begin development on the detectors required for the SLHC upgrade.

This Expression of Interest briefly describes the motivation and scope of the likely CMS upgrades for the SLHC. It is intended to outline the required avenues of R&D which must proceed in the next years in order to prepare for the SLHC, and will be followed by a more detailed Letter of Intent.

## Structure of the Expression of Interest

Chapter 1, the Introduction, discusses the motivations for the upgrade.

Chapter 2 describes potential upgrades to the tracking system, and key areas of R&D which are required.

Chapter 3 motivates the replacement of the trigger system and gives indications on possible upgrades.

Chapters 4 and 5 detail the work which may be required to operate the calorimeter and muon systems at the SLHC.

Chapter 6 outlines the organization of the upgrade work, and gives indicative cost estimates and timescales for the upgrades.



# Contents

<b>1</b>	<b>Introduction</b>	<b>3</b>
1.1	The SLHC . . . . .	3
1.2	The CMS detector . . . . .	4
1.3	Physics Case . . . . .	6
1.3.1	Standard Model . . . . .	6
1.3.2	Beyond the Standard Model . . . . .	7
<b>2</b>	<b>Tracker Upgrades for SLHC</b>	<b>11</b>
2.1	Introduction . . . . .	11
2.2	Conclusions from CMS SLHC workshops . . . . .	11
2.3	Pixels and Strips for the SLHC . . . . .	13
2.4	Sensor issues . . . . .	15
2.5	Electronic issues . . . . .	16
2.6	Power . . . . .	17
2.7	System issues . . . . .	18
2.8	Triggering using the tracker . . . . .	18
2.9	Roadmap for a tracker upgrade . . . . .	19
<b>3</b>	<b>SLHC Trigger and Data Acquisition</b>	<b>21</b>
3.1	Introduction . . . . .	21
3.1.1	TriDAS Goals . . . . .	21
3.1.2	TriDAS Performance . . . . .	21
3.1.3	TriDAS SLHC Strategy . . . . .	22
3.2	SLHC Trigger Operation . . . . .	22
3.2.1	Crossing Frequency . . . . .	22
3.2.2	Trigger Thresholds . . . . .	22
3.2.3	Trigger Rates . . . . .	23
3.3	SLHC Trigger Primitives . . . . .	23
3.3.1	Calorimeter and Muon Triggers . . . . .	23
3.3.2	Tracking Triggers . . . . .	24
3.4	SLHC Trigger Algorithms . . . . .	25
3.4.1	Tracking Trigger Algorithms . . . . .	25
3.4.2	CalorimeterTrigger Algorithms . . . . .	25
3.5	SLHC Trigger Architecture . . . . .	26
3.6	SLHC Trigger Latency . . . . .	26

3.7	SLHC DAQ . . . . .	27
3.8	SLHC Trigger and DAQ R&D . . . . .	27
3.8.1	TTC Upgrade . . . . .	28
3.8.2	Trigger Upgrade . . . . .	28
3.8.3	DAQ Upgrade . . . . .	28
<b>4</b>	<b>Upgrades to the Calorimeters</b>	<b>29</b>
4.1	ECAL issues for SLHC . . . . .	29
4.1.1	ECAL detectors . . . . .	29
4.1.2	ECAL electronics . . . . .	29
4.2	HCAL issues and R&D for the SLHC . . . . .	30
4.2.1	Radiation resistant replacement for high eta HE scintillator . . . . .	30
4.2.2	New photodetectors . . . . .	30
4.2.3	New electronics . . . . .	31
<b>5</b>	<b>Upgrades to the Muon Systems</b>	<b>33</b>
5.1	R&D topics for the SLHC . . . . .	33
<b>6</b>	<b>Project Office</b>	<b>35</b>
6.1	Changes to the Infrastructure . . . . .	35
6.2	Organization of Upgrade work . . . . .	35
6.3	Cost Estimates and timescales . . . . .	36
	<b>References</b>	<b>37</b>



## Chapter 1

# Introduction

The Large Hadron Collider (LHC) [1], at the CERN Laboratory, the European Laboratory for Particle Physics, outside Geneva, Switzerland, will be completed in 2007. The LHC will collide two proton beams, circulating in opposite directions, at an energy of 7 TeV each (centre-of-mass energy  $\sqrt{s} = 14$  TeV). The accelerator has been designed to run at a peak luminosity of  $\mathcal{L} = 10^{34} \text{ cm}^{-2} \text{ s}^{-1}$ .

The CMS experiment [2, 3] is a general purpose detector designed to explore physics at the TeV energy scale [4–6]. It is expected that the data produced at the LHC will reveal the electroweak symmetry breaking mechanism (EWSB) and provide evidence of physics beyond the standard model.

The detector and the accelerator were designed for a physics program which would deliver several hundred  $\text{fb}^{-1}$  of integrated luminosity at a peak luminosity of  $\mathcal{L} = 10^{34} \text{ cm}^{-2} \text{ s}^{-1}$ . Continued running of the LHC much beyond  $500 \text{ fb}^{-1}$  without upgrades of the machine and detectors will not be profitable due to;

- elements of the machine reaching their radiation damage lifetime,
- radiation damage to the central tracker,
- the very long time required to further accumulate a sufficiently large data sample to significantly increase the desired statistical precision.

An upgrade of the LHC, the *Super* LHC (SLHC), would aim to increase the peak luminosity by an order of magnitude, and to deliver  $\approx 3000 \text{ fb}^{-1}$  during its operation. The SLHC would require substantial changes to the machine near the interaction region of CMS, and also likely changes to the bunch structure of the machine. CMS would require replacement of the central tracker to cope with the higher occupancy and radiation as well as the trigger and data acquisition systems in order to cope with an increased data volume. It is expected that the calorimeter and muon systems will require only minor modifications, except possibly the very forward calorimeters.

### 1.1 The SLHC

The LHC machine was designed for a peak luminosity of  $\mathcal{L} = 10^{34} \text{ cm}^{-2} \text{ s}^{-1}$ . It is likely that it will take several years of operation of the LHC before this level can be achieved.

By increasing the the number of protons in each bunch from  $1.15 \times 10^{11}$  to  $1.7 \times 10^{11}$ , and upgrading the LHC RF system it may be possible to reach  $\mathcal{L} = 2 \times 10^{34} \text{ cm}^{-2} \text{ s}^{-1}$  after 4–5 years of running. This would be the *ultimate* luminosity [7] achievable with the current

Machine elements. Figure 1.1 shows a potential scenario for the delivered luminosity of the LHC machine for the case of design luminosity being achieved after 3 years of operation, and a second case of exceeding design luminosity by a factor of 2 after 5 years operation. In both cases the lifetimes of the tracking detectors are exceeded after around 7 years. The quadrupole triplets near the interaction region have a lifetime of around  $700 \text{ fb}^{-1}$ , which would likely be reached in about 10 years of operation. Also shown are the number of years required to halve statistical errors as a function of years of operation. It rapidly takes a very long time to substantially reduce statistical errors when the peak luminosity remains constant.

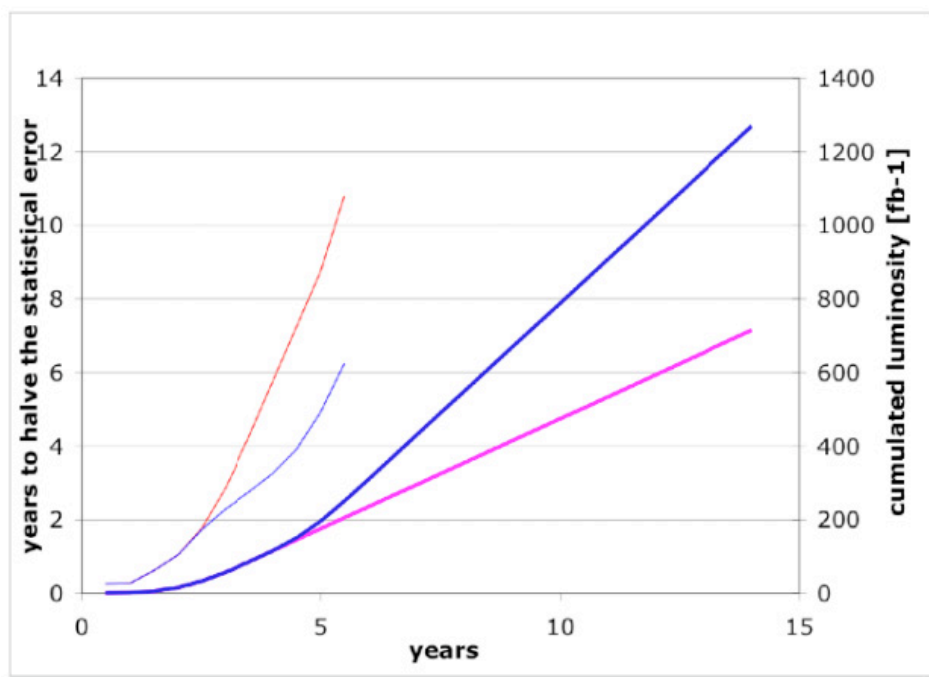

Figure 1.1: The thick lines on the right show integrated delivered luminosity (right hand scale) for two potential LHC running scenarios as a function of years from startup. The thin lines on the left (left hand scale) show the run-time required to halve statistical errors. [7].

In order to reach a factor of 10 increase in peak luminosity,  $\mathcal{L} = 10^{35} \text{ cm}^{-2} \text{ s}^{-1}$ , it is proposed [7–9] to replace the machine elements around the interaction region as well as changing the bunch structure. Two proposals are currently being considered. In the first, the number of bunches are doubled, and the bunch crossings arrive at 80 MHz (12.5 ns between crossings) instead of the 40 MHz at the LHC. In this scenario, the number of minimum bias pile-up events in each crossing increases over the LHC nominal by a factor of  $\approx 5$ . Unfortunately this configuration increases the susceptibility to electron cloud effects in the machine, and it may be difficult to achieve full peak luminosity. The second proposal would have slightly longer bunches with a greater number of protons arriving each 50 ns. This would ease the electron cloud effects, but would increase the number of pile-up events in each crossing to more than 300.

## 1.2 The CMS detector

The CMS detector measures roughly 22 meters in length, 15 meters in diameter, and 12,500 metric tons in weight. Its central feature is a 4 Tesla solenoid, 13 meters in length, and 6

meters in diameter. Along with the central silicon microstrip tracking detector, the electromagnetic and hadronic calorimeters are contained within the solenoid coil. Muon detection is embedded in the flux return iron of the magnet. A drawing of the detector can be seen in Figure 1.2, and a detailed description of the construction and performance of its detector systems can be found in [10].

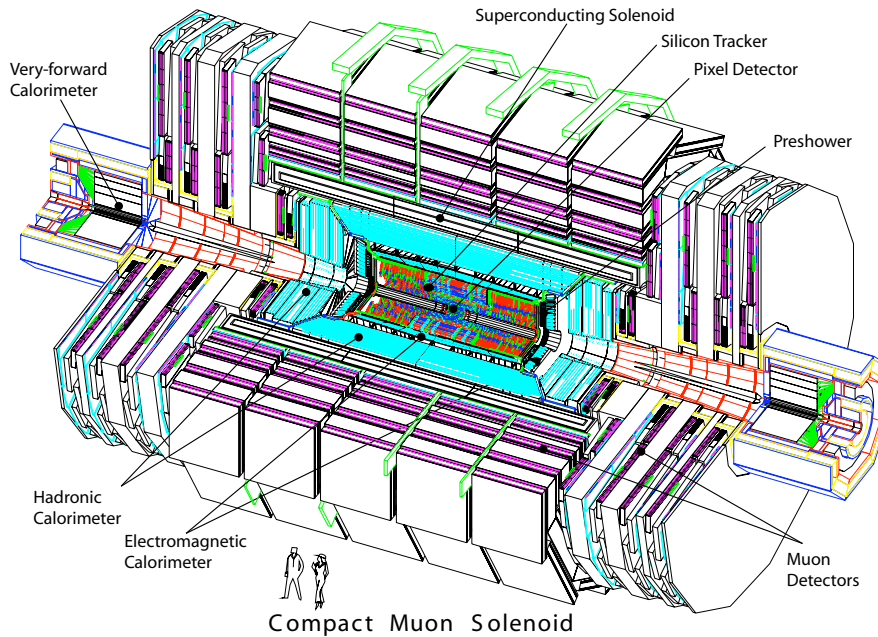

Figure 1.2: The CMS detector

The innermost tracking for the barrel region (BPIX) is accomplished with a three layer (4.4 cm, 7.3 cm, 10.2 cm) silicon micro pixel detector and with two disks of pixels (FPix) in each forward region (34.5 cm and 46.5 cm from the IP) with a total area of approximately  $1 \text{ m}^2$  composed of 66 million  $100 \times 150 \mu\text{m}^2$  area pixels. These detectors are designed to withstand the high occupancy and fluence of the LHC. The remaining tracking layers are composed of 11 million channels of silicon microstrip detectors. In total nearly  $200 \text{ m}^2$  of detectors organized in an inner barrel (TIB) 4 layers occupying a radius 20 cm – 50 cm, an outer barrel (TOB) 6 layers occupying a radius 55 cm – 120 cm, and two endcap detectors (TEC, TID). At nominal luminosity, the expected occupancy of the strips in the TIB at LHC is 2–3% while the occupancy in the TOB should be  $\approx 1\%$ . As described above, the SLHC machine upgrade scenarios could increase these expected occupancies by up to a factor of 20. A combination of increasing the area of the pixel detector, and shortening the strip length will be required to cope with the increased occupancy. In addition new technologies may be required for the innermost layer where the radiation effects will be extreme.

The electromagnetic calorimeter has a barrel section covering the region  $|\eta| < 1.479$  and two endcaps completing the coverage up to  $|\eta| < 3.0$ . The barrel consists of 61200 lead tungstate crystals read out by silicon avalanche photodiodes (APDs). The two endcaps contain a total of 14648 crystals read out by vacuum phototriodes (VPTs). Hadronic calorimetry is achieved with scintillator embedded in brass absorber, where the light is read out using hybrid photodiodes (HPDs). The barrel sections of these calorimeters are expected to operate even in the extreme environment of the LHC, although the forward regions may require replacement or modification. The fate of the very forward Hadronic calorimeter  $3 < |\eta| < 5$  may de-



pend on modifications required in the CMS interaction region in order to achieve the SLHC luminosity, and the importance for physics of the very forward region at high luminosity.

The CMS muon detection system uses three technologies. Drift tubes (DT) are used in the CMS barrel, Cathode Strip Chambers (CSC) are used in the endcaps, and Resistive Plate Chambers (RPC) are used in parallel with the other detectors in both the barrel and endcap. The muon system is well shielded by the CMS iron yoke, and it is expected that the detectors should continue to operate in the SLHC regime, with only a potential need for changes in the shielding in the forward regions ( $2 < |\eta| < 4$ ) and possible upgrades for the on-detector electronics required.

The CMS trigger takes input from the calorimeters and muon systems to form a Level-1 decision. At each Level-1 trigger, the data is sent to a higher level software trigger (Level-3) processing farm where the full event data is available for making a trigger decision. The current maximum rate for Level-1 triggers is 100 kHz. It is proposed that any upgrade continue to respect that limit, but this implies a required increase in the bandwidth of the data acquisition system. In addition it appears that the current muon and calorimeter triggers may not have sufficient capability to reject background at high luminosity. In order to greatly increase the rejection power of the Level-1 trigger, it is proposed to bring in information from the upgraded tracking detector. This requires substantial new developments in the tracking system, and a complete replacement of the central trigger, but offers the possibility of much more information in the trigger decision taken at the SLHC

## 1.3 Physics Case

The SLHC, with its order of magnitude greater luminosity, will extend the discovery reach of the LHC for new particles such as those arising from Supersymmetry, or new forces and will allow for detailed measurements of Standard Model processes and any new phenomena discovered during LHC operations. While it is difficult to predict what physics will be most important to study after the LHC era, some specific possibilities are listed here that can benefit from the increased luminosity of the SLHC. Not addressed here, but equally important, are upgrades to the detectors and electronics that can improve upon the physics measurements even without increased luminosity (such as by lowering  $E_T$  thresholds, adding additional detectors, bringing in tracking into the Level-1 trigger, or by reducing experimental systematic uncertainties in some manner).

### 1.3.1 Standard Model

The precision measurement of electroweak parameters is a tool to look indirectly for physics beyond the Standard Model. One such measurement is that of multiple gauge boson production. The luminosity of the SLHC will provide for improvements on the limits of anomalous triple and quartic gauge boson couplings by a factor of about two, depending on the coupling. For this measurement, only the leptonic decay channels of the bosons are used, thus a good lepton identification and acceptance similar to the one for the LHC environment must be guaranteed. The sensitivity of the measurements will reach that of the radiative corrections in the Standard model ( $\sim 0.001$ ) for  $\lambda$  type couplings, and should therefore allow for a meaningful test of these corrections and others that arise for example in SUSY models. Even measurements of events with four gauge bosons in the final state will become accessible at the SLHC.

The Standard Model Higgs, if it exists, will have been discovered by the time the SLHC starts its operation. It will however remain important to measure its properties more precisely. For example the SLHC offers the opportunity to improve the measurement of the ratios of couplings with up to a factor two if both the  $H \rightarrow \gamma\gamma$  and  $H \rightarrow WW$  decay modes can be detected with similar accuracy as for the data collected at the LHC. This will allow the measurement of the ratios of couplings to better than 10%. Rare Higgs decays can be observed, i.e. the important channel  $H \rightarrow \mu\mu$  becomes accessible, and the Yukawa coupling can be determined to better than 20%. The most important and probably most challenging measurement will be the one that can map out the shape of the Higgs potential, and thus provide the ultimate proof of the Higgs mechanism as the one responsible for electroweak symmetry breaking. The information on the potential is extracted from the Higgs self-coupling, measured in events which contain two Higgs bosons in the final state. The cross section for this process is small, of the order of a few tens of femtobarns. The decay channel that can be used is  $HH \rightarrow WWWW \rightarrow \nu l j j \nu l j j$ . Hence good jet reconstruction in the experimental environment of the SLHC will be mandatory. With the luminosity of the SLHC, the self-coupling can be measured with a precision of 25% if the Higgs has a mass between 160 and 180 GeV/c<sup>2</sup>, and will be sufficient to demonstrate that the minimum of the Higgs field is not at the origin. Finally, the discovery potential for heavy Higgses such as the  $H$ ,  $A$  bosons in SUSY models can be extended by roughly 100 GeV/c<sup>2</sup> in the  $\tan\beta - M_A$  plane.

If no Higgs is discovered then it is expected that the high energy scattering of electroweak gauge bosons will show structure beyond that expected in the Standard Model at  $WW$  and  $ZZ$  masses of order of 1 TeV. The discovery of such effects may be very difficult at the LHC. A factor of 10 increase in luminosity may be required in a number of scenarios, to discover e.g.  $ZZ$  scalar or vector resonance production. Again isolated high  $p_T$  leptons need to be measured with similar efficiency and quality as during the LHC running. The  $WW$ ,  $ZZ$  scattering analyses require also jets to be tagged in the region of  $2 < |\eta| < 5$ , i.e. the so called forward jet tagging.

Most of the top quark studies at the LHC will have been done before SLHC comes into operation. An important exception is the search for rare top decays. In order to gain sensitivity with respect to the results obtainable at the LHC, it is however imperative that the ability to tag b-quarks with a secondary vertex technique is conserved at the SLHC. If so, a sensitivity to the decays  $t \rightarrow qZ$  and  $t \rightarrow q\gamma$  of order  $10^{-6}$  is achievable, which is of interest for several theories of New Physics.

## 1.3.2 Beyond the Standard Model

### 1.3.2.1 Supersymmetry

If Supersymmetry (SUSY) has not yet been discovered in data samples collected during LHC running, inclusive searches may continue with the larger integrated luminosity of the SLHC. For example, in the minimal Supergravity model (mSUGRA), a search for an excess of events in the high- $E_T$  jets and large  $E_T^{\text{miss}}$  signature can extend the discovery reach by an additional 0.5 TeV in squark and gluino mass (from 2.5 to 3.0 TeV/c<sup>2</sup>) in going from 100 fb<sup>-1</sup> to 1000 fb<sup>-1</sup> [11]. Such a search is based on measurements made by the calorimeters, where the jet energy deposition (and thus the jet  $E_T$  threshold) scales with the SUSY mass scale. For inclusive searches involving leptons, we note that the lepton  $p_T$  is less correlated with the SUSY mass scale since many leptons originate from the cascade decays of SUSY particles. Thus, for searches involving leptons, it is important to maintain similar trigger and offline  $p_T$  thresh-

olds as during LHC operation.

For some of the scenarios studied in [12], where the sparticle masses are around  $2 \text{ TeV}/c^2$ , the yield of sparticles at the LHC in usable decay channels is too low to detect anything more than a hint for a new particle. The SLHC will then make the discovery and allow for mass measurements. An example is the so called point K ( $m_0 = 1000 \text{ GeV}/c^2$  and  $m_{1/2} = 1200 \text{ GeV}/c^2$ ). The effective mass of the jets, leptons, and  $E_T^{\text{miss}}$  will show a clear excess of 500 events over a background of 100 events for SLHC luminosities. Also the exclusive decay channel into  $q\tilde{\chi}q\tilde{\chi}$  becomes observable at the SLHC with 120 signal events for 30 background events at an integrated luminosity of  $3000 \text{ fb}^{-1}$ . The decay  $\tilde{\chi}_2 \rightarrow \tilde{\chi}_1 h$  becomes detectable with the same luminosity.

If evidence for SUSY is discovered, it will be important to measure more exclusive final states in order to elucidate the sparticle mass spectrum. This can be done by measuring dilepton mass edges, for example, which is a striking signature of mSUGRA models and whose value depends on the masses of the first and second-lightest neutralinos. But information can also be extracted from the edges and thresholds of quark-lepton, quark-lepton-lepton, and quark-quark-lepton-lepton distributions as well, which depend on combinations of the neutralino, squark, and gluino masses [5, 13, 14]. The study reported in [13] indicates the feasibility in carrying out a deconvolution of the sparticle masses for the low mass mSUGRA benchmark point "SPS1a," and to extract masses with an accuracy of a few percent using LHC luminosities. However, for higher mass SUSY scenarios, the statistics available for such measurements will be much reduced and SLHC luminosities may be required to disentangle the sparticle masses.

While to merely extend the mass reach search for evidence for SUSY to masses of about 3 TeV high  $E_T$  jet measurements will be especially important, in order to disentangle the particle spectrum it will be important to maintain the present tracker capabilities and performances in terms of b and  $\tau$  tagging and lepton isolation, thus the need for improved granularity of the tracker.

Equally important, but difficult, is the attempt to determine the spin of the new particles to understand whether counterparts to the Standard Model particles are observed with opposite spin statistics, or whether some other new phenomenon is observed such as Universal Extra Dimensions, which can emulate the mass spectrum of SUSY. For example, as reported in [15], it is possible to determine the spin of the  $\tilde{\chi}_2^0$  in the decay  $\tilde{q}_L \rightarrow q_L \tilde{\chi}_2^0 \rightarrow q_L \ell \tilde{\ell}_R \rightarrow q_L \ell^+ \ell^- \tilde{\chi}_1^0$  by examining SUSY events containing two oppositely-charged same-flavour leptons and a high  $E_T$  quark, and comparing the difference in the invariant mass distribution of  $m(\ell^+ q)$  versus  $m(\ell^- q)$ . The dependence of the asymmetry of the distribution with the lepton-quark mass is sensitive to the spins involved in the decay, and since the LHC is a  $pp$  collider it produces more squarks than anti-squarks so the effect is not washed out. The sign of the asymmetry also indicates which slepton chiral state is involved in the process. A feasibility study in [15] shows that the reconstructed distribution is distinguishable from the case of no spin correlations for one studied mSUGRA point ( $m_0 = 100 \text{ GeV}$ ,  $m_{1/2} = 300 \text{ GeV}$ ,  $A_0 = 300$ ,  $\mu > 0$ ,  $\tan \beta = 2.1$ ) assuming at least  $150 \text{ fb}^{-1}$  of integrated luminosity. While more work will be needed to understand if this result is general enough to distinguish SUSY from UED in more than one instance, it is promising and clearly will require SLHC-sized data samples.

### 1.3.2.2 New Gauge Bosons

Many grand unified theories, extra dimension theories and superstring inspired theories predict additional heavy neutral and charged gauge bosons ( $Z'$ ,  $W'$ ). Such bosons lead to striking resonances in the dilepton final state above the Drell-Yan spectrum. The SLHC reach can be extrapolated from that expected for the LHC since the sensitivity to pile-up is expected to be small. While the amount of integrated luminosity required for a  $5\sigma$  discovery at a given  $Z'$  mass depends on the particular model (see for example Figs. 3.20 and 14.23 in [16]), in general one can expect to be able to extend the reach in  $Z'$  mass by about  $1.2 \text{ TeV}/c^2$  in going from a  $100 \text{ fb}^{-1}$  sample to a  $1000 \text{ fb}^{-1}$  sample for both dielectron and dimuon final states (extrapolating from the studies reported in [16]). This implies a sensitivity to neutral gauge bosons with masses up to  $5\text{--}6 \text{ TeV}/c^2$  depending on the considered models. For an asymptotic limit of  $3000 \text{ fb}^{-1}$ , one should expect a discovery reach of  $6.5 \text{ TeV}/c^2$  for some  $Z'$  models. The reach is similar for  $W'$  bosons. [11].

### 1.3.2.3 Dilepton Resonance Spin Discrimination

If a resonance is observed in the dilepton final state, the next step would be distinguish between the possible  $Z'$  models and to differentiate between a spin-1  $Z'$  resonance and a spin-2 graviton, appearing in various extra dimension models, through measurements of the forward-backward asymmetry and the angular distribution of the decay. The forward direction in a symmetric  $pp$  collider is taken to be the direction of motion of dilepton system, which becomes a better approximation of the true incident quark direction the higher the rapidity for the decay products. Thus, it is important to maintain good coverage in the forward region up to rapidities of  $|\eta| > 2$ , for identifying the leptons used in the angular measurements analysis.

The ability to distinguish between several  $Z'$  models via measurements of the forward-backward asymmetry is addressed in [16, 17]. The conclusion of the statistical analysis in [17] is that with an integrated luminosity of  $400 \text{ fb}^{-1}$ , one can distinguish between either a  $Z_\chi$  or  $Z_{\text{ALRM}}$  and one of four other  $Z'$  models ( $Z_{\text{SSM}}$ ,  $Z_\psi$ ,  $Z_\eta$ , and  $Z_{\text{LRM}}$ ) with a significance level of more than  $3\sigma$  up to a  $Z'$  mass of between  $2.0$  and  $2.7 \text{ TeV}/c^2$ . One can distinguish among the four other  $Z'$  models with the same level of significance only up to a mass of  $1\text{--}1.5 \text{ TeV}/c^2$ , whereas  $Z_{\text{ALRM}}$  and  $Z_\chi$  are indistinguishable for masses larger than  $1 \text{ TeV}/c^2$ . Clearly if a  $Z'$  resonance is discovered at a higher mass than these ranges, or if one is unlucky in the  $Z'$  couplings, the significantly larger integrated luminosities achievable at the SLHC will be required.

The discrimination between spin-1 and spin-2 resonances at the LHC is discussed in [18], and a feasibility study using the CMS detector is presented in [16]. In order to distinguish between a RS graviton from a  $Z'$  at the  $2\sigma$  level at a mass of  $3.0 \text{ TeV}/c^2$  requires  $290 \text{ fb}^{-1}$  for a coupling of  $c = 0.1$ , increasing to  $1200 \text{ fb}^{-1}$  for a coupling of  $c = 0.05$ . Discrimination between spin-1 or spin-2 from spin-0 requires even more integrated luminosity, as does distinguishing the spin of higher mass resonances.

### 1.3.2.4 Compositeness and other BSM signals

The tenfold increase in luminosity at the SLHC will give access to jets with  $E_T \sim 4.5 \text{ TeV}$ . This offers the opportunity to extend the search for quark substructure. The sensitivity can be increased by a factor 1.5.

An increase in mass reach of about 30% when increasing the integrated luminosity from  $300 \text{ fb}^{-1}$  to  $3000 \text{ fb}^{-1}$ , is expected for heavy mass objects searches in the TeV range, as predicted various other theories.

## Chapter 2

# Tracker Upgrades for SLHC

## 2.1 Introduction

The main motivation for a luminosity upgrade is to provide more statistics to improve physics studies beyond those possible at the LHC. Detector performance should remain similar to that at the LHC in the presence of higher particle fluxes, detector occupancies, trigger rates, and radiation damage. The inner tracking detectors will need complete replacement, with new systems adapted to the even harsher SLHC environment.

Until the LHC has been operating for some years and discoveries have been made, the principal future physics areas will remain speculative. In the examples of SLHC physics discussed in Chapter 1.3, electron and muon track reconstruction will remain as important but there will be greater numbers of energetic jets with more particles and higher track densities. Higher granularity of the tracking system will evidently be required, which poses important questions of channel count, power and material budget.

The magnitude of tracker R&D and construction will be guided by LHC discoveries since most require several years of operation and data analysis. Issues arising from LHC machine operation might be visible early and guide the design. However, the design of a new tracker, with outline plans for power, cooling and other services needs significant time. Therefore the strategy proposed by CMS is an intermediate step before final commitments are made to a replacement tracker, if possible to install a new pixel layer about 5 years after LHC start-up. This would provide a means of demonstrating new technical solutions at reasonable cost before embarking on the complete tracker replacement and allow some experience to be gained, or tuning of the detector design.

In addition to upgrades of the CMS trigger off-detector electronics, it has emerged that it is highly desirable to include tracker data for the first time in the level-1 trigger. The principal reason is that transverse momentum thresholds will no longer provide sufficient discrimination at the SLHC to control trigger rates. However, implementing a tracking trigger represents a major challenge.

## 2.2 Conclusions from CMS SLHC workshops

CMS has organised four SLHC workshops since 2004, the latest in April 2006 [19], to prepare for experiment upgrades. One conclusion which has not so far been challenged is that there is no obvious reason for major changes in specifications for momentum and spatial resolution, which determine detector parameters. Tracker sensor lengths should reduce to cope with in-

creased occupancy, although it should be noted that CMS can probably operate with higher occupancy values than at present. Studies of track reconstruction, using zero-suppressed data, in heavy-ion collisions [20] show very promising performance, with occupancies comparable to SLHC, but with lower LHC clock speed. Operating with increased occupancy would certainly help to reduce power requirements and channel count. However it should be noted that some aspects of heavy ion operation are very different from that with protons, in particular proton-proton collisions in LHC give rise to many collisions in the same beam crossing. At the SLHC, there will be an even higher number and this will add complexity to the track reconstruction and pattern recognition.

Although the centre-of-mass energy of the SLHC will be the same as that of the LHC, emphasis will shift to exploring rarer events with more energetic jets. Tracks in such jets tend to be very close to each other, thereby complicating pattern recognition. It remains to be studied what implications this has for increased tracker granularity.

Several issues have been highlighted in these discussions.

- Power will be a crucial issue, despite trends in lower power circuits and lower supply voltages in deep sub-micron CMOS. There are several reasons including channel count, amplifier noise issues, power dissipation by silicon sensors and power dissipation in cables.
- The material budget should not increase. Improvements in physics performance would arise from material reductions and likely to be more beneficial than over-specifying granularity which will cost power and material.
- The costs of present pixel systems are estimated to be 500 CHF/cm<sup>2</sup>, dominated by bump-bonding, but, even if significant reductions can be made, will remain considerably higher than current microstrip system costs (40 CHF/cm<sup>2</sup>).
- Despite the experience gained in the construction of the present tracker, it should be anticipated that large systems will remain challenging to build, and the time needed for both R&D and system qualification is usually underestimated. CMS was successful in pioneering automation of tracker module production but the large number of module variants adds considerably to logistics problems. If a reduction in the number of module types could be achieved, assembly and integration tasks would be simplified. Further increase in automation of assembly, possibly even including outsourcing, should be considered.
- Sensor radiation hardness is a concern, but principally for innermost layers, and the choice of pixel sensor material is an open question. However, the optimal choice of sensor material for outer layers may be different than at present.
- Off-detector electronics will benefit significantly from technology evolution, as well as computer processing power, which should be borne in mind when specifying the occupancy requirements. However, following some of the technology trends will remain challenging, given the special constraints imposed by tracker construction, especially for customised low-mass components and optical links.
- The trigger requirement is considered by many to be vital to the upgrade for SLHC. More selective, and potentially biased, trigger selection criteria will be required to contain the rate. The proposed SLHC latency of 6.4  $\mu$ s, i.e. 512 bunch crossings at 80MHz, will need deeper on-chip buffers than at present.

## 2.3 Pixels and Strips for the SLHC

The present CMS tracking is based on the massive use of silicon strip detectors for the outer tracking regions and on hybrid pixel technology to deal with high particle track rates in the vicinity of the interaction region. Although both systems use fine pitch segmented silicon as a basic sensor material there are a few fundamental differences that distinguish the two systems.

The silicon strip systems (TIB, TOB, TEC) are based on a non-zero suppressed analog readout. The strips with their long aspect ratio use fine pitch wire bonding to perform the connection between the sensor elements and the readout chips. In addition the strip system is characterized by the fact that the sensor surface is much larger than the silicon surface of the readout chips.

The pixel systems (BPIX, FPIX), however, are based on a completely different zero-suppressed readout scheme. In addition, a 2-dimensional connection technique (micro-bump-bonding) is used to bring the sensor signals to the readout chips and therefore requires a one to one coverage of the sensor surface with readout chips.

However, the crucial difference between pixels and strips may well be the way they achieve position resolution in both directions. In case of pixels this is done by keeping the sensor element (pixel) very small in both directions, whereas for the strips a stereo-technique is needed to get sufficient coordinate precision in the long direction of the strips.

In a future SLHC tracker the distinction between strips and pixels may well become much more blurred, since zero-suppression and bump bonding could in principle also be used in outer strip-like layers. The way position resolution is achieved in both directions, however, might become the crucial criterion to distinguish between pixels and strip-like sensors.

In the present CMS tracker the radial division between the strip system for medium and large radii ( $> 20$  cm) and the hybrid pixel system for small radii ( $< 12$  cm) is very much the result of a compromise between cluster merging and channel occupancy and exploding costs in the case of the pixel system. In addition it should be mentioned that the power density of the pixel system is about ten times higher than for the current strip system.

As the luminosity increases and we go from the LHC machine to the SLHC, the border between the two systems will clearly have to move outward. Although the present pixel technology is perfectly able to deal with the SLHC track rates and densities in the medium radius range it is also clear that costs of the current hybrid pixel technology need to be brought down substantially. Either this is done through a low cost technology or new, different pixel technologies (like MAPS, monolithic pixels, amplifying pixel structures etc.) have to be developed which avoid the use of the currently expensive micro-bump-bonding.

The conception and design of a new SLHC tracking system will certainly need a large number of careful studies to be done with some following key issues to be addressed:

- Channel density for the different layer radii. This is probably the most sensitive parameter defining the power dissipation of the system. A small pixel/strip size implies a small sensor capacity, which in turn gives a good signal to noise performance with a given preamplifier power. However, the increase of channels per unit area may still result in an overall higher power consumption. This is due to a minimal power level that is always required for every readout channel and which does not scale with the sensor capacity. This problem may even get worse due to



the fact that smaller pixels will create larger cluster sizes, which in turn will result in increased data traffic. This again costs more power and requires more data links (material budget) to the outside world.

- Powering schemes to reduce material budget. The present pixel system has on-chip regulators that allow smaller LV cable cross-sections within tracking volumes. Other possibilities to be studied would be serial powering schemes or DC-DC converters (charge pumps). Issues of failure tolerance, load variations and system stability need to be studied.
- Development of new low mass cooling techniques, that allow robust operation even in the case of individual modules (heat loads) being switched off.
- Implementation of triggering layers in the tracking system. Any triggering functionality will always cost extra power and extra material budget. It has to be carefully considered what would be the optimal radius for this material while getting the best triggering benefits.
- Development of high bandwidth readout schemes with lowest possible power dissipation.
- Reduce material budget overhead due to plugs and connectors within the sensitive tracking volume.
- How to ensure easy assembly, integration and repair capability. Special emphasis should go on minimizing interdependencies off the different subsystems in planning, assembly and integration.
- Development of low cost single sided silicon sensors that after heavy irradiations allow operation in a partial depletion mode (n+ on p-sensors).
- Cost scaling for other different non-hybrid pixel technologies

This list is certainly not complete and many other issues will have to be studied as well. The decision on how many subsystems and how many different technologies are needed is far from trivial. It seems clear, however, a tracker for the SLHC should not only be able to deal with a *20 times higher occupancy* (factor ten from luminosity and a factor two from the recent LHC machine group recommendation to use a 50 ns bunch crossing scheme) and at the same time *improve on the material budget problem* which is already the biggest concern with the current silicon tracker.

The RD to resolve these issues must be accomplished relatively soon. The innermost pixel barrel layer, and perhaps the endcaps, will suffer radiation damage and will probably need to be replaced after about 4 years of LHC operation. This will occur a few years before the major shutdown for the SLHC upgrade. Fortunately, the pixel detector is mounted on rails so that it can easily be removed and reinserted into the detector during shutdowns. This feature makes it relatively easy to upgrade the detector. This region also has some unused space and some unused cable runs. Taken together, these properties provide the opportunity to try out parts of the SLHC technologies and detectors in the context of doing physics in the latter part of the first phase of LHC operations. An intermediate partial tracker replacement that is aimed at implementing some of the features needed for the SLHC, including new tracking layers designed for use in the Level 1 trigger, is often referred to as the “pathfinder” system.

On October 9–12, 2006, the CMS Pixel Group, together with members of the silicon strip tracker group and the trigger group, held a workshop to discuss these issues. Key recommendations for R&D were:

1. to adopt or develop a simulation program capable of quickly allowing one to explore alternative geometries to determine the best arrangement of tracking detectors as a function of radius;
2. to identify specific “benchmark” physics analyses that help to establish the physics case for a CMS tracking trigger. The goal is to use these physics analyses to evaluate the performance of different trigger algorithms and use the performance metrics to select a baseline trigger design;
3. to undertake research in technologies that show promise of addressing some of the challenges listed above. For readout chips, these include ASIC technologies with smaller feature size than the  $0.25\ \mu\text{m}$  CMOS used in the current detector. For sensors, they include silicon with special processing to improve radiation hardness and the new materials and approaches listed above. One caveat is that the chosen technology must be mature enough at the time of construction that it is certain that the detector can be built on time and to meet its performance requirements. Technologies that offer little hope of achieving this level of maturity in time for construction should not be pursued; and
4. to carry out research into new methods of providing mechanical support, power and cooling, and lower mass cables and to study the tradeoffs between ideal coverage and ease of assembly.

## 2.4 Sensor issues

Research into improved sensors continued after the experiments made commitments to their sensor technologies [21] and CMS collaborators have been active in R&D projects. Some of the results suggest that silicon can meet radiation hardness requirements for the outer tracker, but they could require sensor manufacturers to adopt less widely used substrate materials, such as p-type silicon, or more innovative materials, such as magnetic Czochralski silicon. The cost issues associated with this and any need for, e.g., double-sided processing must be clarified. For the inner layers of a new tracker, it is not clear if sufficient radiation tolerance can be provided by any material and a strategy, either to replace layers at regular intervals, or adopt a new radiation hard sensor material must be defined.

Narrowing down of sensor options, in close collaboration with major manufacturers, will be required at an early stage, since specification of front-end electronics needs knowledge of signal properties and requirements for new cooling systems must be defined. It seems likely that dynamic range constraints will preclude design of amplifiers capable of handling both polarity signals. Leakage currents will be a major contribution to noise, as well as power, and the extent to which they can be controlled by lower temperature operation, as well as potential thermal runaway requires clarification. Signal speed and substrate doping changes have been controlled in part by high bias voltage operation to date; whether it is necessary or feasible to use even higher bias voltages in future must be understood.

Experience from LHC R&D illustrates the importance of working closely with the few major manufacturers who will be able to deliver large volumes of reliable, qualified sensors. Thus far, most of the prototyping of new sensors and materials in R&D projects has been based on small scale devices which are not yet representative of either the issues which will be encountered in mass production nor those which might be related to important details of actual sensor designs.

At least for the outer tracker, incremental gains in sensor performance will continue to be important. Qualification at the system level will be vital, and sufficient time must be left to allow revisions following early prototyping. Therefore, any sensor innovations must probably be limited to those which can reach large scale maturity in only a few years.

## 2.5 Electronic issues

CMS demonstrated over the last few years that  $0.25\ \mu\text{m}$  CMOS technology provided an excellent solution for on-detector ASICs, and it has been shown to be sufficiently radiation hard for the SLHC. However, it is expected to be commercially obsolete when an SLHC upgrade is undertaken. In more advanced processes, which are already in use, feature sizes and operating voltages have decreased considerably.

Although a few alternatives to CMOS have been discussed, notably Si-Ge technology, there are strong arguments to maintain the commitment to commercial CMOS, most likely with  $0.13\ \mu\text{m}$  feature size:

- CMOS radiation tolerance appears well in excess of SLHC requirements,
- Both analogue and digital designs are possible in the same technology, with adequate speed,
- There is considerable experience in the HEP community of CMOS design and significant benefits from sharing knowledge,
- The cost of engineering runs in all advanced processes is considerably higher than  $0.25\ \mu\text{m}$ , although large scale fabrication is likely to have a comparable, or lower, cost than the past. It will be important to plan prototyping, and share costs.
- Alternative technologies will require equivalent expertise to be gained and their performance is still to be demonstrated, which is likely to be costly and time consuming.

Use of smaller feature sizes will allow more functions to be incorporated into front-end chips, including deeper buffers, and lower power designs can be developed. However, there will be new challenges such as increased sensitivity to Single Event Upsets and reduced dynamic range of low voltage circuits. Operation at lower temperatures also requires increased attention to circuit performance. The present readout system provides analogue data, which proved to be immensely beneficial during prototyping and qualification, as well as offering benefits in position resolution when CMS operates. However, commercial electronic technologies are mainly digital, and the requirement for analogue data should be reconsidered and, if necessary an implementation matched to system needs, especially data transmission, should be implemented.

It is natural to choose a clock speed for digital electronics identical to the LHC beam crossing frequency which now seems likely to decrease from 40MHz to 20MHz, although this is not yet finally decided. It is crucial for development of a new readout system that the clock frequency is well defined at an early stage.

For off-detector electronics, the trend towards increased use of FPGAs is expected to continue. This will permit further development of flexible and more powerful data processing, which will be beneficial in handling the large tracker data volumes expected at the SLHC. However, constraints on underground rack space and heat removal probably imply that in-

creases in channel count should be accompanied by higher density boards, whose cooling will need careful engineering. Each board will probably need multiple outputs to deliver data to the DAQ switch, which will place additional pressure on board density. Irrespective of the detailed design of the tracker, data from each SLHC bunch crossing will contain more hits than at the LHC and most of them will be required for off-line track reconstruction. Thus the volume of tracker data to be transferred each second will increase substantially. Although the bandwidth of the switch matrix to the computer farm was a limiting factor in the original CMS DAQ design, such technology has already evolved considerably and commercial developments driven by consumer requirements are expected to meet CMS needs in future.

Two important items which must underpin development of a new tracker are optical links, and Timing, Trigger and Control distribution system, both of which are expected to be different for the SLHC. The 1.3  $\mu\text{m}$  edge-emitting single-mode laser technology pioneered by the CMS tracker for data transmission was adopted throughout the experiment, including for Gb/s links. It was used both for data transmission and control signals. Although it proved a good choice, optical technology has since evolved further, and cost and performance considerations motivate a review of a future system.

The TTC system requires upgrading to the SLHC clock speed, and must provide precise clocks for multi-Gb/s. It would be wise to build a system compatible with the optical distribution technology selected for data transmission, and to ensure that in future the TTC network could be extended into the tracker volume and avoid constructing a second internal control network.

Both TTC and optical link R&D could be undertaken as common SLHC developments, in collaboration with other experiments.

## 2.6 Power

Power consumption will remain a major concern and significant effort will be needed to solve this problem; there are several reasons:

- Channel numbers are expected to increase, so any gains from reduced front-end power consumption will be at least partially offset,
- Power dissipation by silicon sensors will be a far more significant contribution than the 10% expected at the end of LHC operation; this has yet to be quantified,
- Amplifier noise is closely related to transistor current, and low noise performance usually requires relatively high currents in the input transistor. There will be gains from reduced sensor lengths, but increased logic will consume more power, as will operation at higher clock speeds, especially for driving data links. This can only be quantified by building prototype chips,
- The volume available for cables and cooling services is strictly limited, and already congested; thus cable resistances will not decrease. Any increase in total current, which is likely to result from lower ASIC supply voltages, will increase voltage drops, and heat losses, in power cables,
- Increased cable voltage drops and finer feature processes imply increased vulnerability to ASIC overvoltages. The absence of internal voltage regulation in present

tracker systems is one factor; another is the risk of short circuits and inductive ringing which could be induced,

- Future systems are likely to require more pixel layers. Present pixel systems have considerably higher power density (  $5 \text{ kW/m}^2$ ) when compared to present microstrip systems (  $0.4 \text{ kW/m}^2$ ),
- Both power provision and heat removal add to the material budget, in the form of cables and cooling pipes. It seems that material scaling with power consumption is not linear, so if overall power reduction can be achieved, it is likely to have significant benefits for physics.

Two innovations have been suggested which could help reduce the scale of the problem: serial powering and DC-DC conversion inside, or near to, the tracker. Serial powering would connect modules in series, requiring different modules to be operated at different DC voltage levels. This raises a number of important questions, of which noise performance is only one, and a few studies have begun [22, 23]. DC-DC conversion would allow power to be brought in at higher voltage, but so far there has been even less work to investigate such power conversion inside the detector.

## 2.7 System issues

It is widely recognised that the effort necessary for sensor and electronic R&D to achieve the unprecedented levels of radiation hardness and robustness required for the LHC, as well as manufacturability, was considerable. Less time was originally envisaged to address system-scale issues, such as manufacture and assembly of front-end hybrids, distribution of power and rationalisation of cooling schemes. In most cases, these issues required at least as much attention as that devoted to sensors and readout components. In addition, only when system scale tests were carried out was it possible to address small points which emerged during qualification.

There will be new issues to address in future, some of which will depend on the success with other developments, such as reduced power consumption. Operation at lower temperature, which seems likely to be needed, presents several challenges, for heat removal and provision of pipes and services, validation of structures and materials, and qualification of components, especially including circuit operation. Sufficient time should be allowed in schedules to allow for unexpected features to emerge and be corrected.

## 2.8 Triggering using the tracker

To make tracker data available for use in the Level-1 trigger presents a major challenge. The readout architectures of both the present pixel and microstrip systems are not compatible with delivering tracker hits to the trigger system even with an increased latency of  $6.4 \mu\text{s}$  and data would be required much earlier than this to allow time for processing. Transferring large volumes of data at high speed would require considerable power so it seems likely that some amount of data processing on the detector will be required.

Few tracking trigger concepts have so far extended to full track reconstruction, although should this be feasible it would certainly improve performance. One approach which might

achieve this makes use of associative memories, which has already been demonstrated in CDF [24]. It makes use of binary readout in the front end electronics, followed by transfer of the full granularity data off detector using optical links to dedicated processors which reconstruct tracks.

To limit the overall L1 rate it may be sufficient to associate track elements pointing to significant energy deposits in the ECAL, for example. Since even under high occupancy conditions it is not likely there will be a high rate of such track stubs pointing accidentally to triggering calorimeter towers, it could be enough to reconstruct elementary tracks in a small number of layers originating from a primary vertex compatible with a beam interaction. However, even this is far from simple, since it implies associating data from different tracker layers, and eliminating stubs from low transverse momentum tracks.

One promising concept uses two layers of small pixels in close radial proximity to each other so that coincidences of hits between the two layers amount to a track transverse momentum cut[25]. This reduces the large amount of low-momentum data while keeping the tracking efficiency very high for high- $p_T$  tracks. The double layer could be located in the region between the present pixel system and the innermost microstrip layer. A practical design needs to be developed to study this idea more deeply.

Among the issues to be confronted are not only the challenges of building radiation hard pixel sensors and readout, but data transfer and processing on the detector and the power requirements.

## 2.9 Roadmap for a tracker upgrade

To develop more concrete proposals, the tracker proposes to set up a number of working groups with specific objectives, steered by a central team. At the top level, there will be definitions of targets for a new tracker, which will include outline specifications of:

- targets for cost, material budget and power consumption
- expected radiation level requirements and operational lifetime
- guide parameters for definition of outer tracker, including sensor material
- major operational conditions, such as temperature and need for analogue information

The proposed working groups will include the following subjects and major objectives:

- **Performance and detector layout**, to estimate the granularity needed to achieve the required tracking performance, to quantify the material budget breakdown and identify where significant gains could be achieved and potential improvements in physics performance, and using guidelines for likely cost, power and material budget, to define boundary between inner and outer tracker.
- **Sensor material and operation**, to recommend sensor material and expected sensor parameters for outer tracker, to investigate sensor options for inner layers and further R&D requirements, to define operating conditions for outer sensors, including bias voltage, expected leakage currents and environmental requirements, and investigate prototyping of outer tracker sensors with industry and recommend options to be pursued.

- **Outer tracker readout system definition**, to define requirements and specifications for a new readout chip, to investigate front-end connection and assembly technology, to identify requirements for TTC and control system, and optical links, and to outline a new readout and control system.
- **Pixel system and triggering**, to review the present system and advise what significant developments are needed to gain improvements in performance and lifetime, to recommend R&D on further pixel developments, to recommend sensor materials to be studied for inner layers and further R&D requirements, to define a readout system architecture and propose options for triggering layers.
- **Manufacture and material budget**, to investigate present and alternative cooling schemes to identify what systems are possible, to investigate new materials and support structures for prototype modules, and begin to prototype modules for improved ease, speed and reliability of assembly.

## Chapter 3

# SLHC Trigger and Data Acquisition

### 3.1 Introduction

The CMS trigger and data acquisition systems (TRiDAS) will need significant modifications to operate at the SLHC design luminosity up to ten times the LHC design luminosity of  $10^{34} \text{cm}^{-2} \text{s}^{-1}$ , possibly with a crossing frequency half the present 40 MHz. Due to the increased occupancy of each crossing, at the SLHC Level-1 trigger systems would experience degraded performance of the LHC algorithms presently planned to select the 100 kHz of crossings from the input rate of 40 MHz. The electron isolation algorithms would experience reduced rejection at fixed efficiency and the muon trigger would experience increased background rates from accidental coincidences. The DAQ system would experience larger event sizes due to greater occupancy. If new, higher channel-count trackers replace the existing ones, then the increase would be greater. This would reduce the maximum Level-1 trigger rate for a fixed readout bandwidth.

#### 3.1.1 TriDAS Goals

The goal of the CMS SLHC TriDAS system is to enable a physics program with integrated luminosity roughly ten times that of the LHC or about  $3000 \text{fb}^{-1}$ . The priority for the CMS SLHC TriDAS system is to capture the physics of the SLHC with the highest efficiency possible at acceptable detector readout and data storage rates.

#### 3.1.2 TriDAS Performance

In order to meet the challenges of SLHC operation the suggested approach is to hold the overall Level-1 trigger rate at the LHC value of 100 kHz while increasing the readout bandwidth. This approach avoids rebuilding front-end and readout electronics as much as possible since these were designed for an average readout time of less than  $10 \mu\text{sec}$ . It also permits use of front-end buffers for an extension of the Level-1 Accept (L1A) latency rather than for more post-L1A storage before readout. However, maintaining a 100 kHz L1 rate at the SLHC will increase the burden on the DAQ, which will need to transport more than the anticipated LHC data size of 1.5 MB per event.

Holding the L1 trigger rate to 100 kHz at the SLHC without improving the trigger system implies raising  $E_T$  thresholds on electrons, photons, muons and jets, as well as the use of less inclusive triggers. Such strategies assume that with several years of data accumulated at the LHC design luminosity before the SLHC upgrade, many of the physics studies requiring lower  $E_T$  thresholds would have sufficient statistics and that the physics at the LHC would



be sufficiently understood to provide the necessary understanding of efficiency for more complex trigger configurations. However, for searches for rare events or attempts to make precision measurements, there would be a substantial loss of physics performance.

### 3.1.3 TriDAS SLHC Strategy

The goal of the upgrade of the CMS TriDAS is more than mere survival during SLHC operation with a comparable performance to that experienced at the LHC. The intent is to exploit the evolution in technology since the original TriDAS design and the experience of building and operating CMS at the LHC. The purpose is to significantly enhance the capabilities of the SLHC TriDAS to provide a level of performance that ensures the greatest access to physics signals.

The strategy for upgrading TriDAS follows the present strategy of TriDAS evolution during LHC running of first operating any hardware Level-1 (L1) trigger virtually in the Filter Farm Higher Level Trigger (HLT) code using emulation compared with the data read from the L1. During the first phase of CMS LHC operation, the L1 algorithms involve data from the calorimeter and muon systems. Once the reduction power of these subsystems is fully exploited, the next step is to use tracking information. It is our intent to explore using the tracking information in the L1 to further extend the physics reach of CMS for the SLHC.

## 3.2 SLHC Trigger Operation

### 3.2.1 Crossing Frequency

The operation of the SLHC at a bunch crossing frequency of 20 MHz instead of 40 MHz will increase event pile-up, decrease trigger algorithm performance, and increase data volume for detectors that have time resolution sufficient to identify data associated with individual 25 ns bunch crossings. Since running the SLHC at 40 MHz will be retained as an option to mitigate these difficulties, we require that all CMS detector and electronics designs for SLHC upgrades work with a 25 ns bunch spacing and handle an occupancy consistent with  $\mathcal{L} = 10^{35} \text{ cm}^{-2} \text{ s}^{-1}$  at 50 ns bunch spacing.

Operating the SLHC with 50 ns bunch crossing spacing at  $\mathcal{L} = 10^{35} \text{ cm}^{-2} \text{ s}^{-1}$  implies a pileup 300-400 min-bias events/crossing. This is a factor of more than 20 greater than the LHC design luminosity ( $\mathcal{L} = 10^{34} \text{ cm}^{-2} \text{ s}^{-1}$ ) figure of 17 min-bias events per crossing and will degrade all occupancy-dependent trigger algorithms that rely on forms of isolation to identify electrons, muons,  $\tau$ 's and missing energy signals. It will require a more performant trigger with additional information, such as tracking data, used to reduce the trigger rates against the much higher backgrounds. The size of regions sampled for trigger decisions will need to shrink to handle the increased backgrounds. These are the guiding principles upon which we base our design of the SLHC trigger system for CMS.

### 3.2.2 Trigger Thresholds

The CMS trigger system has three major physics performance requirements. First, it needs to be efficient for high- $p_T$  discovery physics. If the raising of thresholds results in a substantial

rate reduction, then this can be satisfied since these thresholds are high. Second, it needs to provide high statistics for topics such as precise measurements of the Higgs sector. This requires low thresholds on leptons, photons and jets. This can be partially addressed by the use of more exclusive triggers rendered usable by the previous years of understanding final states observed at the LHC, provided that the introduction of these more exclusive triggers does not introduce more systematic errors. Finally, the trigger needs to provide control and calibration triggers. These are samples such as W, Z and top events. Such low-threshold triggers can be held to an acceptable rate by prescaling, which should yield more than adequately sized samples.

An initial study of the L1 trigger thresholds for the SLHC [11] suggested inclusive single muon and electron thresholds of 30 and 55 GeV with rates of 25 kHz and 20 kHz respectively. Electron and muon pair thresholds of 30 and 20 GeV respectively are predicted to have rates of a few kHz, from present LHC-based simulations. Inclusive Jet and missing  $E_T$  thresholds of 350 and 150 GeV, respectively would produce rates of about 1 kHz. The actual triggers employed might use less inclusive conditions to access lower thresholds.

### 3.2.3 Trigger Rates

The ability of the CMS L1 trigger to reach the above SLHC performance goals depends on many factors and is not necessarily achievable with the present LHC trigger information. An example is the CMS muon trigger. The single muon trigger rates as a function of the  $p_T$  threshold are shown in Figure 3.1 for LHC design luminosity ( $10^{34} \text{cm}^{-2} \text{s}^{-1}$ ). The rates are shown separately for Level-1 (L1 Trigger information only), Level-2 (HLT reconstruction using full-resolution muon system data only with isolation calculated from full-resolution calorimeter data), and Level-3 (HLT track momentum and isolation calculated from silicon strip and pixel tracking data), with and without isolation applied at Levels 2 and 3. Also shown is the single muon rate that was generated in the simulation. A threshold of 31  $\text{GeV}/c$  reduces the single-muon Level-3 rate to 50 Hz with isolation (100 Hz without isolation).

In Figure 3.1 the Level-2 rates have a reasonable reduction with increasing muon  $p_T$  cut up to 20  $\text{GeV}/c$ , where the rate is 200 Hz. Above a  $p_T$  of 20  $\text{GeV}/c$ , the reduction of rate with increasing muon  $p_T$  cut is very slow, dropping only a factor of 2 with an increase in  $p_T$  cut up to 60  $\text{GeV}/c$ . Therefore if we bring the full Level-2 algorithm performance (without tracking) to bear in Level-1 for the SLHC, this shows that above a  $p_T$  threshold of 20  $\text{GeV}/c$  the only effective method to reduce the rate with increasing threshold is to use Level-3 algorithms which involve tracking. This motivates examining the use of tracking information in the SLHC L1 trigger.

## 3.3 SLHC Trigger Primitives

### 3.3.1 Calorimeter and Muon Triggers

The existing trigger primitive information used by the L1 trigger systems needs examination to determine adequacy for use at the SLHC. For the calorimeter, the forward quartz fibre detector might require finer-grained information to provide a smaller trigger tower size. The HCAL and ECAL have sufficient time and spatial resolution for SLHC operation, using their present 40 MHz sampling without significant modification. However, replacement of the

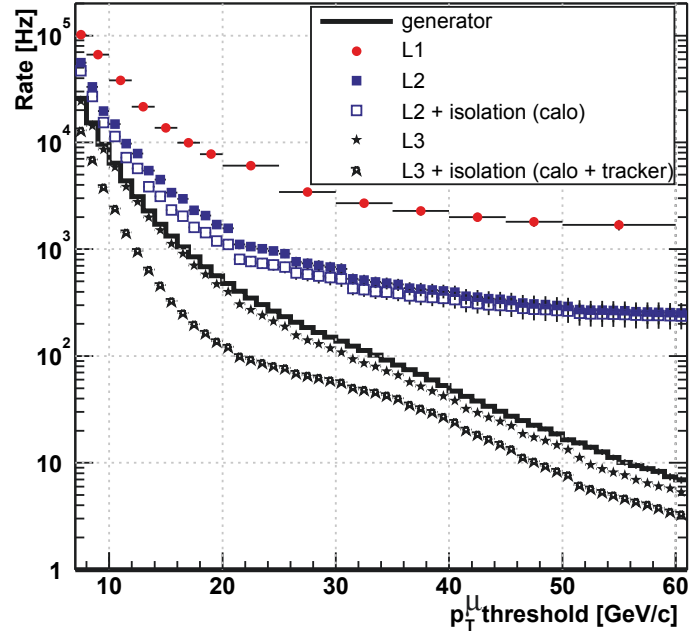

Figure 3.1: The HLT single-muon trigger rates as a function of the  $p_T$  threshold for a luminosity of  $10^{34} \text{ cm}^{-2} \text{ s}^{-1}$ . The rates are shown separately for Level-1, Level-2, and Level-3, with and without isolation applied at Levels 2 and 3. The rate generated in the simulation is also shown[26].

endcap ( $1.5 < \eta < 3$ ) calorimetry may be needed due to radiation damage. The muon system RPCs may not function at the SLHC luminosity, particularly at high  $\eta$  in the endcap. The barrel muon system drift tube chambers could continue to operate at 40 MHz, with increased backgrounds that could be reduced by combination with a Level-1 tracking trigger. The endcap muon system Cathode Strip Chambers will probably continue to be usable for triggering at the SLHC with some improvements and higher thresholds.

### 3.3.2 Tracking Triggers

A possible source of trigger primitives not presently used in the CMS L1 trigger system is the tracker. This would most likely require a replacement of the tracking system and a change in technological solution. However, it is also likely that operation at the SLHC will require replacement of the CMS tracking system. Therefore it is worth considering what form tracking trigger primitives might take and how they might be used. CMS has the provision for a type of L1 tracking trigger using the z-vertex positions of pixel clusters of high hit occupancy in  $\Delta\eta \times \Delta\phi$  bins. This could be used to reject jets from pile-up events since their z-vertices would not line up with the main event z-vertex. At present the logic for this is not implemented, but retained as an option.

A L1 tracking trigger could provide either an inner track or an outer stub or both. These would be used to combine with the calorimeter at L1 to reject  $\pi^0$ s and reject jets from pileup. They would be used to sharpen  $p_T$  thresholds and reduce accidentals and wrong crossing determinations in the muon system. Implementation would not only require rebuilding the tracker, but also rebuilding the calorimeter and muon trigger systems to various degrees in order to provide outputs with suitable granularity and other information to combine with

the L1 tracking trigger.

## 3.4 SLHC Trigger Algorithms

### 3.4.1 Tracking Trigger Algorithms

The most effective method to significantly improve trigger functionality for the SLHC may be to employ tracking at the earliest stage possible. In order to evaluate the effect of tracking on trigger performance, it is appropriate to examine how tracking is first used in the CMS HLT since these are the candidate algorithms for migration to L1. As an example, attaching tracker hits to muon tracks improves the  $p_T$  assignment precision from 15% for the endcap muon system stand-alone to 1.5% with the tracker information included [26]. This also improves the sign determination and provides a vertex constraint. In addition, pixel tracks are found within a cone around the muon track and their sum  $p_T$  is used as an isolation cut. This is less sensitive to pile-up than calorimetric information if the primary vertex can be determined. The combination of tracking  $p_T$  resolution and isolation provide more than an order of magnitude reduction in the CMS L1 muon trigger rate as shown in Figure 3.1. To implement such a trigger at L1 in CMS would require information on muon track locations on a  $(\eta \times \phi) = (0.0125 \times 0.015)^\circ$  for adequate correlation with the tracker. While finer than the present CMS  $(\eta \times \phi) = (0.05 \times 2.5)^\circ$  trigger scale, this information is already available but not used.

Tracking information in the HLT also reduces the CMS L1 calorimeter trigger rate. As shown in Figure 3.2 the correlation of an electron trigger with an extrapolated pixel track reduces the rate by a factor of 10. Tracking information is also used as an isolation cut for photon candidates. As shown in Figure 3.3 the CMS L1 calorimeter jet-based  $\tau$ -lepton trigger is also reduced a factor of 10 by requiring isolation using pixel tracks outside the signal cone and inside an isolation cone. In order to use the information from a tracking trigger at L1, the calorimeter trigger  $e$ ,  $\gamma$  and  $\tau$  objects could be used to seed tracks with the full calorimeter trigger tower  $0.087\eta \times 0.087\phi$  granularity. Candidates could be pre-sorted and limited to a maximum number, such as 32. A single track match within a  $3 \times 3$  trigger tower region with a coarse  $p_T$  resolution (8-bit scale with 1 bit/GeV) could be sufficient to reduce the electron trigger rate. A veto of tracks in the  $3 \times 3$  trigger tower region would be used for a veto of photon candidates and a single or triple track match would be used for  $\tau$  candidates.

### 3.4.2 Calorimeter Trigger Algorithms

Other upgrades to the CMS calorimeter trigger would be needed to reduce the jet and missing energy trigger rates. These would include allowing the clustering of jets in multiples of  $2 \times 2$  trigger towers:  $6 \times 6$ ,  $8 \times 8$ ,  $10 \times 10$  with a sliding window making one or two tower steps and use of higher resolution scales with more precise geometry for missing energy. All of these changes to the CMS L1 calorimeter trigger would represent a reasonable extension of the present system. Technological advances in FPGAs and data links would permit processing of high speed serial data such as 32 10 Gbit/s links per card with high speed serial output in the 4–10 Gbit/s range.

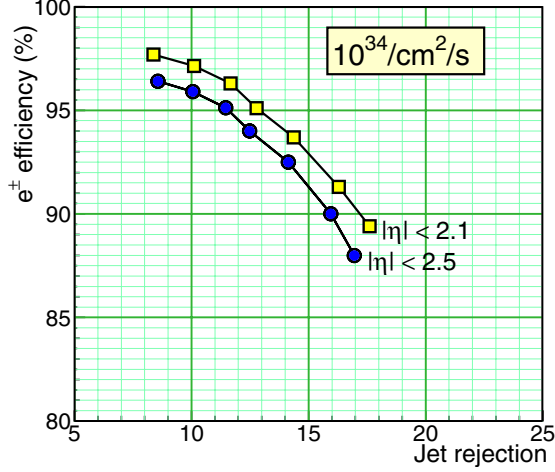

Figure 3.2: Electron HLT rejection versus efficiency[26] from pixel matching for a luminosity of  $10^{34} \text{ cm}^{-2} \text{ s}^{-1}$  for two different  $\eta$  ranges.

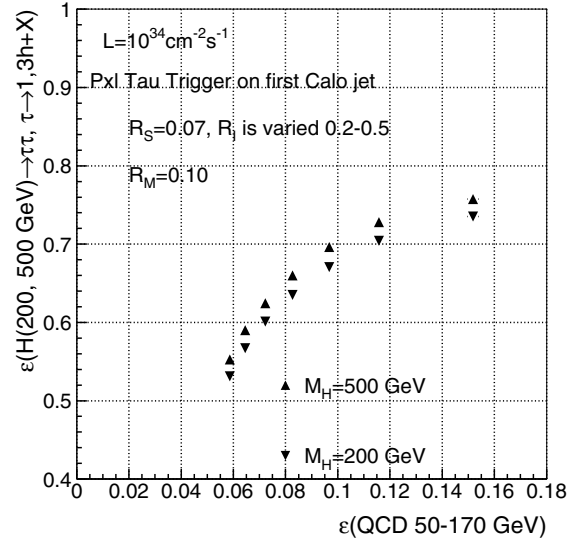

Figure 3.3: Efficiency of pixel track  $\tau$  HLT[26] cut on the first calorimeter jet in  $A^0/H^0 \rightarrow 2\tau \rightarrow 2\tau - jet$ , for two Higgs masses,  $M_H = 200$  and  $500 \text{ GeV}/c^2$ , versus the efficiency for QCD di-jet background events for a luminosity of  $10^{34} \text{ cm}^{-2} \text{ s}^{-1}$ .

### 3.5 SLHC Trigger Architecture

The implementation of the new algorithms involving tracking discussed above would require modification of the CMS trigger architecture. The present CMS architecture provides a flow of data within the muon and calorimeter trigger systems from regional to global components into the CMS Global L1 trigger. For the SLHC the L1 trigger data would need combination between tracking and calorimeter and muon triggers at a regional level with finer granularity than presently employed. After this regional correlation stage, the physics objects made from tracking, calorimeter and muon regional trigger data would be transmitted to the global trigger. The important new feature is that some of the tracking, isolation, and other regional trigger functions would be performed in combinations between regional triggers in a new hardware layer composed of regional cross-detector trigger crates as shown in Figure 3.4. An advantage of this architecture is that it would leave the present CMS L1 and Higher Level Trigger (HLT) structure intact by not adding additional trigger levels. This minimizes the impact on the CMS readout.

### 3.6 SLHC Trigger Latency

The additional layer of processing for combination of tracking information, increased algorithm complexity and larger trigger data volume due to finer trigger granularity suggest an extension of the present CMS  $3.2 \mu\text{s}$  L1 latency. A longer latency would also be needed for use of FPGA embedded serializers and deserializers, the addition of more serialization and deserialization steps to use high speed serial links or the use of buffers to incorporate commercial serial links running asynchronously with respect to the LHC clock. The CMS

L1 latency is limited by the front-end analog storage capacity of the tracker and preshower electronics. Since it is expected that these detectors will be replaced for the SLHC, it is reasonable to assume that their electronics will also be replaced and that this limitation can be removed. The next limitation is the ECAL digital memory depth of 256 40 MHz samples corresponding to time of  $6.4 \mu\text{s}$ . This is proposed as the CMS SLHC L1 latency baseline.

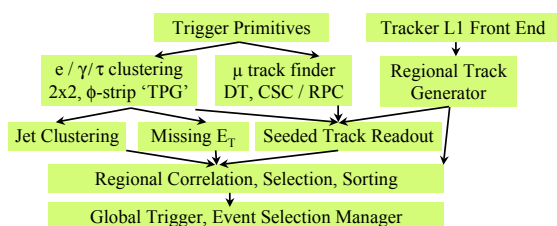

Figure 3.4: Schematic of SLHC L1 Trigger

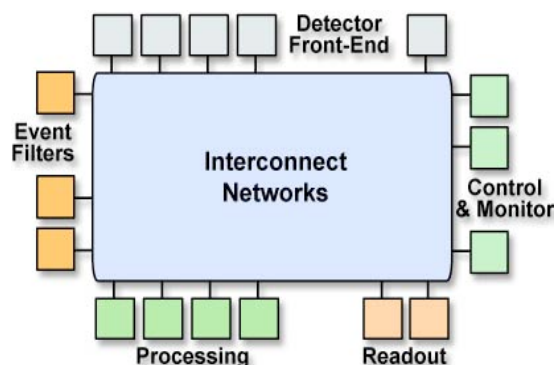

Figure 3.5: Schematic of SLHC DAQ

### 3.7 SLHC DAQ

If one assumes that the L1 trigger rate remains at 100 kHz, the increased channel occupancy and finer detector granularity, leading to a larger channel count, suggest a bandwidth requirement for SLHC DAQ systems at least 5–10 times that of the present LHC DAQ systems. The present CMS LHC DAQ uses a network with Terabit/s aggregate bandwidth constructed from two stages of switches and a layer of intermediate data concentrators for optimizing traffic load to the event builder. The capacity of the buffer memories of 100 GB between the front-end readout and the event builder permit a real-time DAQ latency of seconds. A proposed architecture for the CMS SLHC DAQ is shown in Figure 3.5. The concept is to incorporate as much of the DAQ functionality as possible into a commercial network of the capability one can expect from industry in the next decade. This incorporates a scalable multi-Terabit/s network to interconnect all of the elements. The function of the Event Manager (EVM) is incorporated into the L1 trigger. The EVM updates the list of available event filter services where events are to be sent for processing. Along with the L1 accept, the trigger transmits additional information to the front ends including the event type for post L1 processing and the destination address of the event filter node where the resident event fragment is to be transmitted. This requires the control logic to process and transmit instructions at the 100 kHz L1 trigger rate to every readout, trigger event filter and other element of the DAQ. The event fragment delivery and the event building itself are provided by the network protocols using the commercial network hardware. This design allows for real-time buffers consisting of Pbytes of storage disks, which would permit storage of events being processed over a period of days. This opens up the possibility of using non-local compute nodes and GRID tools to maximize access to remote resources in a flexible manner.

### 3.8 SLHC Trigger and DAQ R&D

### 3.8.1 TTC Upgrade

An important development needed for the proposed CMS SLHC DAQ architecture outlined above is a revision of the existing Trigger Timing and Control (TTC) system [27] to transmit and receive added fast control information. A new TTC system should provide the clock, L1 Accept, Reset, Bunch Crossing 0 and trigger type information in real time for each crossing. An R&D effort would be required for the TTC system clock signal so that it can meet the jitter and other requirements to drive the new generation of high-speed serial links, as well as to be capable of functioning at the GHz frequency needed to meet the fast message distribution needs of SLHC trigger and DAQ.

### 3.8.2 Trigger Upgrade

The substantial increase in algorithm complexity and volume of data they need should be met by industrial development of Field Programmable Gate Arrays (FPGA) promising faster devices with higher logic gate counts and increased I/O. Of note is the advent of embedded GHz serializers and deserializers on the FPGA inputs and outputs, enabling very high throughput. However, the latency of these circuits remains a concern and needs study. The use of these devices is becoming more challenging in terms of packaging, routing, mounting, and low supply voltages. R&D on the use and performance of these rapidly evolving devices is needed for development of SLHC trigger systems. The need to move larger quantities of data at higher speed requires R&D on high-speed serial links and backplane technology, as well as on the clocking systems needed to drive them with low jitter.

### 3.8.3 DAQ Upgrade

The CMS DAQ system will also depend on are progress in backplane and data link and technologies, which will need to incorporate the newer frequency 40 GB links and protocols. The much tighter integration of front-end electronics and the links needed suggests that R&D on these be done together. The front-end electronics will have many challenges for R&D to handle the increased processing and channels counts. While improvements in VLSI technologies should provide the necessary components, there are many R&D issues such as radiation tolerance, power reduction, system complexity, and integrating the commercial data communications developments. The DAQ system itself also faces a considerable challenge of managing the complexity caused by the increasing numbers of components, operations and stages of processing. This will require R&D on more sophisticated controls and diagnostics. One path is to exploit as much as possible industrial developments in this area.

As the L1 trigger adopts more sophisticated algorithms that were formerly used in the HLT and the backgrounds for the HLT algorithms increase, the HLT algorithms must become much more sophisticated. This will require considerable study, physics simulation and eventually physics analysis of LHC data to determine the initial set of HLT algorithms.

## Chapter 4

# Upgrades to the Calorimeters

The barrel regions of the electromagnetic (ECAL) and hadronic calorimeters (HCAL) are designed to be able withstand the expected integrated luminosity at the SLHC. There should be no need to replace on-detector electronics, although changes may need to be made to off-detector electronics to accommodate a new trigger and DAQ system. The endcap calorimeters may suffer reduced performance at high luminosities, but the on-detector electronics should continue to operate.

### 4.1 ECAL issues for SLHC

#### 4.1.1 ECAL detectors

The ECAL Lead-Tungstate crystals have been tested to radiation doses in excess of what is expected for running at the SLHC, and are expected to operate well, albeit with somewhat reduced light yield. The VPTs in the endcap calorimeter may also suffer some darkening at very high luminosity. The efficiency of the PreShower detector which lies in front of the ECAL endcaps will need to be studied, although the detectors and electronics should in principle continue to operate.

#### 4.1.2 ECAL electronics

The front-end electronics for the ECAL is mounted directly behind the crystals and is not easily servicable. All components have been tested to operate at radiation levels exceeding that expected at the SLHC. The most sensitive components are the low voltage regulators, which may require running at a higher voltage drop in order to operate after very high integrated fluences. This is most likely to affect the endcap as the barrel will see a significantly lower fluence.

The front-end digitization will continue to operate at 40 MHz. This is not a problem for machine operation at 20 MHz as the full signal waveforms are digitized and transmitted off-line where bunch identification can be determined. The ECAL also forms trigger primitives for the Level-1 calorimeter trigger, and the electronics has provided for the ability to calculate trigger primitives for two bunch hypothesis at each 40 MHz sampling, hence be able to provide trigger information even for 80 MHz running should this option reemerge.

Off-detector electronics would need to be updated to cope with any changes in the bunch crossing frequency, and changes to the Trigger and DAQ system.



## 4.2 HCAL issues and R&D for the SLHC

The HCAL is largely immune to the changes in environment between the LHC and the SLHC. There are several issues that are of concern and are being addressed. The high eta region of the endcap hadronic calorimeter (HE) will suffer extensive radiation damage requiring replacement. Improvements in MIP recognition in the outer hadronic calorimeter (HO) will be desirable. The main issue with the forward hadronic calorimeter (HF) is whether it will be obstructed by elements of the machine placed inside CMS which could potentially be required to increase the focusing strength of the machine. Finally the HCAL readout electronics may need to accommodate higher bandwidth in readout and finer trigger primitive granularity. These issues are being studied.

### 4.2.1 Radiation resistant replacement for high eta HE scintillator

In the current design, HE uses plastic scintillator tiles and wavelength shifting fiber. These materials have been shown to be moderately radiation hard up to the 2.5 Mrad limit expected from 10 years operation of the LHC. Under the SLHC conditions the lifetime radiation dose at the HE will increase from 2.5 Mrad to 25 Mrad. The scintillator tiles used in the current design of HE will lose their efficiency due to high radiation. They will need to be replaced with new devices that fit in the geometric constraints of the existing absorber structure. There are several possible solutions, including new scintillators, parallel plate chambers, silicon sensors, and quartz plates that generate cerenkov light rather than scintillation light. Each of these solutions is being pursued.

Parallel plate chambers (PPAC) have been built and tested. Large-area PPACs have a thin HV plate suspended between two grounded plates. A PPAC can be made entirely of metal and ceramic that is unaffected by radiation. Aging is prevented by suitable additives to the gas and by gold plating the inside surfaces. The output signals are connected directly to 50  $\Omega$  coaxial cables so that all of the electronics can be located in a remote region.

Another alternative is to replace the scintillators with quartz plates and the waveshifting fibers with rad-hard (possibly inorganic) waveshifter. The cerenkov light produced in the quartz is about 100 times less than scintillation light. One goal of this R&D is to optimize the light yield by careful placement of the wavelength shifters. The HCAL group has built small calorimeters based on this technology and tested them in the CERN testbeam during the Fall of 2006.

Silicon sensors are also being considered as a replacement. This idea would use radiation resistant silicon sensors to replace the scintillators in the highest eta region of HE.

### 4.2.2 New photodetectors

The HCAL community is actively studying silicon photomultipliers (SIPM) as a replacement for the HPDs in the HO region. It is estimated that SIPMs can give a factor of 4 larger signal to noise, which is critical for improved muon and MIP identification with this detector. A prototype readout using SIPMs has been built and tested in CERN testbeams in September 2006.

### 4.2.3 New electronics

The HCAL group is engaged in design studies of new electronics to improve the readout speed into the DAQ, and improve trigger granularity for future enhanced calorimeter triggers.



## Chapter 5

# Upgrades to the Muon Systems

### 5.1 R&D topics for the SLHC

The CMS muon detector is composed of Drift Tube chambers (DT) in the barrel region, Cathode Strip Chambers (CSC) in the end-cap regions, and Resistive Plate Chambers (RPC) both in barrel and in end-caps.

They have been designed for tolerating hit rates a few times larger than those expected at LHC. They seem still adequate for use at the SLHC, although more R&D work and LHC data is necessary to substantiate that possibility, in particular for the larger rapidity regions.

Major upgrades will definitely be needed for front-end electronics, trigger and readout electronics, in order to cope with the larger hit rate and to tolerate the SLHC radiation background and, for digital electronics, to adapt to the SLHC bunch crossing frequency.

The CMS RPC system is divided in two regions: barrel ( $0 < \eta < 1.2$ ) and endcap ( $0.9 < \eta < 2.4$ ). The expected total rate goes from 5–10 Hz/cm<sup>2</sup> of the barrel region up to 1 kHz/cm<sup>2</sup> of the very forward endcap region ( $\eta > 2.0$ ).

RPC chambers have been exposed at the GIF gamma radiation for more than two years in order to study possible long-term ageing effects. A total charge corresponding to about 15 CMS years has been integrated during the GIF test.

During the test no significant degradation of the chamber performances has been observed and after 15 CMS years the noise rate was less than 5–10 kHz/cm<sup>2</sup>. The rate capability of about 1 kHz/cm<sup>2</sup> was stable during the test.

The front-end electronics has been tested with neutrons at reactors showing an average time between SEU events of less than 1 h/RPC corresponding to a rate of *false hit*  $< 0.27$  mHz. At the GIF the front-end electronics showed a very stable performance during the whole test.

Assuming backgrounds at the SLHC were a factor 10 higher than the LHC, the CMS RPC chamber and their electronic front-end are potentially adequate for use in the barrel region and in the first end-cap station. More difficult is the larger rapidity end-cap region where the estimated background at the LHC is 0.1–1.0 KHz and where an additional factor 10 on the background would bring the operation very close to the RPC rate limit.

In the DT system, on-chamber trigger electronics uses a mean timing technique for generating a *high-p<sub>T</sub> muon* signal for triggering CMS on a LHC specific bunch crossing (BX). Operation at 20 MHz as opposed to the current 40 MHz should not represent a problem.

In the CSC system, the ME4/2 chamber has to be restored for the reliable trigger operation

and improved coverage. It is expected that the ME4/2 will be recovered by  $\approx 2009$ –2010 for the nominal luminosity phase of the LHC, before the SLHC. It has been shown that the electronics, as currently designed, would function at the SLHC. However this statement should be reevaluated after experience with data proper. We do wish to evaluate whether any of the on-chamber electronics would benefit from advances in technology that have taken in place sufficiently to warrant replacement. Given that the trigger and timing will be significantly different in the SLHC era (for example an asynchronous trigger is a real possibility), it is highly likely that we will replace elements of the trigger path. The Clock and Control Board will inevitably be replaced. Exactly which boards should be redesigned and what the elements of the new design should be the subject of study.

The DAQ path in CSCs may benefit from modifications. In particular the FED crate makes use of the TTC chip and may consequently need modification or replacement. Whether other elements of the DAQ path would benefit replacement will be studied. The adequate radiation tolerance of the on-detector electronics has to be confirmed in realistic beam conditions and with realistic shielding, and depending on the result, R&D on developing more radiation tolerant electronics may become necessary.

## Chapter 6

# Project Office

Implementation of the CMS SLHC Upgrades will be coordinated through a SLHC Project Office. This will be closely integrated with the CMS Technical Coordination.

### 6.1 Changes to the Infrastructure

One of the key areas which the project office will have to coordinate are any changes to the CMS interaction region which are mandated by changes in the machine. These may include changes to the insertion triplets which require substantial changes to the rotating shielding and TAS, as well as potential placement of magnetic elements into the UXC55. Either of these changes may require significant changes to shielding, beampipe design, and the detectors in the forward regions of CMS

Also important will be understanding how to remove and replace the first generation CMS detectors which will potentially be highly activated.

The project office will keep the schedule of upgrade work, and organization of installation and infrastructure work.

### 6.2 Organization of Upgrade work

The CMS Management and Collaboration Boards approved the creation of a CMS SLHC Upgrade Steering Group [28] in September 2005. This group was mandated to:

- recommend R&D proposals for approval to CMS Management and Collaboration Boards,
- plan SLHC workshops,
- provide outreach to collaboration on SLHC activities,
- interact/Co-ordinate with Machine and ATLAS on SLHC matters,
- report regularly to the CMS Management and Collaboration Boards.

Each CMS sub-detector has nominated a representative to this steering group, and these act as liaisons with their detector upgrade communities. The current process for R&D proposals is for sub-detector groups to discuss the potential upgrade R&D, and then submit a proposal to the steering group. These proposals will be reviewed by the steering group and then recommended to the CMS Management and Collaboration Boards. It is expected that proposals will be summarized for the LHCC.

In order to prepare for and focus the needed R&D efforts, a series of four upgrade workshops have been held[19]. These workshops have been used to understand the potential upgrades, identify key areas of research, and communicate information on the upgrades to the CMS community. Future workshops will focus on identifying potential common R&D (across LHC experiments), and more detailed planning of upgrades.

### 6.3 Cost Estimates and timescales

Preliminary estimates of the costs for the expected upgrades are shown in table 6.1. These estimates are for the material costs, and do not include personnel. The estimates are based on extrapolation from the costs of the current CMS detector components, and assume a complete replacement of the tracking and trigger systems.

Table 6.1: Estimated costs for SLHC detector upgrades (in Million Swiss Francs). These costs are for materials only for construction, and do not include R&D costs

Sub-Detector	Estimated Cost
Inner Tracker	30 MCHF
Outer Tracker	90 MCHF
Level-1 Trigger	20 MCHF
DAQ	10 MCHF
Muons and Calorimeters	10 MCHF
Infrastructure	15 MCHF
Total	175 MCHF

The CMS strategy for upgrades is planned to proceed in two steps. In the first step, new layers of tracking detector which contain some elements capable of participating in the Level-1 Trigger decision are inserted within the volume of the current Pixel detector. These would be used as a technology demonstrator of the key elements of the upgrade, and could be installed during a normal winter shutdown.

The second step of the upgrade would be full replacement of the tracking and trigger systems, as well as required upgrades to the DAQ and other systems. This step would most likely take more than one year and would take place during the long shutdown required for upgrading the LHC machine. A notional timeline for the upgrade steps can be seen in Figure 6.1.

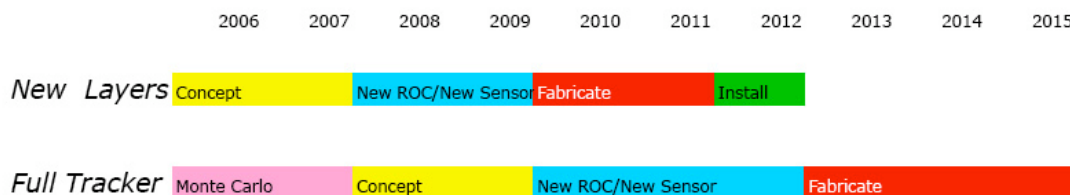

Figure 6.1: Timeline for steps involved in the tracker upgrade.

# References

## Notes:

- a) CMS Notes are available at <http://cms.cern.ch/iCMS/> unless otherwise noted.
- b) References marked **doi** should be prefixed with <http://dx.doi.org/>.

- 
- [1] T. L. S. Group, "The Large Hadron Collider Conceptual Design," *CERN-AC-95-05* (1995) [arXiv:hep-ph/0601012](https://arxiv.org/abs/hep-ph/0601012).
  - [2] CMS Collaboration, "The Compact Muon Solenoid Letter of Intent," *CERN/LHCC 1992-3* (1992). LHCC/I 1.
  - [3] CMS Collaboration, "The Compact Muon Solenoid Technical Proposal," *CERN/LHCC 94-38* (1994). LHCC/P1.
  - [4] **ATLAS and CMS** Collaboration, J. G. Branson et al., "High transverse momentum physics at the Large Hadron Collider: The ATLAS and CMS Collaborations," *Eur. Phys. J. direct C4* (2002) N1, [arXiv:hep-ph/0110021](https://arxiv.org/abs/hep-ph/0110021).
  - [5] **LHC/LC Study Group** Collaboration, G. Weiglein et al., "Physics interplay of the LHC and the ILC," [arXiv:hep-ph/0410364](https://arxiv.org/abs/hep-ph/0410364).
  - [6] N. Krasnikov and V. Matveev, "Search for new physics at LHC," *Phys. Usp.* **47** (2004) 643, [arXiv:hep-ph/0309200](https://arxiv.org/abs/hep-ph/0309200).
  - [7] W. Scandale, "LHC luminosity and energy upgrade," in *Proceedings of EPAC 06 Edinburgh*. 2006.
  - [8] W. Scandale, "Possible scenarios for the LHC luminosity upgrade," *Nucl. Phys. Proc. Suppl.* **154** (2006) 101–104.
  - [9] F. Ruggiero, W. Scandale, and F. Zimmermann, "Second CARE-HHH-APD Workshop on scenarios for the LHC luminosity upgrade, LHC-LUMI-05, Arcidosso Italy, 31 August-3 September 2005," CARE-HHH-ADP Workshop on Scenarios For the LHC Luminosity Upgrade 31 Aug - 3 Sep 2005, Arcidosso, Italy.
  - [10] CMS Collaboration, "The CMS Physics Technical Design Report, Volume 1," *CERN/LHCC 2006-001* (2006). CMS TDR 8.1.
  - [11] F. Gianotti, M. Mangano, T. Virdee, et al., "Physics Potential and Experimental Challenges of the LHC Luminosity Upgrade," *Eur. Phys. J.* **C39** (2004) 293–333. [doi:10.1140/epjc/s2004-02061-6](https://doi.org/10.1140/epjc/s2004-02061-6).



- [12] M. Battaglia et al., "Proposed post-LEP benchmarks for supersymmetry," *Eur. Phys. J. C* **22** (2001) 535–561, [arXiv:hep-ph/0106204](https://arxiv.org/abs/hep-ph/0106204).
- [13] B. Gjelsten, D. Miller, and P. Osland *JHEP* **06** (2005) 015.
- [14] B. Gjelsten, D. Miller, and P. Osland *JHEP* **12** (2003) 003.
- [15] **LHC/LC Study Group** Collaboration, A. Barr, "Determining the spin of supersymmetric particles at the LHC using lepton charge asymmetry," [arXiv:hep-ph/0405052](https://arxiv.org/abs/hep-ph/0405052).
- [16] **CMS** Collaboration, G. Bayatian et al., "CMS Physics TDR Volume 2," *CERN/LHCC 2006-021* (2006).
- [17] R. Cousins, J. Mumford, and V. Valuev, "Measurement of Forward-Backward Asymmetry of Simulated and Reconstructed  $Z' \rightarrow \mu^+ \mu^-$  Events in CMS," *CMS Note 2005-022* (2005).
- [18] R. Cousins, J. Mumford, J. Tucker, and V. Valuev, "Spin discrimination of new heavy resonances at the LHC," *JHEP* **11** (2005) 046.  
[doi:10.1088/1126-6708/2005/11/046](https://doi.org/10.1088/1126-6708/2005/11/046).
- [19] "Fourth CMS Workshop on Detectors and Electronics for the SLHC." Located at <http://indico.cern.ch/conferenceDisplay.py?confId=a06865>.
- [20] C. Roland, "Track reconstruction in heavy ion events using the CMS tracker," CERN-CMS-NOTE-2006-031.
- [21] **CERN RD50** Collaboration, A. Macchiolo, "The CERN RD50 Collaboration: Development of radiation-hard semiconductor detectors for super-LHC," *AIP Conf. Proc.* **794** (2005) 302–306.
- [22] M. Weber, G. Villani, and M. Lammentausta, "Serial powering for silicon strip detectors at SLHC,". Prepared for 11th Workshop on Electronics for LHC and Future Experiments (LECC 2005), Heidelberg, Germany, 12-16 September 2005.
- [23] R. Ely and M. Garcia-Sciveres, "DC to DC Power Conversion,". Prepared for 12th Workshop on Electronics for LHC and Future Experiments (LECC 2006), Valencia, Spain, September 2006.
- [24] F. Palla, "Proposal for a First Level Trigger using pixel detector for CMS at Super LHC," in *Proceedings of LECC 2006 Valencia*. 2006.
- [25] J. Jones, G. Hall, C. Foudas, and A. Rose, "A pixel detector for level-1 triggering at SLHC," [arXiv:physics/0510228](https://arxiv.org/abs/physics/0510228).
- [26] CMS Collaboration, "The TriDAS Project Technical Design Report, Volume 2: Data Acquisition and High-Level Trigger," *CERN/LHCC 2002-26* (2002). CMS TDR 6.2.
- [27] B. G. Taylor, "Timing distribution at the LHC,". Prepared for 8th Workshop on Electronics for LHC Experiments, Colmar, France, 9-13 Sep 2002.
- [28] "CMS SLHC Upgrade Steering Group Web Site." Located at [http://cmsdoc.cern.ch/cms/electronics/html/elec\\_web/common/slhc.html](http://cmsdoc.cern.ch/cms/electronics/html/elec_web/common/slhc.html).