

# DESIGN AND COMMISSIONING OF FERMILAB'S VERTICAL TEST STAND FOR ILC SRF CAVITIES\*

Joseph P. Ozelis#, Ruben Carcagno, Camille M. Ginsburg, Yuenian Huang, Barry Norris, Thomas Peterson, Valeri Poloubotko, Roger Rabehl, Igor Rakhno, Clark Reid, Dmitri A. Sergatskov, Cosmore Sylvester, Mayling Wong, Chuck Worel, Fermilab, Batavia, IL. 60510, USA

## Abstract

As part of its ILC program, Fermilab is developing a facility for vertical testing of SRF cavities. It operates at a nominal temperature of 2K, using a cryoplant that can supply LHe in excess of 20g/sec and provide bath pumping capacity of 125W at 2K. The below-grade cryostat consists of a vacuum vessel and LHe vessel, equipped with magnetic shielding to reduce the ambient magnetic field to <10mG. Internal fixed and external movable radiation shielding ensures that exposure to personnel is minimized. The facility features an integrated personnel safety system consisting of RF switches, interlocks, and area radiation monitors.

## INTRODUCTION & FACILITY REQUIREMENTS

The Vertical Test Stand (VTS) at Fermilab is designed to test superconducting RF (SRF) cavities at a nominal frequency of 1.3GHz in a 2K LHe bath, and will support up to 48 cavity tests per year, while operating in single-cavity test mode. The VTS has been designed to accommodate two 9-cell cavities as a means of increasing throughput to 80 cavity tests/year. Test turnaround time is minimized by utilizing the full capacity of the existing cryoplant (shared with the SC magnet test facility), which can supply LHe at a rate exceeding 20 g/sec. The cryoplant also includes a pair of vacuum pumps that provide 125W (6 g/sec) of combined cooling power at 2 Kelvin, with a minimum temperature capability as low as 1.6K[1]. A system of radiation shielding was needed to ensure that exposure levels are maintained below prescribed levels.

## FACILITY DESIGN FEATURES & DETAILS

### Civil Construction & Layout

The VTS cryostat (Fig. 1) is installed below grade into a 20' deep 4.2' diameter cylindrical shaft excavated in the floor. The top plate of the cryostat is 32" below floor level, approximately centered in a rectangular pit 7.3' x 8.3' in dimension. A labyrinthine trench 2' wide and 2' deep, covered with steel plates, provides a means for instrumentation and cryogenic service access to the cryostat when the radiation shielding lid is in place. The

\*Work supported by U.S. Department of Energy under contract DE-AC02-76CH03000

#ozelis@fnal.gov

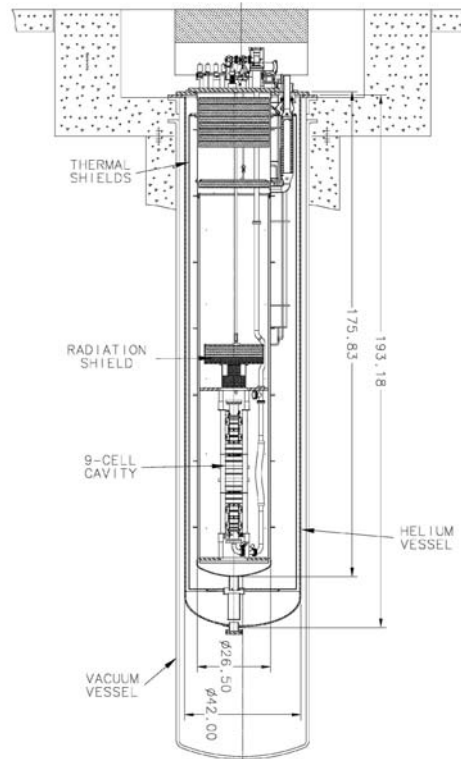

Figure 1. Layout of VTS cryostat & components

pit and trench are lined with 2' of concrete, while the walls of the cylindrical hole are lined with 1' of concrete, providing additional radiation shielding.

### Cryostat

The VTS cryostat consists of an ASME code-stamped helium vessel (rated to 80psia) within a vacuum vessel, both made of 304 stainless steel. The vacuum vessel has a 41.25" inner diameter, 0.375" wall thickness and is 16' long. The helium vessel has a 26.32" inner diameter, 0.094" wall thickness, and 14.6' length, holding approximately 1500 L of LHe. Two-phase helium is supplied to the cryostat through a phase separator, and enters the helium vessel either through a top-fill or bottom-fill port. A heater located at the bottom of the helium vessel provides up to 250W to expedite LHe boil-off and warm-up of the Dewar after cavity testing is complete.

The cryostat is equipped with redundant ASME-compliant pressure relief systems for the helium circuit, which is comprised of a primary device that includes a 1.5" diameter burst disk combined with a re-closable

safety relief valve, at a set pressure of 55-psig. A similar device configured in parallel, having a set pressure of 65-psig, acts as a secondary relief. The relief system is sized assuming complete helium vaporization due to a leak in the insulating vacuum, resulting in a heat flux of 0.6 W/cm<sup>2</sup> on the helium vessel wall. For operational pressure relief, a Fermilab-built Kautzky relief valve with a set pressure of 15-psig is installed in parallel with these relief systems. All three devices are designed to avoid sub-atmospheric leakage into the helium circuits.

To reduce the cryostat's overall static heat load at 2K, an 80K thermal shield is mounted between the helium and vacuum vessel walls, and a 5K annular thermal intercept is welded to the exterior of the helium vessel.

### Cryogenic System and Controls

Cryogenic process controls for the VTS are based on controls at the superconducting magnet test facility cryoplant which is shared by the VTS [2]. Two layers of control are implemented – a PLC at the field level and a commercial SCADA/HMI for operator interfacing. A Siemens 545 Simatic PLC unit connects to approximately 70 sensors for monitoring and controlling all stages of the cryogenic process. Sensotec and MKS transducers are used to monitor pressure, LHe level monitoring is performed by American Magnetics Model 135-2K instruments, while Lakeshore Cernox CX-1030-SD devices allow bath temperatures to be measured down to the 1.6 K design point. Control loops are established for level and pressure control inside of the PLC logic.

GE Fanuc's Intellution iFix 3.5 SCADA system, already in use for cryogenic plant operations, has been extended for all cryogenic process data logging and control of the VTS. Cryogenic plant operators can control the cryogenic plant and any test stand, including VTS, from one central control room. The overall control strategy for VTS is to maximize automation and minimize operator intervention. Each cavity tested in the VTS will require a set of cryogenic operations – including pump and backfill, contamination monitoring, 4.5 K fill, 2 K pump down, and warm up – which will be automated as batch processes. Once their systematic behavior is verified and proven to be repeatable, this strategy will be fully implemented.

### Magnetic Shielding

To avoid trapping magnetic flux thereby degrading the cavity quality factor, the cavity must be shielded from magnetic fields during cool down. This is accomplished using a two-layer cylindrical magnetic shielding design, expected to yield a remnant field of < 10mG in the cavity region. The design incorporates a room temperature outer shield outside the vacuum vessel, and an inner shield inside the helium vessel. The outer shield is made of 0.040" thick Amumetal®, with a length of 166" and an inner diameter of 42.13". The inner shield has one perforated end cap at the bottom (for LHe flow), and is made of 0.040" thick Cryoperm 10®, with a length of 133" and an inner diameter of 25". It is attached to the

outer surface of an aluminum cylinder for support and protection, and will be permanently installed.

The magnetic field inside the cryostat has been measured as a function of depth, and at various azimuthal positions. Measurements were performed in the empty pit and in the helium vessel of the cryostat with and without the outer shielding in place. The measurement in the empty pit was consistent with the Earth's magnetic field. The measurement with the cryostat and outer shield in place shows that the field in the area of interest is less than 50mG. The measurement of the magnetic field with both shields in place will be performed soon.

### Test Stand Insert

The test stand insert supports the cavity in the LHe bath. It consists of a 1.25" thick stainless steel top plate with several penetrations for RF and instrumentation cable feedthroughs. A set of thermal radiation baffles and a 5K cold Helium intercept plate are suspended from the top plate using threaded rods, which also support the internal radiation shielding from which the cavity support cage is suspended. A set of G-10 plates located above and below the cavity support cage serve as a standoff for the insert, guiding the insert into the Dewar and protecting the cavity from contact with the Dewar walls. The complete insert w/ cavity is shown schematically in Fig. 2.

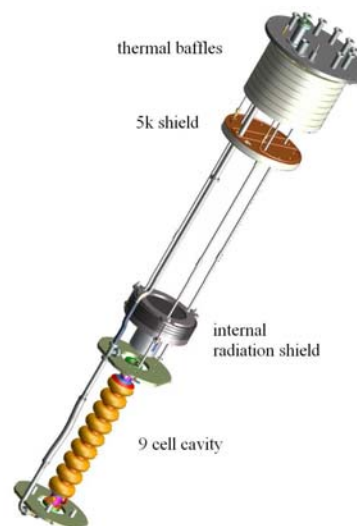

Figure 2. Test stand insert w/ thermal baffles/shields, radiation shielding, and 9-cell cavity.

### Internal and External Radiation Shielding

In order to prevent radiation exposure to personnel a system of radiation shielding has been designed based on modeling using MARS15 [3]. The exposure reduction is achieved using both internal radiation shielding (mounted on each test stand insert), and an external shield placed over the Dewar top plate during cavity testing.

The internal shielding consists of a pair of 4" thick lead disks (one 8" diameter, another 6" diameter) mounted just above the cavity, a 2" thick 21" diameter steel disk mounted above the lead disk, and a 4" thick 21" diameter

disk of borated polyethylene above the steel disk.

The external shielding comprises a movable lid and chain drive system (Fig. 3). The lid moves on rails mounted to the concrete floor of the building. The rails can be extended to allow this shield to service future additional in-ground Dewars. The lid provides radiation absorption by utilizing a 6" thick steel base and 18" high concrete blocks. The base has cutouts to accept Hillman® heavy-duty rollers, which provide a low friction system for movement of this 31 ton assembly. The chain pull system consists of a chain drive motor and gearbox, and two chain channels with idler sprockets that guide the floor-mounted chains over the radiation lid as it moves. A cable gantry and wall-mounted track provides the means for supplying power to the shielding block mounted motor controller as it moves.

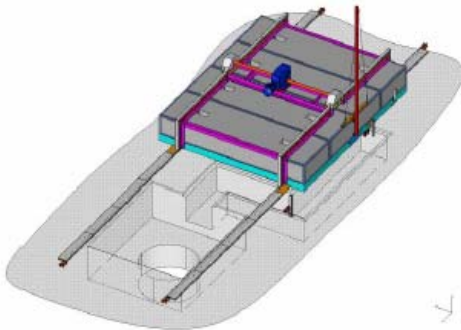

Figure 3. The external radiation shield and movement mechanism

### *RF & DAQ System*

The RF system employs the classic combination of oscillator, phase detector/mixer, and loop amplifier to detect the resonant cavity frequency and adjust the RF source frequency to lock onto the cavity. The design, described in greater detail elsewhere [4], is based upon the system employed at JLab for production cavity tests, and makes extensive use of commercial components. Control software is written in the LabView environment, and provides near fully-automated operation.

### *Interlocks and Safety Systems*

A system of interlocks is used to prevent personnel exposure to ionizing radiation. Magnetic and mechanical switches are used to indicate when the radiation shielding lid is in position over the Dewar pit, which is required for the enable for high power (HP) RF operation to be granted. A set of area radiation monitors outside of the shielding lid are used in conjunction with the lid position switches. In the event that any of these monitors detect the presence of radiation above background levels, the HP RF permit is disabled by switching off the output of the LLRF system, disabling the HP amplifier input, and disabling AC power to the HP amplifier. The interlock system requires the logical AND of the enable signals from both lid switches and the area radiation monitors.

## **INITIAL CRYOGENIC PERFORMANCE**

Initial cryogenic commissioning of the VTS cryostat was performed recently. After an initial cooldown of about an hour, LHe began to collect in the cryostat at a rate of about 500 L/hr (16.7 g/sec), consistent with expectations. Static heat load measurements yielded 4.3W at 4K, agreeing well with the calculated value of 4.6W.

The LHe bath was subsequently pumped down to 2K (23 Torr) over a period of just over 3hrs, and with a loss of about 37% of LHe volume. This pumpdown speed compares very favorably with other similar facilities. The lowest bath temperature reached was 1.55K (corresponding to a Dewar pressure of 2.3 Torr).

Heater-assisted boil off of the LHe inventory was measured and compared with value expected based on the Dewar heater setting. The observed rate of 203W compares well with the sum of the applied heater power (195W) and static heat load (~5W).

## **STATUS & FUTURE PLANS**

Initial cryogenic commissioning has been successfully performed in the VTS. A low-power test of a single cell cavity will be performed soon. The external radiation shielding assembly is in progress and should be completed mid-summer 2007. An integrated system commissioning, consisting of a full high power (500W) test of a 9-cell ILC cavity will follow.

To meet expanding cavity testing requirements the VTS facility will be upgraded to increase throughput and improve reliability and operability. This entails the installation of 2 additional VTS stations, a dedicated 13 g/s sub-atmospheric Helium pumping system, the addition of a 30g/s Helium purifier, and additional Helium gas storage. These upgrades are planned to begin in FY08, contingent upon available funding.

## **ACKNOWLEDGMENTS**

The authors are indebted to the technical staff of the Fermilab TD/ Test & Instrumentation department for their diligent efforts in bringing the VTS to reality.

## **REFERENCES**

- [1] Y. Huang and J. P. Ozelis, "Performance Analysis and Requirements of the ILC Vertical Cavity Test Stand Cryogenic System at IB1", Fermilab note TD-06-012
- [2] R. Carcagno and R. Rabehl, "Controls Upgrade of the Fermilab Magnet Test Facility 1500 W Helium Refrigerator," *Advances in Cryogenic Engineering*, vol. 45, pp. 1795–1802, Plenum Press, New York, (2000)
- [3] I. Rakhno, "Radiation Shielding Issues for Superconducting RF Cavity Test Facility at Fermilab", Fermilab note TM-2367-AD
- [4] C. Grenoble, R. Nehring, J. P. Ozelis, T. J. Powers, "RF and Data Acquisition Systems for Fermilab's ILC SRF Cavity Vertical Test Stand", paper WEPMN107, this conference.