

STATUS OF THE FNAL TEVATRON PROGRAM

A. V. Tollestrup

Fermi National Accelerator Laboratory*

I. The Tevatron

The physics program at Fermilab is built around the Tevatron, a 1,000 GeV accelerator constructed from superconducting magnets. The recent successful commissioning of this ring has been a milestone in the development of accelerators. A successful physics run at 400 GeV was completed between October 1983 and January 1984, and recently the machine has started running for the fixed target physics program at 800 GeV. A log of the important dates in this commissioning is shown in Table I.

An extensive R&D program for superconducting magnets was carried out at Fermilab in the five years prior to the authorization. During the four years between authorization and the time the last magnet was installed, 774 dipoles and 210 superconducting quads were constructed as well as approximately 1,000 superconducting correction coils. The major problem and accomplishment during the magnet construction was to achieve a high degree of quality control for the coil fabrication as well as for the fabrication of the cryogenic system. There are about 2,600 vacuum connections and almost 4,000 refrigerator connections in the system. These connections had to be made under field conditions and with a high degree of reliability.

*Operated by Universities Research Association under Contract with the United States Department of Energy

Table I

Tevatron Status:

Machine

July 1979	Authorize
March 1983	Last magnet installed Peak production 10/week, 776 D, 240 Q
April 1983	Finish leak check connection
May 1983	Cool down/power tests
June 1983	First turn/multiple turns
July 1983	512 GeV
August 1983	512 extracted 512 stored 700 accel.
September 1983	Beam to proton area
October 1983	400 GeV physics
November 1983	7 beams to experimental areas
February 1984	800 GeV tests
March 1984	800 GeV physics
April 1984	Low β test B0 Fast extraction
May 1984	At B0 β^* = 2 M

The Tevatron consists of 774 dipoles and 216 quadrupoles which are all connected in series. The beam tube aperture is 3 in. and is held at liquid helium temperature. A half-cell consists of four dipoles and one quadrupole. Each quadrupole cryostat also houses the small correction coils that are dispersed around the lattice. These coils have been wound in the

form of dipoles, quadrupoles, sextupoles, and octapoles, and the leads are brought out locally. In addition, beam position electrodes are also located in the quad cryostats. The safety leads for magnet quench protection and the He feed and power feed are located in these cryostats.

The beam is injected into the Tevatron from the Main Ring at an energy of 150 GeV. The quench protection system is under the control of 25 microprocessors and is an active one, i.e., if a quench is detected, the appropriate sets of magnets are shorted and heaters are fired within the coil structure to raise the temperature to drive them normal. The energy from the field is absorbed by the heat capacity of the magnet winding.

As can be seen from the above log of dates, the machine first ran at 400 GeV. During this time, much experience in beam extraction and machine operation was obtained. In February, tests of the machine at 800 GeV were made, and the 800 GeV physics program started in March. In the meantime, during the machine study periods, low beta tests at B0 have been made, and a β^* of 1 meter has been obtained. During studies the beam has also been stored at 800 GeV.

At present the acceleration cycle is 65 seconds, and a 20 second spill has been obtained which represents a 30 percent duty factor. The peak beam in the machine has been 10^{13} protons. Fast extraction is more difficult for a superconducting accelerator as a large amount of energy can be dumped into the coils in a very short period of time if there is appreciable beam

100s. At present at 800 GeV, fast extraction at the level of 2×10^{12} protons per pulse has been achieved.

The accelerator is scheduled to shut down in the summer of 1984. During this period an 8 GeV extraction line from the booster to the accumulator will be installed. This will allow \bar{p} source studies to take place independently of the Main Ring or the Tevatron. In addition, an overpass in the Main Ring will be installed at D0. This overpass is smaller than the one that is to be installed at B0 in 1985, and its commissioning will give confidence and experience for solving the more difficult problem at B0. Also during this coming summer, the extraction system for 120 GeV protons for \bar{p} production will be installed as well as the 8 GeV \bar{p} injection line into the Main Ring and the 150 GeV \bar{p} transfer line between the Main Ring and Tevatron.

Since the Tevatron represents the first superconducting accelerator ring, it is interesting to look at the statistics of its performance. At present, it is rather early to draw any firm conclusions since the running time has been rather short. However, the information that is presently available is shown in the following figures. Fig. 1 shows the percentage of scheduled HEP time that the machine ran during the 400 GeV running and during the 800 GeV running up through May. The graphs in Fig. 2 and Fig. 3 show the percentage of scheduled downtime accounted for by the various accelerator subsystems. It is seen that the Tevatron is still the least reliable component of the accelerator. A breakdown of the lost time due to the Tevatron

components during the 400 GeV run is shown in Fig. 4. It is seen that the refrigerator system, the power supplies, the quench protection system, and the controls account for the major portion of the downtime. It is expected that the reliability will improve considerably as more experience is obtained with the machine.

II. TeV II: The Fixed Target Physics Program

The Tevatron is now operating at 800 GeV with an extracted beam whose duty cycles are about 30 percent. The increased flux in secondary beams due to the higher energy of the incident protons plus the larger duty cycle are making a significant impact on the experimental program.

At present there are over 30 approved fixed target experiments which include a beam dump prompt neutrino experiment, polarized proton experiments, muon scattering experiments, and photon experiments. A tagged wide band photon beam and a new muon beam are under construction, and other new beams are under design.

Fig. 5 shows the layout of all the beams either existing, planned, or under construction. And Table II lists the presently approved experiments. It is apparent from this list that the experiments span the whole field of high energy physics. This encompasses beauty and charm production, QCD jet physics, and the whole gambit of manifestations of the weak interactions. In addition, heavy use is being made of the test beam by CDF, D0, and other groups developing new detector equipment.

III. TeV I

The colliding beam program at Fermilab will study collisions between protons and antiprotons in the Tevatron at a center of mass energy of 2 TeV. An antiproton source is under construction, and an assembly hall and collision hall have been completed at straight section B0 to house the CDF detector. A second collision region at straight section D0 is being planned. Smaller experiments have been proposed for C0, E0, and F0. The experimental program is expected to commence in early 1986.

The Source encompasses the principles used by the AA at CERN but modified and improved in the Fermilab design to greatly enhance the flux. Table III gives the design parameters, and Fig. 6 shows the layout.

Table III

Luminosity	$10^{30} \text{ cm}^2 \text{ sec}^{-1}$
Total No. \bar{p} needed	2×10^{11}
Accumulation rate	$10^{11} \bar{p}/\text{hour}$
\bar{p} production by 120 GeV protons	$8 \times 10^7 / 2 \text{ sec cycle}$
Transverse phase space e_x, e_y	$20 \pi \text{ mm mr}$
$\delta p/p$ at 8 GeV	3 percent
\bar{p} density in core	$10^5 / \text{ev}$
e_x, e_y	$2 \pi \text{ mm mr}$

The major points to notice are that a luminosity of 10^{30} is planned and that the collection time for the antiprotons is initially four hours with a rejuvenation period of only two

hours. In order to achieve this high collection rate for \bar{p} 's, it has been necessary to construct two rings; (1) a debuncher, and (2) an accumulator ring. A short description of the operation of these rings follows:

Protons at 120 GeV in the Main Ring are prepared by RF manipulation so that the bunches have a time spread of less than 1 nanosecond. These tightly bunched protons are extracted in one turn and impinge upon the production target after being focused to a spot with a σ of about .4 mm. Every 2 seconds 2×10^{11} antiprotons are collected with the help of a lithium lens and transported to the debuncher ring. In the debuncher an RF bucket rotation by 90° is performed which decreases the momentum spread of the beam to .2 percent and lengthens the time spread proportionately. The beam then undergoes transverse stochastic cooling to reduce its emittance from 20π to 7π . This process takes two seconds and is accomplished between the Main Ring cycles for \bar{p} production.

The \bar{p} 's are then extracted from the debuncher and injected into the accumulator where they undergo momentum stacking with simultaneous transverse cooling. Finally, a core cooling system takes over which operates at 2 to 4 GHz and achieves a density of greater than $10^5 \bar{p}$ per electron volt. At this time $2 \times 10^{11} \bar{p}$ can be removed from the core and injected into the Tevatron. The acceleration of these antiprotons with three similarly prepared bunches of protons to 1 TeV leads to a luminosity of 10^{30} . The Source can replenish the stack every two hours. This is a very

brief description of the Source, and more complete details can be found in the Fermilab Design Report.

As of May 1984 the construction of the Source is well underway. The ring enclosure is essentially complete, the target hall is under construction, and all of the quadrupoles for the debuncher have been constructed. Components of the stochastic cooling system are being delivered and are meeting the specifications desired. The magnet system for the two rings should be complete before the end of 1984, and preliminary injection studies are planned for early 1985. Preliminary tests of $\bar{p}p$ collisions will take place in mid 1985. At this point the machine will be shut down for the construction of the collision and assembly halls at D0 and for the overpass of the Main Ring at 60. It will be possible to continue development and study of the debuncher and accumulator rings by using protons from the booster during this construction period.

Civil construction on the overpass and D0 will be completed in 1986, and the colliding beam program will then commence.

IV. Colliding Beam Physics Program

A summary of the experiments proposed for collider operation is shown in Table IV.

Table IV

<u>Region</u>	<u>Experiment</u>
B0	CDF. Magnet 1.5 T; EM, had. calor; μ toroids
C0	E-735. Quark gluon plasma
D0	D0 detector. Liq. ar. uranium cal; mag. iron μ
E0	E-710. $\bar{p}p$ elastic and total cross section
F0	E-713. Highly ionizing particles E-723. Gravitational effects

CDF is a 4π calorimetric detector with a 1.5 Tesla solenoidal tracking field around the collision region. D0 is a 4π uranium liquid argon calorimetric detector with muon momentum measurement in magnetized iron that surrounds the calorimeter. The experiment at D0, E-710, plans to measure the elastic scattering and total cross sections at center-of-mass energies between 300 and 2,000 GeV. Roman Pots will be used to measure the elastically scattered particles. At F0, E-713 will use plastic track detectors to search for highly ionizing particles with a charge of greater than 20 e. E-735 has been proposed for the C0 collision region and is geared to look for evidence of quark plasma effects in high energy collisions. Experiment E-723 plans to search for gravitational effects of highly relativistic particles.

Fig. 7 shows in perspective the CDF detector at B0. The hadron and electromagnetic calorimetry for this detector are arranged in the form of towers that divide phase space up into units of .1 in rapidity and 15° in phi for polar angles between

2° and 178° . In all cases this spacial resolution is sufficient so that several towers span a typical QCD jet. Toroids measure muons between 2° and 15° , and a tracking system at the back of the hadron calorimeter measures them between 45° and 135° . The central region has a magnetic field of 1.5 T generated by superconducting solenoid which is 3 meters in diameter and 5 meters long and where tracking is done by means of a drift chamber. The vertex region is covered by a vertex TPC which will be supplemented later by a silicon strip detector.

The status of the CDF detector is as follows: About 1/4 of the electromagnetic and hadron calorimeter modules for the central region have been constructed and calibrated. The magnet yoke is under assembly at Fermilab, and the superconducting coil, constructed at Hitachi, has undergone preliminary tests at 60 percent of its final current. The calorimetry for the end plug is about one-fourth complete, and preliminary calibration tests are being run on these modules. Two test beams at Fermilab are being used to calibrate and study these calorimeters. The design for the central tracking chamber is now complete, and the end plates for these chamber have been ordered. It is expected that for the \bar{p} tests scheduled for June 1985, that we will be able to test all components of the detector except for the central tracking chamber which cannot then be inserted due to interference with the Main Ring beam pipe. The complete detector and its data acquisition system will be ready for preliminary tests in 1986 and for a major physics run in the latter half of that year.

Fig. 8 shows a perspective drawing of the D0 detector. It will consist of a large liquid argon uranium calorimeter covering essentially 4π . The inside volume of the calorimeter contains a central tracking chamber and a transition radiation electron identifier. The outside of the calorimeter is surrounded by magnetized iron and a muon detection system. The building that houses this detector will be completed in 1986, and the detector itself should be operational in 1988.

V. Summary

The Tevatron is providing a learning ground for the application of superconductivity to high energy physics. It has necessitated the wide spread dissemination of cryogenic knowledge to the operations personnel, and they are developing techniques for running a large scale superconducting accelerator. The preliminary results with the stability and ease of operation of the machine are very encouraging. By 1988 the Tevatron will be exploiting an extended fixed target program as well as a colliding beam program at a center-of-mass energy of 2 TeV. It is supplying the necessary knowledge to place the next large accelerator on a firm foundation.

Table II

LIST OF CURRENTLY APPROVED FIXED TARGET EXPERIMENTS

E-400 (WISS):	CHARM PRODUCTION BY NEUTRONS
E-557 (MALAMUD):	HADRON JETS WITH THE MPS
E-605 (BROWN):	LEPTONS AND HADRONS NEAR THE KINEMATIC LIMITS
E-609 (SELOVE):	HIGH P_T HADRONIC JETS
E-615 (McDONALD):	FORWARD DI-MUON
*E-621 (THOMSON):	MEASUREMENT OF η_{+-0}
*E-632 (MORRISON):	15 FT. WITH Ne/H_2
*E-635 (MO):	AXION SEARCH
*E-636 (PLESS):	BEAM DUMP WITH 32" BUBBLE CHAMBER
*E-640 (LOKEN):	MUON SCATTERING WITH BERKELEY/PRINCETON MULTIMUON SPECTROMETER
*E-646 (BALTAY):	BEAM DUMP WITH 15 FT. BUBBLE CHAMBER
*E-649 (TAYLOR):	NEUTRINO EXPERIMENT WITH DICHROMATIC BEAM (LAB C)
*E-652 (SCIULLI):	NEUTRINO EXPERIMENT WITH DICHROMATIC BEAM (LAB E)
*E-653 (REAY):	HADRONIC PRODUCTION OF CHARM AND BEAUTY (HYBRID EMULSION SPECTROMETER)
*E-665 (KIRK):	OPEN GEOMETRY MUON SCATTERING EXPERIMENT
*E-672 (DZIERBA):	HIGH P_T JETS AND HIGH MASS DI-MUONS
*E-683 (CORMELL):	PHOTOPRODUCTION OF JETS
*E-687 (BUTLER):	PHOTOPRODUCTION OF CHARM AND BEAUTY
*E-690 (KNAPP):	CHARM AND BEAUTY PRODUCTION
*E-691 (HASH):	CHARM PRODUCTION BY TAGGED PHOTONS
*E-704 (YOKOSAWA):	POLARIZED BEAM EXPERIMENTS
*E-705 (COX):	CHARMONIUM AND DIRECT PHOTON
*E-706 (SLATTERY):	DIRECT PHOTON
*E-711 (LEVINHAL):	HADRONIC CONSTITUENT SCATTERING
E-715 (COOPER):	Σ β -DECAY
*T-721 (BUCHHOLZ):	CP VIOLATION
*E-731 (WINSTEIN):	PRECISION MEASUREMENT OF $ \eta_{00}/\eta_{+-} $
*E-733 (BROCK):	NEUTRINO EXPERIMENT WITH QUAD TRIPLET BEAM (LAB C)
*E-743 (REUCROFT):	CHARM PRODUCTION WITH LEBC
*E-744 (MERRITT):	NEUTRINO EXPERIMENT WITH QUAD TRIPLET BEAM (LAB E)
*E-745 (KITAGAKI):	NEUTRINO EXPERIMENT WITH HIGH RESOLUTION BUBBLE CHAMBER (ENGINEERING RUN FOR E-636)

*TEVATRON EXPERIMENTS

1/19/84

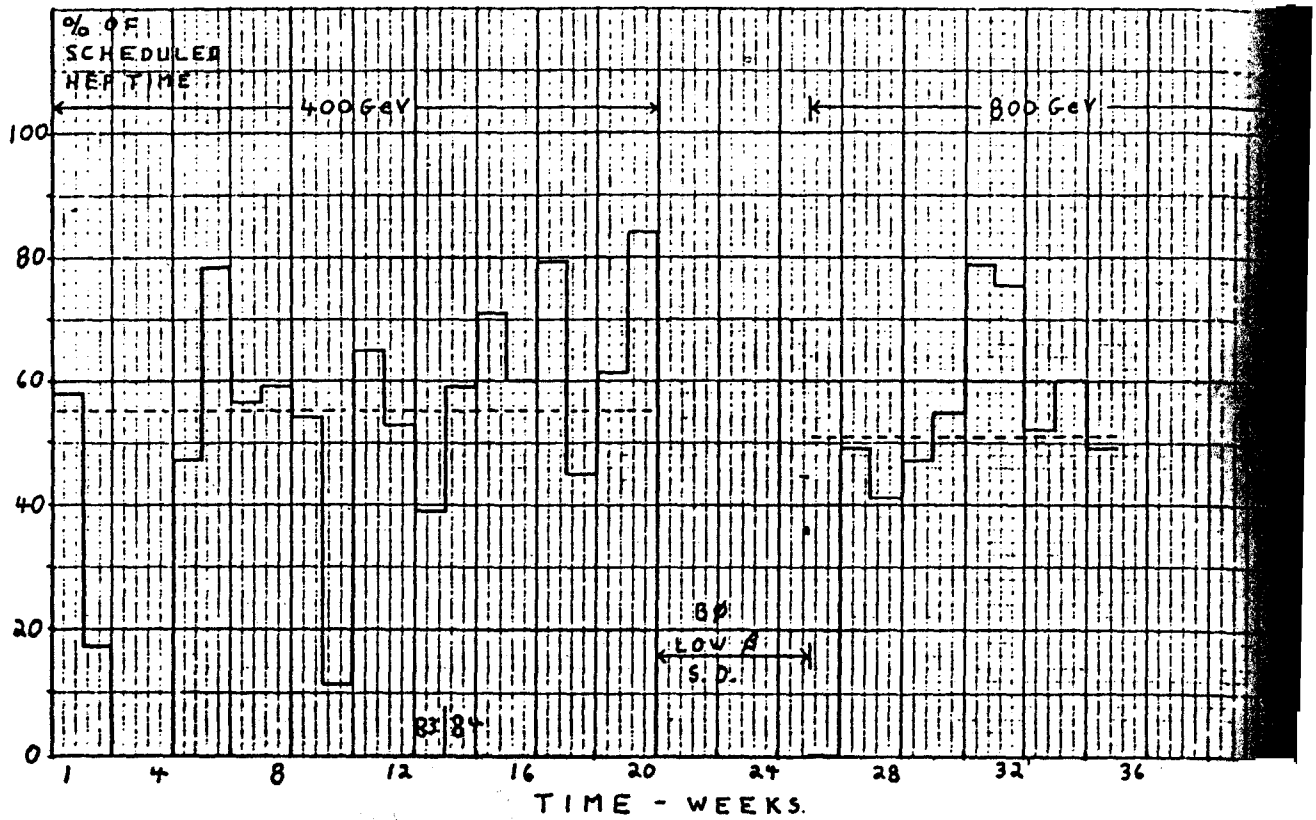

Fig. 1. Tevatron Performance

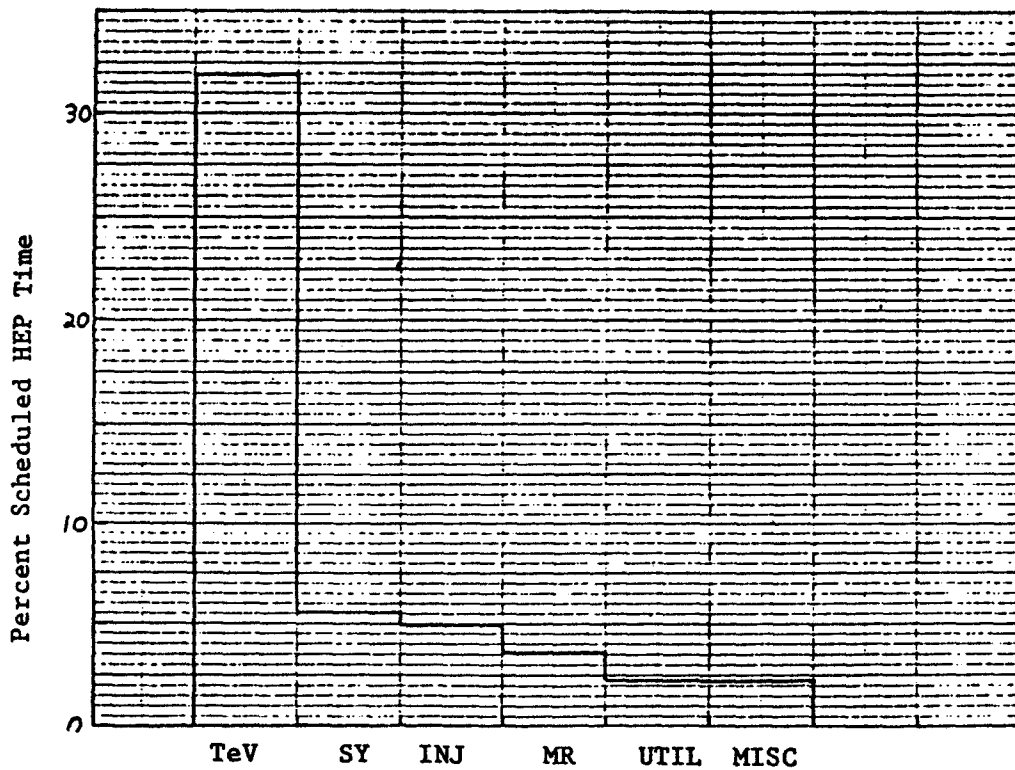
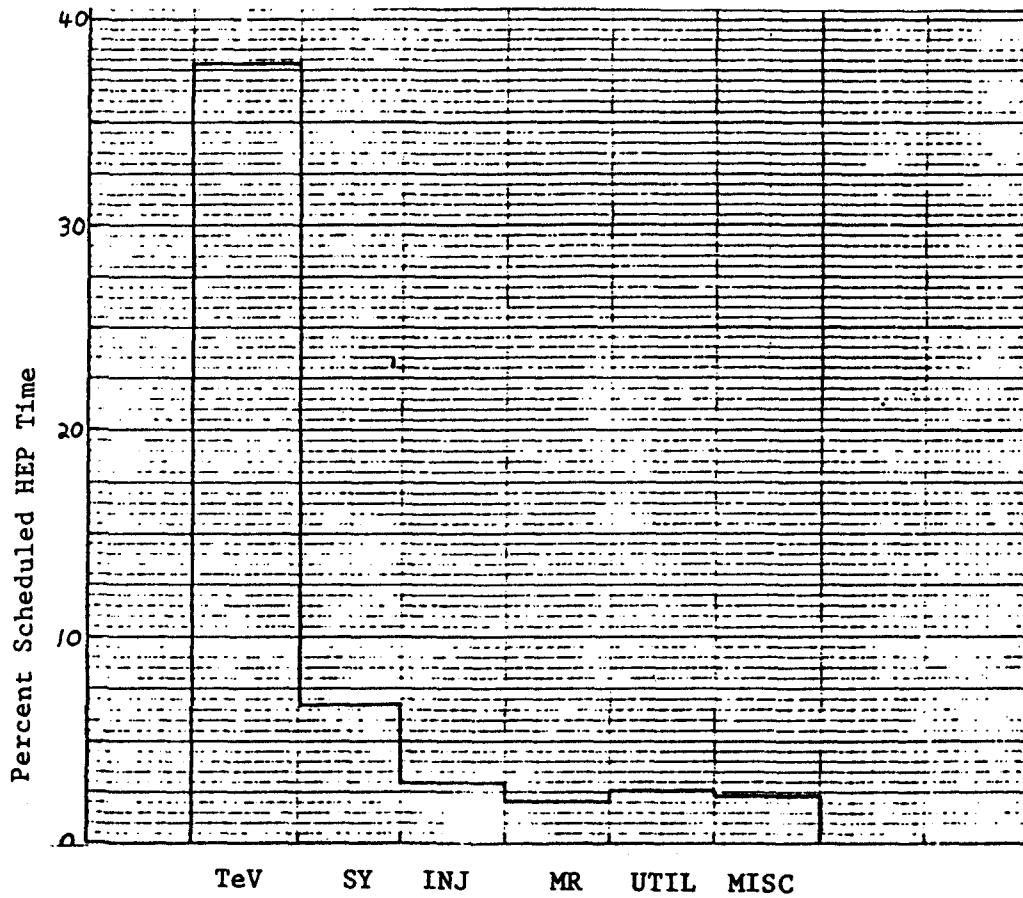

Fig. 2. Subsystem Downtime 400 GeV
See Fig. 3 for key



Key

- TeV Tevatron
- SY Switchyard
- INJ Injector
- MR Main Ring
- UTIL Utilities

Fig. 3. Subsystem Downtime 800 GeV
 The key is for this figure and Fig. 2

Tevatron Component Downtime 400 GeV

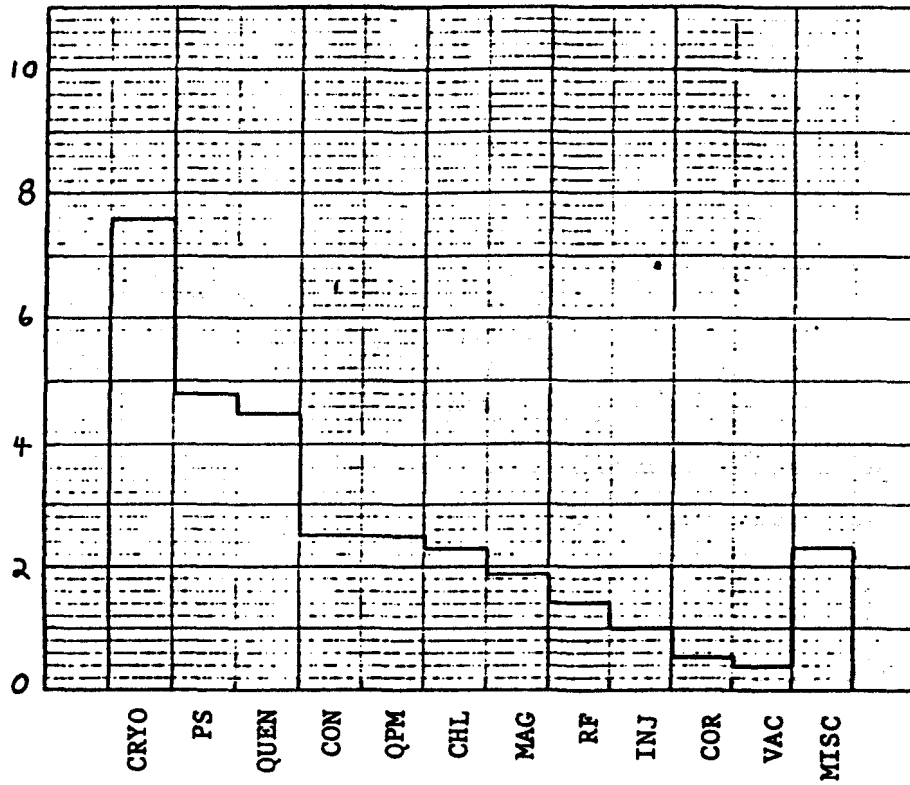

Key

- CRYO Cryogenics
- PS Power Supply
- QUEN Quenches
- CON Controls
- QPM Quench Protection System
- CHL Central He Liquefier
- RF Radio Frequency System
- INJ Injection System (150 GeV)
- COR Correction System
- VAC Vacuum System

Fig. 4

TEVATRON EXPERIMENTS

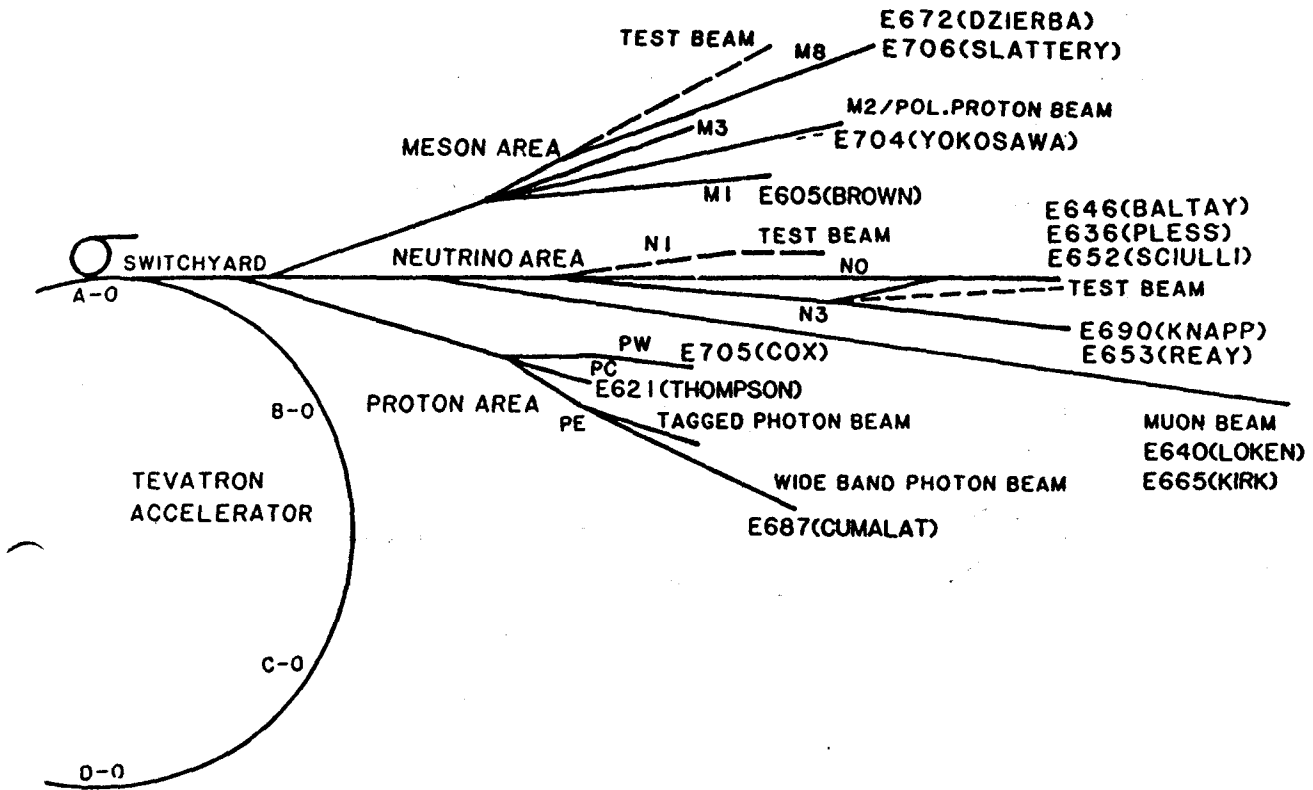
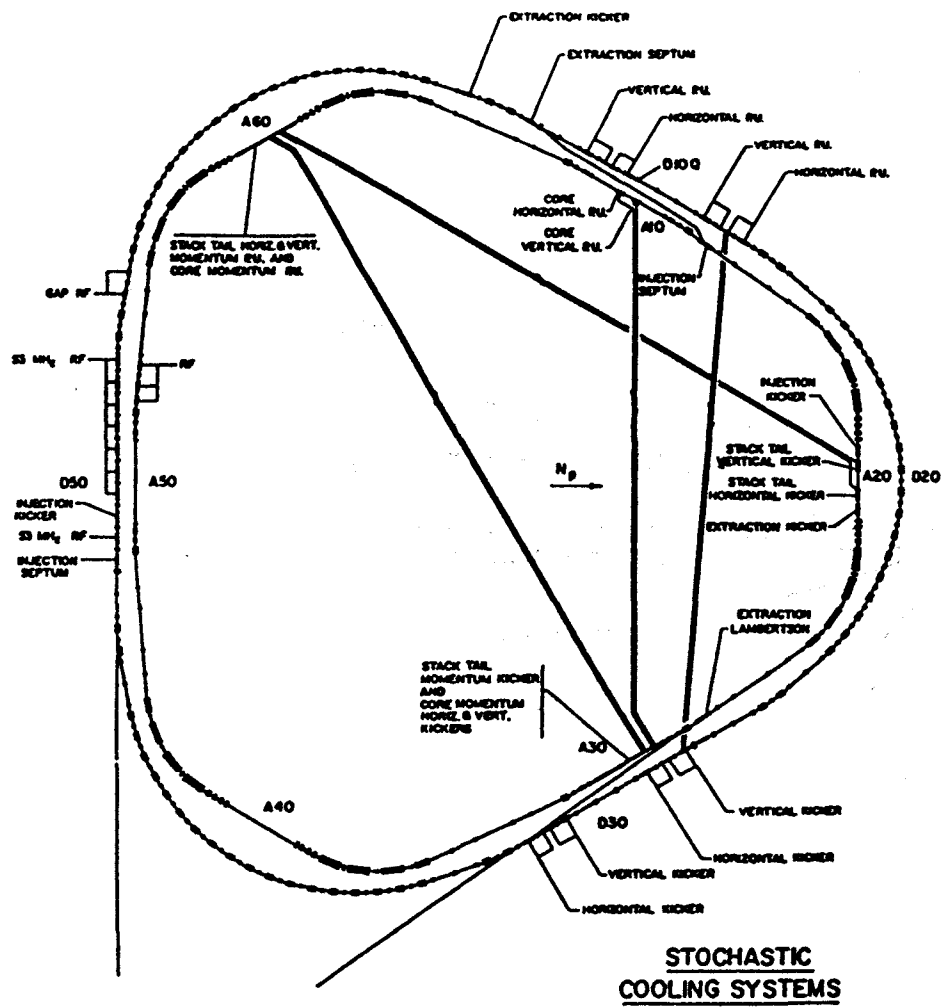

Fig. 5



**STOCHASTIC
COOLING SYSTEMS**

Fig. 6

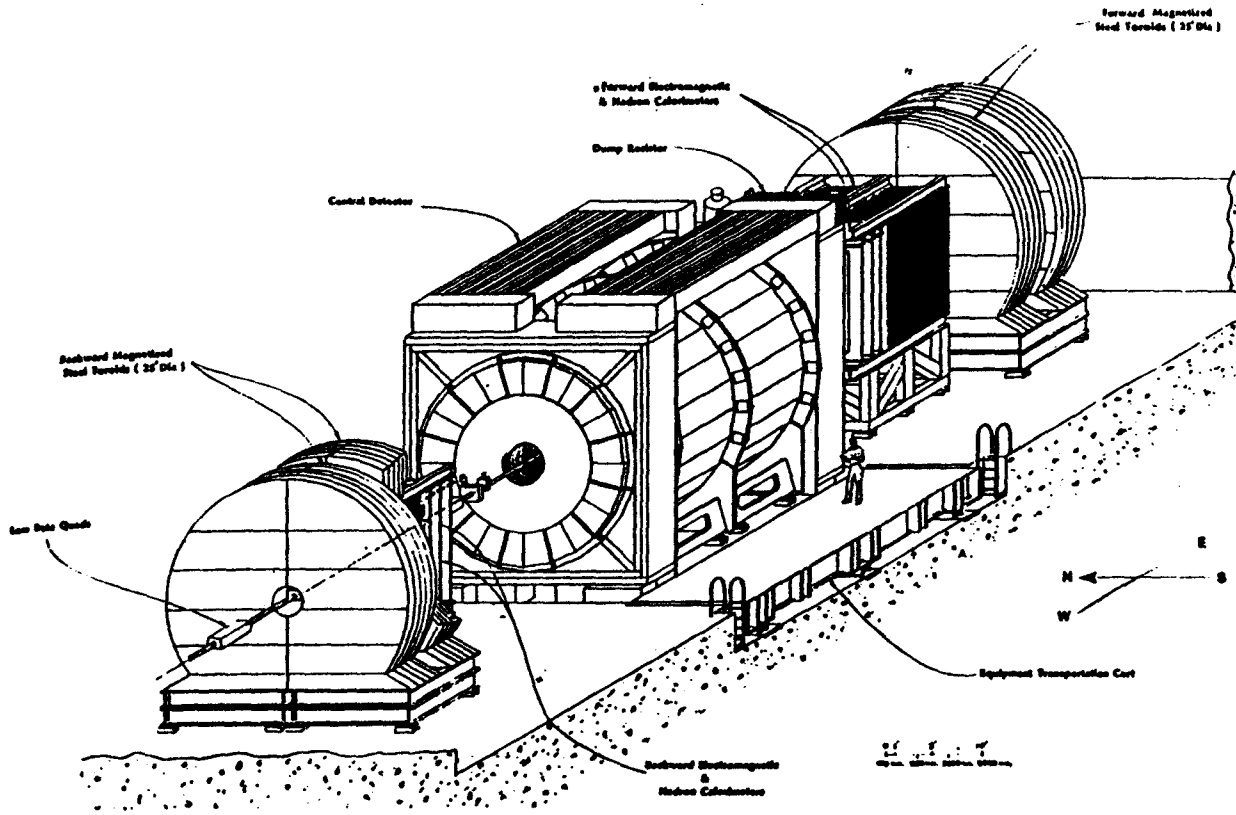

Fig. 7

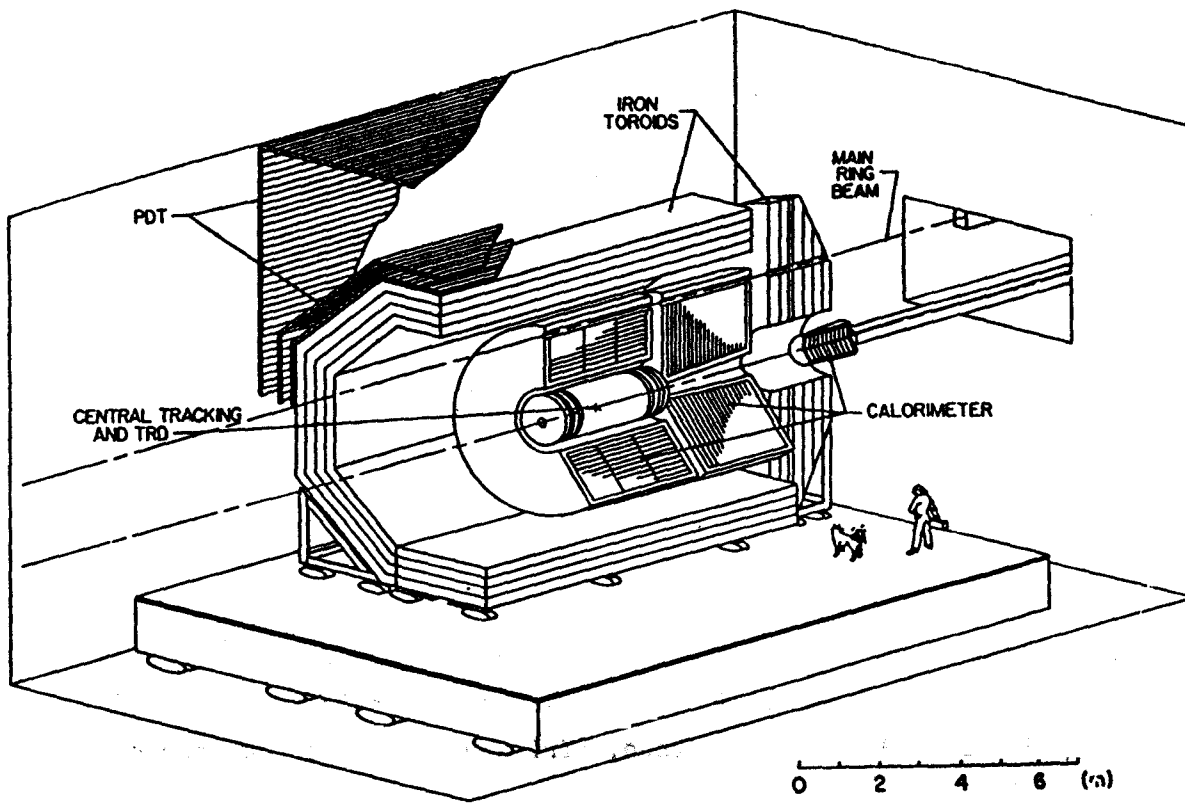

Fig. 8. Proposed D0 Detector