

Fermilab Research Program 2007

Workbook

March 2007

Roy Rubinstein

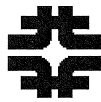

Fermi National Accelerator Laboratory
Batavia, Illinois

Operated by Universities Research Association, Inc.
Under Contract with the United States Department of Energy

Price \$5.00

INTRODUCTION

This Workbook, as for the past 32 Workbooks, gives summaries of the Laboratory's research activities, experiments and their publications, together with a statistical summary of the program.

As in the past, the experiment spokespersons provided considerable information for the Workbook, and their help is much appreciated. Jeff Appel gave encouragement and advice for the project, and Jud Parker kept up the databases on which much of the Workbook is based; significant thanks are due to both of them. The Workbook would, however, not be possible without the outstanding efforts of Jackie Coleman, who was the person that really produced it.

TABLE OF CONTENTS

	<u>Page</u>
I. Statistics on Fermilab Proposals	1
II. Accelerator Performance	5
III. Fermilab Beam Properties and Experiment Location	11
IV. Major Research Activities During 2006 and 2007	23
V. Fermilab Research Program	27
VI. Summaries of Approved Experiments	33
VII. Master List of Proposals	179

SECTION I. STATISTICS ON FERMILAB PROPOSALS

The status of Fermilab proposals is summarized in this Section of the Workbook. All proposals are classified into one of the following categories:

	<u>Categories</u>	<u>Definitions</u>
Approved Proposals	Completed	Approved proposals that have completed data-taking.
	Remaining	Approved proposals either running or waiting for data-taking.
	Inactive	Approved proposals which are now unlikely to ever be completed.
Pending Proposals	Unconsidered	Relatively new proposals awaiting consideration
	Deferred	Proposals for which consideration has been postponed for a specific reason
	"Not Approved"	Proposals for which a conventional decision cannot be made.
Obsolete Proposals	Rejected	Proposals rejected from further consideration
	Withdrawn/Inactive	Proposals that were not considered at the request of the spokesperson or that are no longer being considered for other reasons.

At the present time, 965 proposals have been received. Table 1 and Figure 1 show the number of proposals in each category each year since 1970.

TABLE 1. STATUS OF PROPOSALS AT FERMILAB

	Aug 1970	Jul 1971	Jul 1972	Jul 1973	Jul 1974	Jul 1975	Jul 1976	Jul 1977	Jul 1978	Jul 1979	Jul 1980	Jul 1981	Jul 1982	Jul 1983	Jul 1984	Jul 1985	Jul 1986	Jul 1987	Jul 1988	Jul 1989	Jul 1990	Jul 1991	Jul 1992	Jul 1993	Jul 1994	Jul 1995	Jul 1996	Jul 1997	Jul 1998	Jul 1999	Jul 2000	Jul 2001	Jul 2002	Jul 2003	Jul 2004	Jul 2005	Jul 2006	Mar 2007		
APPROVED PROPOSALS																																								
Completed and Data Analysis	0	0	0	16	57	97	152	190	234	248	264	278	295	297	300	310	324	326	339	341	348	355	363	389	389	389	396	396	403	405	412	415	417	418	419	424	431	436		
Remaining and Inactive	21	53	70	75	89	121	100	82	57	52	41	41	29	33	43	48	39	42	34	43	38	34	20	24	28	30	25	34	30	32	31	31	32	36	41	43	46	44		
Subtotals	21	53	70	91	146	218	252	272	291	300	305	319	324	330	343	358	363	368	373	384	386	389	403	413	417	419	421	430	433	437	443	446	449	454	460	467	477	480		
PENDING PROPOSALS																																								
Unconsidered	23	16	19	10	0	2	6	12	6	6	13	27	16	25	11	8	8	13	13	11	21	50	36	17	6	8	9	11	11	15	7	5	7	8	5	5	3	7		
Deferred	29	35	39	43	54	45	25	24	11	2	10	7	9	11	2	0	1	0	0	0	0	0	2	3	1	1	0	0	0	1	1	1	1	1	1	1	1	1	1	2
"Not Approved"	0	0	0	0	0	0	0	0	0	0	0	0	1	1	1	1	1	1	1	1	1	1	1	1	1	1	1	1	1	1	1	1	1	1	1	1	1	1	1	4
Subtotals	52	51	58	53	54	47	31	36	17	8	23	34	26	37	14	9	10	14	14	14	12	22	51	39	21	8	10	10	10	12	12	16	9	7	9	10	7	7	8	13
OBSOLETE PROPOSALS																																								
Rejected	8	15	20	42	65	85	135	166	185	189	191	210	221	229	231	234	236	237	239	241	242	243	245	247	251	250	250	250	251	255	256	257	257	257	258	258	259	259		
Withdrawn/Inactive	1	33	35	47	61	71	80	93	114	127	131	139	147	149	159	163	166	168	169	168	169	170	173	191	196	198	201	202	206	209	210	210	210	210	213	213	213	213	213	213
Subtotals	9	48	55	89	126	156	215	259	299	316	322	349	368	378	390	397	402	405	408	409	411	413	418	438	447	448	451	452	457	460	465	466	467	470	471	471	471	472	472	
TOTAL NUMBER OF	82	152	183	233	326	421	498	567	607	624	650	702	718	745	747	764	775	787	795	805	819	853	860	872	872	877	882	884	894	902	913	917	919	925	934	938	945	957	965	

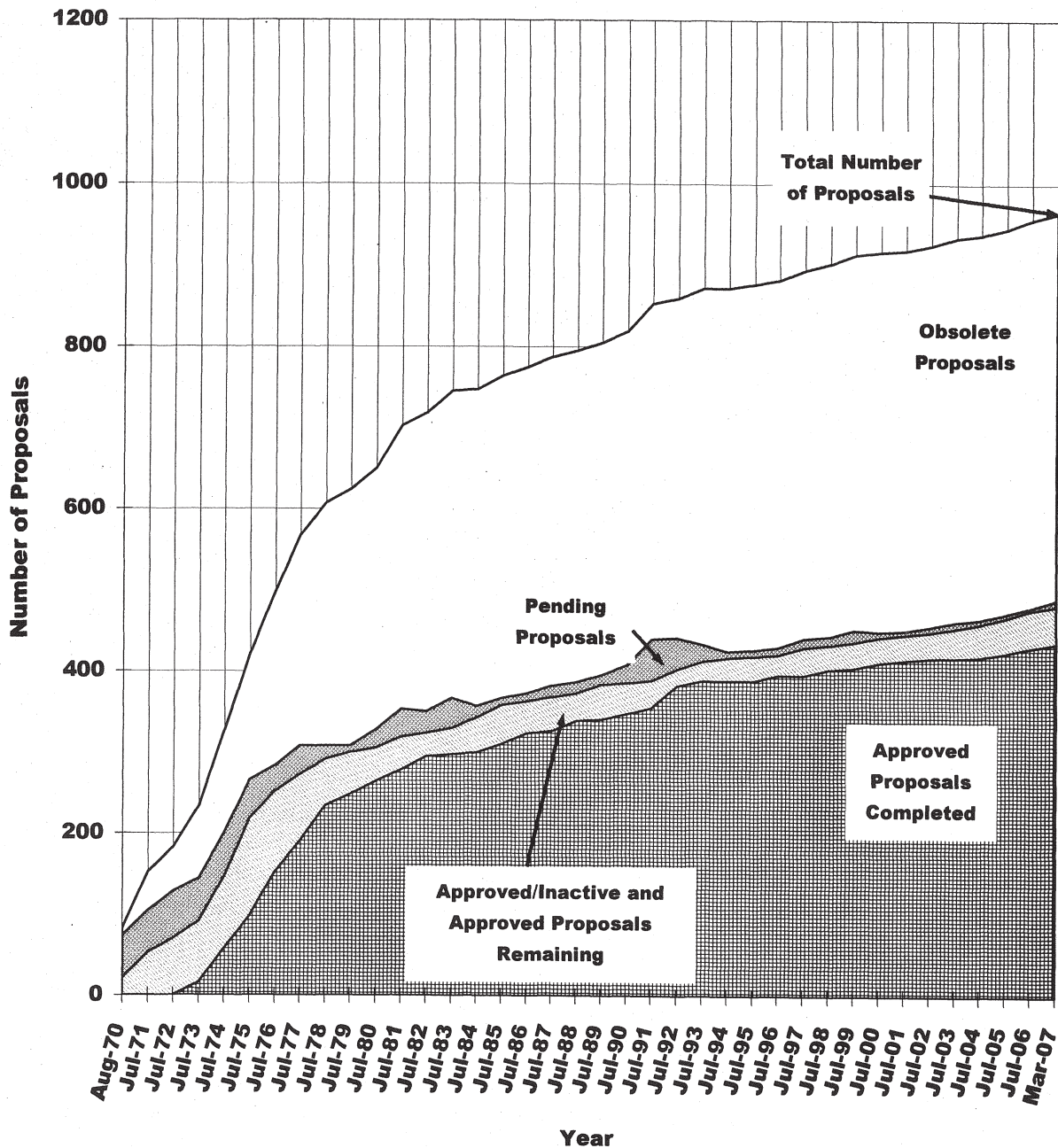

Figure 1. Growth of the Fermilab research program. The total number of approved experiments is obtained by adding the numbers shown as completed and those remaining and approved/inactive. Pending proposals are those which are unconsidered, deferred or "not approved;" obsolete proposals are rejected or withdrawn/inactive. Note that in this figure "Approved Proposals Completed" includes experiments still analyzing data.

SECTION II. ACCELERATOR PERFORMANCE

This Section gives summaries of Tevatron operation for the current 980 GeV \times 980 GeV $\bar{p}p$ Collider run (Run II) which started in 2001, and also (Figure 5) a comparison of the integrated luminosities for Collider Runs Ia, Ib, and II.

Collider Run II Integrated Luminosity

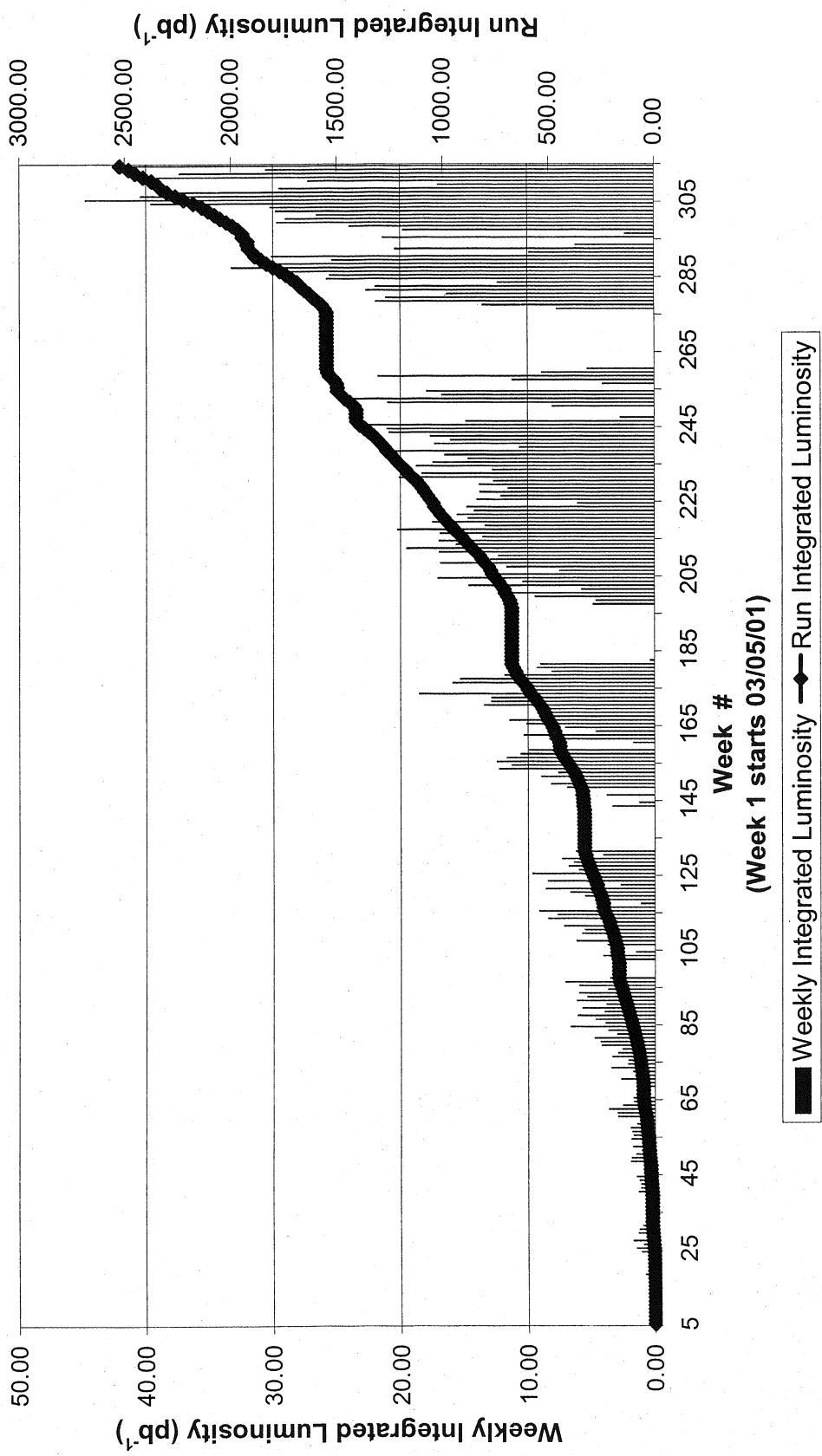

Figure 2. Tevatron Collider operation during the current running period, which started in 2001 - luminosity per week and integrated luminosity.

Collider Run II Pbar Stacking

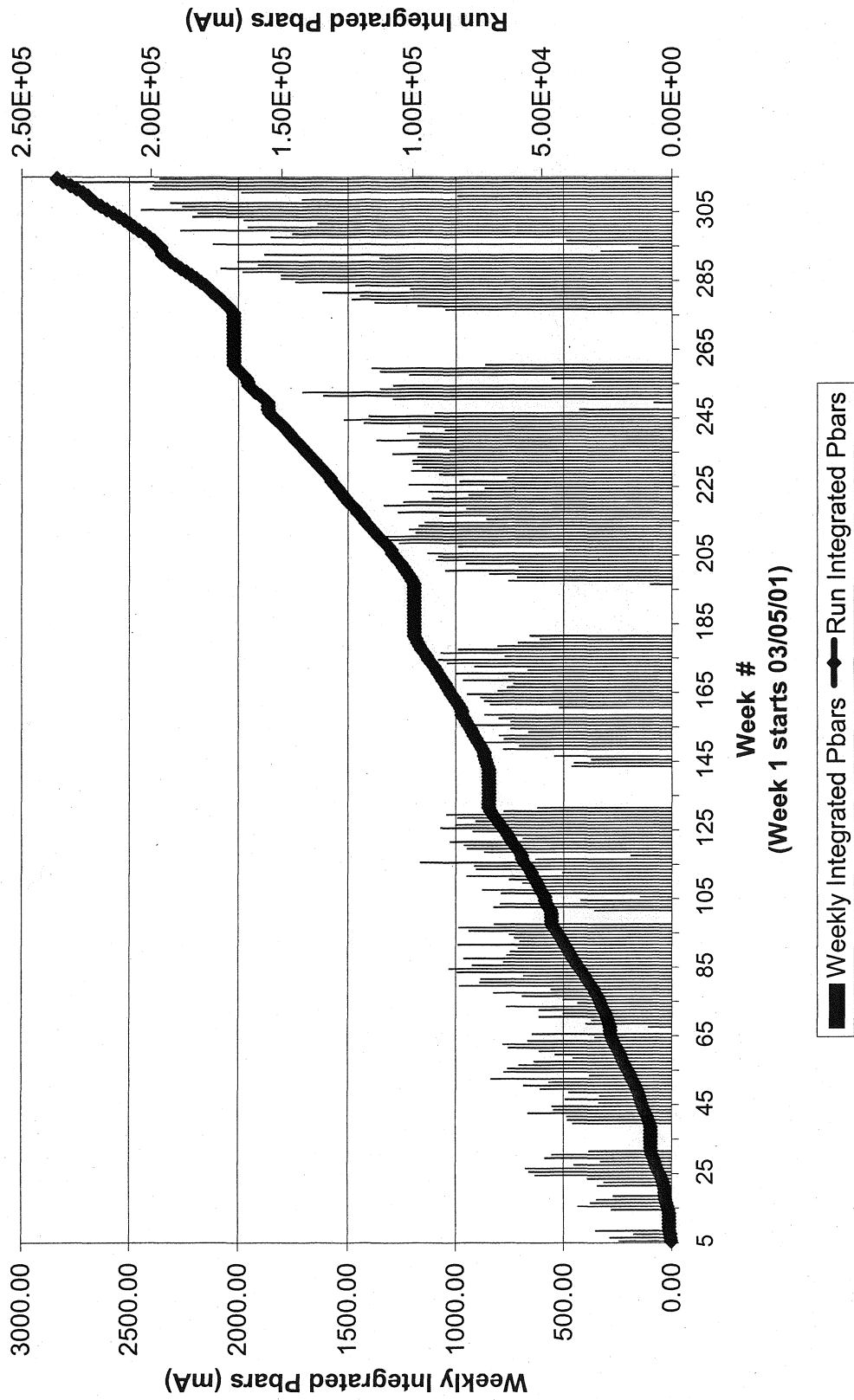

Figure 3. Tevatron Collider operation during the current running period, which started in 2001 - antiproton stacking per week and integrated stacking.

Collider Run II Peak Luminosity

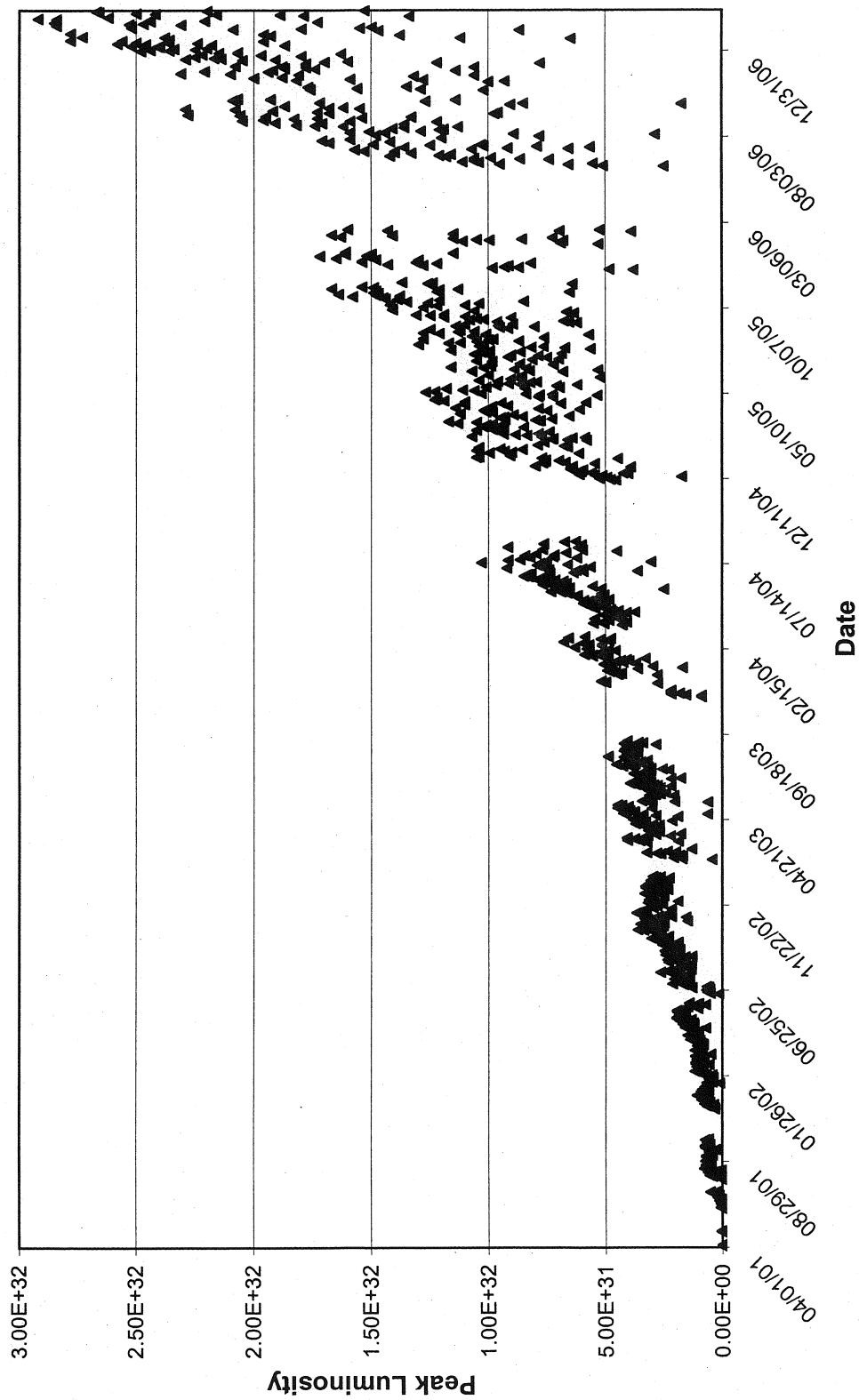

Figure 4. Tevatron Collider operation during the current running period, which started in 2001 - daily peak luminosity.

Multi-Run Integrated Luminosity

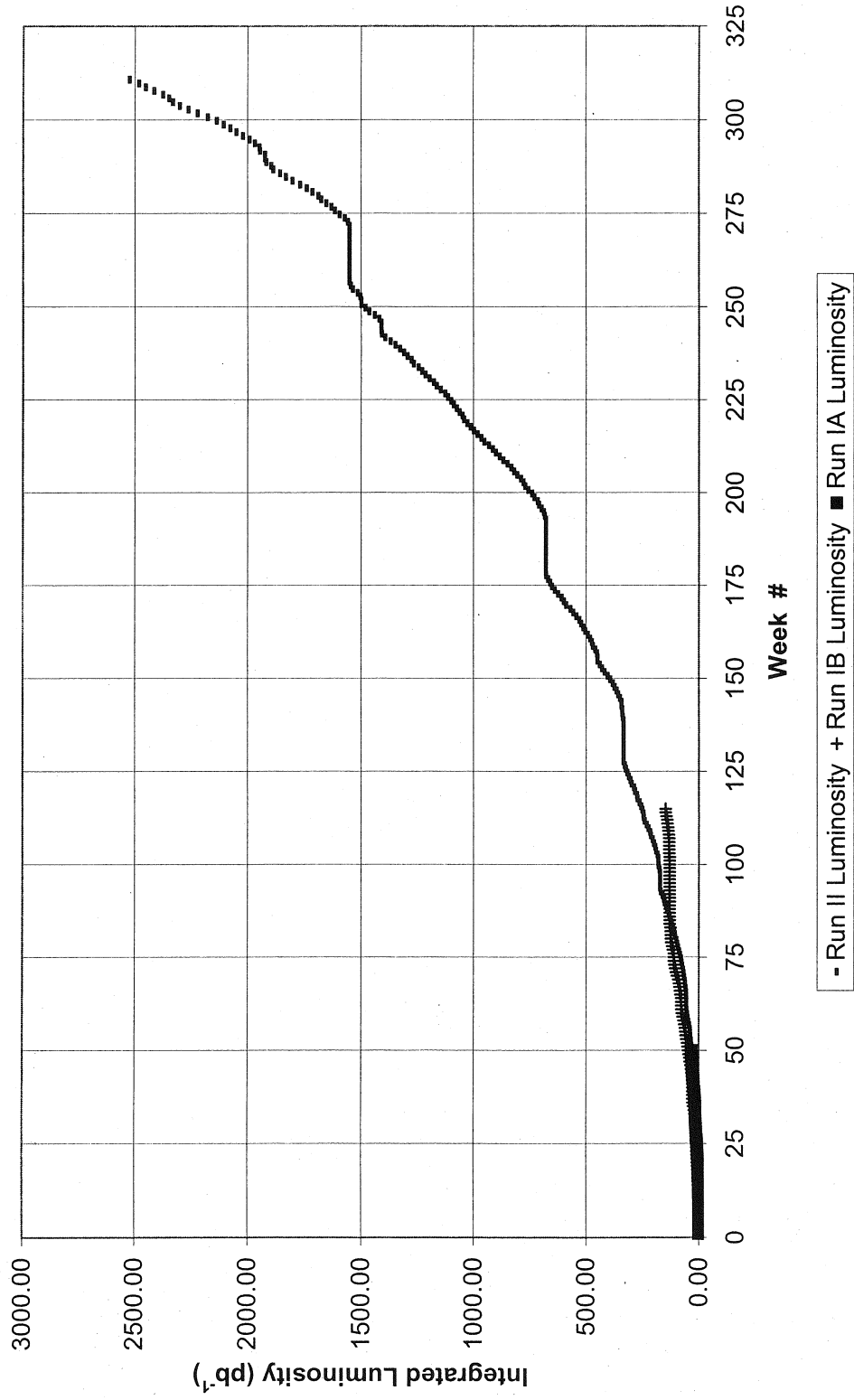

Figure 5. Comparison of the integrated luminosities for Collider Runs Ia, Ib, and II.

SECTION III. FERMILAB BEAM PROPERTIES AND EXPERIMENT LOCATION

The locations of all Fermilab fixed-target area beamlines are shown in Figure 6; Figure 7 gives the locations of Collider experiments.

The currently approved neutrino experiments use beams from the Booster (for experiment E-944, MiniBooNE Antineutrino) and the Main Injector (the NuMI beam for experiment E-875, MINOS). The locations of these experiments are shown on the overall Fermilab accelerator schematic layout in Figure 8, and their expected or measured beam fluxes are shown in Figures 9 and 10. The test beam MT is located in the Meson Area.

Table 2 gives the number of 120 GeV Main Injector protons/hour that can be expected under various operating scenarios, and Figure 11 shows some expected secondary beam fluxes using the Main Injector. Some more detailed information on the MT test beam is given on page 19, and in Table 3 and Figure 12.

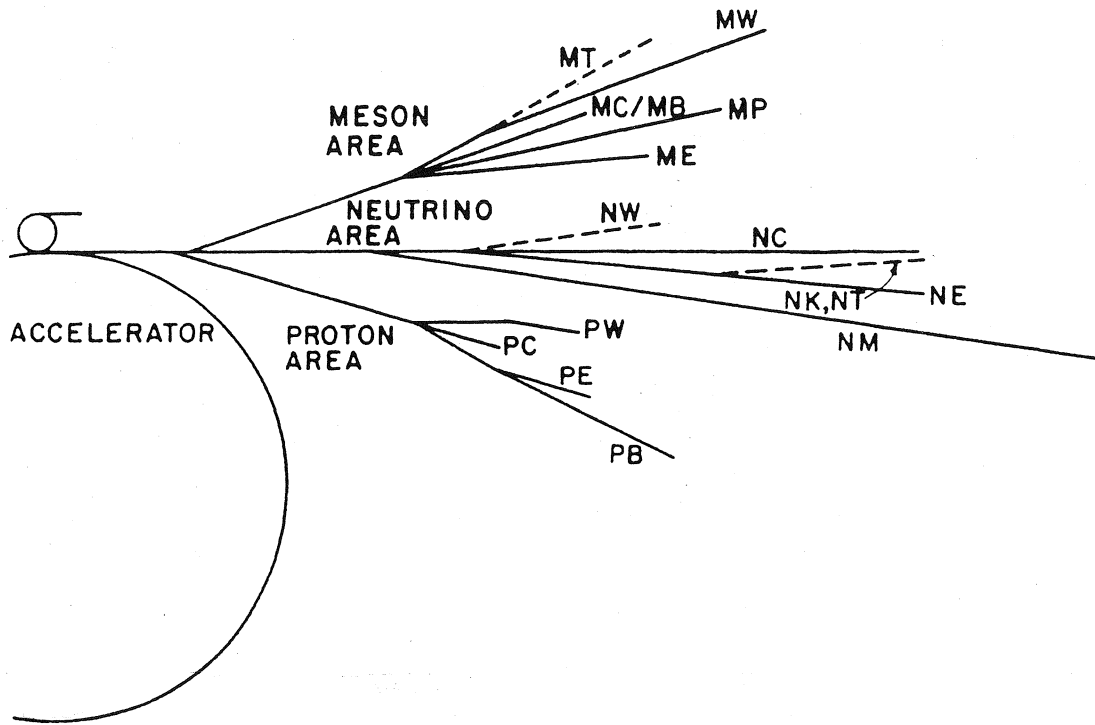

Figure 6. Layout of Fermilab Fixed Target area beams.

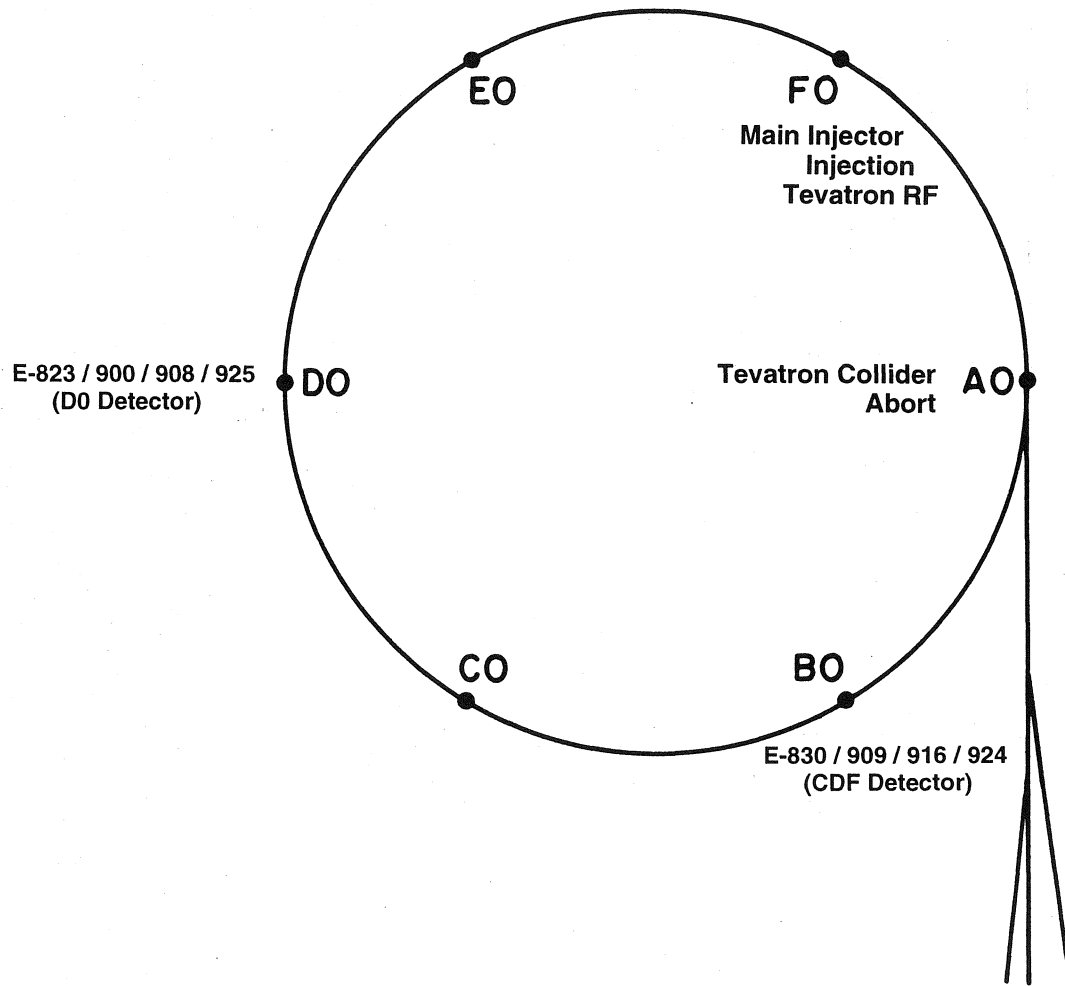

Figure 7. Locations in the Tevatron of the approved $p\bar{p}$ Collider experiments.

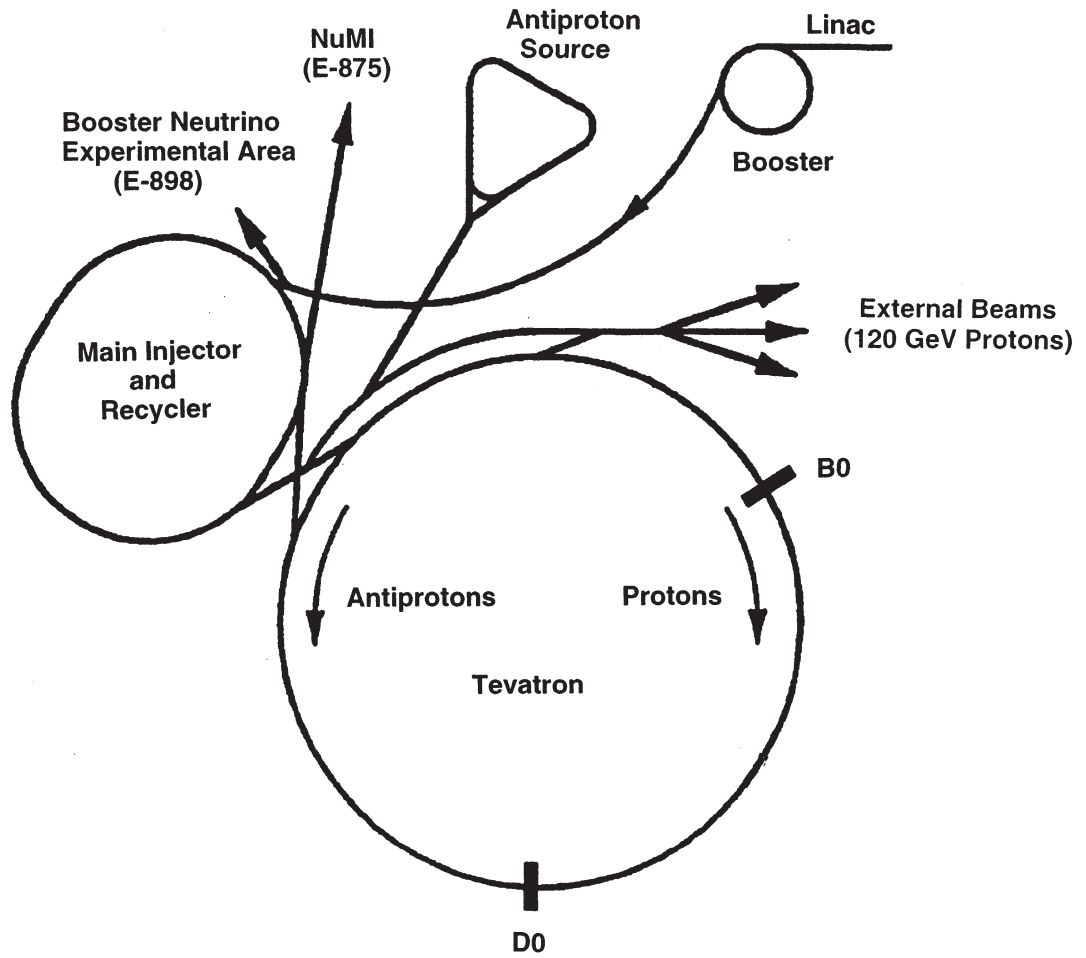

Figure 8. Schematic layout of Fermilab accelerators with present experimental areas.

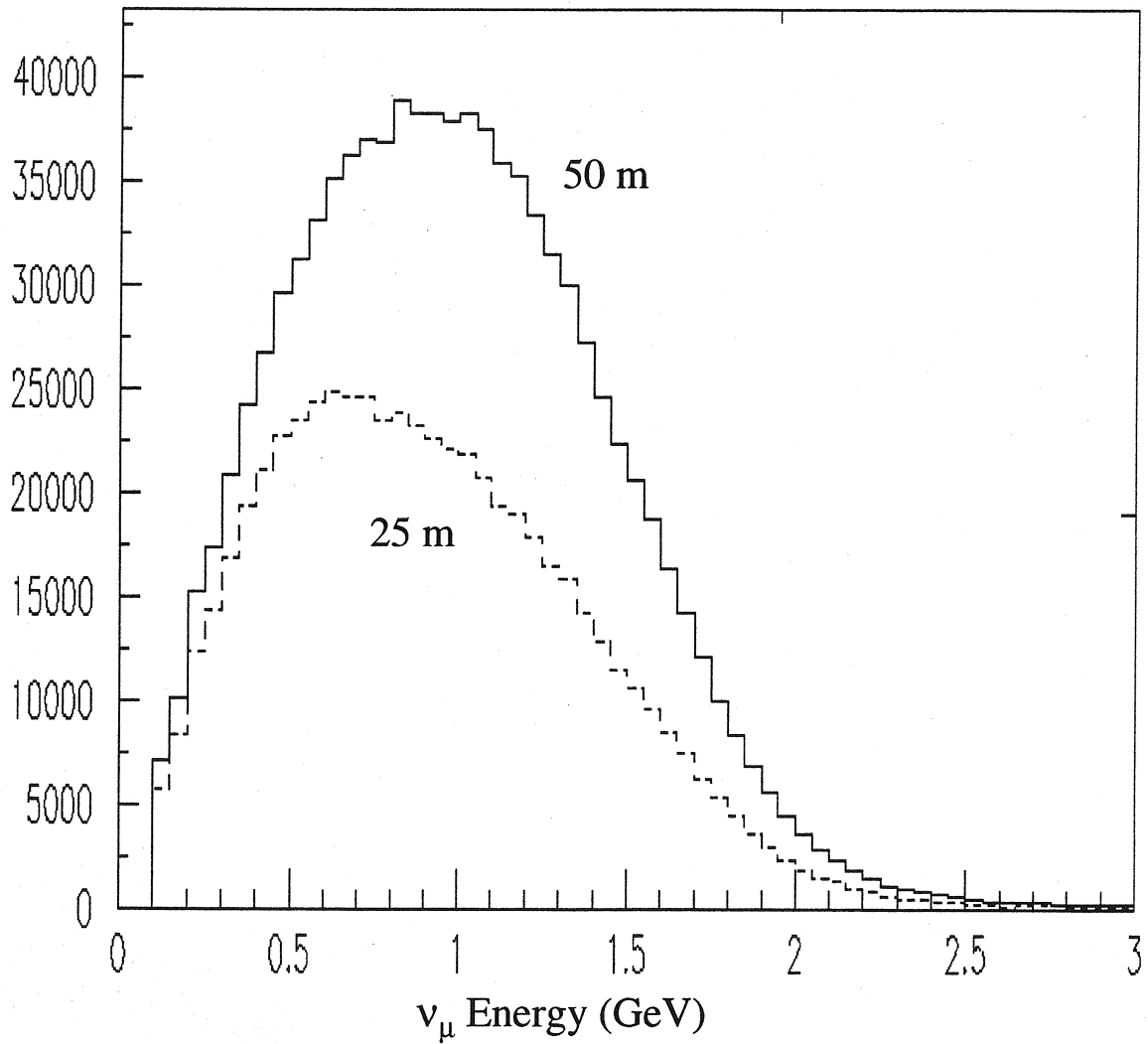

Figure 9. Predicted neutrino flux at the MiniBooNE detector, for 4.7×10^9 protons on a beryllium target, through a 2.5 m-radius circle at 541 m from the target. The data are for a single magnetic-focusing horn. MiniBooNE expects to run with both a 25 m and a 50 m decay pipe.

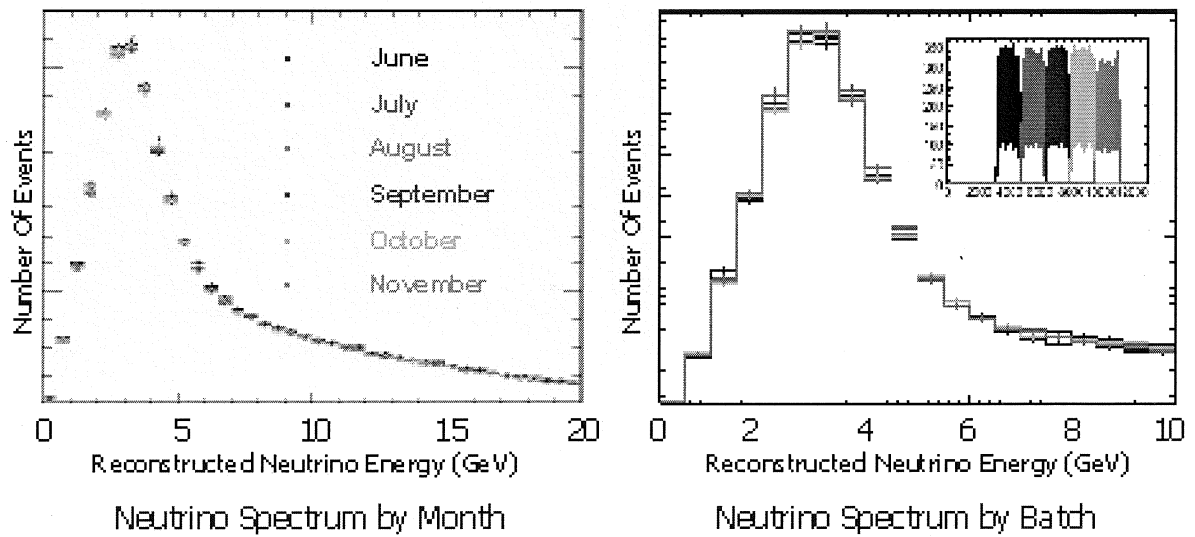

Figure 10. NuMI facility neutrino spectrum as observed by the MINOS experiment Near Detector, showing the beam stability by 2006 month and by Booster batch.

**TABLE 2. PROTONS PER HOUR UNDER VARIOUS
MODES OF OPERATION**

<u>Mode</u>	<u>Cycle Time</u>	<u>Protons/Hour</u>		
		<u>AP Target</u>	<u>Fast Spill</u>	<u>Slow Spill</u>
Antiproton Production	*	1.2×10^{16}	--	--
Fast Spill	1.866	--	5.8×10^{16}	--
Slow Spill	2.866	--	--	3.8×10^{16}
Mixed: AP+Fast Spill	2.000	0.9×10^{16}	4.5×10^{16}	--
Mixed: AP+Slow Spill	3.000	0.6×10^{16}	--	3.0×10^{16}

[Assumptions: 6×10^{10} protons per bunch; additional time is required for bunch manipulations and turning off magnetic switch at F17 in mixed modes.]

* 2.4 sec (current)
1.6 sec (future)

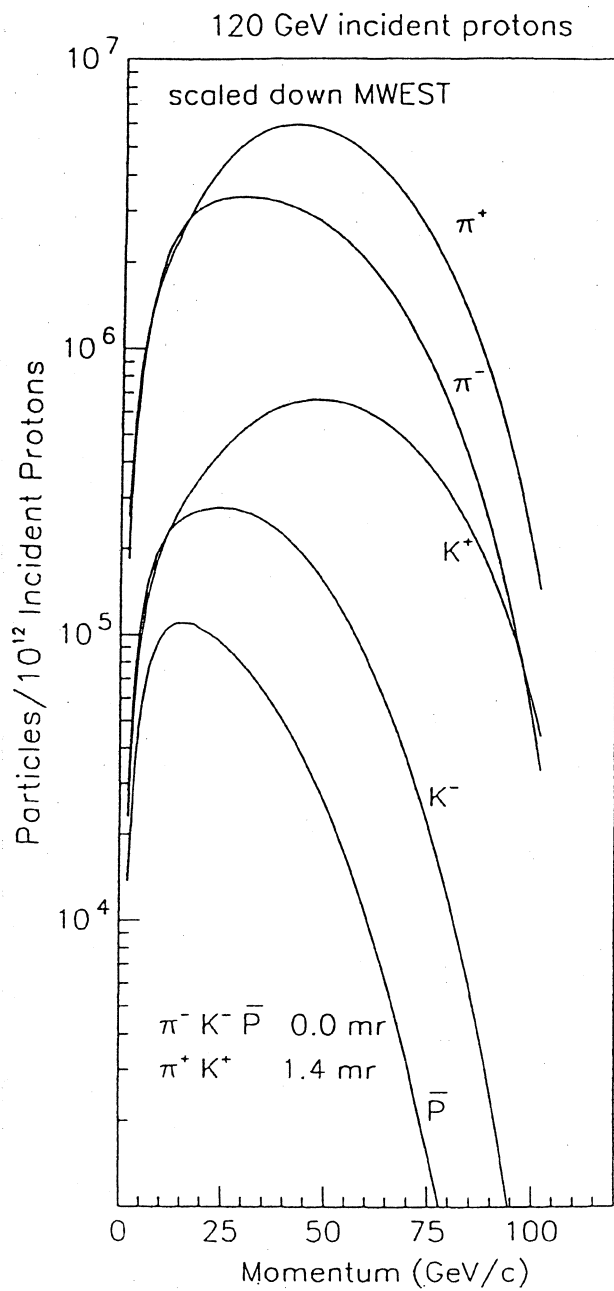

Figure 11. Main Injector: Fluxes scaled from the 800 GeV MW beamline.

Meson Test Beam Facility

The Meson Test Beam Facility, shown in Figure 12, is a shielded user experimental area located in the Meson Detector Building at Fermilab, with approximately six locations in line where users can set up equipment for testing. It uses 120 GeV protons from the Main Injector on a 30-cm aluminum target to produce a general-purpose unseparated secondary beam. The proton spill length is 4.0 seconds, with normally one spill per minute for 12 hours per day. Some running is possible at a higher repetition rate, if approved by the Accelerator Division.

The beamline can be tuned to 120 GeV to provide non-interacting Main Injector beam protons. The intensity for this tune is administratively limited to less than 700 kHz; the highest rate that has been achieved so far is about 100 kHz. Beam momenta below 64 GeV can also be obtained, with rates depending on the specific momentum (on the order of 50 kHz for 66 GeV down to a few hundred Hz for 5 GeV). The composition of the beam is mostly protons for the higher momentum tunes and mostly pions below 40 GeV. The lowest momentum tunes will have a high proportion of electrons. The spot size is typically one cm for 120 GeV beam and a few cm for the secondary beams.

Beam particle identification is available, using two threshold Cerenkov counters. There are secondary targets in the beamline, as well as sweeper magnets and converters, that can be used to deliver a larger fraction of electrons in the beam. Finally, there is a beam absorber in the middle of the user areas such that only muons can be delivered downstream of that point.

There are two major sections for users: the upstream, smaller section called MT6-section 1, which has two experimental areas, and the downstream, larger area called MT6-section 2, which has four experimental areas. One of the areas in each section is a sheltered, air-conditioned hut for cleaner operations. Each area has gas delivery and exhaust lines leading to it. Each area also has a limited number of high voltage and signal cables going to it, and the user can install more.

There are a total of seven MWPC stations scattered throughout the facility. Three of these are read out by the accelerator control system on a spill by spill basis, and show the current conditions of the beam to the accelerator operators. The other four MWPC stations, located in MT6B, are for use by experimenters for particle tracking. In addition, there are two scintillation counters along the beamline for triggering purposes and time-of-flight measurements. For use of the test beam and information on support available, contact the test beam coordinator, Erik Ramberg (ramberg@fnal.gov).

Table 3 gives some Meson Test particle rates.

TABLE 3. MESON TEST PARTICLE RATES

Particle Energy (GeV)	MT6SC2 rate normalized to 1×10^{12} protons/spill (from MI to SY 120)	Electron Fraction
120	400-450K	0
66	35-40K	~0
33	30K	~0.7%
16	17K	~10%
8	2.5-5.0K	~30%
4	220-330 700	~60%
3	160	

Notes

The spill length is 4 sec. Flattop for beam extraction is 4 sec. At present, one spill every minute for 12 hours per day is allocated to SY120.

At lower energies, especially at 8 GeV and below, a movable target can be inserted halfway down the beamline to increase the rates beyond those indicated in Table 3.

Shielding limit in MTest is

- a. 2×10^{12} protons/2.9 sec from M02 to M03 pinhole collimator
- b. 2×10^7 particles/2.9 sec from M03 pinhole collimator and downstream.

MT6 Test Beam User Areas

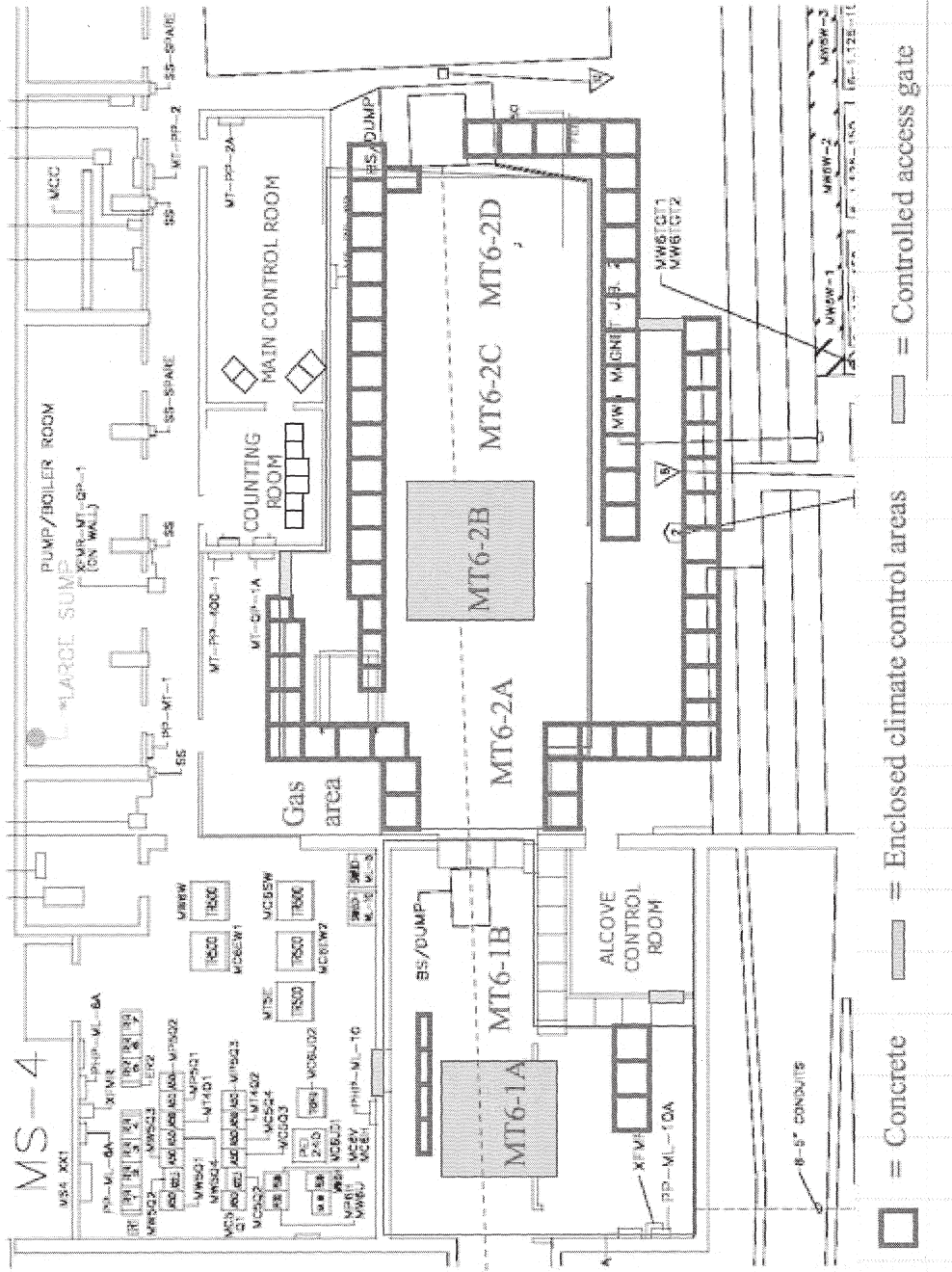

Figure 12. Layout of Meson Test Beam Facility.

SECTION IV. MAJOR RESEARCH ACTIVITIES DURING 2006 AND 2007

Information on the Fermilab research program during 2006 and early 2007 is given in the following pages. Figure 13 shows when beam was delivered to the experiments; Table 4 describes the major research activities in a little more detail.

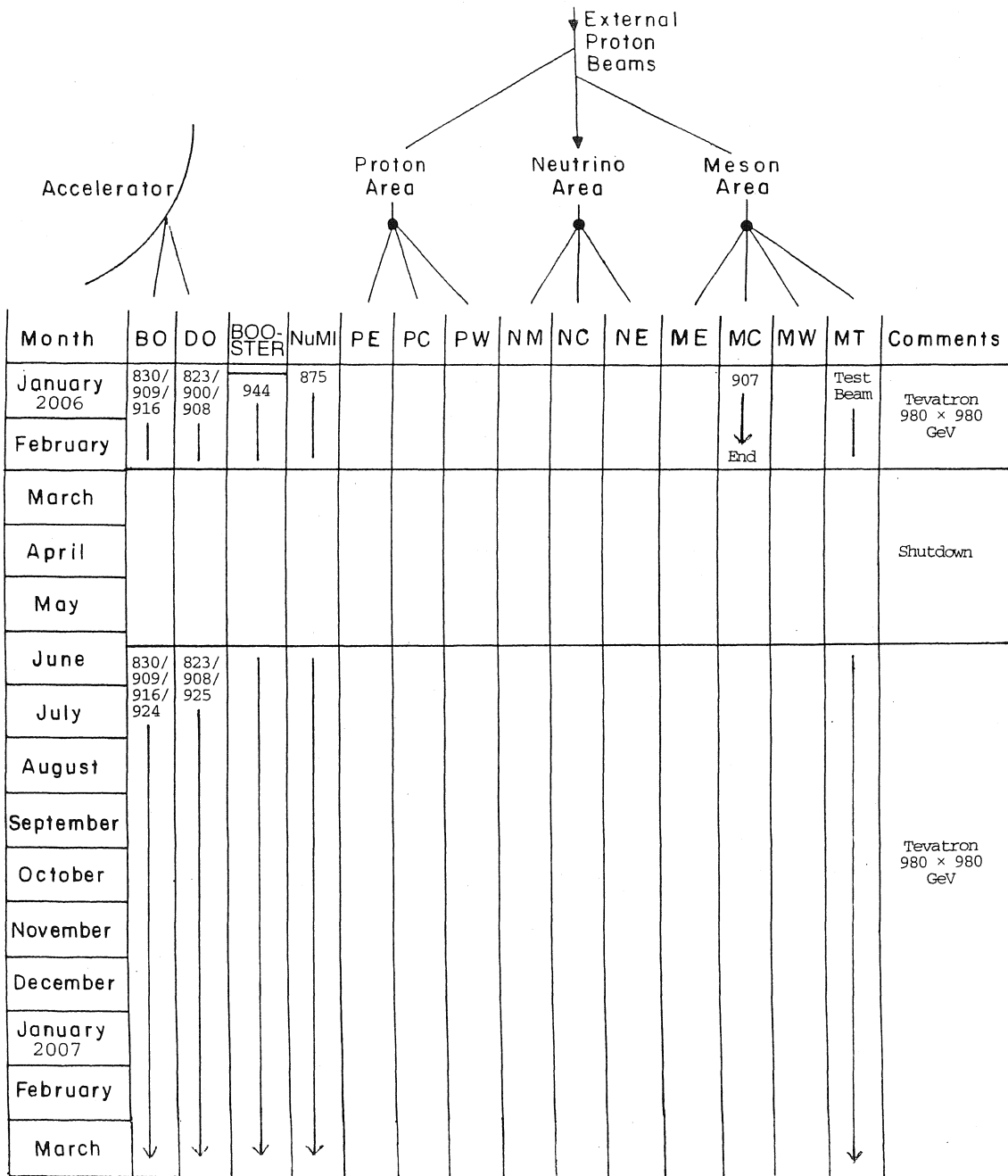

Figure 13. Major experiments running at Fermilab in 2006 and 2007 (through March).

**TABLE 4. DESCRIPTION OF MAJOR RESEARCH ACTIVITIES
DURING 2006 AND 2007 (through March)**

<u>EXP. #</u>	<u>AREA</u>
<u>BOOSTER</u>	
944	MiniBooNE Extension – antineutrino data-taking
907	MIPP – completion of data-taking
<u>MAIN INJECTOR</u>	
875	MINOS – data-taking
<u>COLLIDER</u>	
830 / 909 / 916 / 924	CDF – data-taking
823 / 908 / 925	D0 – data-taking

SECTION V. FERMILAB RESEARCH PROGRAM

This Section contains information on the Fermilab research program for the next few years. The Situation Report, given on the following two pages, is a summary of the current status of the experimental program. Figure 14, based on the Situation Report, illustrates by beam line the major approved experiments using the Fermilab accelerator complex that have not yet completed data-taking. Figure 15 illustrates significant Fermilab activities other than those shown in Figure 14.

Fermi National Accelerator Laboratory Experiment Program Situation Report as of March 1, 2007

The Experimental Program situation at Fermilab is summarized below. The experiments are listed by experimental area and beamline under categories that best describe their status as of March 1, 2007. The experimental area names are abbreviated as follows: Meson Area (MA); Neutrino Area (NA); Proton Area (PA); Collision Area (COL); Accumulator Ring (ACCUM RING); Debuncher Ring (DBNCHR RING); Booster Accelerator (BOOSTR); Unspecified (UNSPEC BEAM); Main Injector (MI); and A0 Facility (A0 Facility).

Total number of approved experiments - 480

Beam	Area & Line	Experiment	Spokesperson(s)	Completion Date
EXPERIMENTS THAT ARE COMPLETED (426)				
<i>(Note: Only experiments which were completed since January 1, 2002 are listed.)</i>				
MA	MT	RICE TEST #T926	(BEAN)	MAY 15, 2005
		BTEV PIXEL DETECTOR TEST #T927	(BUTLER, STONE)	FEB 01, 2007
		BTEV STRAW TESTS #T930	(BUTLER, STONE)	FEB 01, 2007
		BTEV MUON DETECTOR TEST #T931	(JOHNS)	FEB 15, 2005
		BTEV EM CALORIMETER TEST #T933	(SEMENOV)	FEB 01, 2007
		BTEV RICH TEST #T935	(ARTUSO)	JAN 15, 2005
		US-CMS PIXEL DETECTOR TEST #T936	(WORM)	JUL 24, 2006
		PPAC #T941	(NORBECK)	JAN 15, 2005
		MONOLITHIC ACTIVE PIXEL DETECTOR #T943	(VARNER)	JAN 15, 2005
		ALICE EMCAL #T951	(AWES)	DEC 04, 2005
		MICROPARTICLE SHIELDING #T959	(HERTEL)	DEC 20, 2006
NA	NC	NEUTRINO #815	(BERNSTEIN, SHAEVITZ)	MAR 01, 2005
COL	B-0	CDF UPGRADE #775	(KIM, RISTORI)	MAR 01, 2005
		CDF HARD DIFFRACTION STUDIES #876	(ALBROW)	FEB 01, 2004
	C-0	BTEV R&D #897	(BUTLER, STONE)	JAN 01, 2002
	D-0	D-0 DETECTOR #740	(GRANNIS, MONTGOMERY)	MAR 01, 2005
ACCUM RING		CHARMONIUM STATES #835	(CESTER, PORDES)	JAN 01, 2006
MAIN INJECTOR		MINOS VETO SHIELD PROTOTYPE #T928	(MICHAEL, WOJCICKI)	JUL 22, 2003
OTHER		SEARCH FOR LOW MASS MONOPOLES #882	(KALBFLEISCH)	FEB 01, 2004
		LHC ACCELERATOR #893	(KERBY)	NOV 01, 2006
		RECYCLER ELECTRON COOLING #901	(NAGAITSEV)	MAY 31, 2004
A0 FACILITY		PLASMA WAKE-FIELD ACCELERATOR TEST #890	(ROSENZWEIG)	FEB 01, 2004

EXPERIMENTS THAT ARE ANALYZING DATA (10)				Last Run
MA	MC	CP VIOLATION #871	(DUKES, LUK)	JAN 21, 2000
NA	NM	CP VIOLATION #799	(TSCHIRHART)	JAN 17, 2000
		CP VIOLATION #832	(BLUCHER)	JAN 17, 2000
PA	PB	HEAVY QUARK PHOTOPRODUCTION #831	(CUMALAT, MORONI)	AUG 25, 1997
	PC	LARGE-X BARYON SPECTROMETER #781	(RUSS)	SEP 03, 1997
	PW	TAU NEUTRINO #872	(TZANAKOS, PAOLONE)	SEP 03, 1997
COL	D-0	D0 FORWARD PROTON DETECTOR #900	(BLAZEY, WYATT)	FEB 27, 2006
MI	MC	PARTICLE PRODUCTION #907	(RAJA)	FEB 27, 2006
BOOSTER		MINIBOONE #898	(CONRAD, LOUIS)	JAN 23, 2006
OTHER		SLOAN DIGITAL SKY SURVEY #885	(KENT)	JUN 30, 2005

EXPERIMENTS THAT ARE IN PROGRESS (22)

MA	MT	VACUUM STRAW TRACKER #T950	(WAH)
		CERENKOV TEST #T953	(NORBECK)
		RPC TEST #T955	(UNDERWOOD)
		ILC MUON DETECTOR #T956	(ABRAMS)
		TAIL-CATCHER/MUON #T957	(ZUTSHI)
		FP420 FAST TIMING #T958	(BRANDT)
COL	B-0	CDF UPGRADE #830	(KONIGSBERG, ROSER)
		CDF INNER SILICON AND TOF #909	(KONIGSBERG, ROSER)
		CDF MINIPLUGS #916	(KONIGSBERG, ROSER)
		CDF RUN IIB UPGRADE #924	(KONIGSBERG, ROSER)
	D-0	D0 DETECTOR UPGRADE #823	(DENISOV, WYATT)
		D0 SILICON TRACK TRIGGER #908	(DENISOV, WYATT)
		D0 RUN IIB UPGRADE #925	(DENISOV, WYATT)
	NUMI	NEUTRINO OSCILLATIONS #875	(PLUNKETT, WOJCICKI)
		MINOS VETO SHIELD #934	(PLUNKETT, WOJCICKI)
		PEANUT #T952	(NIWA)
BOOSTER		MINIBOONE ANTINEUTRINO #944	(BRICE, VAN DE WATER)
OTHER		AUGER PROJECT R&D #881	(MANTSCH)
		CDMS #891	(BAUER)
		COUPP #T945	(COLLAR)
		SDSS-II #949	(KENT)
A0 FACILITY		EXPERIMENTS AT THE A0 PHOTOINJECTOR #886	(EDWARDS, FILLER)

**Fermi National Accelerator Laboratory
Experiment Program Situation Report as of March 1, 2007**

*(Continued)***EXPERIMENTS THAT ARE TO BE SETUP WITHIN A YEAR (5)**

MA	MT	DIAMOND DETECTOR TEST #T932	(WORM)
BOOSTER		SCIBOONE #954	(NAKAYA, WASCKO)
OTHER		CMS AT FERMILAB #892	(BUTLER)
		US CMS SILICON TRACKER #919	(BUTLER)
		COUPP #961	(COLLAR)

OTHER APPROVED EXPERIMENTS (4)

MI	NUMI	NOVA #929	(FELDMAN, MESSIER)
		HIGH-STATISTICS NEUTRINO SCATTERING #938	(MCFARLAND-PORTER, MORFIN)
MI	UNSPEC	ANTI(D-QUARK)/ANTI(U-QUARK) DIST#906	(GEESAMAN, REIMER)
OTHER		DARK ENERGY SURVEY #939	(ANNIS, FLAUGHER)

PENDING PROPOSALS (7)

MA	MT	MINI LAR TPC #T962	(FLEMING)
		STAR MUON TELESCOPE #T963	(XU)
		GDH #T964	(YU)
		PHOTOSENSOR TESTS #T965	(WILSON)
COL	B-0	CDF FORWARD DETECTORS #920	(ALBROW)
UNSPEC BEAM		MUON COOLING R&D #904	(GEER)
OTHER		SUPERCDCMS #947	(BAUER)

Collider

B0 —	830/909/916/924 Konigsberg / Roser	ANL, Barcelona, Baylor, Bologna, Brandeis, UC/Davis, UCLA, UCSB, UCSD, Cantabria, Carnegie Mellon, Chicago, CIEMAT, Comenius, Duke, Fermilab, Florida, Frascati, Geneva, Glasgow, Harvard, Helsinki, Illinois, IPP/McGill/Toronto, ITEP, JINR, Johns Hopkins, Karlsruhe, KEK, Korea Center for HEP, LBNL, Liverpool, Michigan, MIT, New Mexico, Northwestern, Ohio State, Okayama, Osaka City, Oxford, Padova, Paris VI, Pennsylvania, Pisa, Pittsburgh, Purdue, Rochester, Rockefeller, Rome, Rutgers, Taiwan, Texas A&M, Trieste/Udine, Tsukuba, Tufts, Univ. Coll. London, Waseda, Wayne State, Wisconsin, Yale	CDF Detector
------	---------------------------------------	--	--------------

D0 —	823/908/925 Denisov / Wyatt	Aachen, Alberta, los Andes, Arizona, BNL, Bonn, Boston, Brown, Buenos Aires, UC/Riverside, CBPF, Charles, CINVESTAV, Clermont-Ferrand, Columbia, CSU/Fresno, Czech Acad. Sci., Czech Tech, Delhi, Estadual Paulista, Fermilab, Florida State, Grenoble, IHEP/Protvino, Illinois/Chicago, Imperial Coll., Indiana, Iowa State, ITEP, JINR, Kansas, Kansas State, Korea, Lancaster, Langston, LBNL & UC/Berkeley, Louisiana Tech, LMU Munich, Lyon, Mainz, Manchester, Marseille, Maryland, McGill, Michigan, Michigan State, Mississippi, Moscow State, Nebraska, Nijmegen/NIKHEF, NIKHEF/Amsterdam, Northeastern, Northern Illinois, Northwestern, Notre Dame, Oklahoma State, Orsay, Panjab, Paris VI & VII, PNP, Princeton, Purdue/Calumet, Quito, Rice, Rio de Janeiro, Rochester, Saclay, Simon Fraser, Southern Methodist, Strasbourg, Sung Kyun Kwan, SUNY/Bufalo, SUNY/Stony Brook, Swedish Consortium, Tata, Texas/Arlington, Univ. Coll. Dublin, UST/China, Virginia, Washington, Wuppertal, York	D0 Detector
------	--------------------------------	--	-------------

Booster

—	944 Brice / Van De Water	Alabama, Bucknell, Cincinnati, Colorado, Columbia, Embry Riddle, Fermilab, Imperial Coll., Indiana, LANL, Louisiana State, Michigan, Princeton, St. Mary's, VPI, Western Illinois, Yale	MiniBooNE Antineutrino
---	-----------------------------	---	---------------------------

—	954 Nakaya / Wascko	Barcelona, Chonnam, Cincinnati, Colorado, Columbia, Dongsin, Fermilab, ICRR Tokyo, Imperial Coll., Indiana, KEK, Kyoto, LANL, Louisiana State, Purdue/Calumet, Rome, St. Mary's, Seoul, Tokyo Inst. Tech., Valencia	SciBooNE
---	------------------------	---	----------

Main Injector

—	875/934 Plunkett / Wojcicki	ANL, Athens, Benedictine, BNL, Caltech, Cambridge, Campinas, Fermilab, Collège de France, Harvard, IHEP/Protvino, IIT, Indiana, ITEP, Lebedev, Minnesota, Minnesota/Duluth, Oxford, Pittsburgh, Rutherford, São Paulo, South Carolina, Stanford, Sussex, Texas A&M, Texas/Austin, Tufts, Univ. Coll. London, Western Washington, William & Mary, Wisconsin	MINOS
---	--------------------------------	--	-------

—	906 Geesaman / Reimer	Abilene Christian, ANL, Colorado, Fermilab, Illinois, JLab, LANL, Maryland, Rutgers, Texas A&M, Valparaiso	$\bar{d}(x) / \bar{u}(x)$ Distribution
---	--------------------------	--	--

—	938 McFarland / Morfin	Athens, UC/Irvine, Dortmund, Fermilab, Hampton, IIT, INR Moscow, James Madison, JLab, Minnesota/Duluth, Northern Illinois, Northwestern, Peru/PUC, Peru/UNI, Pittsburgh, Rochester, Rutgers, St. Xavier, Texas/Austin, Tufts, William & Mary	MINERVA
---	---------------------------	--	---------

—	929 Feldman / Messier	ANL, Athens, UCLA, Caltech, Fermilab, Collège de France, Harvard, Indiana, ITEP, Michigan State, Minnesota/Twin Cities, Minnesota/Duluth, Northern Illinois, Ohio State, Rio de Janeiro, South Carolina, Southern Methodist, Stanford, Texas A&M, Texas/Austin, Texas/Dallas, Tufts, Virginia, William & Mary	NOVA
---	--------------------------	---	------

Figure 14. Fermilab experimental program, showing all major approved particle physics experiments that have not yet completed data-taking.

Accelerator R&D

Linear Collider	Kephart	ANL, CERN, Cornell, DESY, Fermilab, India, INFN, JLab, KEK, MSU, Northern Illinois, Northwestern, Penn/TRIUMF, SLAC, Wisconsin/NHMFL
New Muon Lab Test Facility	Nagaitsev	ANL, Cockcroft Inst., DESY, Fermilab, INFN, KEK, NIU, Rochester, SLAC
Photoinjector Laboratory (FAOPL)	Edwards / Filler	ANL, Cornell, Fermilab, Illinois, Oxford, Rutgers
Muon Collider	Geer / Shiltsev	ANL, BNL, Fermilab, IIT, JLab, LBNL, Mississippi, Muons, Inc.
MuCool / MICE	Bross / Blondel	ANL, BINP, BNL, Brunel, UCLA, UC/Riverside, CERN, Cockcroft, Inst, Daresbury, Fairfield, Fermilab, Geneva, Glasgow, Harbin Inst. of Tech., IIT, Imperial Coll., Iowa, JLab, KEK, Kyoto, LBNL, Liverpool, Milano, Mississippi, Napoli, NIKHEF, Northern Illinois, Osaka, Paul Scherrer Inst., Roma III, Rutherford, Sheffield, Sofia, Trieste
LHC Accelerator Research Program (LARP)	Peggs	BNL, Fermilab, LBNL, SLAC, Texas/Austin
High-Field Superconducting Magnets	Zlobin	BNL, CERN, Fermilab, Florida State/NHMFL, LBNL, NIMS/Japan, Ohio State
High Intensity Neutrino Source	Apollinari	ANL, BNL, Fermilab, LBNL

US CMS

US CMS	Newman (CMS - Virdee)	Boston, Brown, UC/Davis, UCLA, UC/Riverside, UC/San Diego, UCSB, Caltech, Carnegie Mellon, Colorado, Cornell, Fairfield, Fermilab, Florida, Florida International, Florida State, Florida Tech, Illinois/Chicago, Iowa, Iowa State, Johns Hopkins, Kansas, Kansas State, LLNL, Maryland, Minnesota, Mississippi, MIT, Nebraska/Lincoln, Northeastern, Northwestern, Notre Dame, Ohio State, Princeton, Puerto Rico, Purdue, Purdue/Calumet, Rice, Rochester, Rockefeller, Rutgers, SUNY/Buffalo, Tennessee, Texas A&M, Texas Tech, Vanderbilt, Virginia, VPI, Wisconsin
--------	-----------------------	---

Particle Astrophysics

Auger	Watson	Aachen, Adelaide, Alcala de Henares, Arcetri, Bahia, Bariloche, Bonn, Bolivia, UCLA, Campinas, Case Western Reserve, Catania, CBPF, Charles, Chicago, CINVESTAV, Colorado, Colorado State, Columbia, Dwingello, Fermilab, Fluminense, FZU/Czech Republic, Gran Sasso, Grenoble, Groningen, Hanoi, IFAE/Argentina, IEKP/Karlsruhe, IK/Karlsruhe, INFN/Italy, INP/Poland, IPE/Karlsruhe, IPN/Orsay, LAL/Orsay, La Plata, L'Aquila, Lecce, Leeds, LIP/Portugal, Lodz, Louisiana State, LPNHE, Madrid, Michigan Tech, Milano, Minnesota, Napoli, Nebraska, New Mexico, NIKHEF, Northeastern, Nova Gorica, Ohio State, Oxford, Paris VII, Penn State, Puebla, Radboud, Roma II, San Andres, San Nicolas de Hidalgo, Santana-Bahia, Santiago de Compostela, São Paulo, Siegen, Southern, Suboeste Bahia, Tandar, Torino, UFRJ, UNAM, Utah, UTM Mendoza and San Rafael, Wisconsin/Milwaukee, Wuppertal
SDSS	Weinberg	Amer. Mus. Nat. History, Astrophys. Inst. Potsdam, Basel, Cambridge, Case Western Reserve, Chicago, Drexel, Fermilab, Inst. for Adv. Study, Japan Participation Group, Johns Hopkins, Joint Inst. Nucl. Astrophys. (Mich. State/Notre Dame/Chicago), Kavli Inst. (SLAC/Stanford), Korean Scientist Group, LAMOST, LANL, Max Planck/Garching, Max Planck/Heidelberg, New Mexico State, Ohio State, Pittsburgh, Portsmouth, Princeton, US Naval Observatory, Washington
CDMS	Sadoulet / Cabrera	Brown, UC/Berkeley, UC/Santa Barbara, Case Western Reserve, Colorado/Denver, Fermilab, Florida, LBNL, Minnesota, NIST/Boulder, Santa Clara, Stanford
DES / DECam	Peoples / Annis / Flaughner	ANL, Brazil DES Consortium of Scientists, Chicago, CTIO, Fermilab, Illinois, LBNL, Michigan, Ohio State, Pennsylvania, Spain DES Collaboration (IEEC, IFAE, CIEMAT), United Kingdom DES Collaboration (Cambridge, Edinburgh, Portsmouth, Sussex), Univ. Coll. London
COUPP	Collar	Chicago, Fermilab, Indiana
Scientific Simulations		
Lattice QCD	Sugar	ANL, Arizona, Baylor, Boston, BNL, UC/Davis, UC/San Diego, UC/Santa Barbara, Carnegie Mellon, Colorado, Columbia, Cornell, Duke, Fermilab, Florida State, George Washington, Illinois, Indiana, JLab, Kentucky, LANL, MIT, Ohio State, Pacific, Pittsburgh, Utah, Virginia, Washington, Washington/St. Louis
Accelerator Modeling (COMPASS)	Spentzouris	ANL, BNL, UC/Davis, UCLA, Fermilab, JLab, LANL, LBNL, Maryland, ORNL, SLAC, USC, Stony Brook, Tech-X Corp

Figure 15. Significant Fermilab activities other than the major approved particle physics experiments using the Fermilab accelerator complex.

SECTION VI. SUMMARIES OF APPROVED EXPERIMENTS

Summaries are given in this Section of major approved experiments which have not yet completed data-taking, and also those major experiments still carrying out a significant analysis effort. Most were prepared recently by the experiment spokesperson(s).

This section also includes summaries of significant experimental physics activities in which Fermilab physicists are involved, but which are not particle physics experiments at Fermilab accelerators. (Note that in the user/institution statistics, only the Fermilab physicists on these activities are included.)

Statistics on Fermilab users are given in Table 5, together with information on how they are derived.

TABLE 5. DATA ON FERMILAB USERS

The data given below are based on the following:

1. Data on Fermilab users are updated annually, generally about February of each year.
2. Fermilab experiments included in the list are those approved by the Laboratory, and in any of the stages from approval to data analysis, as given in the Experimental Program Situation Report on pages 30-31. The experiment personnel is supplied by the experiment spokespersons, and is divided into physicists or graduate students; it includes Fermilab physicists on the experiments. Also included are Fermilab physicists who are involved in significant experimental physics activities which are not particle physics experiments at Fermilab accelerators and are listed in the Situation Report; this includes such activities as collaboration on astrophysics experiments and on the CMS experiment at the CERN LHC.
3. Although a user or an institution may be involved in more than one experiment, he/she/it is only counted once in any totals.
4. When experiments pass into the data analysis stage, students may graduate and move to other experiments and/or institutions, as also may more senior researchers. For experiments in the data analysis stage, we list users and institutions as at the end of the data-taking phase.

	<u>Physicists</u>	<u>Students</u>	<u>Subtotal</u>	<u>Institutions</u>
<u>US</u>				
University	642	304	946	97
Industry	0	0	0	0
National Lab.	380	4	384	7
Subtotal	1022	308	1330	104
<u>Non-US</u>				
University	465	257	722	104
Industry	0	0	0	0
National Lab.	184	44	228	21
Subtotal	649	301	950	125
Total	1671	609	2280	229

Selex (E781) Proton Center Layout

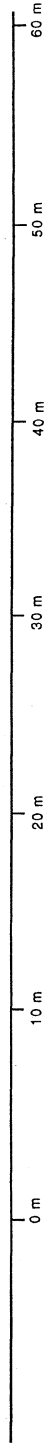
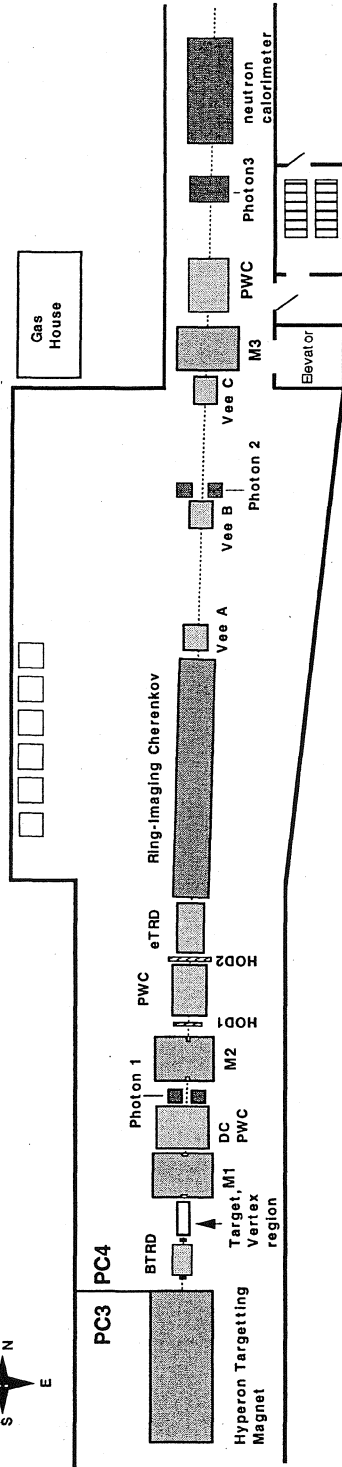

Vertex Region

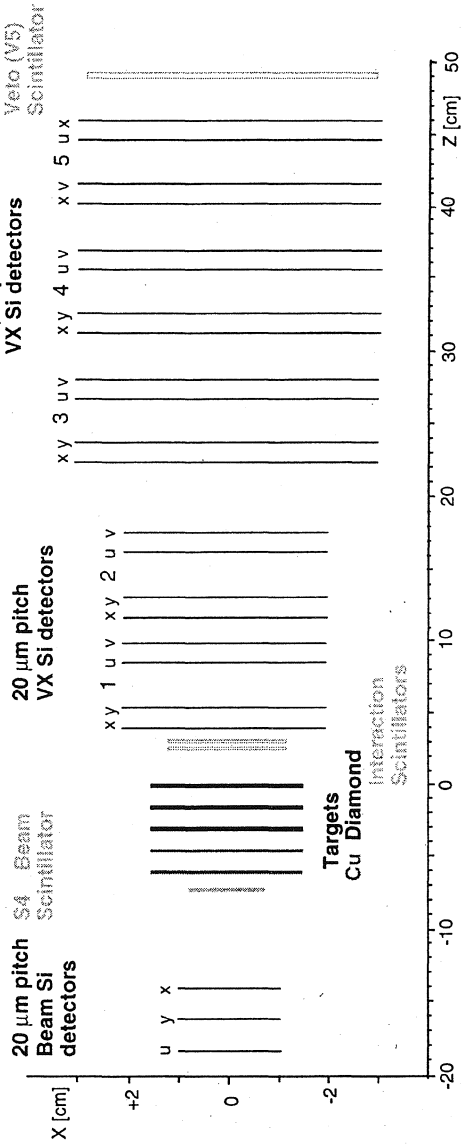

E-781 (Russ) Study of Charm Baryon Physics

Bogazici (Turkey), Bristol (United Kingdom), Carnegie Mellon, CBPF (Brazil), Fermilab, Hawaii, IHEP/Beijing (China), IHEP/Protvino (Russia), Iowa, ITEP (Russia), Moscow State (Russia), MPI/Heidelberg (Germany), Paraiba (Brazil), PNPI (Russia), Rochester, INFN/Rome (Italy), Rome (Italy), San Luis Potosi (Mexico), São Paulo (Brazil), Tel Aviv (Israel), INFN/Trieste (Italy), Trieste (Italy)

Status: *Data Analysis*

The Fermilab fixed-target program has long been concerned with understanding the physics of charm hadron production and decays. The aim of E-781 (SELEX) was to complement previous or contemporaneous work in hadroproduction and photoproduction by emphasizing physics at large Feynman- x , where the charm hadron carries off a large fraction of the incident beam momentum. Most charm hadroproduction experiments have used only pion beams and worked near $x_F = 0$, where production of all types of secondary particles is maximal. Charm mesons are by far the dominant charm species in these experiments. Empirical observations of the strange hyperons indicate that the baryon/meson ratio increases at large x_F . E-781 is unique in its ability to see whether this feature of hadroproduction also holds true for heavy quark systems like charm. There are also important features of charm hadroproduction that may depend on the incident beam particle. E-781, using different beam hadrons from the Fermilab hyperon beam, is the only experiment that can address these issues.

E-781 employed a novel impact-parameter software trigger to select charm candidates for writing to tape. Charm particles have a short but finite decay length. A high-resolution vertex detector close to the production point can select charm candidates based on the miss-distance of the decay tracks evaluated at the primary production vertex. E-781 built a 50,000 strip silicon vertex detector system to reconstruct on-line all high-momentum (>15 GeV/c) tracks from each interaction with 6 micron resolution. Events were recorded on tape only when the reconstruction indicated that these tracks did NOT come from a single primary vertex. The goal was to take a large data set with a loose hardware trigger but to avoid huge software overheads in extracting physics. The full spectrometer, shown in the accompanying figure, includes a two-stage magnetic spectrometer and excellent particle identification information from the downstream Ring-Imaging Cerenkov Counter. This is especially important for identifying charm baryon decays in the large x_F region.

Physics questions for charm studies have to do both with production and decay mechanisms. In charm baryon decays, the charm quark may decay or interact through exchange mechanisms with the light quarks. Unlike meson decays, there is no helicity suppression for exchanges, and a rich spectrum of quasi-two-body decay modes may occur. Do they? There is little experimental information on the question. Such a study requires good charged-particle identification and good photon detection. Comparison of non-leptonic and semi-

leptonic decays is also important. E-781 has good photon coverage, electron tagging and fast charged-particle identification. We expect to make new studies of the higher-order corrections to the charm decay mechanisms explored by combining Heavy Quark Effective Theory and perturbative QCD.

Strong interaction physics can be studied in the production of charm hadrons. Strange hyperons show intriguing polarization effects in strong production. What happens for charm baryons? E-781 expects to measure polarizations. There are open questions about possible direct charm content of non-charmed mesons and nucleons, as well as color-drag effects in production at large x_F . Such studies demand comparisons between different beam hadrons and also good acceptance at large x_F . E-781 is designed to make these studies and has presented preliminary reports of systematic behavior of this type.

The physics potential of the experiment touches many little-known areas of heavy quark physics. The focus on charm baryons is especially appropriate for a hadron machine. The experiment recorded events from 15 billion inelastic collisions during the 1996-97 fixed-target period. We developed a run-time Data Summary Tape (DST) strategy for the first-level processing pass, akin to the skimming pass of the Tevatron Collider experiments. We identified interesting events during initial track reconstruction and wrote out condensed records having only physics information and identifiers for those events. Sample charm mass plots from this condensed output file can be seen in the figure. This has worked well. Initial physics results have been presented at conferences and have been submitted to journals. Topics range from total cross section measurements to precision charm hadron lifetimes to new features of charm hadroproduction.

E-781 analysis continues. In 2002 we reported the first observation of Double-Charm baryons. This exciting result was part of the original experimental proposal. We extracted the small, clean sample of events using the standard E-781 analysis tools that were developed for single-charm studies. Subsequently two independent E-781 analyses have confirmed the effect in our data. We have continued to study other decay modes and have published the observation of a new decay mode of the original state. In addition, we have reported the observation of an intriguing new spectroscopy in the double-charm system at conferences. In single-charm baryon physics, we have the world's largest sample of Ω_c baryons and are preparing papers on the production mechanism and a lifetime measurement from these data. The lifetime paper has just been submitted for publication, using data from two decay modes of the Ω_c . We have published the first observation of an unusual charm-strange meson at 2632 MeV. This state is not seen in photoproduction. This fact, combined with its large relative branching ratio to $D_s^+ \eta$, has prompted theoretical speculation that it may be a 4-quark state. We have a number of new papers in preparation for publication in 2007. Exciting new physics continues to emerge from E-781.

Publications

The SELEX Phototube RICH Detector, J. Engelfried et al., Nucl. Instr. and Meth. A431, 53 (1999).

Observation of the Cabibbo Suppressed Decay $\Xi_c^+ \rightarrow pK^-\pi^+$, S. Y. Jun et al., Phys. Rev Lett. 84, 1857 (2000).

Total Cross-Section Measurements with π^- , Σ^- and Protons on Nuclei and Nucleons Around 600 GeV/c, U. Dersch et al., Nucl. Phys. B579, 277 (2000).

Radiative Decay Width of the $A(2)(1320)$ -Meson, V. V. Molchanov et al., Phys. Lett. B521, 171 (2001).

Measurement of the Σ^- Charge Radius by Σ^- Electron Elastic Scattering, I. Eschrich et al., Phys. Lett. B522, 233 (2001).

Measurement of the D_s^+ Lifetime, M. Iori et al., Phys. Lett. B523, 22 (2001).

Precision Measurements of the Λ_c^+ and D^0 Lifetimes, A. Kushnirenko et al., Phys. Rev. Lett. 86, 5243 (2001).

First Observation of the Doubly Charmed Baryon Ξ_{cc}^+ , M. Mattson et al., Phys. Rev. Lett. 89, 112001 (2002).

Hadronic Production of Λ_c from 600 GeV/c π^- , Σ^- and p Beams, F. G. Garcia et al., Phys. Lett. B528, 49 (2002).

First Measurement of $\pi^-e \rightarrow \pi^-e\gamma$ Pion Virtual Compton Scattering, A. Ocherashvili et al., Phys. Rev. C66, 034613 (2002).

Production Asymmetry of D_s from 600 GeV/c Σ^- and π^- Beams, M. Kaya et al., Phys. Lett. B558, 34 (2003).

First Observation of a Narrow Charm-Strange Meson $D_{sJ}^+(2632) \rightarrow D_s^+\eta$ and D^0K^+ , A. V. Evdokimov et al., Phys. Rev. Lett. 93, 242001 (2004).

Upper Limit on the Decay $\Sigma^-(1385) \rightarrow \Sigma^-\gamma$ and Cross Section for $\gamma\Sigma^- \rightarrow \Lambda\pi^-$, V. V. Molchanov et al., Phys. Lett. B590, 161 (2004).

Polarization of Σ^+ Hyperons Produced by 800 GeV/c Protons on Cu and Be, P. Pogodin et al., Phys. Rev. D70, 112005 (2004).

The Lead-Glass Electromagnetic Calorimeter for the SELEX experiment, M. Y. Balatz et al., Nucl. Instr. and Meth. A545, 114 (2005).

Confirmation of the Double Charm Baryon $\Xi_{cc}^+(3520)$ Via Its Decay to pD^+K^- , A. Ocherashvili et al., Phys. Lett. B628, 18 (2005).

Theses

U. Dersch, Max Planck Institute für Kernphysik, Germany

I. Eschrich, Max Planck Institute für Kernphysik, Germany

F. Garcia, Univ. of São Paulo, Brazil

M. Kaya, Univ. of Iowa

H. Kruger, Max Planck Institute für Kernphysik, Germany

A. Kushnirenko, Carnegie Mellon Univ.

P. Mathew, Carnegie Mellon Univ.

K. Nelson, Univ. of Iowa

A. Ocherashvili, Tel Aviv Univ., Israel

P. Pogodin, Univ. of Iowa

J. Simon, Max Planck Institute für Kernphysik, Germany

K. Vorwalter, Max Planck Institute für Kernphysik, Germany

M. Srivastava, Univ. of São Paulo

M. Mattson, Carnegie Mellon University

U. Akgun, Univ. of Iowa

A. S. Ayan, Univ. of Iowa

KTeV Spectrometer

(PLAN VIEW)

ANALYSIS MAGNET

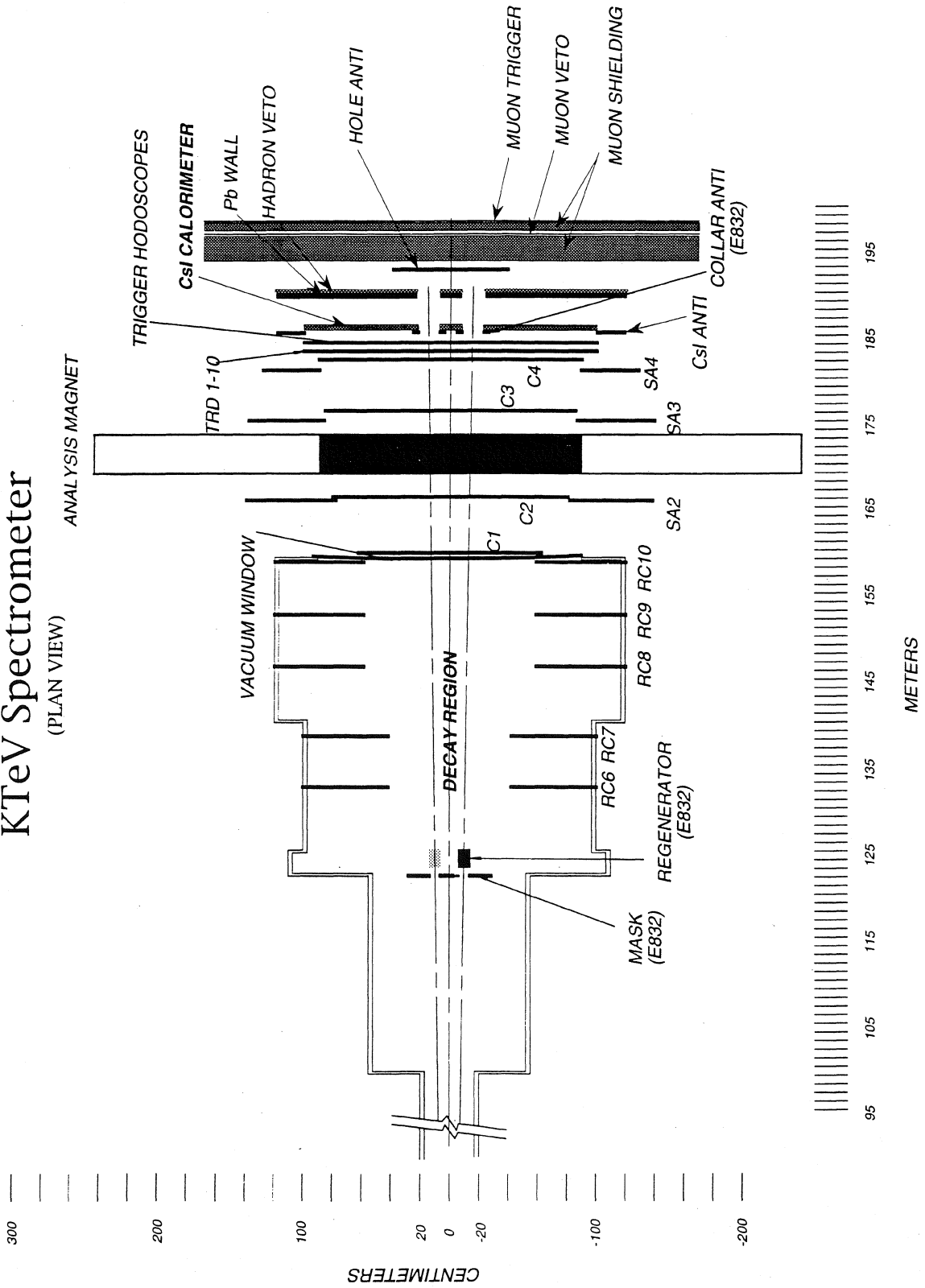

E-799 (Tschirhart) / E-832 (Blucher) Rare Decays of K_L^0 and a Search for Direct CP Violation in $K_L^0 \rightarrow 2\pi$

Arizona, UCLA, UC/San Diego, Campinas (Brazil), Chicago, Colorado, Elmhurst, Fermilab, Osaka (Japan), Rice, Rutgers, Sao Paulo (Brazil), Virginia, Wisconsin

Status: *Data Analysis*

KTeV (Kaons at the Tevatron) consists of two experiments: E-799II and E-832. E-799 is an experiment to search for rare K_L decays, such as $K_L \rightarrow \pi^0 l^+ l^-$ ($l = e, \mu, \nu$), and many other multibody rare decays, to a sensitivity of 10^{-10} , an order of magnitude improvement over previous searches. The goal of E-832 is a measurement of the direct CP violation parameter $\text{Re}(\epsilon'/\epsilon)$ with a precision of 1×10^{-4} , a factor of six improvement over previous experiments at FNAL (E-731) and CERN (NA31).

To achieve the required level of statistical and systematic uncertainty in ϵ'/ϵ , KTeV (E-832) used the same double-beam technique as E-731 with a new detector and beamline. Following the primary target, collimators and sweeping magnets are used to form two almost parallel neutral beams. A fully active regenerator is placed in one of the beams 122m from the production target, at the upstream end of the decay region, to provide a source of K_S for the experiment. The regenerator is moved from one beam to the other each minute to eliminate many possible systematic errors in normalization and detector response. All four $K \rightarrow \pi\pi$ decays are detected simultaneously. The detector consists of a large vacuum decay region instrumented with photon veto counters, a drift chamber spectrometer, a pure CsI electromagnetic calorimeter, and a large hodoscope behind 4m of steel for muon detection. Compared to E-731, KTeV also has an improved trigger and data acquisition system. The final stage of the trigger includes full event reconstruction and filtering before data are written to tape. For E-799 data collection, the regenerator is not used, and an extensive TRD system is moved into the beam upstream of the CsI calorimeter.

The experiment first took about 10 months of data divided between E-799 and E-832 during the 1996-97 fixed-target run. After some detector modifications to improve systematic data quality and data-taking efficiency, KTeV collected data again in the 1999 fixed-target run. The 1999 run doubled the E-832 data sample from 1996-97 and almost tripled the E-799 data sample. The full data sample (1996+1997+1999) will allow E-832 to reduce the statistical error on ϵ'/ϵ to 1×10^{-4} . The combined (1997+1999) E-799 rare decay data set corresponds to a flux of about 6×10^{11} K_L decays and a large number of cascade (hyperon) decays. This rich data set together with high precision electromagnetic calorimetry and excellent particle ID (TRD system) provides access to rare kaon decay sensitivities in the 10^{-10} range.

KTeV has published 39 papers based on the data samples collected from both the 1996-97 and 1999 runs. These papers are listed below.

In 1999, the first ε'/ε result based on 1/4 of the 1996-1997 E-832 data sample (1/8 of the full KTeV data sample) was announced, definitively establishing the existence of direct CP violation. In June 2001, KTeV presented an improved measurement of ε'/ε based on the 1996-1997 data sample: $\text{Re}(\varepsilon'/\varepsilon) = (20.7 \pm 2.8) \times 10^{-4}$. This analysis also included precise measurements of the K_S lifetime, the K_S - K_L mass difference, and the relative phases of the CP-violating and CP-conserving amplitudes; most of these measurements represent significant improvements over the best previous experiments. A long article describing this work was published in Physical Review D. Another notable result based on the 1996-1997 E-832 data sample is a precise measurement of the semileptonic charge asymmetry (δ_l) using about 300 million $K_L \rightarrow \pi \nu$ events. In 2004 the E-832 experiment reported a new measurement of the CKM matrix element $|V_{us}|$ based on precision measurement of the six major K_L branching fractions and form factors. This new measurement resolved a long-standing tension in the unitarity sum of the first row of the CKM matrix. Analysis of the full E-832 data sample (1996+1997+1999) is progressing, and as mentioned above, the full data sample will allow E-832 to reduce the statistical error on ε'/ε to 1×10^{-4} ; significant work will be required to reduce the systematic error to a similar level.

The KTeV experiment E-799 Phase II is a continuation of the rare kaon decay search experiment E-799. The first phase of E-799 ran using an upgraded E-731 detector between October 1991 and January 1992, in the Meson Center beamline. Published results from the first phase of E-799 are listed below:

<u>Decay Mode</u>	<u>E-799I BR results</u>	<u>Paper</u>
$\pi^0 \rightarrow ee$	$(7.6^{+3.9}_{-2.8} \pm 0.5) \times 10^{-8}$	PRL <u>71</u> , 34 (1993)
$K_L \rightarrow \pi^0 ee$	$< 4.3) \times 10^{-9}$	PRL <u>71</u> , 3918 (1993)
$K_L \rightarrow \pi^0 \mu\mu$	$< 5.1) \times 10^{-9}$	PRL <u>71</u> , 3914 (1993)
$\pi^0 \rightarrow \mu e$	$< 8.6) \times 10^{-9}$	PL <u>B320</u> , 407 (1994)
$K_L \rightarrow eeee$	$(3.96 \pm 0.78 \pm 0.32) \times 10^{-8}$	PRL <u>72</u> , 3000 (1994)
$K_L \rightarrow \pi^0 \nu \bar{\nu}$	$< 5.8) \times 10^{-5}$	PRL <u>72</u> , 3758 (1994)
$K_L \rightarrow \pi^0 \pi^0 \gamma$	$< 2.3) \times 10^{-4}$	PR <u>D50</u> , 1874 (1994)
$K_L \rightarrow ee \gamma \gamma$	$(6.5 \pm 1.2 \pm 0.6) \times 10^{-7}$	PRL <u>73</u> , 2169 (1994)
$\Lambda, \bar{\Lambda}$ polarization		PL <u>B338</u> , 403 (1994)
$K_L \rightarrow \mu\mu\gamma$	$(3.23 \pm 0.23 \pm 0.19) \times 10^{-7}$	PRL <u>74</u> , 3323 (1995)
$K_L \rightarrow ee\mu\mu$	$(2.9^{+6.7}_{-2.4}) \times 10^{-9}$	PRL <u>76</u> , 4312 (1996)
$K_L \rightarrow \pi^0 \mu e$	$< 3.2) \times 10^{-9}$	PL <u>B432</u> , 30 (1998).

Using the KTeV detector, E-799 Phase II has dramatically improved on these Phase I results, typically by a factor of 50 in sensitivity, and a number of new phenomena have been observed. The main goal of E-799II was to improve the sensitivity of the searches for the $K_L \rightarrow \pi^0 1^+ 1^-$ decay modes, which have

partial widths closely related in the Standard Model to ε'/ε . Results for $K_L \rightarrow \pi^0 e^+ e^-$ have now been published for the entire E-799II data set, and results for $K_L \rightarrow \pi^0 \mu^+ \mu^-$ from the full data set will be published in 2005. Another exciting result from E-799II has been the observation of a very large CP-violating angular asymmetry in the decay $K_L \rightarrow \pi^+ \pi^- e^+ e^-$. This asymmetry, in the angle between the hadronic and leptonic planes, was predicted in 1992, and E-799II has measured it to be approximately 14% after correcting for acceptance (which actually makes the raw observed asymmetry larger, at about 23%). The asymmetry is caused by interference between CP-violating and CP-conserving amplitudes which happen to be of comparable size for this mode. The asymmetry is also odd under time reversal, but is not necessarily T-violating, because of the existence of both absorptive and dispersive amplitudes for this process.

Publications

Search for Light Gluinos Via the Spontaneous Appearance of $\pi^+ \pi^-$ Pairs with an 800 GeV/c Proton Beam at Fermilab, J. Adams et al., Phys. Rev. Lett. 79, 4083 (1997).

Measurement of the Branching Fraction of the Decay $K_L \rightarrow \pi^+ \pi^- e^+ e^-$, J. Adams et al., Phys. Rev. Lett. 80, 4123 (1998)

Search for the Decay $K_L \rightarrow \pi^0 \nu \bar{\nu}$, J. Adams et al., Phys. Lett. B447, 240 (1999).

Observation of $\Xi^0 \rightarrow \Sigma^+ e^- \bar{\nu}$, A. Affolder et al., Phys. Rev. Lett. 82, 3751 (1999).

Observation of Direct CP Violation in $K_S, K_L \rightarrow \pi \pi$ Decays, A. Alavi-Harati et al., Phys. Rev. Lett. 83, 22 (1999).

Measurement of the Decay $K_L \rightarrow \pi^0 \gamma \gamma$, A. Alavi-Harati et al., Phys. Rev. Lett. 83, 917 (1999).

Measurement of the Branching Ratio of $\pi^0 \rightarrow e^+ e^-$ Using $K_L \rightarrow 3\pi^0$ Decays in Flight, A. Alavi-Harati et al., Phys. Rev. Lett. 83, 922 (1999).

Light Gluino Search for Decays Containing $\pi^+ \pi^-$ or $\pi^0 \pi^0$ from a Neutral Hadron Beam at Fermilab, A. Alavi-Harati et al., Phys. Rev. Lett. 83, 2128 (1999).

Observation of CP Violation in $K_L \rightarrow \pi^+ \pi^- e^+ e^-$ Decays, A. Alavi-Harati et al., Phys. Rev. Lett. 84, 408 (2000).

Search for the Decay $K_L \rightarrow \pi^0 \nu \bar{\nu}$ Using $\pi^0 \rightarrow e^+ e^- \gamma$, A. Alavi-Harati et al., Phys. Rev. D61, 72006 (2000).

Search for the Weak Decay of a Lightly Bound H^0 Dibaryon, A. Alavi-Harati et al., Phys. Rev. Lett. 84, 2593 (2000).

Observation of the Decay $K_L \rightarrow \mu^+ \mu^- \gamma \gamma$, A. Alavi-Harati et al., Phys. Rev. D62, 112001 (2000).

Search for the Decay $K_L \rightarrow \pi^0 \mu^+ \mu^-$, A. Alavi-Harati et al., Phys. Rev. Lett. 84, 5279 (2000).

Study of the Decay $K_L \rightarrow \pi^+ \pi^- \gamma$, A. Alavi-Harati et al., Phys. Rev. Lett. 86, 761 (2001).

Search for the Decay $K_L \rightarrow \pi^0 e^+ e^-$, A. Alavi-Harati et al., Phys. Rev. Lett. 86, 397 (2001).

A Measurement of the Branching Ratio of $K_L \rightarrow e^+ e^- \gamma \gamma$, A. Alavi-Harati et al., Phys. Rev. D64, 012003 (2001).

First Observation of the Decay $K_L \rightarrow \pi^0 e^+ e^- \gamma$, A. Alavi-Harati et al., Phys. Rev. Lett. 87, 021801 (2001).

A Measurement of the Branching Ratio and Asymmetry of the Decay $\Xi^0 \rightarrow \Sigma^0 \gamma$, A. Alavi-Harati et al., Phys. Rev. Lett. 86, 3239 (2001).

Measurements of the Rare Decay $K_L \rightarrow e^+e^-e^+e^-$, A. Alavi-Harati et al., Phys. Rev. Lett. 86, 5425 (2001).

First Measurement of Form-Factors of the Decay $\Xi^0 \rightarrow \Sigma^+e^-\bar{\nu}_e$, A. Alavi-Harati et al. Phys. Rev. Lett. 87, 132001 (2001).

A New Measurement of the Radiative Ke3 Branching Ratio and Photon Spectrum, A. Alavi-Harati et al., Phys. Rev. D64, 112004 (2001).

Branching Ratio Measurement of the Decay $K_L \rightarrow e^+e^-\mu^+\mu^-$, A. Alavi-Harati et al., Phys. Rev. Lett. 87, 111802 (2001).

Measurement of the Branching Ratio and Form Factor of $K_L \rightarrow \mu^+\mu^-\gamma$, A. Alavi-Harati et al., Phys. Rev. Lett. 87, 071801 (2001).

Radiative Decay Width Measurements of Neutral Kaon Excitations Using the Primakoff Effect, A. Alavi-Harati et al., Phys. Rev. Lett. 89, 072001 (2002).

A Measurement of the K_L Charge Asymmetry, A. Alavi-Harati et al., Phys. Rev. Lett. 88, 181601 (2002).

Search for the $K_L \rightarrow \pi^0\pi^0e^+e^-$ Decay in the KTeV Experiment, A. Alavi-Harati et al., Phys. Rev. Lett. 89, 211801 (2002).

Measurements of Direct CP Violation, CPT Symmetry, and Other Parameters in the Neutral Kaon System, A. Alavi-Harati et al., Phys. Rev. D67, 012005, (2003).

Measurements of the Decay $K_L \rightarrow e^+e^-\mu^+\mu^-$, A. Alavi-Harati et al., Phys. Rev. Lett. 90, 141801 (2003).

Search for the Rare Decay $K_L \rightarrow \pi^0e^+e^-$, A. Alavi-Harati et al., Phys. Rev. Lett. 93, 021805 (2004).

A Determination of the CKM Parameter $|V_{us}|$, T. Alexopoulos et al., Phys. Rev. Lett. 93, 181802 (2004).

Measurements of K_L Branching Fractions and the CP Violation Parameter $|\eta_{+-}|$, T. Alexopoulos et al., Phys. Rev. D70, 092006 (2004).

Measurements of Semileptonic K_L Decay Form Factors, T. Alexopoulos et al., Phys. Rev. D70, 092007 (2004).

Measurements of the Branching Fractions and Decay Distributions for $K_L \rightarrow \pi\mu\nu\gamma$ and $K_L \rightarrow \pi e\nu\gamma$, T. Alexopoulos et al., Phys. Rev. D71, 012001 (2005).

Observation of the Decay $\Xi^0 \rightarrow \Sigma^+\mu^-\bar{\nu}_\mu$, E. Abouzaid et al., Phys. Rev. Lett. 95, 081801 (2005).

A Measurement of the K^0 Charge Radius and a CP Violating Asymmetry Together with a Search for CP Violating E1 Direct Photon Emission in the Rare Decay $K_L \rightarrow \pi^+\pi^-e^+e^-$, E. Abouzaid et al., Phys. Rev. Lett. 96, 101801 (2006).

Measurement of Direct Emission in the $K_L \rightarrow \pi^+\pi^-\gamma$ Decay Mode, E. Abouzaid et al., Phys. Rev. D74, 032004 (2006).

Improved $K_L \rightarrow \pi e\nu$ Form Factor and Phase Space Integral with Reduced Model Uncertainty, E. Abouzaid et al., Phys Rev. D74, 097101 (2006).

Measurement of the Rare Decay $\pi^0 \rightarrow e^+e^-$, E. Abouzaid et al., Phys Rev. D75, 012004 (2007).

Ξ^0 and anti- Ξ^0 Polarization Measurement at 800 GeV/c, E. Abouzaid et al., Phys Rev D75, 012005 (2007).

E-823

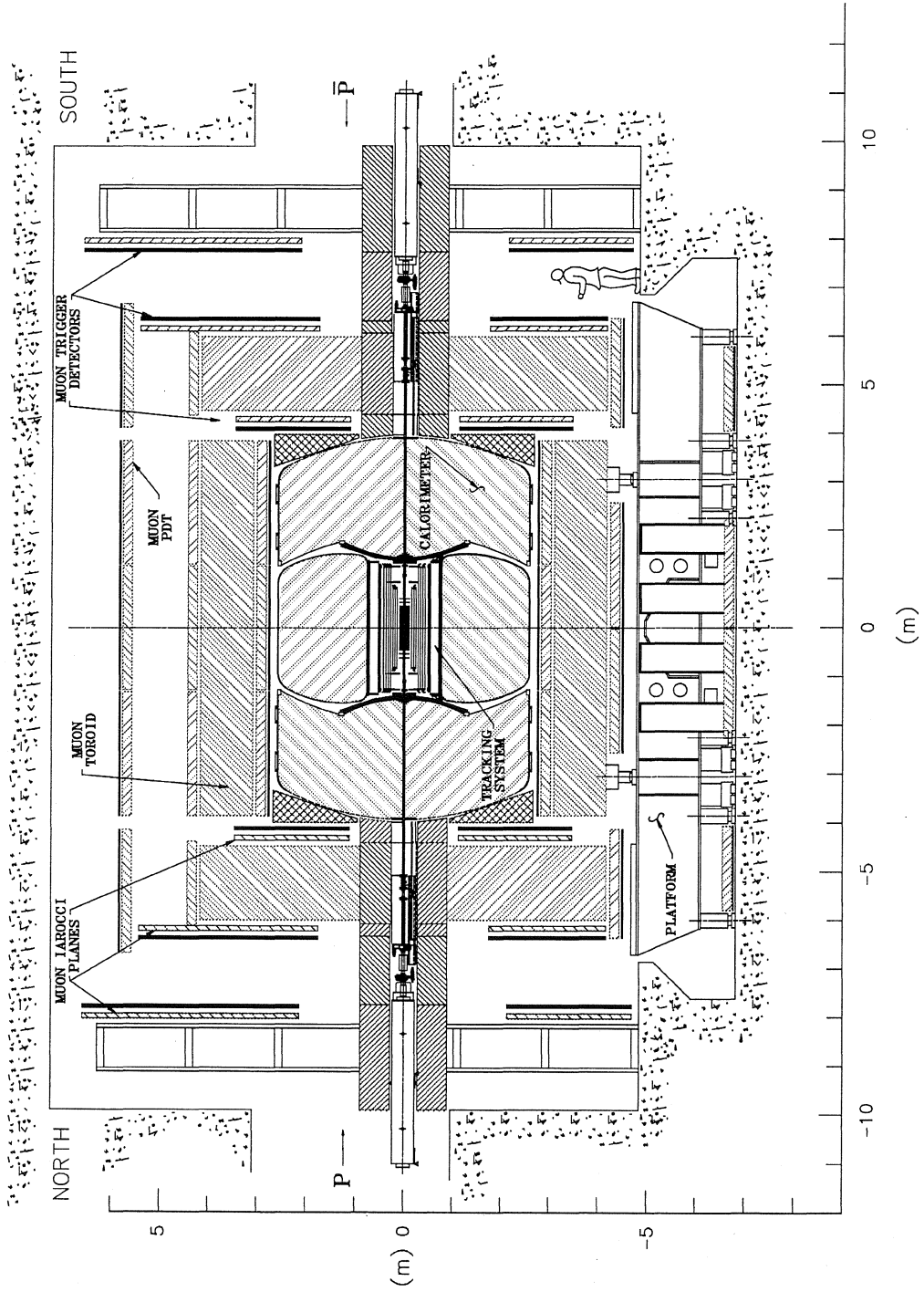

Side view of the DØ detector for Run II

E-823 / 900 / 908 / 925 (Denisov / Wyatt) Study of Events in $\bar{p}p$ Collisions at 2 TeV in the D0 Detector

Aachen (Germany), Acad. Sci. (Czech Rep.), Alberta (Canada), los Andes (Colombia), Arizona, BNL, Bonn (Germany), Boston, Brown, Buenos Aires (Argentina), UC/Riverside, CBPF (Brazil), Charles (Czech Rep.), CINVESTAV (Mexico), Clermont-Ferrand (France), Columbia, CSU/Fresno, Czech Tech (Czech Rep.), Delhi (India), University College Dublin (Ireland), Estadual Paulista (Brazil), Fermilab, Florida State, Freiburg (Germany), Grenoble (France), IHEP/Protvino (Russia), Illinois/Chicago, Imperial College (United Kingdom), Indiana, Iowa State, ITEP (Russia), JINR (Russia), Kansas, Kansas State, Korea (Korea), Lancaster (United Kingdom), Langston, LBNL and UC/Berkeley, LMU Munich (Germany), Louisiana Tech, Lyon (France), Mainz (Germany), Manchester (United Kingdom), Marseille (France), Maryland, McGill (Canada), Michigan, Michigan State, Mississippi, Moscow State (Russia), Nebraska, Nijmegen / NIKHEF (Netherlands), NIKHEF/Amsterdam (Netherlands), Northeastern, Northern Illinois, Northwestern, Notre Dame, Oklahoma, Oklahoma State, Orsay (France), Panjab (India), Paris VI and VII (France), PNPI (Russia), Princeton, Purdue/Calumet, Rice, Rio de Janeiro (Brazil), Rochester, Saclay (France), San Francisco de Quito (Ecuador), Simon Fraser (Canada), Southern Methodist, Strasbourg (France), Sung Kyun Kwan (Korea), SUNY/Buffalo, SUNY/Stony Brook, Swedish Consortium (Sweden), Tata (India), Texas/Arlington, USTC (China), Virginia, Washington, Wuppertal (Germany), York (Canada)

Status: *E-823 - Data-Taking
E-900 - Data Analysis
E-908 - Data-Taking
E-925 - Data-Taking*

The D0 detector is a large, hermetic, 4π detector at Fermilab designed for the study of proton-antiproton collisions with a center-of-mass energy of 2.0 TeV. The detector stresses identification of leptons, photons, jets, and missing transverse energy for high- p_T physics. D0 is an international collaboration representing the efforts of over 675 physicists and Ph.D. students from over 80 institutions whose goal is to study a diverse range of particle physics topics. The Run I D0 experiment (E-740) successfully completed data-taking in 1996, collecting $\sim 120 \text{ pb}^{-1}$ of data at $\sqrt{s} = 1.80 \text{ TeV}$, including a small fraction at 0.63 TeV. The Run IIa D0 experiment (E-823) achieved a major milestone in 2006 by recording more than 1 fb^{-1} of data at 1.96 TeV. The Run IIb upgraded D0 experiment (E-925) started data taking in June 2006.

The D0 Run II detector (E-823) has been completed and represents a major upgrade of the Run I detector. The detector has been designed to operate at instantaneous luminosities near $2 \times 10^{32} \text{ cm}^{-2} \text{ s}^{-1}$ with bunch spacings as short as 132 ns. To meet the challenges of such a high-rate environment, the entire central tracking system has been replaced with a silicon microvertex detector, a scintillating-fiber tracker, a solenoid magnet, and central and forward preshower detectors. The new tracking detectors have enhanced pattern recognition and triggering opportunities for lepton, photon and jet final states. The entire Run II physics menu has been significantly enhanced by the new detectors.

The silicon micro-vertex detector (SMT) consists of 792,000 channels and subtends an active area of 4.7 m². It provides precise tracking in the region $|\eta| < 3$. The silicon tracker consists of silicon disks and barrels formed into six disk/barrel modules. Each barrel module consists of four (radial) layers of detector ladder assemblies which provide coverage for large angle tracks. Three-dimensional reconstruction of tracks at forward rapidities is performed using the disks. The SMT was constructed at the Fermilab Silicon Detector Facility and installed in D0 in late 2000.

The central scintillating-fiber tracker (CFT), an innovative design based on visible light photon counters (VLPC), is in operation. The fiber tracker consists of 72,000 835-micron fibers arranged into eight radial layers. It provides an off-line momentum measurement for charged particles with $|\eta| < 2$ and fast trigger information for tracks with $|\eta| < 1.6$. The single-channel noise rate, quantum efficiency and photo-electron yield all meet design specifications. Combining fiber and silicon tracker information provides a charged-particle momentum measurement with a resolution of $\Delta p/p = 2\%$ at $p_T = 1$ GeV/c degrading to 10-18% for 100 GeV/c tracks. The superconducting solenoid magnet has been successfully installed and currently operates at a field of 1.9T.

Sandwiched between the solenoid and central calorimeter is the central preshower detector (CPS) which was installed simultaneously with the solenoid. The central preshower consists of 7280 channels of 6.6 mm scintillating triangular fibers and enables efficient triggering on electrons and photons in a high-rate environment.

The tracking detectors are surrounded by a hermetic liquid argon sampling calorimeter with uranium and copper/steel absorbers. The calorimeter is contained in three cryostats (a central barrel and two endcaps). The calorimeter is nearly compensating and finely segmented to identify electrons, photons, and jets. The electromagnetic (EM) calorimeter covers $|\eta| < 3$ and hadronic calorimetry extends to $|\eta| < 4.4$; the large acceptance provides excellent measurement of the missing transverse energy. The segmentation in $\Delta\eta \times \Delta\phi = 0.1 \times 0.1$ (0.05×0.05 at EM shower maximum); the energy resolution is $\sim 15\%/\sqrt{E}$ for electrons and photons (with a small constant term) and $\sim 85\%/\sqrt{E}$ for jets. The calorimeter readout electronics has been upgraded to a switched capacitor array design and the shaping times have been re-optimized to cope with shorter beam crossing. The calorimeter is in stable operation.

Outside the calorimeter cryostats is the upgraded muon tracking system. An independent measurement of the muon momentum is performed in the magnetized iron toroids using planes of mini-drift tubes in the forward region and proportional drift tubes in the central region. Fast muon triggering is achieved using layers of scintillator trigger counters which can be combined with fiber tracker information to enable triggering on low p_T (≥ 1.5 GeV/c) muons. The muon tracker and trigger are operating well within specifications.

The Forward Proton Detector (FPD, E-900) consists of momentum spectrometers which make use of the accelerator magnets along with points measured on the track of the scattered proton (or antiproton) to calculate track

momentum and scattering angle. Tracks are measured using scintillator fiber detectors (read out by multi-channel phototubes) located in Roman pots, which are stainless steel containers that allow the detectors to function outside of the machine vacuum but close to the beam. Particles traverse thin steel windows at the entrance and exit of each pot. The pots are remotely controlled and can be moved close to the beam (within a few mm) during stable beam conditions and retracted otherwise. The FPD detector finished data-taking in February 2006 and is currently in data analysis mode.

The upgraded D0 detector contains approximately one million channels. The data readout is initiated by a multi-level trigger with each level having increased complexity and decision time. The Level 1 trigger is designed for an accept rate of 2-5 kHz depending on the chosen deadtime. Calorimeter-based triggers utilize analog hardware to compute fast energy sums to identify localized electromagnetic and hadronic activity and the presence of missing E_T . Track finding in the CFT and muon tracker are performed by parallel application of field programmable gate arrays; electron candidates can be selected using azimuthal matching between the CFT and CPS.

The Level 2 trigger, which has a 1 kHz accept rate, enables more sophisticated reconstruction and fully exploits correlations between the tracking detectors, calorimeter and muon systems; for example $\eta - \phi$ matching between the preshower and calorimeter. The Level 2 trigger capability has been supplemented by a Silicon Track Trigger (SST; E-908). This device discriminates on tracks measured using the silicon microvertex detector which do not emanate from the primary vertex. Such tracks are efficient indicators of heavy flavor, i.e. b and c quark production. This enhances the triggering capabilities for Higgs bosons and top and bottom quarks. It will also enable triggering on $Z \rightarrow b\bar{b}$, which is a key calibration channel for top and Higgs physics. The STT trigger is fully integrated into the physics trigger menu.

The Level 3 trigger uses a commodity-based PC farm of about 300 nodes running Linux. The availability of fully digitized information permits sophisticated software reconstruction algorithms to be applied. The maximum Level 3 accept rate is around 400 Hz although 50-100 Hz is the usual rate to tape during normal physics running.

The current detector is limited in the instantaneous and integrated luminosities at which it can operate. The present silicon tracker is radiation-hard to withstand about $6-8 \text{ fb}^{-1}$. The Run IIb Upgrade Project (E-925) includes an additional radiation-hard inner layer for the silicon tracker, called Layer-Zero. The additional hits from Layer-Zero improve b-tagging and ameliorate radiation damage to the current inner layers. The upgrade substantially improves the calorimeter and track triggers and CFT front-end electronics in order to handle increased occupancy from higher instantaneous luminosities. The Run IIb Upgrade Project was completed in November 2006 on schedule and under budget. All major Run IIb upgrade systems now participate in the experiment data taking.

The physics goals of D0 involve direct searches for particles and forces not yet known, including both those that are predicted or expected (like the Higgs boson and supersymmetry) and those that would come as a surprise. At the same time we confront the Standard Model through precise measurements of the strong interaction, through measurements of the quark mixing matrix, and through precise measurements of the electroweak force and the properties of the W and Z bosons and the top quark.

D0 has six analysis groups dedicated to electroweak physics, studies of the top quark, studies of the bottom quark, searches for Higgses, searches for new phenomena beyond the Standard Model, and elucidation of the strong force. The physics groups presented about 60 analyses at the summer 2006 conferences. In 2006 D0 published 33 papers or 1.6 times more than in any previous year of D0 history. Among them is a 1 fb^{-1} D0 article on evidence of B_s oscillations – the most cited publication in experimental HEP of 2006. We expect the first 2 fb^{-1} results to appear for 2007 winter conferences. More details from the six analysis groups follow.

With the higher luminosity and the higher center-of-mass energy available in Run II of the Tevatron, the collaboration has embarked on a number of searches for new phenomena. The main searches are organized around manifestations of additional space-time dimensions, for supersymmetric particles, for leptoquarks and for new gauge bosons (which may arise, for instance, from unified theories), and for signs of compositeness of quarks and leptons. The final states investigated cover a wide range of topologies, from high transverse momentum lepton pairs to jets and missing E_T , from multi-lepton to lepton+jets final states. The searches exploit in particular the excellent capabilities of the D0 detector in terms of calorimeter hermeticity and resolution and angular coverage for lepton identification.

Searches for additional space-time dimensions look for deviations from the Drell-Yan spectrum at high di-muon, di-electron or di-photon masses, which could be due to the exchange of gravitons. These deviations can be as spectacular as narrow resonances, or simply a broad enhancement that becomes more and more pronounced as the mass increases. The results obtained place the strongest constraints to date on some models of large extra dimensions. The same di-lepton final states have also been used to set limits on the masses of new gauge bosons and on the scale of compositeness well beyond those previously explored, as well as to further constrain technicolor theories.

Supersymmetric partners of the Standard Model particles have been searched for in a variety of model frameworks. Gauge-mediated supersymmetry predicts that the final states may contain two energetic photons and large missing transverse energy carried away by light gravitinos. The absence of any signal has allowed D0 to extend the exclusion domains for such theories well beyond those established at LEP and in Run I of the Tevatron. In the framework of Supergravity, the most promising avenues are the searches for strongly produced squarks and gluinos on one hand, and for the electroweak associated production of charginos and neutralinos on the other. In the first case, the signatures range from an energetic acoplanar jet pair to multi-jets with

missing E_T . In the second, leptonic decays of the charginos and neutralinos lead to tri-lepton topologies, also with missing E_T arising from the pair of the lightest supersymmetric particles terminating the decay chains. Both of these searches now probe domains that were inaccessible at LEP, well beyond those explored in Run I. The sensitivity of the trilepton search has been greatly improved as signals with all three charged leptons (e , μ , and τ) and high momentum tracks are now included.

Anomaly-mediated supersymmetry might lead to quasi-stable charginos. These would appear as massive stable particles appearing in the detector as slow-moving high transverse momentum particles reconstructed as “muons”. The timing information from the scintillators of the muon system has been used to search for such a signature, and mass limits have been set, again well beyond those previously existing. Finally, in R-parity violating models, the lightest supersymmetric particle would be unstable, which leads to final states containing many leptons or jets, but only moderate missing E_T . A variety of models have been explored, and improved mass limits have been set.

Leptoquarks could be pair produced at the Tevatron. The final states expected consist of *i*) two leptons and two jets, *ii*) a lepton, two jets and missing E_T , or *iii*) an acoplanar pair of jets. All these possibilities have been considered, and the previously excluded mass range has been significantly extended in the case of first and second generation leptoquarks. Finally, an investigation of the heavy flavour content of jets produced in association with a W boson has been conducted, and the possible anomaly reported in Run I has not been substantiated by this analysis.

The Tevatron Collider continues to be the world's only source of top quarks. Though it was discovered twelve years ago (in 1995) by the CDF and D0 collaborations, the measurements performed in Run I were limited by the size of the available data set. In Run II, the improved detector performance and larger integrated luminosity allow for the first time precision measurements in the top quark sector. With a mass of the order of the electroweak scale, there is the intriguing possibility that the top quark may play a special role in the mechanism of electroweak symmetry breaking and open a window to new physics phenomena.

Six years after the beginning of Run II, the large available data sets and level of understanding of the detector achieved are allowing us to extend our knowledge of the top quark. Many of the currently existing measurements at D0 are based on data sets ten times that of Run I measurements. In order to fully outline the top quark profile, a precise understanding of the production mechanisms is mandatory. D0 has performed measurements of the top pair production cross section in all final states (dilepton, lepton+jets and alljets) and makes use of several techniques (event topology, b-tagging, etc.) to discriminate signal from backgrounds.

At a hadron collider, top quarks can also be produced singly via the electroweak interaction, which provides a sensitive probe of the t-W-b vertex, thus allowing a model-independent measurement of the CKM matrix element

$|V_{tb}|$. Such single top production had never been observed before, due to the overwhelming W +jets background. In December 2006 the D0 experiment reported first evidence of single top quark production using a 1 fb^{-1} data set. The observed cross section is in agreement with Standard Model predictions.

One of the high priorities for Run II is the precise determination of the top quark mass since, together with the W mass, it can be used to constrain the mass of the postulated Higgs boson. Present analyses exceed in accuracy the single most precise measurement in Run I (also from D0). The goal is to achieve a total uncertainty on the top quark mass of 2 GeV by the end of Run II. The large (approximately $400 \text{ events}/\text{fb}^{-1}$) and relatively pure (signal-to-background ratio ~ 3) samples of top quarks selected in the lepton+jets channel requiring at least one b-tagged jet are also being used to search for anomalous production of the top quark. Other top properties studied and published by D0 in 2006 include W boson helicity in top decay, the ratio of top decays to b quarks to that for any quark, and top charge.

With respect to the Higgs boson, searches are underway for Standard Model, supersymmetric, and exotic models Higgses. We have started searching for the Standard Model Higgs, with the final states expected both for lower mass and higher mass Higgs bosons. Our first SM Higgs search in the WH , ZH , WW^* , and WWW^* channels have been published. Preliminary results with $\sim 300\text{-}400 \text{ pb}^{-1}$ have been presented for these channels. The limits obtained are about a factor of five away from the SM cross sections but will improve as more data is accumulated and analysis methods are enhanced. A pioneering analysis of inclusive $Z+b$ production, which is one of the most important backgrounds to Higgs production in the ZH mode, was undertaken and has been published. This also happens to be the first experimental probe into the b quark density of the proton. Measurements of Z +jets production and W +jets production properties, with and without b-jets, are also in progress.

Higgs in the Minimal Supersymmetric Model (MSSM) can be easier to detect if $\tan \beta$ (a parameter of the MSSM) is large, due to enhanced production of the Higgs in association with one or two b quarks, with the Higgs itself decaying into a pair of b quarks. A novel technique of background estimation purely from the data was pioneered for this analysis. A result that excludes large regions of parameter space in the $\tan \beta$ vs Higgs mass plane has been presented to the community. We also recently announced results of analyses with taus in the final state in the MSSM scenarios, and we expect these to complement the 3 and 4 b-quark final state results. Searches for exotic models of electroweak symmetry breaking include a search for doubly charged Higgs bosons (the first D0 Run II publication), technicolor particles produced in association with W bosons, and a fermiophobic Higgs that would decay to two photons.

At the Tevatron, W and Z bosons are produced abundantly. When decaying to electrons and muons, these particles provide clean, well-understood experimental signatures. Furthermore, W and Z production cross sections and their properties are well predicted by theory. Therefore, these particles provide standard tools for understanding electron and muon identification, and help determine the momentum scale and resolution of the detector. In D0, we have

measured W and Z production cross sections in electron, muon, and tau channels. The direct measurement of W width has also been carried out by studying the shape of the tail of the W transverse mass distribution in the electron channel.

In the Standard Model, interactions between gauge bosons (W , Z and γ) are precisely defined by $SU(2)\times U(1)$ gauge structure. Studying associated production of di-bosons provides an excellent test of the SM. The measured production cross sections at D0 for WW , $W\gamma$, and $Z\gamma$ are all in agreement with the SM predictions and have been published. In June 2006 D0 announced the first measurement of WZ pair production at the Tevatron – the process with the lowest measured cross section at hadron colliders. These measurements along with the kinematic properties of the final state particles are used to set limits on anomalous triple gauge boson couplings. The limits are the most stringent from the Tevatron and limits are improved with respect to those of LEP.

As mentioned already, precise measurements of the W boson and top quark masses are understood to be among the most important measurements that Tevatron experiments can deliver. These quantities provide an indirect limit on the Higgs boson mass through radiative corrections, and thus can serve as a guide in Higgs particle searches. To fully benefit from the large W data sample available at the Tevatron, it is crucial to precisely calibrate the calorimeter response. This complex task has been completed, clearing the way for an improved measurement of the W mass.

The heavy flavor physics group has capitalized on the excellent performance of the upgraded D0 charged-particle tracking, vertexing, and extensive muon coverage to arrive at a set of highly competitive results. The Tevatron is the only operating accelerator capable of producing the heavier B states such as B_s^0 , Λ_b , and B_c , and our results cover all of these states plus results on the lighter B^+ and B^0 that are competitive and complementary to those from the B factories. Our heavy flavor program covers production, lifetimes, mixing of neutral B states, spectroscopy, branching ratios, rare decays, and studies of CP violation.

In the area of production, a measurement of the differential cross section of $Y(1S)$, with a large reach in the forward region, has been published. Future prospects include the same for J/ψ production, measuring the polarization at production of both these states, as well as the b -jet cross section at large transverse momentum and the b cross section via fully exclusive states. Lifetimes in fully reconstructed exclusive states via $B_s^0 \rightarrow J/\psi\phi$ and $\Lambda_b \rightarrow J/\psi\Lambda^0$ have been published, and the former is the world's best single exclusive B_s^0 lifetime measurement.

A novel technique using the ratio of $B \rightarrow D^0\mu X$ and $B \rightarrow D^{*\mu}X$ event yields as a function of visible proper decay length has been published. A preliminary result using the world's largest sample of the elusive B_c meson through the decay into $J/\psi\mu X$ shows its lifetime to be substantially shorter than the other B hadrons, as expected. Current analyses are exploring fully exclusive decays of the B_c . Mixing (also discussed below) in the B_s^0 sector can give rise to a

difference in lifetimes between CP eigenstates that has been published in the predominantly CP-even mode $B_s^0 \rightarrow J/\psi\phi$, and is complemented by results on the B_s^0 lifetime through its semileptonic decay which is an equal mix of CP-even and CP-odd eigenstates. D0 is the first experiment to explore CP violation in the B_s^0 system. In addition to using the $B_s^0 \rightarrow J/\psi\phi$ channel, D0 has looked for an asymmetry in the rates of B_s^0 to positive and negative muons using its huge sample of di-muon events and also a large semi-exclusive sample of $B_s^0 \rightarrow \mu D_s$. Because the searched-for asymmetries are tiny and are sensitive to small detector asymmetries, these analyses benefit hugely from the practice of reversing the directions of the solenoid and toroid fields at D0 on a regular basis.

We have preliminary results on the orbitally excited D^{**} and D_s^{**} states observed through $B \rightarrow D_s^{**}\mu X$ decays, and also on B^{**} states where the first measurements of the mass splitting between doublet members have been reported. Rare decays can provide first insights on new physics, and we have published the world's best limit on the branching ratio of the flavor-changing neutral-current (FCNC) decay $B_s^0 \rightarrow \mu^+\mu^-$ and have a result on the sensitivity for $B_s^0 \rightarrow \mu^+\mu^-\phi$.

Finally, one of the most crucial B measurements that came from the Tevatron in 2006 is that of B_s^0 oscillations. This allows further understanding of CP violation with an independent constraint in the relevant unitarity triangle. In March 2006 D0 was the first experiment to announce B_s oscillation evidence, with a frequency of 19 ps^{-1} . This frequency is in agreement with SM expectations and provides extra constraints on CKM matrix elements.

The increased Run II center-of-mass energy offers the opportunity to investigate quantum chromodynamics in new kinematic domains. As luminosity has accrued, the inclusive jet cross section is continually updated; jets with transverse energies up to 1 TeV are now observed. The inclusive jet measurement explores the structure of the proton and is a sensitive search for quark substructure. It will help to constrain the gluon content of the proton at large x , where it is very poorly known. A measurement of the azimuthal decorrelation of jets in di-jet production has provided a novel test of perturbative QCD and resulted in the first Tevatron Run II QCD publication. The analysis of the isolated photon cross section has been published.

The year 2006 was very productive for the D0 experiment with many new interesting results obtained and 33 papers published. Evidence of B_s meson oscillations, single top quark production, WZ production and setting limits within a factor of five of SM Higgs production with 1 fb^{-1} assures a continuing rich harvest from the experiment in 2007 and beyond.

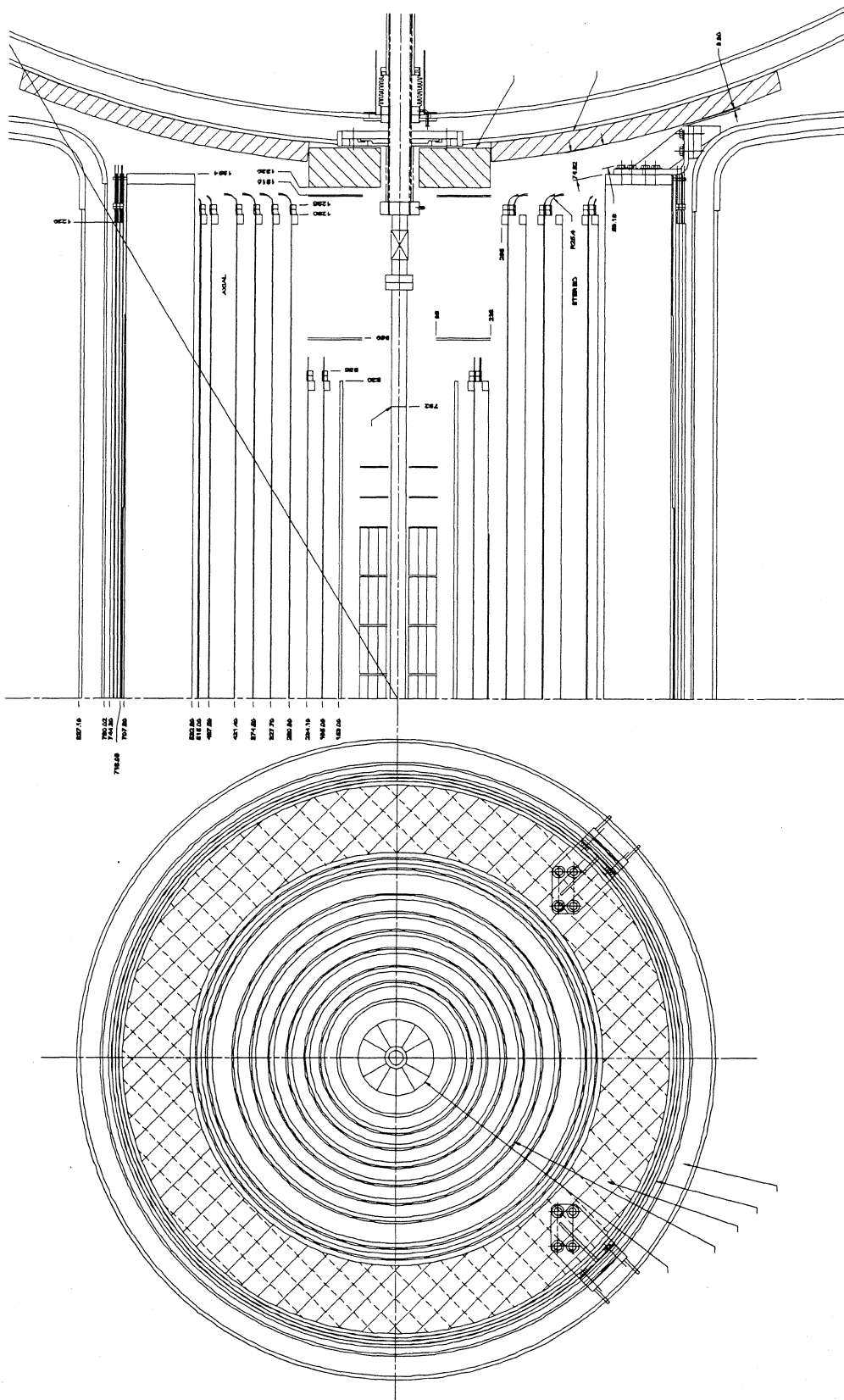

The Run II configuration of the tracking system. Shown are the central silicon vertex tracker, the central scintillating fiber tracker, and the central and forward preshower detectors.

E-900

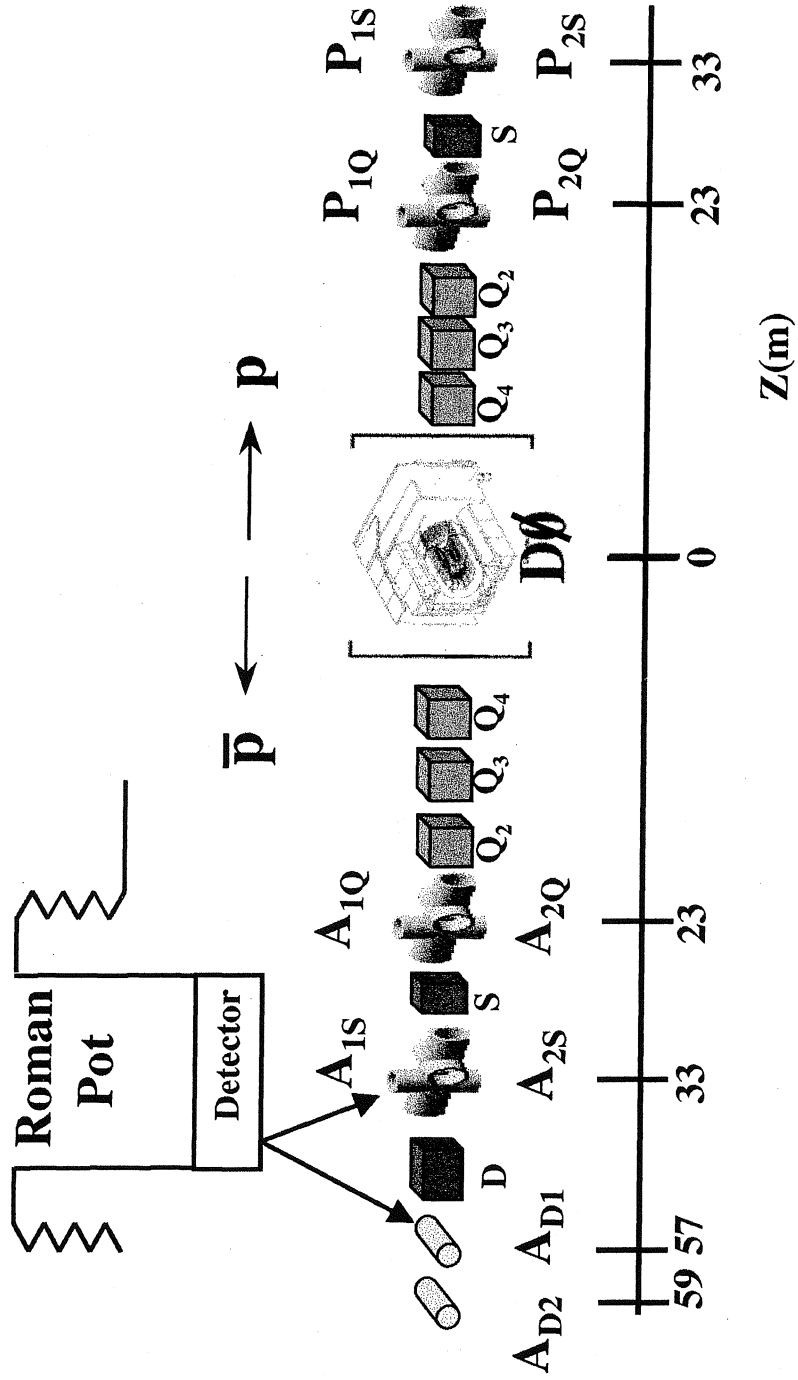

Components of the Forward Proton Detector

Publications

Hadron and Electron Response in a Uranium Liquid Argon Calorimeter from 10-150 GeV, Nucl. Instr. and Meth. A269, 492 (1988).

Hadron and Electron Response of Uranium/Liquid Argon Calorimeter Modules for the D0 Detector, Nucl. Instr. and Meth., A280, 36 (1989).

Beam Tests of the D0 Uranium Liquid Argon End Calorimeters, Nucl. Instr. and Meth. A324, 53 (1993).

The D0 Detector, Nucl. Instr. and Meth. A338, 185 (1994).

First Generation Leptoquark Search in $\bar{p}p$ Collisions at $\sqrt{s} = 1.8$ TeV, Phys. Rev. Lett. 72, 965 (1994).

Search for the Top Quark in $\bar{p}p$ Collisions at $\sqrt{s} = 1.8$ TeV, Phys. Rev. Lett. 72, 2138 (1994).

Rapidity Gaps Between Jets in $\bar{p}p$ Collisions at $\sqrt{s} = 1.8$ TeV, Phys. Rev. Lett. 72, 2332 (1994).

Search for High Mass Top Quark Production in $\bar{p}p$ Collisions at $\sqrt{s} = 1.8$ TeV, Phys. Rev. Lett. 74, 2422 (1995).

Observation of the Top Quark, Phys. Rev. Lett. 74, 2632 (1995).

Inclusive μ and b-Quark Production Cross Sections in $\bar{p}p$ Collisions at $\sqrt{s} = 1.8$ TeV, Phys. Rev. Lett. 74, 3548 (1995).

Search for Squarks and Gluinos in $\bar{p}p$ Collisions at $\sqrt{s} = 1.8$ TeV, Phys. Rev. Lett. 75, 618 (1995).

Search for W Boson Pair Production in $\bar{p}p$ Collisions at $\sqrt{s} = 1.8$ TeV, Phys. Rev. Lett. 75, 1023 (1995).

Limits on the Anomalous $ZZ\gamma$ and $Z\gamma\gamma$ Couplings in $\bar{p}p$ Collisions at $\sqrt{s} = 1.8$ TeV, Phys. Rev. Lett. 75, 1028 (1995).

Measurement of the $WW\gamma$ Gauge Boson Coupling in $\bar{p}p$ Collisions at $\sqrt{s} = 1.8$ TeV, Phys. Rev. Lett. 75, 1034 (1995).

W and Z Boson Production in $\bar{p}p$ Collisions at $\sqrt{s} = 1.8$ TeV, Phys. Rev. Lett. 75, 1456 (1995).

A Study of the Strong Coupling Constant Using W + Jets Processes, Phys. Rev. Lett. 75, 3226 (1995).

Top Quark Search with the D0 1992-93 Data Sample, Phys. Rev. D52, 4877 (1995).

Transverse Energy Distributions within Jets in $\bar{p}p$ Collisions at $\sqrt{s} = 1.8$ TeV, Phys. Lett. B357, 500 (1995).

Search for Heavy W Bosons in 1.8 TeV $\bar{p}p$ Collisions, Phys. Lett. B358, 405 (1995).

Second Generation Leptoquark Search in $\bar{p}p$ Collisions at $\sqrt{s} = 1.8$ TeV, Phys. Rev. Lett. 75, 3618 (1995).

A Detailed Study of Plastic Scintillating Strips with Axial Wavelength Shifting Fiber and VLPC Readout, Nucl. Instr. and Meth. A366, 263 (1995).

Studies of Topological Distributions of Inclusive Three- and Four-Jet Events in $\bar{p}p$ Collisions at $\sqrt{s} = 1800$ GeV with the D0 Detector, Phys. Rev. D53, 6000 (1996).

Jet Production via Strongly-Interacting Color-Singlet Exchange in $\bar{p}p$ Collisions, Phys. Rev. Lett. 76, 734 (1996).

Search for Light Top Squarks in $\bar{p}p$ Collisions at 1.8 TeV, Phys. Rev. Lett. 76, 2222 (1996).

Search for $\tilde{W}_1 \tilde{Z}_2$ Production Via Trilepton Final States in $\bar{p}p$ Collisions at $\sqrt{s} = 1.8$ TeV, Phys. Rev. Lett. 76, 2228 (1996).

Search for Right-Handed W Bosons and Heavy W' in $\bar{p}p$ Collisions at $\sqrt{s} = 1.8$ TeV, Phys. Rev. Lett. 76, 3271 (1996).

- The Azimuthal Decorrelation of Jets Widely Separated in Rapidity, Phys. Rev. Lett. 77, 595 (1996).
- Search for Anomalous WW and WZ Production in $\bar{p}p$ Collisions at $\sqrt{s} = 1.8$ TeV, Phys. Rev. Lett. 77, 3303 (1996).
- J/Psi Production in $\bar{p}p$ Collisions at $\sqrt{s} = 1.8$ TeV, Phys. Lett. B370, 239 (1996).
- Measurement of the W Boson Mass, Phys. Rev. Lett. 77, 3309 (1996).
- Search for Additional Neutral Gauge Bosons, Phys. Lett. B385, 471 (1996).
- The Isolated Photon Cross Section in the Central and Forward Rapidity Region in $\bar{p}p$ Collisions at $\sqrt{s} = 1.8$ TeV, Phys. Rev. Lett. 77, 5011 (1996).
- A New Detector Technique Using Triangular Scintillating Strips to Achieve Precise Position Measurements for Minimum Ionizing Particles, Nucl. Instr. and Meth. A378, 131 (1996).
- Limits on Anomalous $WW\gamma$ Couplings from $\bar{p} \rightarrow W\gamma+X$ Events at $\sqrt{s} = 1.8$ TeV, Phys. Rev. Lett. 78, 3634 (1997).
- Search for a Fourth Generation Charge $-1/3$ Quark Via Flavor Changing Neutral Current Decay, Phys. Rev. Lett. 78, 3818 (1997).
- Search for Diphoton Events with Large Missing Transverse Energy in $\bar{p}p$ Collisions at $\sqrt{s} = 1.8$ TeV, Phys. Rev. Lett. 78, 2070 (1997).
- Study of the $ZZ\gamma$ and $Z\gamma\gamma$ Couplings in $Z(\rightarrow \nu\nu)\gamma$ Production, Phys. Rev. Lett. 78, 3640 (1997).
- Direct Measurement of the Top Quark Mass, Phys. Rev. Lett. 79, 1197 (1997).
- Studies of Gauge Boson Pair Production and Trilinear Couplings, Phys. Rev. D56, 6742 (1997).
- Measurement of the Top Quark Pair Production Cross Section in $\bar{p}p$ Collisions, Phys. Rev. Lett. 79, 1203 (1997).
- Limits on WWZ and $WW\gamma$ Couplings from $\bar{p}p \rightarrow e\nu jjX$ Events at $\sqrt{s} = 1.8$ TeV, Phys. Rev. Lett. 79, 1441 (1997).
- Search for Scalar Leptoquark Pairs Decaying to Electrons and Jets in $\bar{p}p$ Collisions, Phys. Rev. Lett. 79, 4321 (1997).
- Color Coherent Radiation in Multijet Events from $\bar{p}p$ Collisions at $\sqrt{s} = 1.8$ TeV, Phys. Lett. B414, 419 (1997).
- Scintillation Counters for the D0 Muon Upgrade, Nucl. Instr. and Meth. A401, 45 (1997).
- Experimental Search for Chargino and Neutralino Production in Supersymmetry Models with a Light Gravitino, Phys. Rev. Lett. 80, 442 (1998).
- Measurement of Dijet Angular Distributions and Search for Quark Compositeness, Phys. Rev. Lett. 80, 666 (1998).
- Search for the Trilepton Signature from the Associated Production of SUSY $\tilde{\chi}_1^\pm \tilde{\chi}_2^0$ Gauginos, Phys. Rev. Lett. 80, 1591 (1998).
- Search for First Generation Scalar Leptoquark Pairs in $\bar{p}p$ Collisions at $\sqrt{s} = 1.8$ TeV, Phys. Rev. Lett. 80, 2051 (1998).
- Measurement of the Top Quark Mass Using Dilepton Events, Phys. Rev. Lett. 80, 2063 (1998).
- Search for Top Squark Pair Production in the Dielectron Channel, Phys. Rev. D57, 589 (1998).
- $Z\gamma$ Production in $\bar{p}p$ Collisions at $\sqrt{s} = 1.8$ TeV and Limits on Anomalous $ZZ\gamma$ and $Z\gamma\gamma$ Couplings, Phys. Rev. D57, 3817 (1998).
- Direct Measurement of Top Quark Mass by the D0 Collaboration, Phys. Rev. D58, 052001 (1998).
- A Measurement of the W Boson Mass, Phys. Rev. D58, 092003 (1998).
- Determination of the Mass of the W Boson Using the D0 Detector at the Tevatron, Phys. Rev. D58, 12002 (1998).

A Measurement of the W Boson Mass at the Fermilab $\bar{p}p$ Collider, Phys. Rev. Lett. 80, 3008 (1998).

Search for the Decay $b \rightarrow s\mu\mu$, Phys. Lett. B423, 419 (1998).

Measurement of the Shape of the Transverse Momentum Distribution of W Bosons Produced in $\bar{p}p$ Collisions at $\sqrt{s} = 1.8$ TeV, Phys. Rev. Lett. 80, 5498 (1998).

Limits on $WW\gamma$ and WWZ Couplings from W Boson Pair Production, Phys. Rev. D58, Rapid Communications, 051101 (1998).

Search for Charge 1/3 Third Generation Leptoquarks in $\bar{p}p$ Collisions at $\sqrt{s} = 1.8$ TeV, Phys. Rev. Lett. 81, 38 (1998).

Limits on Anomalous $WW\gamma$ and WWZ Couplings, Phys. Rev. D58, Rapid Communications, 31102 (1998).

Search for Heavy Pointlike Dirac Monopoles, Phys. Rev. Lett. 81, 524 (1998).

The D0 Detector at TeV33, FERMILAB PUB-98/124-E, hep-ex/9804011.

Combined Limits on First Generation Leptoquarks from the CDF and D0 Experiments, FERMILAB PUB-98/312-E, hep-ex/9810015.

Determination of the Absolute Jet Energy Scale in the D0 Calorimeters, Nucl. Instr. and Meth. A424, 352 (1999).

Small Angle J/Psi Production in $\bar{p}p$ Collisions at $\sqrt{s} = 1.8$ TeV, Phys. Rev. Lett. 83, 35 (1999).

Search for Squarks and Gluinos in Single-Photon Events with Jets and Large Missing Transverse Energy in $\bar{p}p$ Collisions at $\sqrt{s} = 1.8$ TeV, Phys. Rev. Lett. 82, 29 (1999).

Probing Hard Color-Singlet Exchange in $\bar{p}p$ Collisions at $\sqrt{s} = 630$ GeV and 1800 GeV, Phys. Lett. B440, 189 (1998).

Search for Nonstandard Higgs Bosons Using High Mass Photon Pairs in $\bar{p}p \rightarrow \gamma\gamma + 2$ Jets at $\sqrt{s} = 1.8$ TeV, Phys. Rev. Lett. 82, 2244 (1999).

The Inclusive Jet Cross Section in $\bar{p}p$ Collisions at $\sqrt{s} = 1.8$ TeV, Phys. Rev. Lett. 82, 2451, (1999).

The Dijet Mass Spectrum and a Search for Quark Compositeness in $\bar{p}p$ Collisions at $\sqrt{s} = 1.8$ TeV, Phys. Rev. Lett. 82, 2457 (1999).

Measurement of the Top Quark Pair Production Cross Section in $\bar{p}p$ Collisions using Multijet Final States, Phys. Rev. D60, 012001 (1999).

Search for Bottom Squarks in $\bar{p}p$ Collisions at $\sqrt{s} = 1.8$ TeV, Phys. Rev. D60, Rapid Communications, 031101 (1999).

Measurement of the Top Quark Mass in the Dilepton Channel, Phys. Rev. D60, 052001 (1999).

Measurement of the High-Mass Drell-Yan Cross Section and Limits on Quark-Electron Compositeness Scales, Phys. Rev. Lett. 82, 4769 (1999).

Search for Charged Higgs Bosons in Decays of Top Quark Pairs, Phys. Rev. Lett. 82, 4975 (1999).

Measurement of the Top Quark Pair Production Cross Section in the All-Jets Decay Channel, Phys. Rev. Lett. 83, 1908 (1999).

Measurement of W and Z Boson Production Cross Sections, Phys. Rev. D60, 052003 (1999).

Studies of WW and WZ Production and Limits on Anomalous $WW\gamma$ and WWZ Couplings, Phys. Rev. D60, 072002 (1999).

Evidence of Color Coherence Effects in W + Jets Events from $\bar{p}p$ Collisions at $\sqrt{s} = 1.8$ TeV, Phys. Lett. B464, 145 (1999).

Search for Squarks and Gluinos in Events Containing Jets and a Large Imbalance in Transverse Momentum, Phys. Rev. Lett. 83, 4937 (1999).

- Search for Second Generation Leptoquark Pairs Decaying into $\mu\nu + \text{Jets}$ in $\bar{p}p$ Collisions at $\sqrt{s} = 1.8$ TeV, Phys. Rev. Lett. 83, 2896 (1999).
- Search for R-parity Violation Supersymmetry in the Dielectron Channel, Phys. Rev. 83, 4476 (1999).
- Combining the Top Quark Mass Results for Run I from CDF and D0, FERMILAB-TM-2084 (1999).
- The $b\bar{b}$ Production Cross Section and Angular Correlations in $\bar{p}p$ Collisions at $\sqrt{s} = 1.8$ TeV, Phys. Lett. B487, 264 (2000).
- Measurement of the Inclusive Differential Cross Section for Z Bosons as a Function of Transverse Momentum Produced in $\bar{p}p$ Collisions at $\sqrt{s} = 1.8$ TeV, Phys. Rev. D61, 032004 (2000).
- Extraction of the Width of the W Boson from Measurements of $\sigma(p\bar{p} \rightarrow W + X) \times \text{Br}(W \rightarrow e\nu)$ and $\sigma(p\bar{p} \rightarrow Z + X) \times \text{Br}(Z \rightarrow ee)$ and Their Ratio, Phys. Rev. D61, 072001 (2000).
- A Measurement of the W Boson Mass Using Electrons at Large Rapidities, Phys. Rev. Lett. 84, 222 (2000).
- Search for Second Generation Leptoquarks in $\bar{p}p$ Collisions at $\sqrt{s} = 1.8$ TeV, Phys. Rev. Lett. 84, 2088 (2000).
- The Isolated Photon Cross-Section in $\bar{p}p$ Collisions at $\sqrt{s} = 1.8$ TeV, Phys. Rev. Lett. 84, 2786 (2000).
- Differential Production Cross Section of Z Bosons as a Function of Transverse Momentum at $\sqrt{s} = 1.8$ TeV, Phys. Rev. Lett. 84, 2792 (2000).
- Small Angle Muon and Bottom Quark Production in $\bar{p}p$ Collisions at $\sqrt{s} = 1.8$ TeV, Phys. Rev. Lett. 84, 5478 (2000).
- Limits on Anomalous $WW\gamma$ and WWZ Couplings from $WW/WZ \rightarrow e\nu jj$ Production, Phys. Rev. D62, 052005 (2000).
- Search for New Physics in e mu X Data at D0 Using Sleuth: A Quasi-Model-Independent Search Strategy for New Physics, Phys. Rev. D62, 92004 (2000).
- A Measurement of the W Boson Mass Using Large Rapidity Electrons, Phys. Rev. D62, 092006 (2000).
- Limits on Quark Compositeness from High Energy Jets in $\bar{p}p$ Collisions at 1.8 TeV, Phys. Rev. D62, Rapid Communications, 031101 (2000).
- A Measurement of the $W \rightarrow \tau\nu$ Production Cross Section in $\bar{p}p$ Collisions at $\sqrt{s} = 1.8$ TeV, Phys. Rev. Lett. 84, 5710 (2000).
- Probing BFKL Dynamics in Dijet Cross Section at Large Rapidity Intervals in $\bar{p}p$ Collisions at $\sqrt{s} = 1800$ and 630 GeV, Phys. Rev. Lett. 84, 5722 (2000).
- Spin Correlation in $t\bar{t}$ Production from $\bar{p}p$ Collisions at $\sqrt{s} = 1800$ GeV, Phys. Rev. Lett. 85, 256 (2000).
- Search for R-Parity Violation in Multilepton Final States in $\bar{p}p$ Collisions at $\sqrt{s} = 1.8$ TeV, Phys. Rev. D62, Rapid Communications, 071701 (2000).
- Cross Section for b Jet Production in $\bar{p}p$ Collisions at $\sqrt{s} = 1.8$ TeV, Phys. Rev. Lett. 85, 5068 (2000).
- A Search for Dilepton Signature from Minimal Low-energy Supergravity $\bar{p}p$ Collisions at 1800 GeV, Phys. Rev. D Rapid Comm. 63, 091102 (2001).
- Search for Electroweak Production of Single Top Quarks in $\bar{p}p$ Collisions, Phys. Rev. D Rapid Comm. 63, 031101 (2001).
- Search for Large Extra Dimensions in Dielectron and Diphoton Production, Phys. Rev. Lett. 86, 1156 (2001).

- The Ratio of Jet Cross Sections at $\sqrt{s} = 630$ GeV and 1800 GeV, Phys. Rev. Lett. 86, 2523 (2001).
- Ratios of Multijet Cross Sections in $\bar{p}p$ Collisions at $\sqrt{s} = 1800$ GeV, Phys. Rev. Lett. 86, 1955 (2001).
- Measurement of the Angular Distribution of Electrons from $W \rightarrow e\nu$ Decays Observed in $\bar{p}p$ Collisions at $\sqrt{s} = 1.8$ TeV, Phys. Rev. D63, 072001 (2001).
- Differential Cross Section for W Boson Production as a Function of Transverse Momentum in $\bar{p}p$ Collisions at $\sqrt{s} = 1.8$ TeV, Phys. Lett. B513, 292 (2001).
- Inclusive Jet Production in $\bar{p}p$ Collisions, Phys. Rev. Lett. 86, 1707 (2001).
- A Quasi-Model-Independent Search for New High p_T Physics at D0, Phys. Rev. Lett. 86, 3712 (2001).
- A Quasi-Model-Independent Search for New Physics at Large Transverse Momentum, Phys. Rev. D64, 012004 (2001).
- High- p_T Jets in $\bar{p}p$ Collisions at $\sqrt{s} = 630$ and 1800 GeV, Phys. Rev. D64, 032003 (2001).
- Search for Heavy Particles Decaying into Electron-Positron Pairs in $\bar{p}p$ Collisions, Phys. Rev. Lett. 87, 061802 (2001).
- Search for First-Generation Scalar and Vector Leptoquarks, Phys. Rev. D64, 092004 (2001).
- Search for New Physics Using QUAERO: A General Interface to D0 Data, Phys. Rev. Lett. 87, 012004 (2001).
- Search for Single Top Production at D0 Using Neural Networks, Phys. Lett. B517, 282 (2001).
- Measurement of the Ratio of Differential Cross Sections for W and Z Boson Production as a Function of Transverse Momentum, Phys. Lett. B517, 299 (2001).
- The Ratio of Isolated Photon Cross Sections in $\bar{p}p$ Collisions at $\sqrt{s} = 630$ and 1800 GeV, Phys. Rev. Lett. 87, 251805 (2001).
- Direct Search for Charged Higgs Bosons in Decays of Top Quarks, Phys. Rev. Lett. 88, 151803 (2001).
- A Search for the Scalar Top Quark in $\bar{p}p$ Collisions at $\sqrt{s} = 1.8$ TeV, Phys. Rev. Lett. 88, 171802 (2002).
- The Inclusive Jet Cross Section in $\bar{p}p$ Collisions at $\sqrt{s} = 1.8$ TeV Using the k_T Algorithm, Phys. Lett. B525, 211 (2002).
- Hard Single Diffraction in $\bar{p}p$ Collisions at $\sqrt{s} = 630$ and 1800 GeV, Phys. Lett. B531, 52 (2002).
- Search for Leptoquark Pairs Decaying to $\nu\nu$ +Jets in $\bar{p}p$ Collisions at $\sqrt{s} = 1.8$ TeV, Phys. Rev. Lett. 88, 191801 (2002).
- Search for R-Parity Violating Supersymmetry in Dimuon and Four-Jets Channel, Phys. Rev. Lett. 89, 171801 (2002).
- Subjet Multiplicity of Gluon and Quark Jets Reconstructed Using the k_T Algorithm in $\bar{p}p$ Collisions, Phys. Rev. D65, 052008 (2002).
- A Direct Measurement of the W Boson Width, Phys. Rev. D66, 032008 (2002).
- Improved W Boson Mass Measurement with the D0 Detector, Phys. Rev. D66, 012001 (2002).
- Search for mSUGRA in Single-Electron Events with Jets and Large Missing Transverse Energy in $\bar{p}p$ Collisions at $\sqrt{s} = 1.8$ TeV, Phys. Rev. D66, 112001 (2002).
- Search for the Production of Single Sleptons Through R-Parity Violation in $\bar{p}p$ Collisions at $\sqrt{s} = 1.8$ TeV, Phys. Rev. Lett. 89, 261801 (2002).
- $\bar{t}\bar{t}$ Production Cross Section in $\bar{p}p$ Collisions at $\sqrt{s} = 1.8$ TeV, Phys. Rev. D67, 012004 (2003).
- Multiple Jet Production at Low Transverse Energies in $\bar{p}p$ Collisions at $\sqrt{s} = 1.8$ TeV, Phys. Rev. D67, 052001 (2003).

Search for Large Extra Dimensions in the Monojet + MET Channel with the DZero Detector, Phys. Rev. Lett. 90, 251802 (2003).

Observation of Diffractively Produced W and Z Bosons in $p\bar{p}$ Collisions at $\sqrt{s} = 1.8$ TeV, Phys. Lett. B574, 169 (2003).

Search for Narrow $\bar{t}t$ Resonances in $p\bar{p}$ Collisions at $\sqrt{s} = 1.8$ TeV, Phys. Rev. Lett. 92, 221801 (2004).

Search for 3- and 4-Body Decays of the Scalar Top Quark in $p\bar{p}$ Collisions at $\sqrt{s} = 1.8$ TeV, Phys. Lett. B581, 147 (2004).

Search for New Particles in the Two-Jet Decay Channel with the D0 Detector, PRD Rapid Comm. 69, 111101 (2004).

An Improved Measurement of the Top Quark Mass, Nature 429, 638 (2004).

Search for Pair Production of Light Scalar Top Quarks in $p\bar{p}$ Collisions at $\sqrt{s} = 1.8$ TeV, Phys. Rev. Lett. 93, 011801 (2004).

Combination of CDF and D0 Results on W Boson Mass and Width, Phys. Rev. D70, 092008 (2004).

Search for Doubly-Charged Higgs Boson Pair Production in the Decay to $\mu^+\mu^+\mu^-\mu^-$ in $p\bar{p}$ Collisions at $\sqrt{s} = 1.96$ TeV, Phys. Rev. Lett. 93, 141801 (2004).

Observation and Properties of the X(3872) Decaying to $J/\psi \pi^+\pi^-$ in $p\bar{p}$ Collisions at $\sqrt{s} = 1.96$ TeV, Phys. Rev. Lett. 93, 162002 (2004).

Search for Supersymmetry with Gauge-Mediated Breaking in Diphoton Events at DZero, Phys. Rev. Lett. 94, 041801 (2005).

Measurement of the B_s^0 Lifetime in the Exclusive Decay Channel $B_s^0 \rightarrow J/\psi\phi$, Phys. Rev. Lett. 94, 042001 (2005).

A Search for the Flavor-Changing Neutral Current Decay $B_s^0 \rightarrow \mu^+\mu^-$ in $p\bar{p}$ Collisions at $\sqrt{s} = 1.96$ TeV, Phys. Rev. Lett. 94, 071802 (2005).

Measurement of Dijet Azimuthal Decorrelations at Central Rapidities in $p\bar{p}$ Collisions at $\sqrt{s} = 1.96$ TeV, Phys. Rev. Lett. 94, 221801 (2005).

Measurement of the Ratio of B^+ and B^0 Meson Lifetimes, Phys. Rev. Lett. 94, 182001 (2005).

Measurement of the Lambda-B Lifetime in the Decay $\Lambda\text{-}B \rightarrow J/\psi \Lambda$ with the D0 Detector, Phys. Rev. Lett. 94, 102001 (2005).

A Search for Wbb and WH Production in $p\bar{p}$ Collisions at $\sqrt{s} = 1.96$ TeV, Phys. Rev. Lett. 94, 091802 (2005).

Measurement of the WW Production Cross Section in $p\bar{p}$ Collisions at $\sqrt{s} = 1.96$ TeV, Phys. Rev. Lett. 94, 151801 (2005).

A Measurement of the Ratio of Inclusive Cross Sections $p\bar{p} \rightarrow Zb/p\bar{p} \rightarrow Zj$ at $\sqrt{s} = 1.96$ TeV, Phys. Rev. Lett. 94, 161801 (2005).

A Search for Anomalous Heavy-Flavor Quark Production in Association with W Bosons, Phys. Rev. Lett. 94, 152002 (2005).

First Measurement of $\sigma(p\bar{p} \rightarrow Z) \times \text{Br}(Z \rightarrow \tau\tau)$ at $\sqrt{s} = 1.96$ TeV, Phys. Rev. D71, 072004 (2005).

Search for First-Generation Scalar Leptoquarks in $p\bar{p}$ Collisions at $\sqrt{s} = 1.96$ TeV, Phys. Rev. D Rapid Comm. 71, 071104 (R) (2005).

Study of $Z\gamma$ Events and Limits on Anomalous $ZZ\gamma$ and $Z\gamma\gamma$ Couplings in $p\bar{p}$ Collisions at $\sqrt{s} = 1.96$ TeV, Phys. Rev. Lett. 95, 051802 (2005).

Measurement of Inclusive Differential Cross Sections for $\Upsilon(1S)$ Production in $p\bar{p}$ Collisions at $\sqrt{s} = 1.96$ TeV, Phys. Rev. Lett. 94, 232001 (2005).

Measurement of the $p\bar{p} \rightarrow W\gamma + X$ Cross Section and Limits on Anomalous $WW\gamma$ Couplings at $\sqrt{s} = 1.96$ TeV, Phys. Rev. D Rapid Comm. 71, 091108 (2005).

Production of WZ Events in $\bar{p}p$ Collisions at $\sqrt{s} = 1.96$ TeV and Limits on Anomalous WWZ Couplings, Phys. Rev. Lett. 95, 141802 (2005).

Search for Neutral Supersymmetric Higgs Bosons in Multijet Events at $\sqrt{s} = 1.96$ TeV, Phys. Rev. Lett. 95, 151801 (2005).

Measurement of the $t\bar{t}$ Cross Section in $\bar{p}p$ Collisions at $\sqrt{s} = 1.96$ TeV Using Kinematic Characteristics of Lepton Plus Jets Events, Phys. Lett. B626, 45 (2005).

Measurement of the $t\bar{t}$ Cross Section in $\bar{p}p$ Collisions at $\sqrt{s} = 1.96$ TeV Using Lepton Plus Jets Events with Lifetime b-Tagging, Phys. Lett. B626, 35 (2005).

Search for Supersymmetry Via Associated Production of Charginos and Neutralinos in Final States with Three Leptons, Phys. Rev. Lett. 95, 151805 (2005).

Search for Randall-Sundrum Gravitons in Dilepton and Diphoton Final States, Phys. Rev. Lett. 95, 091801 (2005).

Search for Right-Handed W Bosons in Top Quark Decay, Phys. Rev. D Rapid Comm. 72, 011104 (R) (2005).

Search for Single Top Quark Production in $\bar{p}p$ Collisions at $\sqrt{s} = 1.96$ TeV, Phys. Lett. B622, 265 (2005).

Measurement of the $t\bar{t}$ Production Cross Section in $\bar{p}p$ Collisions at $\sqrt{s} = 1.96$ TeV in Dilepton Final States, Phys. Lett. B626, 55 (2005).

Search for Large Extra Spatial Dimensions in Dimuon Production at DZero, Phys. Rev. Lett. 95, 161602 (2005).

Measurement of the Lifetime Difference in the B_s System, Phys. Rev. Lett. 95, 171801 (2005).

Measurement of Semileptonic Branching Fractions of B Mesons to Narrow D^{**} States, Phys. Rev. Lett. 95, 171803 (2005).

Search for the Higgs Boson in $H \rightarrow WW^{(*)}$ Decays in $\bar{p}p$ Collisions at $\sqrt{s} = 1.96$ TeV, Phys. Rev. Lett. 96, 011801 (2006).

Measurement of the Lifetime Difference in the B_s system, Phys. Rev. Lett. 95, 171801 (2005).

The Upgraded D0 Detector, Nucl. Instr. and Meth. A565, 463 (2006).

Measurements of the Isolated Photon Cross Section in $\bar{p}p$ Collisions at $\sqrt{s} = 1.96$ TeV, Phys. Lett. B639, 151 (2006).

Search for Pair Production of Second Generation Scalar Leptoquarks in $\bar{p}p$ Collisions at $\sqrt{s} = 1.96$ TeV, Phys. Lett. B636, 183 (2006).

Direct Limits on the B_s^0 Oscillation Frequency, Phys. Rev. Lett. 97, 021802 (2006).

Measurement of $B(t \rightarrow bW)/B(t \rightarrow qW)$ at $\sqrt{s} = 1.96$ TeV, Phys. Lett. B639, 616 (2006).

Search for the Rare Decay $B_s^0 \rightarrow \phi\mu^+\mu^-$ with the D0 Detector, Phys. Rev. D Rap. Comm. 74, 031107 (2006).

Search for Squarks and Gluinos in Events with Jets and Missing Transverse Energy in $\bar{p}p$ Collisions at $\sqrt{s} = 1.96$ TeV, Phys. Lett. B638, 119 (2006).

Search for Excited Muons in $\bar{p}p$ Collisions at $\sqrt{s} = 1.96$ TeV, Phys. Rev. D Rap. Comm. 73, 111102 (2006).

Search for Particles Decaying to a Z Boson and a Photon in $p\bar{p}$ Collisions at $\sqrt{s} = 1.96$ TeV, Phys. Lett. B641, 415 (2006).

Search for R-parity Violating Supersymmetry Via the LLE Couplings Λ_{121} , Λ_{122} , or Λ_{133} in $\bar{p}p$ Collisions at $\sqrt{s} = 1.96$ TeV, Phys. Lett. B638, 441 (2006).

Search for Neutral Higgs Bosons Decaying to Tau Pairs in $\bar{p}p$ Collisions at $\sqrt{s} = 1.96$ TeV, Phys. Rev. Lett. 97, 121802 (2006).

Measurement of the B_s^0 Lifetime Using Semileptonic Decays, Phys. Rev. Lett. 97, 241801 (2006).

Search for Resonant 2nd Generation Slepton Production at the Tevatron, Phys. Rev. Lett. 97, 111801 (2006).

Search for Heavy Resonance Decaying into a Z+jet Final State in $p\bar{p}$ Collisions at $\sqrt{s} = 1.96$ TeV Using the D0 Detector, Phys. Rev. D Rapid Comm. 74, 100104 (2006).

Search for Neutral Long Lived Particles Decaying to Two Muons in $p\bar{p}$ Collisions at $\sqrt{s} = 1.96$ TeV, Phys. Rev. Lett. 97, 161802 (2006).

Search for Associated Higgs Boson Production $WH \rightarrow WWW^* \rightarrow l^\pm l^\pm + X$ in $p\bar{p}$ Collisions at $\sqrt{s} = 1.96$ TeV, Phys. Rev. Lett. 97, 151804 (2006).

Search for the W' Decay in the Top Quark Channel, Phys. Lett. B641, 423 (2006).

Search for Pair Production of Scalar Bottom Quarks in $p\bar{p}$ Collisions at $\sqrt{s} = 1.96$ TeV, Phys. Rev. Lett. 97, 171806 (2006).

Limits on Anomalous Trilinear Gauge Couplings from $WW \rightarrow ee$, $WW \rightarrow e\mu$, and $WW \rightarrow \mu\mu$ Events from $p\bar{p}$ collisions at $\sqrt{s} = 1.96$ TeV, Phys. Rev. D Brief Rep. 74, 057101 (2006).

Experimental Discrimination Between Charge $2e/3$ Top Quark and Charge $4e/3$ Exotic Quark Production Scenarios, Phys. Rev. Lett. 98, 041801 (2007).

Search for the Standard Model Higgs Boson in the $p\bar{p} \rightarrow ZH \rightarrow \nu\bar{\nu} b\bar{b}$ Channel, Phys. Rev. Lett. 97, 161803 (2006).

Search for Scalar Leptoquarks in the Acoplaner Jet Topology, Phys. Lett. B640, 230 (2006).

Measurement of the CP-Violating Parameter of B^0 Mixing and Decay in the $p\bar{p} \rightarrow \mu\mu X$ Data, Phys. Rev. D74, 092001 (2006).

Measurement of B_d Mixing Using Opposite-side Flavor Tagging, Phys. Rev. D74, 112002 (2006).

Measurement of the W Boson Helicity in Top Quark Decay at D0, Phys. Rev. D Rapid. Comm. 75, 031102(R) (2007).

Search for the Pair Production of Scalar Top Quarks in the Acoplaner Charm Jet Final State in $p\bar{p}$ Collisions at $\sqrt{s} = 1.96$ TeV, Phys. Lett. B645, 119 (2007).

Measurement of the $t\bar{t}$ Cross Section in $p\bar{p}$ Collisions at $\sqrt{s} = 1.96$ TeV Using Secondary Vertex b-tagging, Phys. Rev. D74, 112004 (2006).

Ph.D. Theses

F. Feinstein	Univ. Paris Sud	December 1987
T. Behnke	SUNY/Stony Brook	August 1989
D. Pizzuto	SUNY/Stony Brook	December 1991
R. Astur	Michigan State University	June 1992
S. Rajagopalan	Northwestern University	June 1992
J. Bantley	Northwestern University	June 1992
J. Kotcher	New York University	October 1992
B. Pi	Michigan State University	November 1992
T. Heuring	SUNY/Stony Brook	May 1993
T. Geld	University of Michigan	May 1993
S. Durston	University of Rochester	June 1993
A. Milder	University of Arizona	August 1993
J. Yu	SUNY/Stony Brook	August 1993
D. Norman	University of Maryland	September 1993
J. Cochran	SUNY/Stony Brook	December 1993
A. Pluquet	Saclay/Univ. Paris	January 1994
R. Hirosky	University of Rochester	January 1994
J. Thompson	SUNY/Stony Brook	April 1994
J. Borders	University of Rochester	April 1994
Q. Zhu	New York University	April 1994
R. Hall	University of California/Riverside	May 1994

M. Paterno	SUNY/Stony Brook	May 1994
B. May	University of Arizona	August 1994
D. Chakraborty	SUNY/Stony Brook	September 1994
M. Pang	Iowa State University	November 1994
V. Balamurali	University of Notre Dame	November 1994
G. Landsberg	SUNY/Stony Brook	November 1994
B. Abbott	Purdue University	December 1994
R. Demina	Northeastern University	December 1994
C. Murphy	Indiana University	April 1995
H. Johari	Northeastern University	April 1995
S. Snyder	SUNY/Stony Brook	May 1995
D. Elvira	Buenos Aires	May 1995
C. Gerber	Buenos Aires	May 1995
G. Lima	LAFEX/CBPF	May 1995
G. Eppley	Rice University	May 1995
M. Goforth	Florida State University	June 1995
J. Jiang	SUNY/Stony Brook	June 1995
J. Yang	New York University	June 1995
A. Smith	University of Arizona	August 1995
S. Fahey	Michigan State University	August 1995
R. Madden	Florida State University	August 1995
V. Oguri	LAFEX/CBPF	August 1995
P. Rubinov	SUNY/Stony Brook	August 1995
T. Huehn	University of California/Riverside	September 1995
H. Xu	Brown University	September 1995
J. Balderston	University of Hawaii	October 1995
E. James	University of Arizona	November 1995
C. Kim	Korea University	December 1995
C. Cretsinger	University of Rochester	December 1995
Y. Liu	Northwestern University	December 1995
A. Goldschmidt	University of California/Berkeley	January 1996
D. Fein	University of Arizona	February 1996
E. Amidi	Northwestern University	February 1996
C. Yoshikawa	University of Hawaii	March 1996
M. Sosebee	University of Texas/Arlington	March 1996
M. Kelly	University of Notre Dame	April 1996
F. Nang	Brown University	April 1996
J.-F. Lebrat	University of Paris XI	May 1996
H. Li	SUNY/Stony Brook	May 1996
G. Alvarez	University of Indiana	June 1996
S. Chang	Northeastern University	August 1996
T. Hu	SUNY/Stony Brook	August 1996
E. Flattum	Michigan State University	August 1996
S. Glenn	University of California/Davis	August 1996
J. McKinley	Michigan State University	August 1996
E. Won	University of Rochester	October 1996
D. Vititoe	University of Arizona	October 1996
J. Jaques	University of Notre Dame	October 1996
M. Martin	University of Barcelona	October 1996
A. Belyaev	Moscow State Univ.	November 1996
T. Fahland	Brown University	December 1996
K. Fatyga	University of Rochester	December 1996
R. Kehoe	University of Notre Dame	January 1997
I. Adam	Columbia University	February 1997
A. Sanchez-Hernandez	CINVESTAV	February 1997
P. Grudberg	University of California/Berkeley	February 1997
D. Cullen-Vidal	Brown University	March 1997
C. Shaffer	Florida State University	March 1997
E. Varnes	University of California/Berkeley	April 1997
S. Jun	Northwestern University	May 1997

T. Joffe-Minor	Northwestern University	May 1997
J. Tarazi	University of California/Irvine	June 1997
A. Lyon	University of Maryland	June 1997
A. Narayanan	University of Arizona	July 1997
T. Taylor Thomas	Northwestern University	September 1997
P. Tamburello	University of Maryland	September 1997
H. Shankar	Tata Institute	September 1997
M. Bhattacharjee	Delhi University	October 1997
J. Gonzalez-Solis	CINVESTAV	October 1997
A. Hernandez-Montoya	CINVESTAV	October 1997
S. Jerger	Michigan State University	October 1997
B. Lauer	Iowa State University	October 1997
L. Magana-Mendoza	CINVESTAV	October 1997
G. Wang	Florida State University	November 1997
D. Wirjawan	Texas A&M University	December 1997
S. Chopra	University of Michigan	December 1997
W. Chen	SUNY/Stony Brook	December 1997
V. Bhatnagar	Panjab University	December 1997
D. Casey	University of Rochester	December 1997
F. Hsieh	University of Michigan	January 1998
A. Snajder	LAFEX/CBPF	February 1998
Y. Yu	Seoul National University	February 1998
P. Bloom	University of California/Davis	February 1998
T. McKibben	University of Illinois/Chicago	February 1998
W. Carvalho	LAFEX/CBPF	March 1998
J. Perkins	University of Texas/Arlington	April 1998
T. Hu	University of Indiana	April 1998
K. S. Hahn	University of Rochester	April 1998
P. Gartung	University of California/Riverside	September 1998
J. Krane	University of Nebraska	November 1998
G. Di Loreto	Michigan State University	November 1998
R. Genik	Michigan State University	November 1998
N. Parua	University of Mumbai	November 1998
D. Karmgard	Florida State University	March 1999
A. Gupta	Tata Institute	April 1999
K. Mauritz	Iowa State University	May 1999
J. McDonald	Florida State University	May 1999
K. Frame	Michigan State University	May 1999
E. Smith	University of Oklahoma	May 1999
S. Choi	University of California/Riverside	August 1999
G. Gomez	University of Maryland	August 1999
H. Singh	University of California/Riverside	September 1999
G. Steinbrueck	University of Oklahoma	September 1999
L. Babukhadia	University of Arizona	October 1999
K. Davis	University of Arizona	October 1999
R. Snihur	Northwestern University	December 1999
E. Popkov	University of Notre Dame	April 2000
L. Coney	University of Notre Dame	April 2000
D. Shpakov	SUNY/Stony Brook	July 2000
Z. Casilum	SUNY/Buffalo	October 2000
S. Negroni	Univ. de la Mediterranée	October 2000
B. Knuteson	University of California/Berkeley	December 2000
A. Green	Iowa State University	April 2001
J. Estrada	University of Rochester	July 2001
Y. Kulik	SUNY/Stony Brook	August 2001
L. Dudko	Moscow State University	September 2001
T. Goss	Texas A&M University	September 2001
Q. Xu	University of Michigan	September 2001
A. Abdessalam	LAL, Orsay	October 2001
R. Oliver	LPNHE-Paris	October 2001

C. Hays	Columbia University	December 2001
Y. Huang	University of Michigan	December 2001
C. Lundstedt	University of Nebraska	December 2001
J. Zhou	Iowa State University	December 2001
R. Illingworth	Imperial College	March 2002
A. Patwa	SUNY/Stony Brook	March 2002
F. Deliot	CEA-Saclay	April 2002
M. Ridel	Univ. Paris Sud/LAL	April 2002
H. Zheng	University of Notre Dame	April 2002
D. Bauer	Imperial College	August 2002
A. Besson	Joseph Fourier-Grenoble	October 2002
P. Demine	ISN Grenoble	December 2002
B. Connolly	Florida State University	February 2003
M. Petteni	Imperial College	February 2003
G. Hesketh	University of Manchester	March 2003
S. Jain	Tata Institute	March 2003
F. Villeneuve-Seguier	Univ. de la Méditerranée, Marseille	March 2003
S. Baffioni	Univ. de la Méditerranée, Marseille	April 2003
F. Beaudette	LAL, Orsay	April 2003
C. Hebert	University of Kansas	April 2003
Q. Yu	Louisiana Tech	April 2003
R. Kaur	Panjab University	May 2003
S. Grinstein	Universidad de Buenos Aires	August 2003
F. Canelli	University of Rochester	August 2003
C. Luo	Indiana University	September 2003
M. Gao	Columbia University	September 2003
A. Kupco	Charles University	September 2003
A. Melnitchouk	Brown University	September 2003
O. Peters	Universiteit van Amsterdam	October 2003
Y. Coadou	Uppsala University	October 2003
J. Molina	CBPF/Rio de Janeiro	November 2003
T. Christiansen	LMU, Munich	December 2003
C-H. Han	University of Michigan	December 2003
D. Whiteson	University of California/Berkeley	December 2003
M. Klute	University of Bonn	February 2004
G. Davis	University of Rochester	March 2004
R. Hooper	University of Notre Dame	March 2004
L. Phaf	University of Amsterdam	March 2004
A. Schwartzman	Universidad de Buenos Aires	March 2004
S. Duensing Nelson	University of Nijmegen	April 2004
S. Beauceron	Université Paris VI	May 2004
A. Cothenet	CPPM, Marseille	May 2004
S. Fu	Columbia University	May 2004
M. Hohlfeld	University of Mainz	May 2004
A. Haas	University of Washington	June 2004
T. Anh	Université Paris VI	July 2004
D. Evans	Lancaster University	July 2004
A. Khanov	University of Rochester	July 2004
N. Lahrichi	DAPNIA/Saclay	July 2004
A. Yurkewicz	Michigan State University	August 2004
X. Zhang	University of Oklahoma	August 2004
S. Greder	Strasbourg	October 2004
A. Zabi	LAL, Orsay	October 2004
J. Zhu	University of Maryland	October 2004
A. Askew	Rice University	November 2004
J. Huang	Indiana University	November 2004
R. McCroskey	University of Arizona	November 2004
P. Balm	University of Amsterdam	December 2004
S. Kesisoglou	Brown University	December 2004
S. Fatakia	Boston University	January 2005

W. Fisher	Princeton University	January 2005
E. Nurse	University of Manchester	February 2005
D. Cho	University of Rochester	February 2005
Y. Mutaf	SUNY/Stony Brook	February 2005
T. Golling	University of Bonn	February 2005
K. Black	Boston University	February 2005
C. Barnes	Imperial College London	March 2005
F. Blekman	University of Amsterdam	April 2005
J. Kozminski	Michigan State University	April 2005
E. Busato	Université Paris VI	April 2005
A-C. Le Bihan	Université Louis Pasteur	April 2005
M. Eads	Northern Illinois University	April 2005
N. Xuan	University of Notre Dame	May 2005
M. Das	Louisiana Tech University	May 2005
M. Agelou	Université Paris VI	May 2005
D. Wijngaarden	University of Nijmegen/NIKHEF	June 2005
J-R. Vlimant	Université Paris VI	June 2005
M. Buehler	University of Illinois/Chicago	July 2005
A-M. Magnan	Univ. Joseph Fourier, Grenoble	July 2005
R. Gelhaus	Univ. of California/Riverside	August 2005
X. Song	Northern Illinois University	August 2005
M. Strang	University of Texas/Arlington	August 2005
U. Blumenschein	University of Freiburg	August 2005
M. Binder	LMU/Munich	September 2005
P. Podesta Lerma	CINVESTAV	October 2005
R. Bernhard	University of Zurich	October 2005
J. Gardner	University of Kansas	October 2005
L. Feligioni	Boston University	November 2005
P. Schieferdecker	LMU/Munich	November 2005
K. Chan	University of Rochester	November 2005
P. Mal	Tata Inst. of Fundamental Research	November 2005
T. Bose	Columbia University	December 2005
S. Jabeen	University of Kansas	January 2006
G. Otero y Garzon	University of Illinois, Chicago	March 2006
J. Strandberg	Stockholm University	April 2006
C. Noeding	University of Freiburg	April 2006
T. Edwards	University of Manchester	April 2006
J. Lazoflores	Florida State University	April 2006
N. Makovec	Université Paris XI	May 2006
B. Clement	Université Louis Pasteur, Strasbourg	May 2006
M. Vaupel	University of Wuppertal	May 2006
S. Sengupta	Florida State University	May 2006
A. Quadt	Bonn University	May, 2006
P. Perea	Univ. of California/Riverside	June, 2006
O. Atramentov	Iowa State University	July 2006
V. Lesne	Univ Blaise Pascal, Clermont-Ferrand	July 2006
S. Desai	SUNY, Stony Brook	August 2006
S. A. Uzunyan	Northern Illinois University	August 2006
P. Telford	University of Manchester	August 2006
A. Zatserklyaniy	Northern Illinois University	August 2006
M. Michaut	DAPNIA/SACLAY	October 2006
A. Mendes	CPPM, Marseille	October 2006
D. Kaefer	RWTH Aachen	November 2006
J. Temple	University of Arizona	November 2006
J. Heinmiller	University of Illinois, Chicago	November 2006
S. Burke	University of Arizona	December 2006
L. Sonnenschein	Université Paris VI	December 2006

E-830

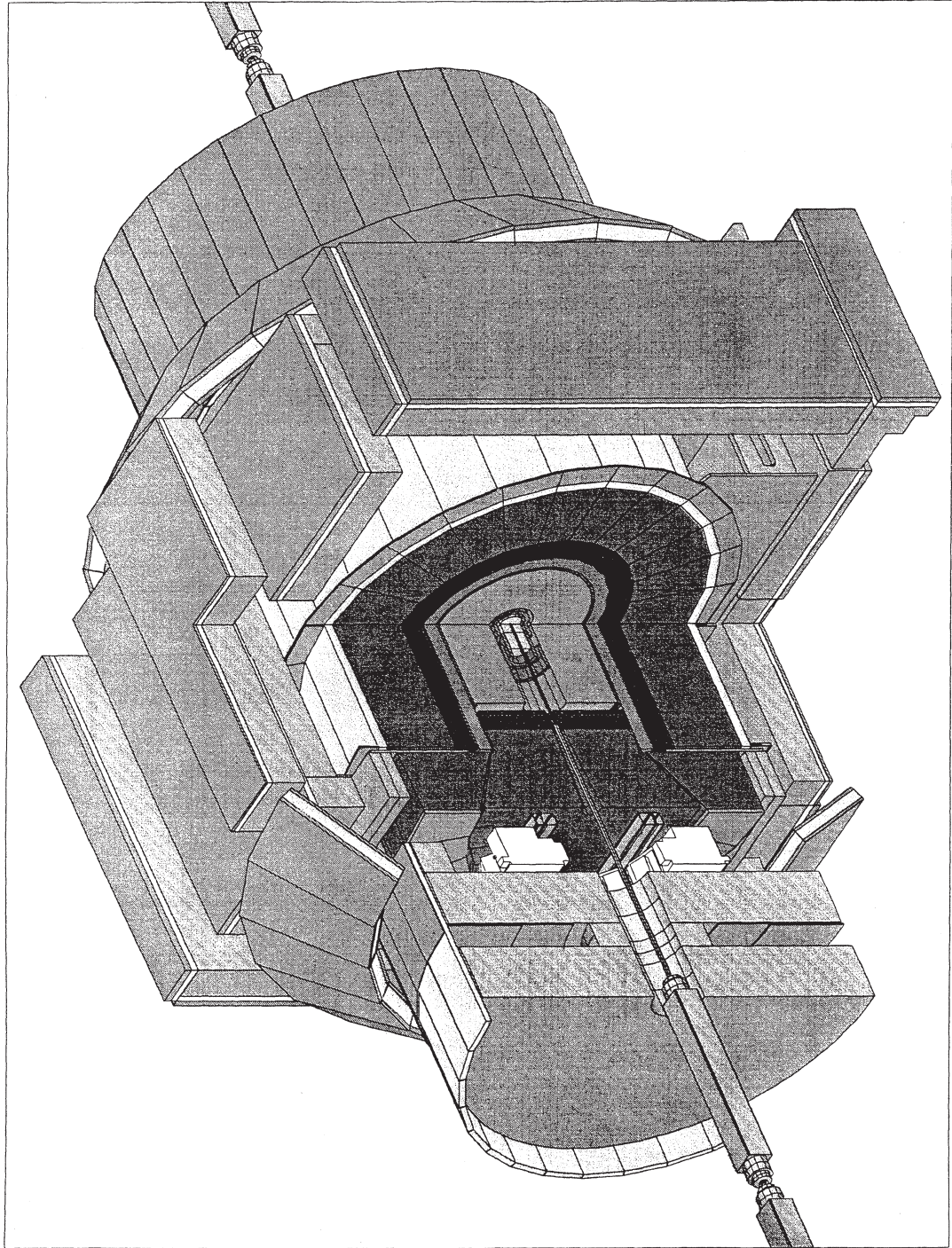

E-830 / 909 / 916 / 924 (Konigsberg / Roser) Collider Detector at Fermilab (CDF)

Academia Sinica (Taiwan), ANL, Barcelona (Spain), Baylor, Bologna (Italy), Brandeis, UC/Davis, UCLA, UC/San Diego, UC/Santa Barbara, Cantabria (Spain), Carnegie Mellon, Chicago, CIEMAT (Spain), Comenius (Slovakia), Duke, Fermilab, Florida, Frascati (Italy), Geneva (Switzerland), Glasgow (United Kingdom), Harvard, Helsinki (Finland), Illinois, IPP/McGill/Toronto (Canada), ITEP (Russia), JINR (Russia), Johns Hopkins, Karlsruhe (Germany), KEK (Japan), Korea Ctr. for HEP (Korea), LBNL, Liverpool (United Kingdom), Michigan, Michigan State, MIT, New Mexico, Northwestern, Ohio State, Okayama (Japan), Osaka City (Japan), Oxford (United Kingdom), Padova (Italy), Paris VI (France), Pennsylvania, Pisa (Italy), Pittsburgh, Purdue, Rochester, Rockefeller, Rome (Italy), Rutgers, Texas A&M, Trieste/Udine (Italy), Tsukuba (Japan), Tufts, Univ. Coll. London (United Kingdom), Waseda (Japan), Wayne State, Wisconsin, Yale

Status: *E-830 - Data-Taking
E-909 - Data-Taking
E-916 - Data-Taking
E-924 - Data-Taking*

The Collider Detector at Fermilab (CDF) is a general purpose detector system designed to explore the physics of 2 TeV proton-antiproton collisions at the Fermilab Tevatron Collider.

I. General Background

The heart of the CDF central detector is a 5.0-meter-long, 1.5-meter-radius, 1.4 Tesla superconducting solenoid. Tracking systems in the magnetic field provide momentum analysis of charged particles. The solenoid is surrounded by scintillator-based calorimeters in the central region covering the angular range 30° to 150° with respect to the Tevatron beams. In the detector which operated until February 1996, two "plug" gas calorimeters in the ends of the solenoid extended the calorimeter coverage down to 10° . In all regions the calorimeters are divided into electromagnetic and hadronic sections and have a projective tower geometry to measure energy flow in fine bins of pseudorapidity and azimuth. Muon chambers are located behind the calorimeters. The original CDF detector has undergone several upgrades. E-775 was the experiment using the CDFI detector, acquiring data during a Tevatron data-taking period from March 1992 until February 1996 (Run I). Section II below describes the detector upgrades for E-775, and some of the major physics results obtained from the data analysis. From 1996 to 2001 there was a second major upgrade of the CDF detector (CDFII). This started commissioning in the summer of 2000, and first data-taking in March 2001 as experiment E-830. The upgrade and status of Run II data-taking are described in Section III below.

II. The CDFI Detector and Tevatron Run I (E-775)

E-775 is the upgraded version of CDF for Collider Runs Ia and Ib. For Run Ia the highlights of the upgrade included:

1. The addition of a 4-layer, 46,000 channel silicon microstrip vertex detector, the SVX. This device was installed around a new 1.5 inch diameter beam pipe and enabled the reconstruction of secondary vertices, opening up a new field of precise b physics measurements and b-tags for top quark identification.
2. A new set of time-projection chambers with 4 cm drift spaces replacing the old 15 cm drift devices in order to cope with higher luminosity.
3. The muon coverage was considerably improved by:
 - a) new chambers and scintillators (CMX) to extend the coverage from pseudorapidity of 0.6 to 1.0; and
 - b) additional steel and new chambers to drastically improve the punchthrough background in the central region.
4. New front-end electronics were added to the gas calorimeters and tracking chambers to cope with higher luminosity. These allowed lower gas gain operation and improved noise performance. The outer regions of the CTC were also equipped with dE/dx readout.
5. The throughput of the data acquisition was considerably improved by adding new event builders and more computing power in Level 3. As a result the output to tape increased from 1.2 to 8 Hz.
6. The offline environment was improved by adding 1000 Mips to the farms and acquiring a 1.2 Tbyte robotic storage device.

For Run Ib, the upgrades included:

1. A new radiation-hard Silicon Vertex Detector.
2. The DAQ bandwidth was increased by adding VME-based scanners and an Ultrahub to connect the readout scanners to the Level 3 processors.
3. New Level 2 processors were installed to increase the speed, flexibility, and power of the trigger.
4. A diffractive spectrometer featuring Roman pots was added.

In Collider Run Ia, CDF rolled into the B0 Collision Hall at the end of March 1992, and the first collisions were seen in May 1992. During Run Ia, the E-775 detector functioned well, taking data at luminosities up to $9 \times 10^{30} \text{cm}^{-2} \text{sec}^{-1}$ with 90 percent livetime and an overall data-taking efficiency of 71 percent. A total data sample of 21.4 pb^{-1} was collected by the end of the run in June 1993.

During Collider Run Ib, the detector continued to function well, taking data at luminosities up to $\sim 20 \times 10^{30} \text{cm}^{-2} \text{sec}^{-1}$ with 90 percent livetime and an

overall data-taking efficiency of about 80 percent. Data-taking began on January 19, 1994, and by February 20, 1996, a total integrated luminosity of $\approx 90 \text{ pb}^{-1}$ had been recorded.

A total of 377 papers on CDF results have been published or submitted, and 382 students have written theses on CDF analyses. Some highlights of the Run I physics program include:

1. First evidence of top quark production followed by its discovery (simultaneously with D0). After the discovery, measurements of the top quark mass, production and decay properties rapidly followed.
2. World-class measurements of the spectroscopy and lifetimes of b quark states, including B^0 mixing, CP violation measurements in the $B^0\bar{B}^0$ sector and the discovery of the B_c meson.
3. Measurement of W mass and width, triboson couplings, and Drell-Yan cross section.
4. Observation of excess over QCD calculations of very high E_T jet production, and other QCD measurements in jet physics, photon physics, and diffractive phenomena.
5. New limits on SUSY particles, Higgs boson, leptoquarks, new gauge bosons, and other exotic states.

III. The CDFII Detector and Tevatron Run II (E-830)

E-830 (also known as CDFII) is the upgraded version of CDF for Collider Run II where the bunch spacing will be 396 ns and the luminosity in excess of $2 \times 10^{32} \text{ cm}^{-2} \text{ sec}^{-1}$. The full scope of the upgrade is described in the Technical Design Report (TDR), available as a Fermilab publication. The highlights of the upgrades for Run IIa include:

1. Replacing the gas calorimeters with scintillating tile-based plug calorimeter extending to $|\eta|$ of 3.6.
2. Replacing the SVX with a five-layer, double-sided SVXII that covers the entire luminous region.
3. Adding two additional layers of silicon detectors (ISL) at larger radii. The combination of the SVXII and ISL will allow precise 3D tracking out to $|\eta|$ of 2.
4. Replacing the CTC with a smaller drift cell version, the COT, which will reduce the drift time to less than the 396 ns bunch spacing.
5. Replacing all the front-end electronics to cope with the shorter bunch spacing. The principal elements include:

- a) pipelined front ends and buffering for L2 decisions resulting in virtually deadtimeless operation; and
 - b) new ASICs for ADCs and TDCs.
6. New trigger system comprising:
- a) all digital trigger;
 - b) new track processor allowing high resolution tracking decisions in L1; and
 - c) Level 2 trigger based on SVXII to allow secondary vertex triggers at L2.
7. Extended muon coverage out to $|\eta|$ of 1.5 including:
- a) new counters and chambers on the muon toroids now moved closer to the interaction region;
 - b) new counters covering the region just outside the CMX; and
 - c) covering missing azimuthal regions in the CMX and central muon coverage.
8. New DAQ components with higher throughput at all levels.
9. Extended offline environment that includes:
- a) code migration toward object-oriented models;
 - b) data handling to cope with petabyte-scale datasets; and
 - c) enhanced computing power in farms.

With the 2 fb^{-1} expected for Run IIa, the anticipated physics program is truly exciting and features:

1. Top quark mass, production, and decay measurements at the few percent level.
2. Observation of CP violation in the b quark sector.
3. Precision mass, lifetime, and spectroscopy measurements of b quark states including B_s mixing and B_c properties.
4. W mass measurement to better than 40 MeV.
5. Jet and photon measurements out to very high E_T .
6. Searches for SUSY particles, Higgs bosons, and other exotic states.

Run IIa began on March 1, 2001 and ended in February 2006. We collected approximately 1.5 fb^{-1} to tape. A total of 110 papers on the Run II CDF results have been submitted or published thus far, and approximately 80 students have received their Ph.D.'s on this data to date. We have not yet completed our analysis on this data sample. We expect that to take another year and result in approximately 50 more papers and another 30 PhDs before we “close the books”.

CDF as E-909

E-909 is a proposal to upgrade the baseline E-830 experiment with the following detectors:

1. An additional single-sided silicon microstrip detector layer positioned very close ($R \sim 1.5 \text{ cm}$) to the beamline.
2. A time-of-flight (TOF) detector consisting of 216 scintillator bars located between the COT and the solenoid.

With the inclusion of these new detectors, CDF significantly increased its physics reach in the area of CP violation in the B sector and B_s mixing. These proposals received Stage II approval by the Fermilab Director in 1999 and are now installed and operating in the CDFII detector.

CDF as E-916

E-916 is a proposal for a diffractive physics program at CDF. The upgrades for this physics include beam shower counters, a Roman pot detector, and mini-plug calorimeters. This proposal was presented to the Fermilab Director and Physics Advisory Committee (PAC) in November 1999 and received Stage I approval by the Fermilab Director in July 2000. The miniplug calorimeters and Roman Pots are now installed and are taking data.

The CDFII detector is now fully operational and collecting physics data for all of our five broad analysis areas: heavy flavor physics (beauty and charm); top quark physics; QCD with jets and photons, diffractive phenomena; electroweak physics with W and Z bosons and di-bosons; searches for new phenomena (SUSY particles, Higgs bosons, etc.). A three-level trigger system used to select the basic physics objects is working well. We make selection cuts on jets, electrons, muons, photons, neutrinos (via missing energy), and beauty and charm hadrons from semileptonic decays and displaced secondary vertices. The latter is accomplished with a level-two silicon vertex trigger (SVT) which has opened a whole new area of heavy flavor physics at CDF. Data-taking efficiency has now reached about 85 percent (recorded integrated luminosity over that delivered.)

The physics goals of the CDFII experiment are broad and fundamental:

- Make tests of the Standard Model via precision studies of top quarks and W bosons.
- Explore the smallest distance scales with high E_T jets and photons.

- Search for supersymmetric particles.
- Search for Higgs Bosons as the source of electroweak symmetry breaking.
- Search for sources of CP violation beyond the Standard Model.
- Search for phenomena predicted by extra dimensions.

Run II has been extremely successful to date. In 2006 alone, CDF was the first to observe B_s mixing, made the world's most precise measurement of the top quark mass, made the world's most precise measurement of the W boson mass to date, was the first to observe WZ di-boson production and the first to observe the Σ_b baryon. These are just a few of the many physics highlights this past year. In addition to those, CDF made a number of precision measurements and tests of the Standard Model and set a wide range of limits on new physics beyond the Standard Model. In 2006, we submitted 48 papers to refereed journals. CDF is now concentrating on publishing the first 1500 pb^{-1} of recorded data, roughly fifteen times that of Run I. The detector is working extremely well, and the collaboration is excited about increasing the data sample sizes. We are now exploring the energy frontier more deeply than ever before.

The Run IIB CDF Detector Upgrade Project (E-924)

The running conditions for Collider Run II originally specified that the CDF detector must be capable of handling peak luminosity up to $2 \times 10^{32} \text{cm}^{-2} \text{sec}^{-1}$, bunch spacing as small as 132 ns, and an integrated luminosity of 2 fb^{-1} . Since that time, the operating plans for the Collider program have changed. Currently, it is anticipated that 8 fb^{-1} will be collected by 2009, and an instantaneous luminosity of $3 \times 10^{32} \text{cm}^{-2} \text{sec}^{-1}$ will be seen at a bunch spacing of 396 ns. These harsher operating conditions motivated a set of upgrades, to handle the increased length of the run and the higher complexity of events in high luminosity operation. Although the scope of this upgrade has evolved with time, we are currently upgrading the following components of the detector:

- The Central Preshower Detector will be replaced by a new device which uses scintillator and photomultiplier tubes.
- Timing information will be read out from all the electromagnetic calorimetry.
- The time-to-digital convertors used for the Central Outer Tracker will be modified to enable quicker reset and readout of the devices.
- The Level 2 trigger infrastructure will be replaced by a more modern system to provide quicker decisions and easier long-term maintenance.
- The Track Trigger, which is used to incorporate the Central Outer Tracker into the Level 1 trigger is being upgraded to include the stereo readout layers in the trigger decision.

- The Event Builder will be upgraded to increase the data throughput and rate of trigger acceptances.
- The Silicon Vertex Trigger will be upgraded to provide finer segmentation and greater speed for trigger decisions.
- Level 3 and data acquisition computers will be upgraded with more modern, and consequently much faster, processors.

The Run IIb project is complete and we have already collected more than 500 pb^{-1} with the detector and trigger in its final configuration. This program will maintain CDF's operation through the high luminosity expected during 2006-2009.

CDF removed its Roman Pot detectors during the February 2006 shutdown (which ended Run IIa), concluding the bulk of its diffractive physics program. With luminosities at that point already above 2×10^{32} on its way to 3×10^{32} , CDF wanted to utilize that space to insert a thicker beam collimator to better protect the silicon during abnormal beam aborts.

Publications

The CDF Detector: An Overview, Nucl. Instr. and Meth. A271, 387 (1988).

Transverse Momentum Distributions of Charged Particles Produced in $\bar{p}p$ Interactions at $\sqrt{s} = 630$ and 1800 GeV , Phys. Rev. Lett. 61, 1819 (1988).

Measurement of the Inclusive Jet Cross Section in $\bar{p}p$ Collisions at $\sqrt{s} = 1.8 \text{ TeV}$, Phys. Rev. Lett. 62, 613 (1989).

Measurement of W-Boson Production in $1.8\text{-TeV } \bar{p}p$ Collisions, Phys. Rev. Lett. 62, 1005 (1989).

Limits on the Masses of Supersymmetric Particles from $1.8 \text{ TeV } \bar{p}p$ Collisions, Phys. Rev. Lett. 62, 1825 (1989).

Dijet Angular Distributions from $\bar{p}p$ Collisions at $\sqrt{s} = 1.8 \text{ TeV}$, Phys. Rev. Lett. 62, 3020 (1989).

Measurement of the Mass and Width of the Z^0 Boson at the Fermilab Tevatron, Phys. Rev. Lett. 63, 720 (1989).

Search for Heavy Stable Particles in $1.8 \text{ TeV } \bar{p}p$ Collisions at the Fermilab Collider, Phys. Rev. Lett. 63, 1447 (1989).

K_S^0 Production in $\bar{p}p$ Interactions at $\sqrt{s} = 630$ and 1800 GeV , Phys. Rev. D, Rapid Communication, 40, 3791 (1989).

A Search for the Top Quark in the Reaction $\bar{p}p \rightarrow e + \text{Jets}$ at $\sqrt{s} = 1.8 \text{ TeV}$, Phys. Rev. Lett. 64, 142 (1990).

A Search for New Heavy Quarks in Electron-Muon Events at the Fermilab Tevatron Collider, Phys. Rev. Lett. 64, 147 (1990).

Measurement of the Ratio $\sigma(W \rightarrow e \nu) / \sigma(Z \rightarrow ee)$ in $\bar{p}p$ Collisions at $\sqrt{s} = 1.8 \text{ TeV}$, Phys. Rev. Lett. 64, 152 (1990).

Two Jet Differential Cross Section in $\bar{p}p$ Collisions at $\sqrt{s} = 1.8 \text{ TeV}$, Phys. Rev. Lett. 64, 157 (1990).

A Measurement of D^* Production in Jets from $\bar{p}p$ Collisions at $\sqrt{s} = 1.8 \text{ TeV}$, Phys. Rev. Lett. 64, 348 (1990).

Jet Fragmentation Properties in $\bar{p}p$ Collisions at $\sqrt{s} = 1.8 \text{ TeV}$, Phys. Rev. Lett. 65, 968 (1990).

- A Measurement of the W Boson Mass, Phys. Rev. Lett. 65, 2243 (1990).
- Search for a Light Higgs Boson at the Tevatron Proton-Antiproton Collider, Phys. Rev. D, Rapid Communication, 41, 1717 (1990).
- The Two Jet Invariant Mass Distribution at $\sqrt{s} = 1.8$ TeV, Phys. Rev. D, Rapid Communication, 41, 1722 (1990).
- Pseudorapidity Distributions of Charged Particles Produced in $\bar{p}p$ Interactions at $\sqrt{s} = 630$ and 1800 GeV, Phys. Rev. D41, 2330 (1990).
- Measurement of the W Boson P_T Distribution in $\bar{p}p$ Collisions at $\sqrt{s} = 1.8$ TeV, Phys. Rev. Lett. 66, 2951 (1991).
- Measurement of the Z Boson P_T Distribution in $\bar{p}p$ Collisions at $\sqrt{s} = 1.8$ TeV, Phys. Rev. Lett. 67, 2937 (1991).
- A Determination of $\sin^2\theta_W$ from the Forward-Backward Asymmetry in $p\bar{p} \rightarrow Z^0 X \rightarrow e^+e^-X$ Interactions at $\sqrt{s} = 1.8$ TeV, Phys. Rev. Lett. 67, 1502 (1991).
- Measurement of the e^+e^- Invariant Mass Distribution in $\bar{p}p$ Collisions at $\sqrt{s} = 1.8$ TeV, Phys. Rev. Lett. 67, 2418 (1991).
- Search for $W' \rightarrow e\nu$ and $W' \rightarrow \mu\nu$ in $\bar{p}p$ Collisions at $\sqrt{s} = 1.8$ TeV, Phys. Rev. Lett. 67, 2609 (1991).
- Measurement of $B^0\bar{B}^0$ Mixing at the Fermilab Tevatron Collider, Phys. Rev. Lett. 67, 3351 (1991).
- A Measurement of the W Boson Mass in 1.8 TeV $\bar{p}p$ Collisions, Phys. Rev. D43, 2070 (1991).
- Top Quark Search in the Electron + Jets Channel in Proton-Antiproton Collisions at $\sqrt{s} = 1.8$ TeV, Phys. Rev. D43, 664 (1991).
- A Measurement of $\sigma(W \rightarrow e\nu)$ and $\sigma(Z^0 \rightarrow e^+e^-)$ in $\bar{p}p$ Collisions at $\sqrt{s} = 1800$ GeV, Phys. Rev. D44, 29 (1991).
- Measurement of QCD Jet Broadening in $\bar{p}p$ Collisions at $\sqrt{s} = 1.8$ TeV, Phys. Rev. D44, 601 (1991).
- A Lower Limit on the Top Quark Mass from Events with Two Leptons in $p\bar{p}$ Collisions at $\sqrt{s} = 1.8$ TeV, Phys. Rev. Lett. 68, 447 (1992).
- Inclusive Jet Cross Section in $\bar{p}p$ Collisions at $\sqrt{s} = 1.8$ TeV, Phys. Rev. Lett. 68, 1104 (1992).
- Lepton Asymmetry in W Decays from $\bar{p}p$ Collisions at $\sqrt{s} = 1.8$ TeV, Phys. Rev. Lett. 68, 1458 (1992).
- A Search for New Gauge Bosons in $\bar{p}p$ Collisions at $\sqrt{s} = 1.8$ TeV, Phys. Rev. Lett. 68, 1463 (1992).
- Measurement of the Isolated Prompt Photon Cross Section in $p\bar{p}$ Collisions at $\sqrt{s} = 1.8$ TeV, Phys. Rev. Lett. 68, 2734 (1992).
- Measurement of the Ratio $\sigma_B(W \rightarrow \tau\nu) / \sigma_B(W \rightarrow e\nu)$ in $p\bar{p}$ Collisions at $\sqrt{s} = 1.8$ TeV, as a Test of Lepton Universality, Phys. Rev. Lett. 68, 3398 (1992).
- A Measurement of the B Meson and b Quark Cross Section at $\sqrt{s} = 1.8$ TeV Using the Exclusive Decay $B^{+-} \rightarrow J/\psi K^{+-}$, Phys. Rev. Lett. 68, 3403 (1992).
- A Measurement of the Production and Muonic Decay Rate of W and Z Bosons in $p\bar{p}$ Collisions at $\sqrt{s} = 1.8$ TeV, Phys. Rev. Lett. 69, 28 (1992).
- Limit on the Rare Decay $W^{+-} \rightarrow \gamma + p^{+-}$ in $p\bar{p}$ Collisions at $\sqrt{s} = 1.8$ TeV, Phys. Rev. Lett. 69, 2160 (1992).
- The Dijet Angular Distribution at $\sqrt{s} = 1.8$ TeV, Phys. Rev. Lett. 69, 2897 (1992).
- Search for Squarks and Gluinos from $p\bar{p}$ Collisions at $\sqrt{s} = 1.8$ TeV, Phys. Rev. Lett. 69, 3439 (1992).

Inclusive J/ψ , ψ' and b-Quark Production in $\bar{p}p$ Collisions at $\sqrt{s} = 1.8$ TeV, Phys. Rev. Lett. 69, 3704 (1992).

Topology of Three Jet Events in $\bar{p}p$ Collisions at $\sqrt{s} = 1.8$ TeV, Phys. Rev. D45, 1448 (1992).

Properties of Events with Large Total Transverse Energy Produced in Proton-Antiproton Collisions at $\sqrt{s} = 1.8$ TeV, Phys. Rev. D45, 2249 (1992).

A Limit on the Top Quark Mass from Proton-Antiproton Collisions at $\sqrt{s} = 1800$ GeV, Phys. Rev. D45, 3921 (1992).

Limits on the Production of Massive Stable Charged Particles, Phys. Rev. D46, R1889 (1992).

A Measurement of Jet Shapes in $\bar{p}p$ Collisions at $\sqrt{s} = 1.8$ TeV, Phys. Rev. Lett. 70, 713 (1993).

Search for $\Lambda_b \rightarrow J/\psi \Lambda^0$ in $\bar{p}p$ Collisions at $\sqrt{s} = 1.8$ TeV, Phys. Rev. D47, R2639 (1993).

Comparison of Jet Production in $\bar{p}p$ Collisions at $\sqrt{s} = 546$ and 1800 GeV, Phys. Rev. Lett. 70, 1376 (1993).

Measurement of the Cross Section for Production of Two Isolated Prompt Photons in $\bar{p}p$ Collisions at $\sqrt{s} = 1.8$ TeV, Phys. Rev. Lett. 70, 2232 (1993).

A Measurement of Jet Multiplicity in W Events Produced in $\bar{p}p$ Collisions at $\sqrt{s} = 1.8$ TeV, Phys. Rev. Lett. 70, 4042 (1993).

A Study of Four-Jet Events and Evidence for Double Parton Interactions in $\bar{p}p$ Collisions at $\sqrt{s} = 1.8$ TeV, Phys. Rev. D47, 4857 (1993).

A Measurement of the Bottom Quark Production Cross Section Using Semileptonic Decay Electrons in $\bar{p}p$ Collisions at $\sqrt{s} = 1.8$ TeV, Phys. Rev. Lett. 71, 500 (1993).

Measurement of the Dijet Mass Distribution in $\bar{p}p$ Collisions at $\sqrt{s} = 1.8$ TeV, Phys. Rev. D48, 998 (1993).

A Prompt Photon Cross Section Measurement in $\bar{p}p$ Collisions at $\sqrt{s} = 1.8$ TeV, Phys. Rev. D48, 2998 (1993).

The Center-of-Mass Angular Distribution from Prompt Photons Produced in $\bar{p}p$ Collisions at $\sqrt{s} = 1.8$ TeV, Phys. Rev. Lett. 71, 679 (1993).

Observation of the Decay $B_s^0 \rightarrow J/\psi \phi$ in $\bar{p}p$ Collisions at $\sqrt{s} = 1.8$ TeV, Phys. Rev. Lett. 71, 1685 (1993).

A Measurement of the Bottom Quark Production Cross Section in 1.8 TeV $\bar{p}p$ Collisions Using Muons from b-Quark Decays, Phys. Rev. Lett. 71, 2396 (1993).

Search for Quark Compositeness, Axiguons and Heavy Particles Using the Dijet Invariant Mass Spectrum Observed in $\bar{p}p$ Collisions, Phys. Rev. Lett. 71, 2542 (1993).

Inclusive χ_c and b-Quark Production in $\bar{p}p$ Collisions at $\sqrt{s} = 1.8$ TeV, Phys. Rev. Lett. 71, 2537 (1993).

A Search for First-Generation Leptoquarks in $\bar{p}p$ Collisions at $\sqrt{s} = 1.8$ TeV at CDF, Phys. Rev. D48, R3939 (1993).

Measurement of the Average Lifetime of B-hadrons Produced in $\bar{p}p$ Collisions at $\sqrt{s} = 1.8$ TeV, Phys. Rev. Lett. 71, 3421 (1993).

Measurement of Drell-Yan Electron and Muon Pair Differential Cross-Sections in $\bar{p}p$ Collisions at $\sqrt{s} = 1.8$ TeV, Phys. Rev. D49, R1 (1994).

Evidence for Top Quark Production in $\bar{p}p$ Collisions at $\sqrt{s} = 1.8$ TeV, Phys. Rev. D50, 2966 (1994).

A Measurement of the B Meson and b Quark Cross Sections at $\sqrt{s} = 1.8$ TeV Using the Exclusive Decay $B^0 \rightarrow J/\psi K^{*}(892)^0$, Phys. Rev. D50, 4252 (1994).

Measurement of Small Angle Antiproton-Proton Elastic Scattering at $\sqrt{s} = 546$ and 1800 GeV, Phys. Rev. D50, 5518 (1994).

- Measurement of the $\bar{p}p$ Single Diffraction Dissociation at $\sqrt{s} = 546$ and 1800 GeV, Phys. Rev. D50, 5535 (1994).
- Measurement of the Antiproton-Proton Total Cross Section at $\sqrt{s} = 546$ and 1800 GeV, Phys. Rev. D50, 5550 (1994).
- A Search for the Top Quark Decaying to a Charged Higgs in $\bar{p}p$ Collisions at $\sqrt{s} = 1.8$ TeV, Phys. Rev. Lett. 72, 1977 (1994).
- Search for Excited Quarks in $\bar{p}p$ Collisions at $\sqrt{s} = 1.8$ TeV, Phys. Rev. Lett. 72, 3004 (1994).
- Measurement of the B^+ and B^0 Meson Lifetimes, Phys. Rev. Lett. 72, 3456 (1994).
- Measurement of the Ratio $\sigma(B \rightarrow e\nu) / \sigma(B \rightarrow e^+e^-)$ in $\bar{p}p$ Collisions at $\sqrt{s} = 1.8$ TeV, Phys. Rev. Lett. 73, 220 (1994).
- Evidence for Top Quark Production in $\bar{p}p$ Collisions at $\sqrt{s} = 1.8$ TeV, Phys. Rev. Lett. 73, 225 (1994).
- Evidence for Color Coherence in $\bar{p}p$ Collisions at $\sqrt{s} = 1.8$ TeV, Phys. Rev. D50, 5562 (1994).
- W Boson + Jet Angular Distribution in $\bar{p}p$ Collisions at $\sqrt{s} = 1.8$ TeV, Phys. Rev. Lett. 73, 2296 (1994).
- A Precision Measurement of the Prompt Photon Cross Section in $\bar{p}p$ Collisions at $\sqrt{s} = 1.8$ TeV, Phys. Rev. Lett. 73, 2662 (1994).
- Search for the Top Quark Decaying to a Charged Higgs Boson in $\bar{p}p$ Collisions at $\sqrt{s} = 1.8$ TeV, Phys. Rev. Lett. 73, 2667 (1994).
- A Direct Measurement of the W Boson Width, Phys. Rev. Lett. 74, 341 (1995).
- The Charge Asymmetry in W-Boson Decays Produced in $\bar{p}p$ Collisions at $\sqrt{s} = 1.8$ TeV, Phys. Rev. Lett. 74, 850 (1995).
- Observation of Rapidity Gaps in $\bar{p}p$ Collisions at 1.8 TeV, Phys. Rev. Lett. 74, 855 (1995).
- Measurement of W-Photon Couplings with CDF in $\bar{p}p$ Collisions at $\sqrt{s} = 1.8$ TeV, Phys. Rev. Lett. 74, 1936 (1995).
- Limits on Z-Photon Couplings from $\bar{p}p$ Interactions at $\sqrt{s} = 1.8$ TeV, Phys. Rev. Lett. 74, 1941 (1995).
- Search for New Gauge Bosons Decaying into Dielectrons in $\bar{p}p$ Collisions at $\sqrt{s} = 1.8$ TeV, Phys. Rev. D51, 949 (1995).
- Observation of Top Quark Production in $\bar{p}p$ Collisions with CDF Detector at Fermilab, Phys. Rev. Lett. 74, 2626 (1995).
- Search for Charged Bosons Heavier than the W in $\bar{p}p$ Collisions at $\sqrt{s} = 1800$ GeV, Phys. Rev. Lett. 74, 2900 (1995).
- Kinematical Evidence for Top Pair Production in W + Multijet Events in $\bar{p}p$ Collisions at $\sqrt{s} = 1.8$ TeV, Phys. Rev. D51, 4623 (1995).
- Search for New Particles Decaying to Dijets in $\bar{p}p$ Collisions at $\sqrt{s} = 1.8$ TeV, Phys. Rev. Lett. 74, 3538 (1995).
- Measurement of the B_s Meson Lifetime, Phys. Rev. Lett. 74, 4988 (1995).
- A Measurement of the Ratio $\sigma(B(\bar{p}p \rightarrow W \rightarrow e\nu) / \sigma(B(\bar{p}p \rightarrow Z^0 \rightarrow ee)$ in $\bar{p}p$ Collisions at $\sqrt{s} = 1800$ GeV, Phys. Rev. D52, 2624 (1995).
- Measurement of the W Boson Mass, Phys. Rev. Lett. 75, 11 (1995).
- Properties of High-Mass Multijet Events at the Fermilab Proton-Antiproton Collider, Phys. Rev. Lett. 75, 608 (1995).
- Search for Squarks and Gluinos Via Radiative Decays of Neutralinos in Proton-Antiproton Collisions at $\sqrt{s} = 1.8$ TeV, Phys. Rev. Lett. 75, 613 (1995).

- Identification of Top Quarks Using Kinematical Variables, Phys. Rev. D52, R2605 (1995).
- Measurement of the W Boson Mass, Phys. Rev. D52, 4784 (1995).
- A Search for Second Generation Leptoquarks in $p\bar{p}$ Collisions at $\sqrt{s} = 1.8$ TeV, Phys. Rev. Lett. 75, 1012 (1995).
- Limits on WWZ and WW γ Couplings from WW and WZ Production in $p\bar{p}$ Collisions at $\sqrt{s} = 1.8$ TeV, Phys. Rev. Lett. 75, 1017 (1995).
- Measurement of the B Meson Differential Cross-Section, $d\sigma/d_{pT}$, in $p\bar{p}$ Collisions at $\sqrt{s} = 1.8$ TeV, Phys. Rev. Lett. 75, 1451 (1995).
- Measurement of the Polarization in the Decays $B_d \rightarrow J/\psi K^{*0}$ and $B_s \rightarrow J/\psi\phi$, Phys. Rev. Lett. 75, 3068 (1995).
- Study of $t\bar{t}$ Production in $p\bar{p}$ Collisions Using Total Transverse Energy, Phys. Rev. Lett. 75, 3997 (1995).
- Υ Production in $p\bar{p}$ Collisions at $\sqrt{s} = 1.8$ TeV, Phys. Rev. Lett. 75, 4358 (1995).
- Measurement of Correlated $\mu\bar{b}$ Jet Cross Sections in $p\bar{p}$ Collisions at $\sqrt{s} = 1.8$ TeV, Phys. Rev. D53, 1051 (1996).
- Search for Gluino and Squark Cascade Decays at the Fermilab Tevatron Collider, Phys. Rev. Lett. 76, 2006 (1996).
- Reconstruction of $B^0 \rightarrow J/\psi K_s^0$ and Measurement of Ratios of Branching Ratios Involving $B \rightarrow J/\psi K^{(*)}$, Phys. Rev. Lett. 76, 2015 (1996).
- Search for the Rare Decay $W^\pm \rightarrow \pi^\pm + \gamma$, Phys. Rev. Lett. 76, 2852 (1996).
- Measurement of $\sigma_B(W \rightarrow e\nu)$ and $\sigma_B(Z^0 \rightarrow e^+e^-)$ in $p\bar{p}$ Collisions at $\sqrt{s} = 1.8$ TeV, Phys. Rev. Lett. 76, 3070 (1996).
- Measurement of the Mass of the B_s^0 Meson, Phys. Rev. D53, 3496 (1996).
- Search for Chargino-Neutralino Production in $p\bar{p}$ Collisions at $\sqrt{s} = 1.8$ TeV, Phys. Rev. Lett. 76, 4307 (1996).
- Search for Charged Higgs Decays of the Top Quark Using Hadronic Tau Decays, Phys. Rev. D54, 735 (1996).
- Measurement of the B^- and \bar{B}^0 Meson Lifetimes Using Semileptonic Decays, Phys. Rev. Lett. 76, 4462 (1996).
- Search for Flavor-Changing Neutral Current B Meson Decays in $p\bar{p}$ Collisions at $\sqrt{s} = 1.8$ TeV, Phys. Rev. Lett. 76, 4675 (1996).
- Inclusive Jet Cross Section in $p\bar{p}$ Collisions at $\sqrt{s} = 1.8$ TeV, Phys. Rev. Lett. 77, 438 (1996).
- Properties of Jets in Z Boson Events from 1.8 TeV $p\bar{p}$ Collisions, Phys. Rev. Lett. 77, 448 (1996).
- Measurement of Λ_b^0 Lifetime Using $\Lambda_b^0 \rightarrow \Lambda_c^+ l^- \bar{\nu}$, Phys. Rev. Lett. 77, 1439 (1996).
- Forward-Backward Charge Asymmetry of Electron Pairs Above the Z^0 Pole, Phys. Rev. Lett. 77, 2616 (1996).
- Measurement of the Lifetime of the B_s^0 Meson Using the Exclusive Decay Mode $B_s^0 \rightarrow J/\psi\phi$, Phys. Rev. Lett. 77, 1945 (1996).
- Further Properties of High-Mass Multijet Events at the Fermilab Proton-Antiproton Collider, Phys. Rev. D54, 4221 (1996).
- Ratios of Bottom Meson Branching Fractions Involving J/ψ Mesons and Determination of b Quark Fragmentation Fractions, Phys. Rev. D54, 6596 (1996).
- Measurement of the $\gamma + D^{*\pm}$ Cross Section in $p\bar{p}$ Collisions at $\sqrt{s} = 1.8$ TeV, Phys. Rev. Lett. 77, 5005 (1996).
- Measurement of Dijet Angular Distributions at CDF, Phys. Rev. Lett. 77, 5336 (1996).

- Measurement of the Branching Fraction $B(B_u^+ \rightarrow J/\psi\pi^+)$ and Search for $B_c^+ \rightarrow J/\psi\pi^+$, Phys. Rev. Lett. 77, 5176 (1996).
- Observation of $\Lambda_b^0 \rightarrow J/\psi\Lambda$ at the Fermilab Proton-Antiproton Collider, Phys. Rev. D55, 1142 (1997).
- Measurement of $b\bar{b}$ Production Correlations, $B^0\bar{B}^0$ Mixing, and a Limit on ϵ_B in $p\bar{p}$ Collisions at $\sqrt{s} = 1.8$ TeV, Phys. Rev. D55, 2546 (1997).
- Observation of Diffractive W-Boson Production at the Tevatron, Phys. Rev. Lett. 78, 2698 (1997).
- Search for Third Generation Leptoquarks in $p\bar{p}$ Collisions at $\sqrt{s} = 1.8$ TeV, Phys. Rev. Lett. 78, 2906 (1997).
- Evidence for W^+W^- Production in $p\bar{p}$ Collisions at $\sqrt{s} = 1.8$ TeV, Phys. Rev. Lett. 78, 4536 (1997).
- Search for Charged Higgs Decays of the Top Quark Using Hadronic Decays of the Tau Lepton, Phys. Rev. Lett. 79, 357 (1997).
- Search for New Particles Decaying to Dijets at CDF, Phys. Rev. D55, Rapid Communications, R5263 (1997).
- J/ψ and $\psi(2S)$ Production in $p\bar{p}$ Collisions at $\sqrt{s} = 1.8$ TeV, Phys. Rev. Lett. 79, 572 (1997).
- Production of J/ψ Mesons from χ_c Meson Decays in $p\bar{p}$ Collisions at $\sqrt{s} = 1.8$ TeV, Phys. Rev. Lett. 79, 578 (1997).
- Measurement of Double Parton Scattering in $p\bar{p}$ Collisions at $\sqrt{s} = 1.8$ TeV, Phys. Rev. Lett. 79, 584 (1997).
- Search for Gluinos and Squarks at the Fermilab Tevatron Collider, Phys. Rev. D56, Rapid Communications, R1357 (1997).
- First Observation of the All Hadronic Decay of $t\bar{t}$ Pairs, Phys. Rev. Lett. 79, 1992 (1997).
- Search for New Gauge Bosons Decaying into Dileptons in $p\bar{p}$ Collisions at $\sqrt{s} = 1.8$ TeV, Phys. Rev. Lett. 79, 2192 (1997).
- Limits on Quark-Lepton Compositeness Scales from Dileptons Produced in 1.8 TeV $p\bar{p}$ Collisions, Phys. Rev. Lett. 79, 2198 (1997).
- Measurement of Diffractive Dijet Production at the Tevatron, Phys. Rev. Lett. 79, 2636 (1997).
- Properties of Six-Jet Events with Large Six-Jet Mass at the Fermilab Proton-Antiproton Collider, Phys. Rev. D56, 2532 (1997).
- Double Parton Scattering in $p\bar{p}$ Collisions at $\sqrt{s} = 1.8$ TeV, Phys. Rev. D56, 3811 (1997).
- The $\mu\tau$ and $e\tau$ Decays of Top Quark Pairs Produced in $p\bar{p}$ Collisions at $\sqrt{s} = 1.8$ TeV, Phys. Rev. Lett. 79, 3585 (1997).
- Search for New Particles Decaying into $b\bar{b}$ and Produced in Association with W Bosons Decaying into $e\nu$ or $\mu\nu$ at the Tevatron, Phys. Rev. Lett. 79, 3819 (1997).
- Search for First Generation Leptoquark Pair Production in $p\bar{p}$ Collisions at $\sqrt{s} = 1.8$ TeV Phys. Rev. Lett. 79, 4327 (1997).
- Properties of Jets in W Boson Events from 1.8 TeV $p\bar{p}$ Collisions, Phys. Rev. Lett. 79, 4760 (1997).
- Properties of Photon Plus Two-Jet Events in $p\bar{p}$ Collisions at $\sqrt{s} = 1.8$ TeV, Phys. Rev. D57, 67 (1998).
- Dijet Production by Color-Singlet Exchange at the Fermilab Tevatron, Phys. Rev. Lett. 80, 1156 (1998).
- The Jet Pseudorapidity Distribution in Direct Photon Events in $p\bar{p}$ Collisions at $\sqrt{s} = 1.8$ TeV, Phys. Rev. D57, 1359 (1998).

Measurement of the $B^0\bar{B}^0$ Oscillation Frequency in $p\bar{p}$ Collisions using π -B Meson Charge-Flavor Correlations at $\sqrt{s} = 1.8$ TeV, Phys. Rev. Lett. 80, 2057 (1998).

Search for Flavor-Changing Neutral Current Decays of the Top Quark in $p\bar{p}$ Collisions at $\sqrt{s} = 1.8$ TeV, Phys. Rev. Lett. 80, 2525 (1998).

Measurement of the Top Quark Mass, Phys. Rev. Lett. 80, 2767 (1998).

Measurement of the $t\bar{t}$ Production Cross Section in $p\bar{p}$ Collisions at $\sqrt{s} = 1.8$ TeV, Phys. Rev. Lett. 80, 2773 (1998).

Measurement of the Top Quark Mass and $t\bar{t}$ Production Cross Section from Dilepton Events at the Collider Detector at Fermilab, Phys. Rev. Lett. 80, 2779 (1998).

Measurement of the Differential Cross Section for Events with Large Total Transverse Energy in $p\bar{p}$ Collisions at $\sqrt{s} = 1.8$ TeV, Phys. Rev. Lett. 80, 3461 (1998).

Measurement of B Hadron Lifetimes Using J/ψ Final States at CDF, Phys. Rev. D57, 5382 (1998).

Observation of Hadronic W Decays in $t\bar{t}$ Events with the Collider Detector at Fermilab, Phys. Rev. Lett. 80, 5720 (1998).

Search for the Decays $B_d^0 \rightarrow \mu^+\mu^-$ and $B_s^0 \rightarrow \mu^+\mu^-$ in $p\bar{p}$ Collisions at $\sqrt{s} = 1.8$ TeV, Phys. Rev. D57, R3811 (1998).

Searches for New Physics in Diphoton Events in $p\bar{p}$ Collisions at $\sqrt{s} = 1.8$ TeV, Phys. Rev. Lett. 81, 1791 (1998).

Search for Chargino-Neutralino Associated Production at the Fermilab Tevatron Collider, Phys. Rev. Lett. 80, 5275 (1998).

Search for the Rare Decay $W^\pm \rightarrow \pi^\pm + \gamma$ in Proton-Antiproton Collisions at $\sqrt{s} = 1.8$ TeV, Phys. Rev. D58, Rapid Communications, 031101 (1998).

Observation of $B^+ \rightarrow \psi(2S)K^+$ and $B^0 \rightarrow \psi(2S)K^*(892)^0$ Decays and Measurements of B-Meson Branching Fractions into J/ψ and $\psi(2S)$ Final States, Phys. Rev. D58, 072001 (1998).

Search for the Rare Decay $W^\pm \rightarrow D_S^\pm \gamma$ in Proton-Antiproton Collisions at $\sqrt{s} = 1.8$ TeV, Phys. Rev. D58, 091101 (1998).

Observation of B_c Mesons in $p\bar{p}$ Collisions at $\sqrt{s} = 1.8$ TeV, Phys. Rev. D58, 112004 (1998).

Measurement of the $\sigma(W + \geq 1 \text{ Jet})/\sigma(W)$ Cross Section Ratio from $p\bar{p}$ Collisions at $\sqrt{s} = 1.8$ TeV, Phys. Rev. Lett 81, 1367 (1998).

Search for Long-Lived Parents of Z^0 Bosons in $p\bar{p}$ Collisions at $\sqrt{s} = 1.8$ TeV, Phys. Rev. D58, Rapid Communications, 051102 (1998).

Observation of the B_c Meson in $p\bar{p}$ Collisions at $\sqrt{s} = 1.8$ TeV, Phys. Rev. Lett. 81, 2432 (1998).

Measurement of the B^- and \bar{B}^0 Meson Lifetimes Using Semileptonic Decays, Phys. Rev. D58, 092002 (1998).

Measurement of the CP-Violation Parameter $\sin(2\beta)$ in $B_d^0/\bar{B}_d^0 \rightarrow J/\psi K_s^0$ Decays, Phys. Rev. Lett. 81, 4806 (1998).

Search for Second Generation Leptoquarks in the Dimuon Plus Dijet Channel of $p\bar{p}$ Collisions at $\sqrt{s} = 1.8$ TeV, Phys. Rev. Lett. 81, 4806 (1998).

Search for Higgs Bosons Produced in Association with a Vector Boson in $p\bar{p}$ Collisions at $\sqrt{s} = 1.8$ TeV, Phys. Rev. Lett. 81, 5748 (1998).

Events with a Rapidity Gap Between Jets in $p\bar{p}$ Collisions at $\sqrt{s} = 630$ GeV, Phys. Rev. Lett. 81, 5278 (1998).

Search for the Decays $B_s^0, B_d^0 \rightarrow e^\pm \mu^\pm$ and Pati-Salam Leptoquarks, Phys. Rev. Lett. 81, 5742 (1998).

- Measurement of the Top Quark Mass with the Collider Detector at Fermilab, Phys. Rev. Lett. 82, 281 (1999).
- Search for New Particles Decaying to $b\bar{b}$ in $p\bar{p}$ Collisions at $\sqrt{s} = 1.8$ TeV, Phys. Rev. Lett. 82, 2038 (1999).
- Measurement of the $B_d^0 - \bar{B}_d^0$ Flavor Oscillation Frequency and Study of Same Side Tagging of B Mesons in $p\bar{p}$ Collisions, Phys. Rev. D59, 032001 (1999).
- Measurement of the B_s^0 Meson Lifetime Using Semileptonic Decays, Phys. Rev. D59, 034021 (1999).
- Measurement of Z^0 and Drell-Yan Production Cross Section Using Dimuons in $p\bar{p}$ Collisions at $\sqrt{s} = 1.8$ TeV, Phys. Rev. D59, 052002 (1999).
- Kinematics of $t\bar{t}$ Events at CDF, Phys. Rev. D59, 092001 (1999).
- Searches for New Physics in Diphoton Events in $p\bar{p}$ Collisions at $\sqrt{s} = 1.8$ TeV, Phys. Rev. D59, 092002 (1999).
- Search for Third-Generation Leptoquarks from Technicolor Models in $p\bar{p}$ Collisions at $\sqrt{s} = 1.8$ TeV, Phys. Rev. Lett. 82, 3206 (1999).
- A Search for $B_s^0 - \bar{B}_s^0$ Oscillations Using the Semileptonic Decay $B_s^0 \rightarrow \phi l^+ X \nu$, Phys. Rev. Lett. 82, 3576 (1999).
- Measurement of the $B_d^0 - \bar{B}_d^0$ Oscillation Frequency Using Dimuon Data in $p\bar{p}$ Collisions at $\sqrt{s} = 1.8$ TeV, Phys. Rev. D60, 051101 (1999).
- Search for R-parity Violating Supersymmetry Using Like-Sign Dielectrons in $p\bar{p}$ Collisions at $\sqrt{s} = 1.8$ TeV, Phys. Rev. Lett. 83, 2133 (1999).
- Measurement of $B^0 - \bar{B}^0$ Flavor Oscillation Frequency Using Jet-Charge and Lepton Flavor Tagging in $p\bar{p}$ Collisions at $\sqrt{s} = 1.8$ TeV, Phys. Rev. D60, 072003 (1999).
- Measurement of the Associated $\gamma + \mu^\pm$ Production Cross Section in $p\bar{p}$ Collisions at $\sqrt{s} = 1.8$ TeV, Phys. Rev. D60, 092003 (1999).
- A Measurement of b Quark Fragmentation Fractions in the Production of Strange and Light B Mesons in $p\bar{p}$ Collisions at $\sqrt{s} = 1.8$ TeV, Phys. Rev. D60, 092005 (1999).
- Search for a Technicolor ω_T Particle in Events with a Photon and a b-quark Jet at CDF, Phys. Rev. Lett. 83, 3124 (1999).
- Search for the Flavor-Changing Neutral Current Decays $B^+ \rightarrow \mu^+ \mu^- K^+$ and $B^0 \rightarrow \mu^+ \mu^- K^{*0}$, Phys. Rev. Lett. 83, 3378 (1999).
- Measurement of the $B^0 - \bar{B}^0$ Oscillation Frequency using $l^- D^{*+}$ Pairs and Lepton Flavor Tags, Phys. Rev. D60, 112004 (1999).
- Measurement of the Helicity of W Bosons in Top Quark Decays, Phys. Rev. Lett. 84, 216 (2000).
- Observation of Diffractive b-quark Production at the Fermilab Tevatron, Phys. Rev. Lett. 84, 232 (2000).
- Measurement of $b\bar{b}$ Rapidity Correlations in $p\bar{p}$ Collisions at $\sqrt{s} = 1.8$ TeV, Phys. Rev. D61, 032001 (2000).
- Search for a Fourth-Generation Quark More Massive than the Z^0 Boson in $p\bar{p}$ Collisions at $\sqrt{s} = 1.8$ TeV, Phys. Rev. Lett. 84, 835 (2000).
- The Transverse Momentum and Total Cross Section of e^+e^- Pairs in the Z-boson Region from $p\bar{p}$ Collisions at $\sqrt{s} = 1.8$ TeV, Phys. Rev. Lett. 84, 845 (2000).
- Search for Color Singlet Technicolor Particles in $p\bar{p}$ Collisions at $\sqrt{s} = 1.8$ TeV, Phys. Rev. Lett. 84, 1110 (2000).
- Measurement of b Quark Fragmentation Fractions in $p\bar{p}$ Collisions at $\sqrt{s} = 1.8$ TeV, Phys. Rev. Lett. 84, 1663 (2000).

- Production of $\Upsilon(1S)$ Mesons from χ_b Decays in $p\bar{p}$ Collisions at $\sqrt{s} = 1.8$ TeV, Phys. Rev. Lett. 84, 2094 (2000).
- Search for Scalar Top Quark Production in $p\bar{p}$ Collisions at $\sqrt{s} = 1.8$ TeV, Phys. Rev. Lett. 84, 5273 (2000).
- Search for Scalar Top and Scalar Bottom Quarks in $p\bar{p}$ Collisions at $\sqrt{s} = 1.8$ TeV, Phys. Rev. Lett. 84, 5704 (2000).
- Search for a W' Boson Via the Decay Mode $W' \rightarrow \mu\nu\mu$ in 1.8 TeV $p\bar{p}$ Collisions, Phys. Rev. Lett. 84, 5716 (2000).
- A Measurement of $\sin 2\beta$ from $B \rightarrow J/\psi K_s^0$ with the CDF Detector, Phys. Rev. D61, 072005 (2000).
- A Measurement of the Differential Dijet Mass Cross Section in $p\bar{p}$ Collisions at $\sqrt{s} = 1.8$ TeV, Phys. Rev. D61, 091101 (2000).
- Search for the Charged Higgs boson in the Decays of Top Quark Pairs in the $e\tau$ and $\mu\tau$ Channels at $\sqrt{s} = 1.8$ TeV, Phys. Rev. D62, 12004 (2000).
- Limits on Gravitino Production and New Processes with Large Missing Transverse Energy in $p\bar{p}$ Collisions at $\sqrt{s} = 1.8$ TeV, Phys. Rev. Lett. 85, 1378 (2000).
- Search for Second and Third Generation Leptoquarks Including Production Via Technicolor Interactions in $p\bar{p}$ Collisions at $\sqrt{s} = 1.8$ TeV, Phys. Rev. Lett. 85, 2056 (2000).
- Search for New Particles Decaying to $t\bar{t}$ in $p\bar{p}$ Collisions at $\sqrt{s} = 1.8$ TeV, Phys. Rev. Lett. 85, 2062 (2000).
- Measurement of J/ψ and $\psi(2S)$ Polarization in $p\bar{p}$ Collisions at $\sqrt{s} = 1.8$ TeV, Phys. Rev. Lett. 85, 2886 (2000).
- Direct Measurement of the W Boson Width in $p\bar{p}$ Collisions at $\sqrt{s} = 1.8$ TeV, Phys. Rev. Lett. 85, 3347 (2000).
- Dijet Production by Double Pomeron Exchange at the Fermilab Tevatron, Phys. Rev. Lett. 85, 4215 (2000).
- Measurement of the Decay Amplitudes of $B^0 \rightarrow J/\psi K^{*0}$ and $B_s^0 \rightarrow J/\psi \phi$ Decays, Phys. Rev. Lett. 85, 4668 (2000).
- Measurement of $d\sigma/dy$ for High Mass Drell-Yan e^+e^- Pairs from $p\bar{p}$ Collisions at $\sqrt{s} = 1.8$ TeV, Phys. Rev. D63, Rapid Communications, 011101 (2000).
- Measurement of the Top Quark Mass with the Collider Detector at Fermilab, Phys. Rev. D63, 032003 (2001).
- Tests of Enhanced Leading Order QCD in W Boson Plus Jets Events from 1.8 TeV $p\bar{p}$ Collisions, Phys. Rev. D63, 072003 (2001).
- Search for Supersymmetric Partner of the Top Quark in $p\bar{p}$ Collisions at $\sqrt{s} = 1.8$ TeV, Phys. Rev. D63, 091101 (2001).
- Measurement of the Two-Jet Differential Cross Section in $p\bar{p}$ Collisions at $\sqrt{s} = 1800$ GeV, Phys. Rev. D64, 012001 (2001).
- First Measurement of the Ratio $(t \rightarrow Wb)/B(t \rightarrow Wq)$ and Associated Limit on the CKM Element $|V_{tb}|$, Phys. Rev. Lett. 86, 3233 (2001).
- Production of χ_{c1} and χ_{c2} in $p\bar{p}$ Collisions at $\sqrt{s} = 1.8$ TeV, Phys. Rev. Lett. 86, 3963 (2001).
- Measurement of the Inclusive Jet Cross Section in $p\bar{p}$ Collisions at $\sqrt{s} = 1.8$ TeV, Phys. Rev. D64, 032001 (2001).
- Measurement of the $t\bar{t}$ Production Cross Section in $p\bar{p}$ Collisions at $\sqrt{s} = 1.8$ TeV, Phys. Rev. D64, 032002 (2001).
- Measurement of the W Boson Mass with the Collider Detector at Fermilab, Phys. Rev. D64, 052001 (2001).

- Observation of Orbitally Excited B Mesons in $p\bar{p}$ Collisions at $\sqrt{s} = 1.8$ TeV, Phys. Rev. D64, 072002 (2001).
- Search for Neutral Supersymmetric Higgs Bosons in $p\bar{p}$ Collisions at $\sqrt{s} = 1.8$ TeV, Phys. Rev. Lett. 86, 4472 (2001).
- Measurement of the Top Quark p_T Distribution, Phys. Rev. Lett. 87, 102001 (2001).
- Double Diffraction Dissociation at the Fermilab Tevatron Collider, Phys. Rev. Lett. 87, 141802 (2001).
- Cross Section and Heavy Quark Composition of $\gamma + \mu$ Events Produced in $p\bar{p}$ Collisions, Phys. Rev. D65, 012003 (2001).
- Measurement of $d\sigma/dM$ and Forward-Backward Charge Asymmetry for High-Mass Drell-Yan e^+e^- Pairs from $p\bar{p}$ Collisions at $\sqrt{s} = 1.8$ TeV, Phys. Rev. Lett. 87, 131802 (2001).
- Search for Quark-Lepton Compositeness and a Heavy W' Boson Using the $e\nu$ Channel in $p\bar{p}$ Collisions at $\sqrt{s} = 1.8$ TeV, Phys. Rev. Lett. 87, 231803 (2001).
- Observation of Diffractive J/ψ Production at the Fermilab Tevatron, Phys. Rev. Lett. 87, 241802 (2001).
- Search for Gluinos and Squarks Using Like-Sign Dileptons in $p\bar{p}$ Collisions at $\sqrt{s} = 1.8$ TeV, Phys. Rev. Lett. 87, 251803 (2001).
- Search for Gluinos and Scalar Quarks in $p\bar{p}$ Collisions at $\sqrt{s} = 1.8$ TeV Using the Missing Energy Plus Multijets Signature, Phys. Rev. Lett. 88, 041801 (2002).
- Measurement of the Strong Coupling Constant from Inclusive Jet Production at the Tevatron $p\bar{p}$ Collider, Phys. Rev. Lett. 88, 042001 (2002).
- Search for Narrow Diphoton Resonances and for $\gamma\gamma + W/Z$ Signatures in $p\bar{p}$ Collisions at $\sqrt{s} = 1.8$ TeV, Phys. Rev. D64, 092002 (2001).
- Charged Particle Multiplicity in Jets in $p\bar{p}$ Collisions at $\sqrt{s} = 1.8$ TeV, Phys. Rev. Lett. 87, 211804 (2001).
- Measurement of the B^+ Total Cross Section and B^+ Differential Cross Section $d\sigma/dp_T$ in $p\bar{p}$ Collisions at $\sqrt{s} = 1.8$ TeV, Phys. Rev. D65, 052005 (2002).
- Searches for New Physics in Events with a Photon and b-quark Jet at CDF, Phys. Rev. D65, 052006 (2002).
- Study of the Heavy Flavor Content of Jets Produced in Association with W Bosons in $p\bar{p}$ Collisions at $\sqrt{s} = 1.8$ TeV, Phys. Rev. D65, 052007 (2002).
- Soft and Hard Interactions in $p\bar{p}$ Collisions at $\sqrt{s} = 1800$ and 630 GeV, Phys. Rev. D65, 072005 (2002).
- Search for Single-Top-Quark Production in $p\bar{p}$ Collisions at $\sqrt{s} = 1.8$ TeV, Phys. Rev. D65, 091102 (2002).
- Charged Jet Evolution and the Underlying Event in Proton-Antiproton Collisions at 1.8 TeV, Phys. Rev. D65, 092002 (2002).
- A Study of $B^0 \rightarrow J/\psi K^{(*)0} \pi^+ \pi^-$ Decays with the Collider Detector at Fermilab, Phys. Rev. Lett. 88, 071801 (2002).
- Search for New Heavy Particles in the WZ^0 Final State in $p\bar{p}$ Collisions at $\sqrt{s} = 1.8$ TeV, Phys. Rev. Lett. 88, 071806 (2002).
- Diffractive Dijet Production at $\sqrt{s} = 630$ and 1800 GeV at the Fermilab Tevatron, Phys. Rev. Lett. 88, 151802 (2002).
- Search for the Decay $B_s \rightarrow \mu^+ \mu^- \phi$ in $p\bar{p}$ Collisions at $\sqrt{s} = 1.8$ TeV, Phys. Rev. D65, 111101 (2002).
- Comparison of the Isolated Direct Photon Cross Section in $p\bar{p}$ Collisions at $\sqrt{s} = 1.8$ TeV and $\sqrt{s} = 0.63$ TeV, Phys. Rev. D65, 112003 (2002).

Search for New Physics in Photon-Lepton Events in $p\bar{p}$ Collisions at $\sqrt{s} = 1.8$ TeV, Phys. Rev. D66, 012004 (2002).

Measurement of B Meson Lifetimes Using Fully Reconstructed B Decays Produced in $p\bar{p}$ Collisions at $\sqrt{s} = 1.8$ TeV, Phys. Rev. D65, 092009 (2002).

Υ Production and Polarization in $p\bar{p}$ Collisions at $\sqrt{s} = 1.8$ TeV, Phys. Rev. Lett. 88, 161802 (2002).

Measurement of the Ratio of b Quark Production Cross Sections in $p\bar{p}$ Collisions at $\sqrt{s} = 630$ GeV and $\sqrt{S} = 1.800$ GeV, Phys. Rev. D66, 032002 (2002).

Branching Ratio Measurements of Exclusive B^+ Decays to Charmonium with the Collider Detector at Fermilab, Phys. Rev. D66, 052002 (2002).

Cross Section for Forward J/ψ Production in $p\bar{p}$ Collisions at $\sqrt{s} = 1.8$ TeV, Phys. Rev. D66, 092001 (2002).

Search for Radiative b-Hadron Decays in $p\bar{p}$ Collisions at $\sqrt{s} = 1.8$ TeV, Phys. Rev. D66, 112002 (2002).

Search for New Physics in Photon-Lepton Events in $p\bar{p}$ Collisions at $\sqrt{s} = 1.8$ TeV, Phys. Rev. Lett. 89, 041802 (2002).

Limits on Extra Dimensions and New Particle Production in the Exclusive Photon and Missing Energy Signature in $p\bar{p}$ Collisions at $\sqrt{s} = 1.8$ TeV, Phys. Rev. Lett. 89, 281801 (2002).

Momentum Distribution of Charged Particles in Jets in Dijet Events in $p\bar{p}$ Collisions at $\sqrt{s} = 1.8$ TeV and Comparisons to Perturbative QCD Predictions, Phys. Rev. D68, 012003 (2003).

Search for a W Boson Decaying to a Top and Bottom Quark Pair in 1.8 TeV $p\bar{p}$ Collisions, Phys. Rev. Lett. 90, 081802 (2003).

Search for Long-Lived Charged Massive Particles in $p\bar{p}$ Collisions at $\sqrt{s} = 1.8$ TeV, Phys. Rev. Lett. 90, 131801 (2003).

Search for Associated Production of Upsilon and Vector Boson in $p\bar{p}$ Collisions at $\sqrt{s} = 1.8$ TeV, Phys. Rev. Lett. 90, 221803 (2003).

Search for Supersymmetric Partner of the Top Quark in Dilepton Events from $p\bar{p}$ Collisions at $\sqrt{s} = 1.8$ TeV, Phys. Rev. Lett. 90, 251801 (2003).

Central Pseudorapidity Gaps in Events with a Leading Antiproton at the Fermilab Tevatron $p\bar{p}$ Collider, Phys. Rev. Lett. 91, 011802 (2003).

Measurement of the Mass Difference $m(D_s^+) - m(D^+)$ at CDF II, Phys. Rev. D68, 072004 (2003).

Search for Lepton Flavor Violating Decays of a Heavy Neutral Particle in $p\bar{p}$ Collisions at $\sqrt{s} = 1.8$ TeV, Phys. Rev. Lett. 91, 171602 (2003).

Measurement of Prompt Charm Meson Production Cross Sections in $p\bar{p}$ Collisions at $\sqrt{s} = 1.96$ TeV, Phys. Rev. Lett. 91, 241804 (2003).

Search for the Flavor-Changing Neutral Current Decay $D^0 \rightarrow \mu^+\mu^-$ in $p\bar{p}$ Collisions at $\sqrt{s} = 1.96$ TeV, Phys. Rev. D68, 091101 (2003).

Search for Pair Production of Scalar Top Quarks in R-Parity Violating Decay Modes in $p\bar{p}$ Collisions at $\sqrt{s} = 1.8$ TeV, Phys. Rev. Lett. 92, 051803 (2004).

Measurement of the Average Time-Integrated Mixing Probability of b-Flavored Hadrons Produced at the Tevatron, Phys. Rev. D69, 012002 (2004).

Optimized Search for Single-Top-Quark Production at the Tevatron, Phys. Rev. D69, 052003 (2004).

Heavy Flavor Properties of Jets Produced in $p\bar{p}$ Interactions at $\sqrt{s} = 1.8$ TeV, Phys. Rev. D69, 072004 (2004).

Search for Kaluza-Klein Gravitron Emission in $p\bar{p}$ Collisions at $\sqrt{s} = 1.8$ TeV Using the Missing Energy Signature, Phys. Rev. Lett. 92, 121802 (2004).

- Inclusive Search for Anomalous Production of High- p_T Like-Sign Lepton Pairs in $p\bar{p}$ Collisions at $\sqrt{s} = 1.8$ TeV, Phys. Rev. Lett. 93, 061802 (2004).
- Observation of the Narrow State $X(3872) \rightarrow J/\psi\pi^+\pi^-$ in $p\bar{p}$ Collisions at $\sqrt{s} = 1.96$ TeV, Phys. Rev. Lett. 93, 072001 (2004).
- Inclusive Double Pomeron Exchange at the Fermilab Tevatron $p\bar{p}$ Collider, Phys. Rev. Lett. 93, 141601 (2004).
- Measurement of the $t\bar{t}$ Production Cross Section in $p\bar{p}$ Collisions at 1.96 TeV Using Dilepton Events, Phys. Rev. Lett. 93, 142001 (2004).
- Measurement of the Polar-Angle Distribution of Leptons from W Boson Decay as a Function of the W Transverse Momentum in $p\bar{p}$ Collisions at $\sqrt{s} = 1.8$ TeV, Phys. Rev. D70, 032004 (2004).
- The Underlying Event in Hard Interactions at the Tevatron $p\bar{p}$ Collider, Phys. Rev. D70, 072002 (2004).
- Direct Photon Cross Section with Conversions at CDF, Phys. Rev. D70, 074008 (2004).
- Combination of CDF and D0 Results on W Boson Mass and Width, Phys. Rev. D70, 092008 (2004).
- Search for $B_s^0 \rightarrow \mu^+\mu^-$ and $B_d^0 \rightarrow \mu^+\mu^-$ Decays in $p\bar{p}$ Collisions at 1.96 TeV, Phys. Rev. Lett. 93, 032001 (2004).
- Search for Doubly-Charged Higgs Bosons Decaying to Dileptons in $p\bar{p}$ Collisions at 1.96 TeV, Phys. Rev. Lett. 93, 221802 (2004).
- Search for Electroweak Single Top Quark Production in $p\bar{p}$ Collisions at $\sqrt{s} = 1.96$ TeV, Phys. Rev. D71, 012005 (2005).
- Measurement of the W Boson Polarization in Top Decay at CDF at $\sqrt{s} = 1.8$ TeV, Phys. Rev. D71, 031101 (R) (2005).
- Measurement of the J/ψ Meson and b-Hadron Production Cross Sections in $p\bar{p}$ Collisions at $\sqrt{s} = 1960$ GeV, Phys. Rev. D71, 032001 (2005).
- Comparison of Three-Jet Events in $p\bar{p}$ Collisions at $\sqrt{s} = 1.8$ TeV to Predictions from a Next-to-Leading Order QCD Calculation, Phys. Rev. D71, 032002 (2005).
- Measurement of $W\gamma$ and $Z\gamma$ Production in $p\bar{p}$ Collisions at $\sqrt{s} = 1.96$ TeV, Phys. Rev. Lett. 94, 041803 (2005).
- Search for Anomalous Production of Diphoton Events with Missing Transverse Energy at CDF and Limits on Gauge-Mediated Supersymmetry-Breaking Model, Phys. Rev. D71, 031104 (2005).
- First Measurements of Inclusive W and Z Cross Sections from Run II of the Fermilab Tevatron Collider, Phys. Rev. Lett. 94, 091803 (2005).
- Search for Excited and Exotic Electrons in the $e\gamma$ Decay Channel in $p\bar{p}$ Collisions at $\sqrt{s} = 1.96$ TeV, Phys. Rev. Lett. 94, 101802 (2005).
- Analysis of Decay-Time Dependence of Angular Distributions in $B_s^0 \rightarrow J/\psi\phi$ and $B_d^0 \rightarrow J/\psi K^{*0}$ Decays and Measurement of the Lifetime Difference between B_s Mass Eigenstates, Phys. Rev. Lett. 94, 101803 (2005).
- Measurement of Partial Widths and Search for Direct CP Violation in D^0 Meson Decays to K^-K^+ and $\pi^-\pi^+$, Phys. Rev. Lett. 94, 122001 (2005).
- Measurement of Charged Particle Multiplicities in Gluon and Quark Jets in $p\bar{p}$ Collisions at $\sqrt{s} = 1.8$ TeV, Phys. Rev. Lett. 94, 171802 (2005).
- Measurement of the Moments of the Hadronic Invariant Mass Distribution in Semileptonic B Decays, Phys. Rev. D71, 051103 (2005).
- Measurement of the Forward-Backward Charge Asymmetry from $W \rightarrow e\nu$ Production in $p\bar{p}$ Collisions at $\sqrt{s} = 1.96$ TeV, Phys. Rev. D71, 051104 (2005).

Measurement of the Forward-Backward Charge Asymmetry of Electron-Positron Pairs in $\bar{p}p$ Collisions at $\sqrt{s} = 1.96$ TeV, Phys. Rev. D71, 052002 (2005).

Measurement of the $t\bar{t}$ Production Cross Section in $\bar{p}p$ Collisions at $\sqrt{s} = 1.96$ TeV using Lepton + Jet Events with Secondary Vertex b-Tagging, Phys. Rev. D71, 052003 (2005).

Search for ZZ and ZW Production in $\bar{p}p$ Collisions at $\sqrt{s} = 1.96$ TeV, Phys. Rev. D71, 091105 (2005).

Measurements of Bottom Anti-Bottom Azimuthal Production Correlations in Proton-Antiproton Collisions at $\sqrt{s} = 1.8$ TeV, Phys. Rev. D71, 092001 (2005).

Search for Scalar Leptoquark Pairs Decaying to $\bar{\nu} q\bar{q}$ in $\bar{p}p$ Collisions at $\sqrt{s} = 1.96$ TeV, Phys. Rev. D71, 112001 (2005).

Measurement of the W^+W^- Production Cross Section in $\bar{p}p$ Collisions at $\sqrt{s} = 1.96$ TeV Using Dilepton Events, Phys. Rev. Lett. 94, 211801 (2005).

Search for Anomalous Kinematics in $t\bar{t}$ Dilepton Events at CDF II, Phys. Rev. Lett. 95, 022001 (2005).

Measurement of the Cross Section for Prompt Diphoton Production in $\bar{p}p$ Collisions at $\sqrt{s} = 1.96$ TeV, Phys. Rev. Lett. 95, 022003 (2005).

Evidence for $B_s^0 \rightarrow \phi\phi$ Decay and Measurements of Branching Ratio and A_{CP} for $B^+ \rightarrow \phi K^+$, Phys. Rev. Lett. 95, 031801 (2005).

Search for Higgs Bosons Decaying into $b\bar{b}$ and Produced in Association with a Vector Boson in $\bar{p}p$ Collisions at $\sqrt{s} = 1.8$ TeV, Phys. Rev. Lett. 95, 051801 (2005).

Search for Long-Lived Doubly-Charged Higgs Bosons in $\bar{p}p$ Collisions at $\sqrt{s} = 1.96$ TeV, Phys. Rev. Lett. 95, 071801 (2005).

Measurement of $B(t \rightarrow Wb)/B(t \rightarrow Wq)$ at the Collider Detector at Fermilab, Phys. Rev. Lett. 95, 102002 (2005).

Measurement of the $t\bar{t}$ Production Cross Section in $\bar{p}p$ Collisions at $\sqrt{s} = 1.96$ TeV Using Lepton Plus Jets Events with Semileptonic B Decays to Muons, Phys. Rev. D72, 032002 (2005).

Measurement of the Cross Section for $t\bar{t}$ Production for $\bar{p}p$ Collisions Using the Kinematics of Lepton + Jets Events, Phys. Rev. D72, 052003 (2005).

Search for New Physics Using High Mass Tau Pairs from 1.96 TeV $\bar{p}p$ Collisions, Phys. Rev. Lett. 95, 131801 (2005).

Search for $B_s^0 \rightarrow \mu^+\mu^-$ and $B_d^0 \rightarrow \mu^+\mu^-$ Decays in $\bar{p}p$ Collisions with CDF II, Phys. Rev. Lett. 95, 221805 (2005).

Search for New High Mass Particles Decaying to Lepton Pairs in $\bar{p}p$ Collisions at $\sqrt{s} = 1.96$ TeV, Phys. Rev. Lett. 95, 252001 (2005).

Search for $\Lambda_b^0 \rightarrow p\pi$ and $\Lambda_b^0 \rightarrow pK$ Decays in $\bar{p}p$ Collisions at $\sqrt{s} = 1.96$ TeV, Phys. Rev. D72, 051104 (2005).

Search for First-Generation Scalar Leptoquarks in $\bar{p}p$ Collisions at $\sqrt{s} = 1.96$ TeV, Phys. Rev. D72, 051107 (2005).

K_s^0 and Λ^0 Production Studies in $\bar{p}p$ Collisions at $\sqrt{s} = 1800$ and 630 GeV, Phys. Rev. D72, 052001 (2005).

A Search for Supersymmetric Higgs Bosons in the Di-Tau Decay Mode in $\bar{p}p$ Collisions at $\sqrt{s} = 1.8$ TeV, Phys. Rev. D72, 072004 (2005).

Search for W and Z Bosons in the Reaction $\bar{p}p \rightarrow 2 \text{ Jets} + \gamma$ at $\sqrt{s} = 1.8$ TeV, Phys. Rev. D73, 012001 (2006).

Search for Neutral Higgs Bosons of the Minimal Supersymmetric Standard Model Decaying to τ Pairs in $\bar{p}p$ Collisions at $\sqrt{s} = 1.96$ TeV, Phys. Rev. Lett. 96, 011802 (2006).

Precision Top Quark Mass Measurement in the Lepton + Jets Topology in $p\bar{p}$ Collisions at $\sqrt{s} = 1.96$ TeV, Phys. Rev. Lett. 96, 022004 (2006).

Search for Charged Higgs Bosons from Top Quark Decays in $p\bar{p}$ Collisions at $\sqrt{s} = 1.96$ TeV, Phys. Rev. Lett. 96, 042003 (2006).

Measurement of Bottom-Quark Hadron Masses in Exclusive J/ψ Decays with the CDF Detector, Phys. Rev. Lett. 96, 202001 (2006).

Measurements of the Inclusive W and Z Cross Sections in $p\bar{p}$ Collisions at $\sqrt{s} = 1.96$ TeV, submitted to Phys. Rev. D, Fermilab-Pub-05-360-E.

Measurement of the Ratios of Branching Fractions $B(B_s^0 \rightarrow D_s^- \pi^+)/B(B^0 \rightarrow D^- \pi^+)$ and $B(B^0 \rightarrow \bar{D}^0 \pi^+)/B(B^0 \rightarrow D^- \pi^+)$, Phys. Rev. Lett. 96, 191801 (2006).

Measurement of the Azimuthal Angle Distributions of Leptons from W Boson Decays as a Function of the W Transverse Momentum in $p\bar{p}$ Collisions at $\sqrt{s} = 1.96$ TeV, Phys. Rev. D73, 052002 (2006).

Direct Search for Dirac Magnetic Monopoles in $p\bar{p}$ Collisions at $\sqrt{s} = 1.96$ TeV, Phys. Rev. Lett. 96, 201801 (2006).

Top Quark Mass Measurement Using the Template Method in the Lepton + Jets Channel at CDF II, Phys. Rev. D73, 032003 (2006).

A Search for $t \rightarrow \tau \nu q$ in $t\bar{t}$ Production, Phys. Lett. B639, 172 (2006).

Measurement of the Helicity of W Bosons in Top-Quark Decays, Phys. Rev. D73, 111103 (2006).

Evidence for the Exclusive Decay $B_c^\pm \rightarrow J/\psi \pi^\pm$ and Measurement of the Mass of the B_c^\pm Meson, Phys. Rev. Lett. 96, 082002 (2006).

Measurement of the Top Quark Mass with the Dynamical Likelihood Method Using Lepton plus Jets Events with b-tags in $p\bar{p}$ Collisions at $\sqrt{s} = 1.96$ TeV, Phys. Rev. D73, 092002 (2006).

Measurement of the Inclusive Jet Cross Section Using the k_T Algorithm in $p\bar{p}$ Collisions at $\sqrt{s} = 1.96$ TeV, Phys. Rev. Lett. 96, 122001 (2006).

Measurement of $\sigma_{\Lambda_b^0}/\sigma_{\bar{B}^0} \times B(\Lambda_b^0 \rightarrow \Lambda_c^+ \pi^-)/B(\bar{B}^0 \rightarrow D^+ \pi^-)$ in $p\bar{p}$ Collisions at $\sqrt{s} = 1.96$ TeV, submitted to Phys. Rev. Lett., Fermilab-Pub-05-574-E.

Measurement of the Dipion Mass Spectrum in $X(3872) \rightarrow J/\psi \pi^+ \pi^-$ Decays, Phys. Rev. Lett. 96, 102002 (2006).

Search for Second-Generation Scalar Leptoquarks in $p\bar{p}$ Collisions at $\sqrt{s} = 1.96$ TeV, Phys. Rev. D73, 051102 (2006).

Search for Higgs Bosons Decaying to $b\bar{b}$ and Produced in Association with W Bosons in $p\bar{p}$ Collisions at $\sqrt{s} = 1.96$ TeV, Phys. Rev. Lett. 96, 081803 (2006).

Top Quark Mass Measurement from Dilepton Events at CDF II, Phys. Rev. Lett. 96, 152002 (2006).

Measurement of the Inclusive Jet Cross Section in $p\bar{p}$ Interactions at $\sqrt{s} = 1.96$ TeV Using a Cone-based Jet Algorithm, Phys. Rev. D74, 071103 (2006).

Search for Anomalous Semileptonic Decay of Heavy Flavor Hadrons Produced in Association with a W Boson at CDF II, Phys. Rev. D73, 051101 (2006).

Measurement of Mass and Width of the Excited Charmed Meson States D_1^0 and D_2^{*0} at CDF, Phys. Rev. D73, 051104 (2006).

A Search for Scalar Bottom Quarks from Gluino Decays in $p\bar{p}$ Collisions at $\sqrt{s} = 1.96$ TeV, Phys. Rev. Lett. 96, 171802 (2006).

Measurement of the Top Quark Mass Using Template Methods on Dilepton Events in $p\bar{p}$ Collisions at $\sqrt{s} = 1.96$ TeV, Phys. Rev. D73, 112006 (2006).

Observation of $B_s^0 \rightarrow \psi(2S)\phi$ and Measurement of Ratio of Branching Fractions $B(B_s^0 \rightarrow \psi(2S)\phi)/B(B_s^0 \rightarrow J/\psi\phi)$, Phys. Rev. Lett. 96, 231801 (2006).

Search for $Z' e^+e^-$ Using Dielectron Mass and Angular Distribution, Phys. Rev. Lett. 96, 211801 (2006).

Search for High-Mass Resonances Decaying to $e\mu$ in $p\bar{p}$ Collisions at $\sqrt{s} = 1.96$ TeV, Phys. Rev. Lett. 96, 211802 (2006).

Measurement of the B_c^+ Meson Lifetime Using $B_c^+ \rightarrow J/\psi e^+ \nu_e$, Phys. Rev. Lett. 97, 012002 (2006).

Measurement of the $t\bar{t}$ Production Cross Section in $p\bar{p}$ Collisions at $\sqrt{s} = 1.96$ TeV Using Missing E_T + Jets Events with Secondary Vertex b-Tagging, Phys. Rev. Lett. 96, 202002 (2006).

Search for Large Extra Dimensions in the Production of Jets and Missing Transverse Energy in $p\bar{p}$ Collisions at $\sqrt{s} = 1.96$ TeV, Phys. Rev. Lett. 97, 171802 (2006).

Measurement of the Ratio of Branching Fractions $B(D^0 \rightarrow K^+\pi^-)/D^0 \rightarrow K^-\pi^+$ using the CDF II Detector, Phys. Rev. D74, 031109 (2006).

Search for New Physics in Lepton + Photon + X Events with 305 pb^{-1} of $p\bar{p}$ Collisions at $\sqrt{s} = 1.96$ TeV, Phys. Rev. Lett. 97, 031801 (2006).

Measurement of the b Jet Cross Section in Events with a Z Boson in $p\bar{p}$ Collisions at $\sqrt{s} = 1.96$ TeV, Phys. Rev. D74, 032008 (2006).

Search for a Neutral Higgs Boson Decaying to a W Boson Pair in $p\bar{p}$ Collisions at $\sqrt{s} = 1.96$ TeV, Phys. Rev. Lett. 97, 081802 (2006).

Top Quark Mass Measurement from Dilepton Events at CDF II with the Matrix-Element Method, Phys. Rev. D74, 032009 (2006).

Measurement of the $t\bar{t}$ Production Cross Section in $p\bar{p}$ Collisions at $\sqrt{s} = 1.96$ TeV, Phys. Rev. Lett. 97, 082004 (2006).

Measurement of the $B_s^0 - \bar{B}_s^0$ Oscillation Frequency, Phys. Rev. Lett. 97, 062003 (2006).

Search for Excited and Exotic Muons in the $\mu\gamma$ Decay Channel in $p\bar{p}$ Collisions at $\sqrt{s} = 1.96$ TeV, Phys. Rev. Lett. 97, 191802 (2006).

Measurement of $B_s^0 \rightarrow K^+K^-$ and Measurements of Branching Fractions of Charmless Two-body Decays of B^0 and B_s^0 Mesons in $p\bar{p}$ Collisions at $\sqrt{s} = 1.96$ TeV, Phys. Rev. Lett. 97, 211802 (2006).

Measurement of the $t\bar{t}$ Production Cross Section in $p\bar{p}$ Collisions at $\sqrt{s} = 1.96$ TeV Using Lepton + Jets Events with Jet Probability b-Tagging, Phys. Rev. D74, 072006 (2006).

Measurement of the $t\bar{t}$ Production Cross Section in $p\bar{p}$ Collisions at $\sqrt{s} = 1.96$ TeV in the All Hadronic Decay Mode, Phys. Rev. D74, 072005 (2006).

Search for V + A Current in Top Quark Decay in $p\bar{p}$ Collisions at $\sqrt{s} = 1.96$ TeV, Phys. Rev. Lett. 98, 072001 (2007).

Measurement of the Λ_b^0 Lifetime in $\Lambda_b^0 \rightarrow J/\psi \Lambda^0$ in $p\bar{p}$ Collisions at $\sqrt{s} = 1.96$ TeV, submitted to Phys. Rev. Lett., Fermilab-Pub-06-321-E.

Observation of $B_s^0 - \bar{B}_s^0$ Oscillations, Phys. Rev. Lett. 97, 242003 (2006).

Measurement of the Ratios of Branching Fractions $B(B_s^0 \rightarrow D_s^- \pi^+ \pi^+ \pi^-)/B(B^0 \rightarrow D^- \pi^+ \pi^+ \pi^-)$ and $B(B_s^0 \rightarrow D_s^- \pi^+)/B(B^0 \rightarrow D^- \pi^+)$, Phys. Rev. Lett. 98, 061802 (2007).

Search for Exotic $S = -2$ Baryons in $p\bar{p}$ Collisions at $\sqrt{s} = 1.96$ TeV, Phys. Rev. D75, 032003 (2007).

Search for W' Boson Decaying to Electron-Neutrino Pairs in $p\bar{p}$ Collisions at $\sqrt{s} = 1.96$ TeV, submitted to Phys. Rev. D, Fermilab-Pub-06-419-E.

Observation of Exclusive Electron-Positron Production in Hadron-Hadron Collisions, submitted to Phys. Rev. Lett., Fermilab-Pub-06-436-E.

Measurement of the Helicity Fractions of W Bosons from Top Quark Decays using Full Reconstructed $t\bar{t}$ Events with CDF II, submitted to Phys. Rev. Lett., Fermilab-Pub-06-461-E.

Measurement of the B^+ Production Cross Section in $p\bar{p}$ Collisions at $\sqrt{s} = 1960$ GeV, submitted to Phys. Rev. D, Fermilab-Pub-06-458-E.

Measurement of the Top-Quark Mass in All-Hadronic Decays in $p\bar{p}$ Collisions at CDF II, submitted to Phys. Rev. Lett., Fermilab-Pub-06-468-E.

Search for Anomalous Production of Multi-lepton Events in $p\bar{p}$ Collisions at $\sqrt{s} = 1.96$ TeV, submitted to Phys. Rev. Lett., Fermilab-Pub-06-482-E.

Analysis of Quantum Numbers J^{PC} of the X(3872), submitted to Phys. Rev. Lett., Fermilab-Pub-06-485-E.

Cross Section Measurements of High- p_T Dilepton Final-State Processes Using a Global Fitting Method, submitted to Phys. Rev. D Rapid Communications, Fermilab-Pub-06-486-E.

Measurement of the Top Quark Mass in $p\bar{p}$ Collisions at $\sqrt{s} = 1.96$ TeV using the Decay Length Technique, submitted to Phys. Rev. D Rapid Communications, Fermilab-Pub-06-487-E.

Precision Measurement of the Top Quark Mass from Dilepton Events at CDF II, submitted to Phys. Rev. Lett., Fermilab-Pub-06-490-E.

Measurement of the Inclusive Jet Cross Section Using the k_T Algorithm in $p\bar{p}$ Collisions at $\sqrt{s} = 1.96$ TeV with the CDF II Detector, submitted to Phys. Rev. D, Fermilab-Pub-07-026-E.

Theses

G. Chiarelli	University of Pisa	March 1985
M. Sekiguchi	University of Tsukuba	
S. E. Kuhlmann	Purdue University	August 1988
D. A. Smith	University of Illinois	December 1988
T. K. Westhusing	University of Illinois	December 1988
R. D. St. Denis	Harvard University	December 1988
M. Miller	University of Pennsylvania	December 1988
Y. Morita	University of Tsukuba	January 1989
D. N. Brown	Harvard University	June 1989
R. M. Carey	Harvard University	July 1989
M. H. Schub	Purdue University	August 1989
R. M. Harris	Lawrence Berkeley Laboratory	August 1989
B. L. Flaughner	Rutgers University	October 1989
J. E. Skarha	University of Wisconsin	1989
B. Hubbard	Lawrence Berkeley Laboratory	November 1989
A. Byon	Purdue University	December 1989
G. Redlinger	University of Chicago	1989
Y. Tsay	University of Chicago	1989
W. Trischuk	Harvard University	April 1990
F. Snider	University of Chicago	March 1990
M. Contreras	Brandeis University	April 1990
H. Keutelian	University of Illinois	May 1990
S. Leone	University of Pisa	June 1990
P. Hu	Rutgers University	June 1990
S. Kanda	University of Tsukuba	June 1990
P. Schlabach	University of Illinois	August 1990
J. Walsh	University of Pennsylvania	1990
T. Mimashi	University of Tsukuba	September 1990
P. Hurst	University of Illinois	October 1990
P. Derwent	University of Chicago	November 1990
T. Hessing	Texas A&M University	December 1990
B. L. Winer	Lawrence Berkeley Laboratory	February 1991
G. Punzi	Scuola Normale Superiore Pisa	February 1991
J. Ng	Harvard University	May 1991
A. Roodman	University of Chicago	June 1991
L. DeMortier	Brandeis University	September 1991

F. Ukegawa	University of Tsukuba	September 1991
L. Song	University of Pennsylvania	October 1991
D. Connor	University of Pennsylvania	November 1991
K. Byrum	University of Wisconsin	December 1991
V. Scarpine	University of Illinois	December 1991
R. Hughes	University of Pennsylvania	January 1992
L. Markosky	University of Wisconsin	January 1992
M. Ninomiya	University of Tsukuba	January 1992
Y. Seiya	University of Tsukuba	January 1992
S. Ogawa	University of Tsukuba	January 1992
L. Nakae	Brandeis University	April 1992
R. Markeloff	University of Wisconsin	August 1992
D. Gerdes	University of Chicago	September 1992
L. Keeble	Texas A&M University	September 1992
B. T. Huffman	Purdue University	December 1992
S. Vejck	Johns Hopkins University	August 1992
S. M. Moulding	Brandeis University	February 1993
P. A. Maas	University of Wisconsin	August 1993
M. Incagli	University of Pisa	October 1993
V. Bolognesi	University of Pisa	October 1993
R. Drucker	Univ. of California/Berkeley	November 1993
D. Benjamin	Tufts University	November 1993
J. Lamoureux	University of Wisconsin	December 1993
C. Boswell	Johns Hopkins University	December 1993
R. Schwartz	University of Illinois	December 1993
C. Luchini	University of Illinois	December 1993
C. Jessop	Harvard University	December 1993
M. Roach-Bellino	Tufts University	January 1994
D. Kardelis	University of Illinois	January 1994
S. Dell'Agnello	University of Pisa	February 1994
S. Leone	University of Pisa	February 1994
M. Cobal	University of Pisa	February 1994
B. Farhat	Mass. Institute of Technology	February 1994
R. Mattingly	Brandeis University	March 1994
T. Chikamatsu	University of Tsukuba	April 1994
W. Wester	Univ. of California/Berkeley	April 1994
M. W. Bailey	Purdue University	May 1994
S. Kopp	University of Chicago	May 1994
M. Dickson	University of Rochester	May 1994
M. Takano	University of Tsukuba	June 1994
A. Spies	John Hopkins University	July 1994
J. Tonnison	Purdue University	August 1994
Y. Cen	University of Pennsylvania	August 1994
B. Badgett	University of Michigan	September 1994
D. Saltzberg	University of Chicago	October 1994
N. Turini	University of Bologna	November 1994
T. Song	University of Michigan	December 1994
J. Wang	University of Chicago	December 1994
G. Watts	University of Rochester	December 1994
M. Vondracek	University of Illinois	December 1994
R. Oishi	University of Tsukuba	January 1995
D. Lucchesi	University of Pisa	February 1995
R. Keup	University of Illinois	February 1995
C. Anway-Wiese	Univ. of California/Los Angeles	June 1995
J. Romano	University of Chicago	August 1995
C. Hawk	Rutgers University	October 1995
E. Meschi	Scuola Normale Superiore, Pisa	October 1995
D. Glenzinski	Johns Hopkins University	November 1995
S. Hauger	Duke University	December 1995

D. Neuberger	Univ. of California/Los Angeles	December 1995
S. Rolli	Pavia University	January 1996
H. Mitsushio	University of Tsukuba	January 1996
R. Hans	Yale University	January 1996
G. Tartarelli	University of Milan	January 1996
P. Azzi	University of Padova	February 1996
M. Gallinaro	University of Rome	February 1996
M. Kruse	Purdue University	February 1996
I. Yu	Yale University	February 1996
T. Asakawa	University of Tsukuba	February 1996
F. Azfar	University of Pennsylvania	March 1996
A. Martin	University of Illinois	April 1996
G. Houk	University of Pennsylvania	April 1996
J. Tseng	Johns Hopkins University	May 1996
A. Maghakian	Rockefeller University	May 1996
D. Kestenbaum	Harvard University	May 1996
T. Baumann	Harvard University	May 1996
P. Yeh	National Taiwan University	June 1996
Y. Kato	Osaka University	June 1996
T. Ino	University of Tsukuba	June 1996
G. Sganos	University of Toronto	June 1996
J. Cammerata	John Hopkins University	August 1996
L. Zhang	University of Wisconsin	August 1996
E. Hayashi	University of Tsukuba	September 1996
M. Pillai	University of Rochester	September 1996
F. Keyvan	Univ. of California/Los Angeles	September 1996
S. Metzler	University of Pennsylvania	December 1996
P. Koehn	University of Rochester	December 1996
F. Qun	University of Rochester	December 1996
S. Aota	University of Tsukuba	January 1997
M. Shimojima	University of Tsukuba	January 1997
T. Daniels	Massachusetts Institute of Technology	April 1997
W. Bokhari	Massachusetts Institute of Technology	April 1997
C. C. Miao	University of Michigan	May 1997
M. Peters	University of California/Berkeley	May 1997
C. Couyoumtzelis	University of Geneva	June 1997
A. Titov	Rockefeller University	June 1997
T. Kuwabara	University of Tsukuba	June 1997
H. Sato	University of Tsukuba	June 1997
M. Hohlmann	University of Chicago	August 1997
D. Cronin-Hennessy	Duke University	August 1997
T. Takano	University of Tsukuba	September 1997
K. Tollefson	University of Rochester	October 1997
S. Bagdasarov	Rockefeller University	October 1997
O. Long	University of Pennsylvania	November 1997
P. Maksimovic	Massachusetts Institute of Technology	November 1997
K. Burkett	University of Michigan	December 1997
H. Kambara	University of Geneva	December 1997
B. Tannenbaum	University of New Mexico	December 1997
D. Toback	University of Chicago	December 1997
E. Kuns	Rutgers University	December 1997
A. Warburton	University of Toronto	December 1997
E. Cocca	University of Pisa	January 1998
J. Suzuki	University of Tsukuba	January 1998
M. Okabe	University of Tsukuba	January 1998
S. Vandenbrink	University of Pittsburgh	January 1998
N. Buseti	University of Padova	February 1998
W. Ashmanskas	University of California/Berkeley	May 1998
L. Scodellaro	University of Padova	July 1998

M. Scardellato	University of Padova	July 1998
R. Rossin	University of Padova	July 1998
A. Bocci	University of Pisa	July 1998
K. Hoffman	Purdue University	July 1998
J. Olsen	University of Wisconsin	August 1998
L. Groer	Rutgers University	October 1998
A. Gordon	Harvard University	November 1998
J. Dittmann	Duke University	December 1998
H. Ikeda	University of Tsukuba	January 1999
H. Minato	University of Tsukuba	January 1999
B. Hinrichsen	University of Toronto	January 1999
T. Handa	Hiroshima University	January 1999
H. Kim	University of Toronto	January 1999
W. Taylor	University of Toronto	January 1999
D. Vucinic	Massachusetts Institute of Technology	February 1999
K. Kelley	Massachusetts Institute of Technology	February 1999
N. Eddy	University of Michigan	February 1999
N. Moggi	University of Pavia	April 1999
K. Karr	Tufts University	May 1999
E. Guillian	University of Michigan	May 1999
A. Akopian	Rockefeller University	June 1999
P. Chang	National Tsing Hua University	June 1999
N. Bruner	University of New Mexico	July 1999
A. Hardman	Purdue University	August 1999
J. Wahl	University of Chicago	August 1999
J. Done	Texas A&M University	August 1999
A. Koengeter	University of Karlsruhe	November 1999
T. Kikuchi	University of Tsukuba	December 1999
K. Kordas	McGill University	December 1999
S. Pappas	Yale University	December 1999
K. Terashi	University of Tsukuba	January 2000
J. Guimaraes da Costa	University of Michigan	January 2000
J. Cassada	University of Rochester	January 2000
A. Scott	Univ. of California/Los Angeles	February 2000
T. Keaffaber	Purdue University	May 2000
J. Steele	University of Wisconsin	May 2000
D. Winn	University of Michigan	May 2000
C. Mesropian	Rockefeller University	June 2000
J. Liu	University of Rochester	June 2000
T. Shah	Massachusetts Institute of Technology	July 2000
R. Cropp	University of Toronto	August 2000
M. Spiropulu	Harvard University	August 2000
T. Speer	University of Geneva	September 2000
A. Robinson	University of Toronto	September 2000
J. Berryhill	University of Chicago	December 2000
P. Gatti	University of Padova	December 2000
M. P. Giordani	University of Padova	December 2000
M. Tanaka	University of Tsukuba	January 2001
C.-Y. P. Ngan	University of Rochester	February 2001
G. Latino	University of Cassino	February 2001
H. Nakada	University of Tsukuba	March 2001
A. Safonov	University of Florida	April 2001
S. Bailey	Harvard University	April 2001
M. J. Kim	Kyungpook National University	April 2001
L. Christofek	University of Illinois	May 2001
D. Partos	Brandeis University	May 2001
R. Haas	University of Florida	May 2001
A. Solodsky	Rockefeller University	May 2001
C. Hill	University of California/Davis	September 2001

A. Cerri	Scuola Normale Superiore of Pisa	October 2001
T. Gao	University of Pennsylvania	October 2001
F. Strumia	University of Geneva	December 2001
C. Smith	Johns Hopkins University	January 2002
L. Scodellaro	Padova University	February 2002
A. Taffard	University of Liverpool	March 2002
S. Murgia	Michigan State University	May 2002
J. Carlson	University of Michigan	May 2002
M. Martin	University of Oxford	May 2002
S. Wolinski	University of Michigan	May 2002
C. Hall	Harvard University	May 2002
A. Heiss	Karlsruhe University	June 2002
L. Cerrito	University College London	June 2002
M. Brozovic	Duke University	August 2002
C. Ciobanu	Ohio State University	August 2002
Y. Miyazaki	Osaka City University	September 2002
C. Sanchez	Ohio State University	
A. Affolder	University of California/Berkeley	December 2002
A. Brandl	University of New Mexico	December 2002
O. Lobban	Texas Tech. University	December 2002
A. Pompos	Purdue University	December 2002
T. Pratt	Oxford University	January 2003
R. Rossin	Universita di Roma "La Sapienza"	January 2003
P. Schemitz	Karlsruhe University	January 2003
S. Menzemer	Karlsruhe University	January 2003
M. Kirk	Brandeis University	February 2003
H. Niu	Brandeis University	February 2003
H. Takano	University of Tsukuba	April 2003
C. Chen	University of Pennsylvania	May 2003
A. Gresele	University of Bologna	May 2003
M. Krasberg	University of Michigan	May 2003
K. Hatakeyama	Rockefeller University	June 2003
H. Stadie	Karlsruhe University	July 2003
C. Neu	Ohio State University	July 2003
J. Lancaster	Duke University	August 2003
K. Lannon	University of Illinois	September 2003
R. Madrak	Harvard University	September 2003
G. Manca	Oxford University	December 2003
A. Connolly	University of California/Berkeley	December 2003
J. Chung	Ohio State University	December 2003
G. Veramendi	University of California/Berkeley	December 2003
T. Pauly	Oxford University	December 2003
Y. Le	Johns Hopkins University	December 2003
K. Yi	Johns Hopkins University	December 2003
S. Tsuno	University of Tsukuba	January 2004
H. Ray	University of Michigan	March 2004
K. Ikado	Waseda University	March 2004
D. Goldstein	Univ. of California/Los Angeles	March 2004
I. Furic	Massachusetts Institute of Technology	March 2004
D. Tsybychev	University of Florida	March 2004
B. Kilminster	University of Rochester	April 2004
A. Varganov	University of Michigan	April 2004
S. Waschke	University of Glasgow	April 2004
A. Korn	Massachusetts Institute of Technology	May 2004
M. Worcester	Univ. of California/Los Angeles	June 2004
H. Gerberich	Duke University	July 2004
S. Farrington	University of Glasgow	August 2004
D. Ryan	Tufts University	August 2004
K. Anikeev	Massachusetts Institute of Technology	September 2004

M. Coca	University of Rochester	September 2004
M. Mulhearn	Massachusetts Institute of Technology	September 2004
M. Kirby	Duke University	October 2004
R. Napora	Johns Hopkins University	October 2004
Y. Liu	University of Geneva	November 2004
M. Karagoz Unel	Northwestern University	December 2004
G. Flanagan	Michigan State University	December 2004
A. Ivanov	University of Rochester	December 2004
C. Rott	Purdue University	December 2004
H. Bachacou	Univ. of California/Berkeley	December 2004
T. Vickey	Univ. of Illinois/Urbana-Champaign	December 2004
M. J. Turner	University of Liverpool	December 2004
M. S. Kim	Kyungpook National University	December 2004
R. Marginean	University of Ohio	December 2004
J. Kang	University of Michigan	December 2004
D. Ryan	Tufts University	January 2005
K. Ikado	Waseda University	February 2005
A. Robson	Oxford University	February 2005
C. Rott	Purdue University	March 2005
H. Gerberich	Duke University	March 2005
M. Kim	Kyungpook National University	March 2005
Z. Wan	Rutgers University	April 2005
S-S. Yu	University of Pennsylvania	April 2005
N. Tanimoto	Okayama University	April 2005
T. Unverhau	Glasgow University	April 2005
T. Vickey	University of Illinois	April 2005
A. Bocci	Rockefeller University	April 2005
S. Demers Konezny	University of Rochester	May 2005
E. Brubaker	University of California/Berkeley	May 2005
K. Sato	University of Tsukuba	May 2005
A. Ivanov	University of Rochester	May 2005
A. Pranko	University of Florida	May 2005
D. Tsybychev	University of Florida	May 2005
T. Ogawa	Waseda University	May 2005
K. Yorita	Waseda University	May 2005
M. Henneke	Karlsruhe University	June 2005
T. Walter	Karlsruhe University	June 2005
A. Rakitin	Massachusetts Institute of Technology	July 2005
A. Cruz	University of Florida	July 2005
C. Lecci	Karlsruhe University	July 2005
J. Piedra	Universidad de Cantabria	August 2005
S. Rappoccio	Harvard University	August 2005
A. Giurgiu	Carnegie Mellon University	September 2005
N. Pozzobon	University of Pisa	September 2005
G. Veramendi	University of Tsukuba	September 2005
Y. Ishizawa	University of Tsukuba	September 2005
L. Nicolas	University of Glasgow	September 2005
J. Tuttle	Duke University	October 2005
O. Stelzer-Chilton	University of Toronto	October 2005
N. Goldschmidt	University of Michigan	November 2005
U. Kerzel	Karlsruhe University	November 2005
J.-F. Arguin	University of Toronto	December 2005
A. Gajjar	University of Liverpool	December 2005
R. Eusebi	University of Rochester	December 2005
D. McGivern	University College London	December 2005
H. Hayward	University of Liverpool	December 2005
C. Liu	Yale University	December 2005
D. Hirschbuehl	Karlsruhe University	December 2005
B. Stelzer	University of Toronto	January 2006

S. Uozumi	University of Tsukuba	January 2006
S. Amerio	University of Padova	January 2006
A. Kovalev	University of Pennsylvania	January 2006
V. Krutelyov	Texas A&M University	January 2006
D. Usynin	University of Pennsylvania	January 2006
T. Yamashita	Okayama University	January 2006
S. Da Ronco	Padova University	March 2006
G. Cortiana	Padova University	March 2006
M. Aoki	University of Tsukuba	April 2006
R. Vilar	University of Cantabria	April 2006
R. Tsuchiya	Waseda University	May 2006
J. Kim	Kyungpook National University	June 2006
A. Lister	University of Geneva	June 2006
K. Gibson	Carnegie Mellon University	June 2006
A. Hamilton	University of Alberta	June 2006
K. Hahn	University of Pennsylvania	July 2006
B. Jayatilaka	University of Michigan	August 2006
N. Leonardo	Massachusetts Institute of Technology	September 2006
C. Group	University of Florida	November 2006
A. Attal	Univ. of California, Los Angeles	November 2006
P. Squillacioti	Siena University	December 2006
S.-H. Chuang	University of Wisconsin	December 2006
S. Baroiant	University of California, Davis	December 2006
A. Gibson	University of California, Berkeley	December 2006
D. Tonelli	Scuola Normale Superiore of Pisa	January 2007
A. Buzatu	McGill University	January 2007
S. Sabik	University of Toronto	February 2007

E831 Spectrometer Layout

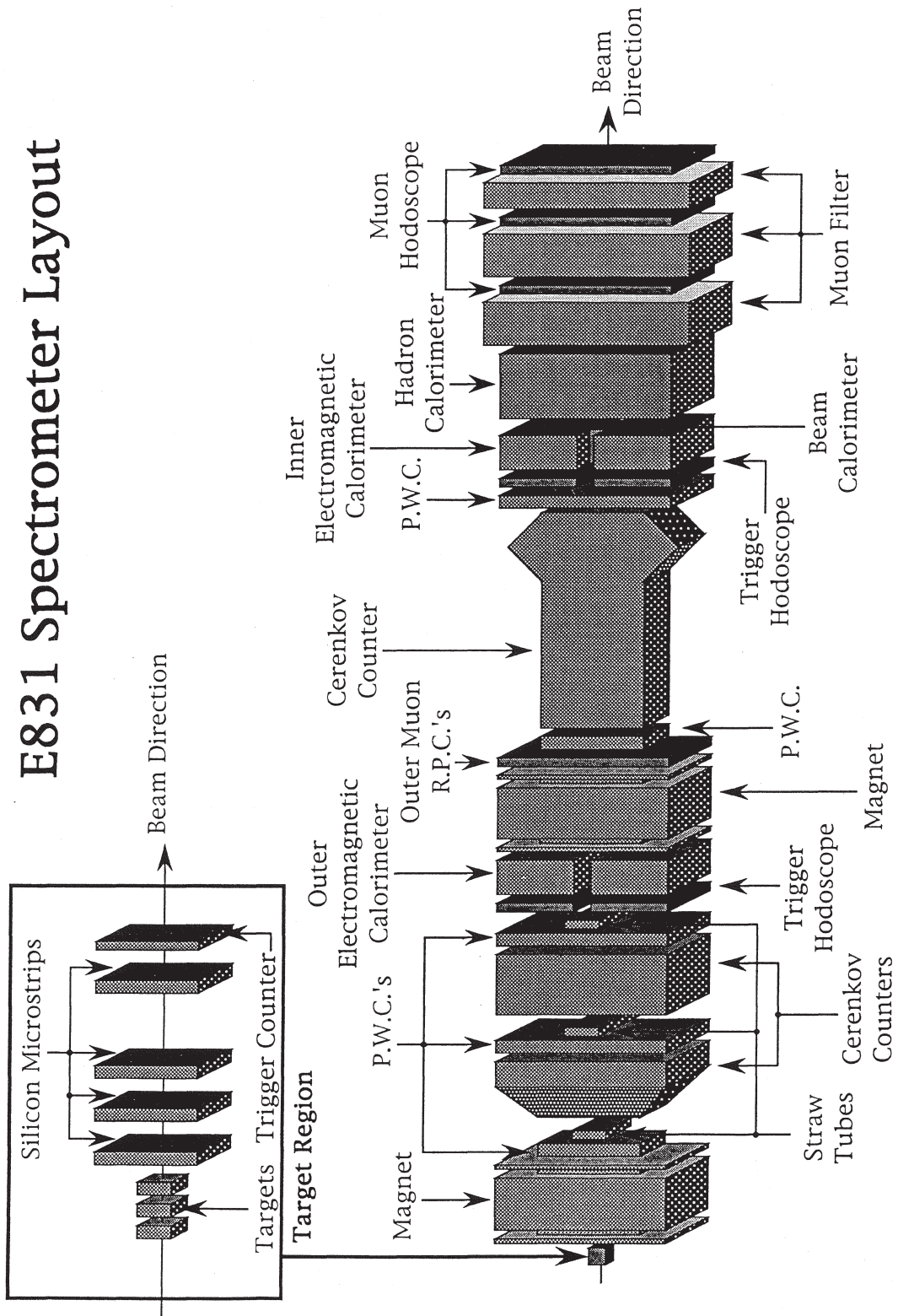

**E-831 (Cumalat / Moroni) A High Statistics Study of States
Containing Heavy Quarks Using the Wideband Photon Beam and
the E-687 Multiparticle Spectrometer**

*UC/Davis, CBPF (Brazil), CINVESTAV (Mexico), Colorado,
Fermilab, INFN/Frascati (Italy), Illinois/Champaign, Korea (Korea),
INFN/Milano (Italy), Milano (Italy), North Carolina, INFN/Pavia (Italy),
Pavia (Italy), Puebla (Mexico), Puerto Rico/Mayaguez, South Carolina,
Tennessee, Vanderbilt, Wisconsin, Yeonsei (Korea)*

Status: *Data Analysis*

E-831 (FOCUS) is a high-intensity photoproduction experiment that is designed to study the production and decay of charmed particles. The experiment enjoyed a successful data-taking period during 1996 and 1997. The spectrometer has excellent particle identification with three Cerenkov counters, two electromagnetic calorimeters, and several scintillator arrays for muon detection. A scintillating fiber calorimeter is used to identify neutrons and to determine the energy of the hadronic event. The vertex region contains segmented BeO targets interleaved with silicon strip detectors. The vertex region is followed by 12 planes of silicon strip detectors.

The physics of the experiment involves high-precision studies of D semileptonic decays with an emphasis on the determination of form factors and CKM matrix elements $|V_{cd}|$ and $|V_{cs}|$, QCD studies of Double D events, a measurement of the absolute branching fraction for the D^0 meson, searches for D^0 mixing using hadronic and semileptonic final states, and searches for CP violation, rare and forbidden decays, fully leptonic decays of the D^+ , and a systematic investigation of charm baryons and their lifetimes.

In 2006 we published four papers. They include the first non-parametric measurement of D^+ semileptonic form factors. In this paper we present the first non-parametric analysis of the helicity basis form factors which control the decay $D^+ \rightarrow K^- \pi^+ \mu^+ \nu$. This method should prove valuable to e^+e^- charm factories that have better q^2 resolution. In the second paper we study CP violation and the decay asymmetry parameters in $\Lambda_c^+ \rightarrow \Lambda \pi^+$ decays. In the third paper we make a new branching fraction measurement of $D^+ \rightarrow \rho^0 \mu^+ \nu$ relative to $D^+ \rightarrow \bar{K}^{*0} \mu^+ \nu$. In this paper we make a measurement which is consistent with the CLEO collaboration made using semielectronic decays. The semi-muonic measurement represents a significant improvement to the world average on this decay. Lastly, we conduct a search for a pentaquark decaying to pK_s . Finding no evidence for such a state we set limits on the yield and the cross section times branching fraction relative to $\Sigma^*(1385)$ and $K^*(892)^+$.

In addition to these papers we have submitted two additional papers for publication, namely a non-parametric approach (complementary to a Dalitz plot analysis) to measuring the $K^- \pi^+$ amplitudes in the decay $D^+ \rightarrow K^+ K^- \pi^+$ and a study of the four body decay $D^0 \rightarrow \pi^- \pi^+ \pi^- \pi^+$.

The technique used in the non-parametric amplitude analysis of $K^-\pi^+$ amplitudes in the decay $D^+ \rightarrow K^+K\pi^+$ does not require assumptions about Breit-Wigner resonances, forms for mass dependent widths, hadronic form factors, or Zemach momentum factors. Not much is known about including broad S-wave resonances in charm Dalitz analyses and the paper finds considerable discrepancies between the non-parametric description of the S-wave $K^-\pi^+$ amplitude and the PDG $K^{*0}(1430)$ parametrization.

In the $D^0 \rightarrow \pi^-\pi^+\pi^-\pi^+$ paper (see Figures 1 and 2), we measure the branching ratio of $\Gamma(D^0 \rightarrow \pi^-\pi^+\pi^-\pi^+)/\Gamma(D^0 \rightarrow K^-\pi^+\pi^-\pi^+) = 0.0914 \pm 0.0018 \pm 0.0022$. A four body amplitude analysis is performed to determine the resonant substructure. The dominant component of the decay is $D^0 \rightarrow a_1(1260)^+\pi^-$, accounting for 60% of the decay rate. The second largest contribution comes from $D^0 \rightarrow \rho(770)^0\rho(770)^0$ with a fraction of 25%. We also study the $a_1(1260)$ line shape and resonant substructure and using helicity formalism for the angular distribution of $D^0 \rightarrow \rho(770)^0\rho(770)^0$, we find a longitudinal polarization of $P_L = (71 \pm 4 \pm 2)\%$.

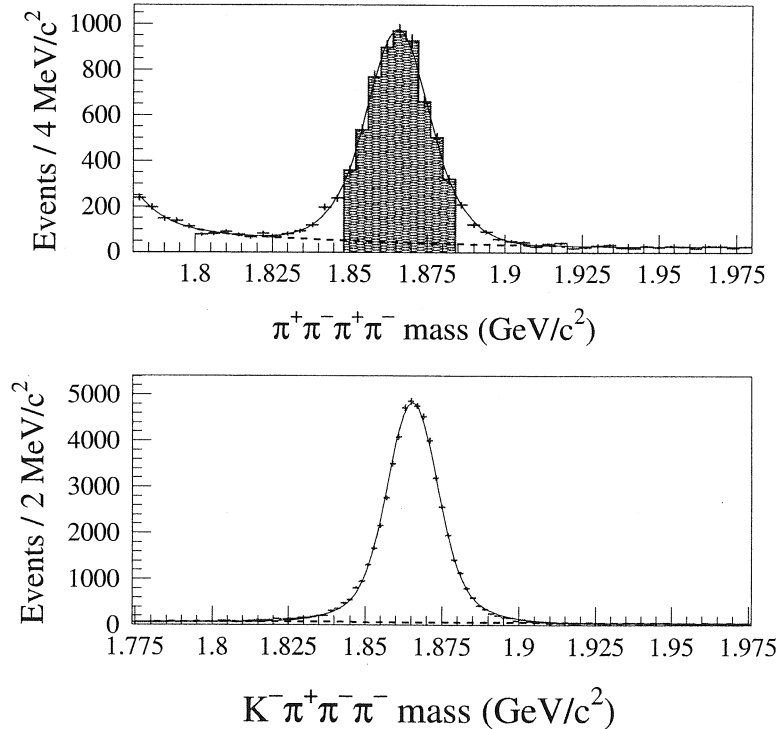

Figure 1. Invariant mass distributions used to determine the ratio of branching fractions. The upper plot is the $\pi^-\pi^+\pi^-\pi^+$ signal: the lower plot is the normalizing channel $K^-\pi^+\pi^-\pi^+$. The hatched area on the $\pi^-\pi^+\pi^-\pi^+$ signal corresponds to the events used in the amplitude analysis.

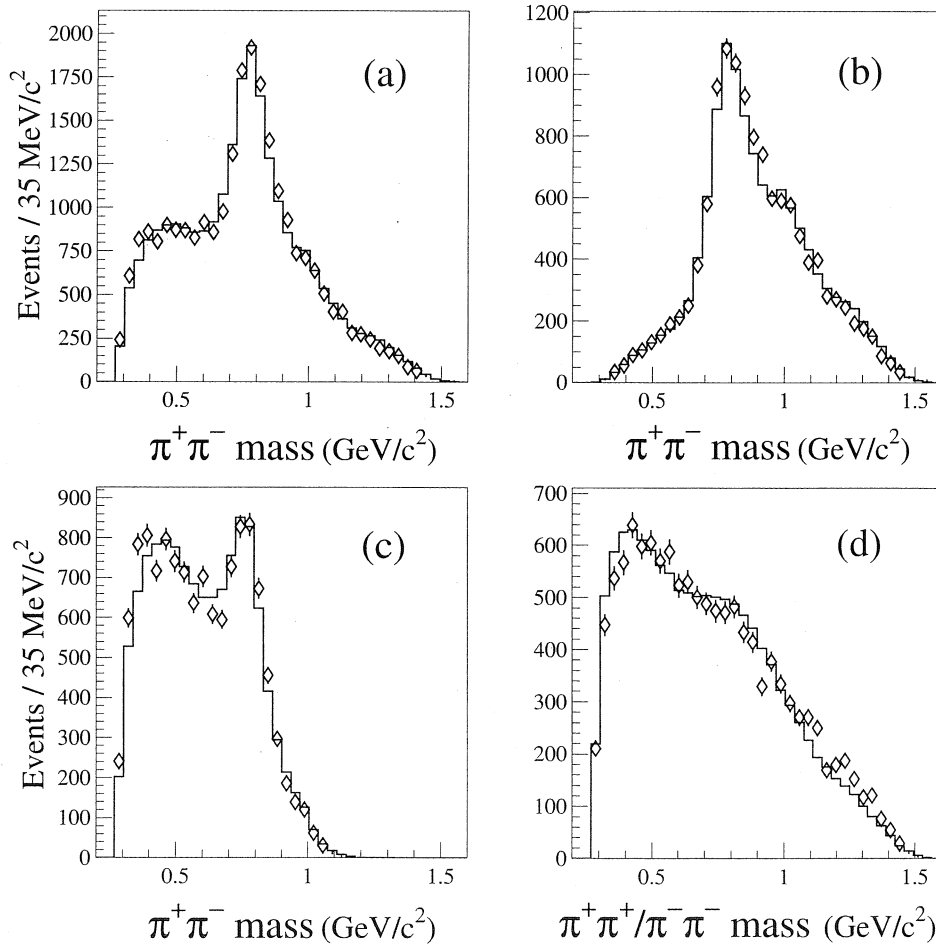

Figure 2. Comparison between data and the result of the best fit. In (a) all four $\pi^-\pi^+$ combinations are added. Entries from plot (a) are split into combinations with the highest and the lowest $\pi^-\pi^+$ mass: in (b) we show the $\pi^-\pi^+$ combinations with the highest mass, whereas in (c) we show the $\pi^-\pi^+$ combinations with the lowest mass; in (d) we show the $\pi^-\pi^-/\pi^+\pi^+$ mass distribution. In all plots the solid histogram is a projection of the fit.

Publications

A Hadronic Tile Calorimeter Report, Nucl. Inst. and Meth. [A409](#), 561 (1998).

Description and Performance of the FOCUS Calorimeter, Nucl. Inst. and Meth. [A434](#), 271 (1999).

A Measurement of Lifetime Differences in the Neutral D-meson System, Phys. Lett. [B485](#), 62 (2000).

Measurements of the Σ_c^0 and Σ_c^{++} Mass Splittings, Phys. Lett. [B488](#), 218 (2000).

Search for CP Violation in D^0 and D^+ Decays, Phys. Lett. [B491](#), 232 (2000).

Study of the Decay $D^0 \rightarrow K^+\pi^-$, Phys. Rev. Lett. [86](#), 2955 (2001).

Measurement of the Relative Branching Ratio $BR(\Xi_c^+ \rightarrow pK^-\pi^+) / BR(\Xi_c^+ \rightarrow \Xi^-\pi^+\pi^+)$, Phys. Lett. [B512](#), 277 (2001).

A Measurement of the Branching Ratios of D^+ and D_s^+ Hadronic Decays to Four-Body Final States Containing a K_s , Phys. Rev. Lett. [87](#), 162001 (2001).

Evidence for a Narrow Dip Structure at 1.9 GeV/c² in 3π⁺3π⁻ Diffractive Photoproduction, Phys. Lett. [B514](#), 240 (2001).

A New Measurement of the Ξ_c^+ Lifetime, Phys. Lett. [B523](#), 53 (2001).

Cerenkov Particle Identification in FOCUS, Nucl. Inst. and Meth. [A484](#), 270 (2002).

Reconstruction of Veos, Kinks, Ξ^- 's, and Ω^- 's in the FOCUS Spectrometer, Nucl. Instr. and Meth. [A484](#), 174 (2002).

Search for CP Violation in the Decays $D^+ \rightarrow K_s \pi^+$ and $D^+ \rightarrow K_s K^+$, Phys. Rev. Lett. [88](#), 041602 (2002).

Measurement of Natural Widths of Σ_c^+ and Σ_c^{++} Baryons, Phys. Lett. [B525](#), 205 (2002).

A High Statistics Measurement of the Λ_c^+ Lifetime, Phys. Rev. Lett. [88](#), 161801 (2002).

Evidence for New Interference Phenomena in the Decay $D^+ \rightarrow K^- \pi^+ \mu^+ \nu$, Phys. Lett. [B535](#), 43 (2002).

New Measurements of the D^0 and D^+ Lifetimes, Phys. Lett. [B537](#), 192 (2002).

Measurements of Relative Branching Ratios of Λ_c^+ Decays into States Containing Σ , Phys. Lett. [B540](#), 25 (2002).

Measurement of the D^+ and D_s^+ Decays into $K^+ K^- K^+$, Phys. Lett. [B541](#), 227 (2002).

New Measurements of the $\Gamma(D^+ \rightarrow \bar{K}^* \mu^+ \nu) / \Gamma(D^+ \rightarrow K^- \pi^+ \pi^+)$ and $\Gamma(D_s^+ \rightarrow \phi \mu^+ \nu) / \Gamma(D_s^+ \rightarrow \phi \pi^+)$ Branching Ratios, Phys. Lett. [B541](#), 243 (2002).

A New Measurement of the Ξ_c^0 Lifetime, Phys. Lett. [B541](#), 211 (2002).

New Measurements of the $D^+ \rightarrow \bar{K}^* \mu^+ \nu$ Form-Factor Ratios, Phys. Lett. [B544](#), 89 (2002).

Observation of a 1750-MeV/c² Enhancement in the Diffractive Photoproduction of $K^+ K^-$, Phys. Lett. [B545](#), 50 (2002).

A Study of the Cabibbo-Suppressed Decays $D^0 \rightarrow \pi^+ \pi^-$ and $D^0 \rightarrow K^+ K^-$, Phys. Lett. [B555](#), 167 (2003).

Charm System Tests of CPT and Lorentz Invariance with FOCUS, Phys. Lett. [B556](#), 7 (2003).

A Measurement of the Ω_c^0 Lifetime, Phys. Lett. [B561](#), 41 (2003).

Study of Hadronic Five-Body Decays of Charmed Mesons, Phys. Lett. [B561](#), 225 (2003).

The Target Silicon Detector for the FOCUS Spectrometer, Nucl. Instr. and Meth. [A516](#), 364 (2003).

Studies of Correlations Between D and anti-D Mesons in High-Energy Photo-production, Phys. Lett. [B566](#), 51 (2003).

Measurements of Ξ_c^+ Branching Ratios, Phys. Lett. [B571](#), 139 (2003).

Search for Rare and Forbidden 3-Body Decays of the Charmed Mesons D^+ and D_s^+ , Phys. Lett. [B572](#), 21 (2003).

Study of the Decay Mode $D^0 \rightarrow K^- K^- K^+ \pi^+$, Phys. Lett. [B575](#), 190 (2003).

Study of Hadronic Five-Body Decays of Charmed Mesons Involving a K_s^0 , Phys. Lett. [B586](#), 191 (2004).

Charm-AntiCharm Baryon Production Asymmetries in Photon Nucleon Interactions, Phys. Lett. [B581](#), 39 (2004).

Dalitz Plot Analysis of D_s^+ and D^+ Decay to $\pi^+ \pi^- \pi^+$ Using the K-Matrix Formalism, Phys. Lett. [B585](#), 200 (2004).

Measurement of Masses and Widths of Excited Charm Mesons D_2^* and Evidence for Broad States, Phys. Lett. [B586](#), 11 (2004).

New Measurements of the $D_s^+ \rightarrow \phi \mu^+ \nu$ Form Factor Ratios, Phys. Lett. [B586](#), 183 (2004).

Measurements of Six-Body Hadronic Decays of the D^0 Charmed Meson, Phys. Lett. B586, 21 (2004).

Measurement of the Ratio of the Vector to Pseudoscalar Charm Semileptonic Decay Rate $\Gamma(D^+ \rightarrow \bar{K}^*{}^0\mu^+\nu)/\Gamma(D^+ \rightarrow \bar{K}^0\mu^+\nu)$, Phys. Lett. B598, 33 (2004).

Study of the Doubly and Singly Cabibbo Suppressed Decays $D^+ \rightarrow K^+\pi^+\pi^-$ and $D_s^+ \rightarrow K^+\pi^+\pi^-$, Phys. Lett. B601, 10 (2004).

Measurements of the Q^2 Dependence of the $D^0 \rightarrow K^-\mu^+\nu$ and $D^0 \rightarrow \pi^-\mu^+\nu$ Form Factors, Phys. Lett. B607, 233 (2005).

Analysis of the Semileptonic Decay $D^0 \rightarrow \bar{K}^0\pi^-\mu^+\nu$, Phys. Lett. B607, 67 (2005).

Measurement of the Branching Ratio of the Decay $D^0 \rightarrow \pi^-\mu^+\nu$ Relative to $D^0 \rightarrow K^-\mu^+\nu$, Phys. Lett. B607, 51 (2005).

A Study of $D^0 \rightarrow K_s^0 K_s^0 X$ Decay Channels, Phys. Lett. B607, 59 (2005).

Study of the $D^0 \rightarrow K^+K^-\pi^+\pi^-$ Decay, Phys. Lett. B610, 225 (2005).

Measurement of the Doubly Cabibbo Suppressed Decay $D^0 \rightarrow K^+\pi^-$ and a Search for Charm Mixing, Phys. Lett. B618, 23 (2005).

Application of Genetic Programming to High Energy Physics Event Selection, Nucl. Instr. Meth. A551, 504 (2005).

Hadronic Mass Spectrum Analysis of $D^+ \rightarrow K^-\pi^+\mu^+\nu$ Decay and Measurement of the $K^*(892)^0$ Mass and Width, Phys. Lett. B621, 72 (2005).

A Measurement of the D_s^+ Lifetime, Phys. Rev. Lett. 95, 052003 (2005).

Study of Λ_c^+ Cabibbo Favored Decays Containing a Lambda Baryon in the Final State, Phys. Lett. B624, 22 (2005).

Search for T Violation in Charm Meson Decays, Phys. Lett. B622, 239 (2005).

Search for a Strongly Decaying Neutral Charmed Pentaquark, Phys. Lett. B622, 229 (2005).

Search for $\Lambda_c^+ \rightarrow PK^+\pi^-$ and $D_s^+ \rightarrow K^+K^+\pi^-$ Using Genetic Programming Event Selection, Phys. Lett. B624, 166 (2005).

A Non-Parametric Approach to the $D^+ \rightarrow \bar{K}^*{}^0\mu^+\nu$ Form-Factors, Phys. Lett. B633, 183 (2006).

Study of the Decay Asymmetry Parameter and CP Violation Parameter in the $\Lambda_c^+ \rightarrow \Lambda\pi^+$ Decay, Phys. Lett. B634, 165 (2006).

New Measurement of $\text{Br}(D^+ \rightarrow \rho^0\mu^+\nu) / \text{Br}(D^+ \rightarrow \bar{K}^*{}^0\mu^+\nu)$ Branching Ratio, Phys. Lett. B637, 32 (2006).

Search for a Pentaquark pK_s^0 , Phys. Lett. B639, 604 (2006).

A Non-Parametric Approach to Measuring the $K\pi$ Amplitudes in $D^+ \rightarrow K^+K^-\pi^+$ Decay, submitted to Phys. Letters, Hep/Ex-0612032 (2006).

Study of the $D^0 \rightarrow \pi^-\pi^+\pi^-\pi^+$ Decay, submitted to Phys. Rev. D., Hep/Ex-0701001 (2007).

Ph.D. Theses

M. Boschini, University of Milano, 1998.

F. Prelz, University of Milano, 1998.

A. Calandrino, University of Milano, 1999.

E. Casimiro, CINVESTAV, 1999.

E. Vaandering, University of Colorado, 2000.

L. Agostino, University of Pavia, 2000.

P. Dini, University of Milano, 2000.

M. Merlo, University of Pavia, 2000.

M. Mezzadri, University of Milano, 2000.

A. Rahimi, University of Illinois, 2000.

I. Segoni, University of Pavia, 2000.
 J. M. Link, University of California/Davis, 2001.
 C. Cawlfeld, University of Illinois/Urbana, 2001.
 B. R. Ko, Korea University, 2001.
 C. Pontoglio, INFN and University of Milano, 2001.
 S. Erba, INFN and University of Milano, 2001.
 L. Edera, INFN and University of Milano, 2001.
 S. Barberis, INFN and University of Milano, 2001.
 L. Milazzo, University of Milano, 2001.
 M. Rovere, University of Milano, 2001.
 E. Ramirez, University of Colorado, 2002.
 D. Engh, Vanderbilt University, 2002.
 M. Hosack, Vanderbilt University, 2002.
 J. W. Kwak, Korea University, 2002.
 A. Kryemadhi, Indiana University, 2002.
 A. Cerutti, INFN and University of Milano, 2002.
 R. Mitchell, University of Tennessee, 2002.
 A. Ettore, University of Pavia, 2002.
 G. Sani, University of Pavia, 2002.
 D. Pegna, University of Pavia, 2002.
 S. Carillo, CINVESTAV, 2003.
 E. Simili, University of Milano, 2003.
 L. Agostino, University of Colorado, 2004.
 A. Kryemadhi, Indiana University, 2004.
 A. Massafferri, CBPF, 2004.
 I. Segoni, University of Colorado, 2004.
 C. Uribe, BUAP, 2004.
 L. Edera, University of Milano
 S. Erba, University of Milano
 F. Vazquez, CINVESTAV, Mexico
 D. Pegna, University of Pavia

M.S. Theses

L. Mendez, University of Puerto Rico, 1997.
 D. Olaya, University of Puerto Rico, 1998.
 E. Ramirez, University of Puerto Rico, 1998.
 C. Rivera, University of Puerto Rico, 1998.
 E. Montiel, University of Puerto Rico, 1999.
 A. Mirles, University of Puerto Rico, 2000.
 C. Chang, Korea University, 2001.
 H. Hernandez, University of Puerto Rico, 2002.
 A. Paris, University of Puerto Rico, 2002.
 J. Quinones, University of Puerto Rico, 2002.
 E. Luiggi, University of Puerto Rico, 2003.
 M. Penagos, University of Puerto Rico, 2003.
 C. Castromonte, CBPF, 2004.

E-871

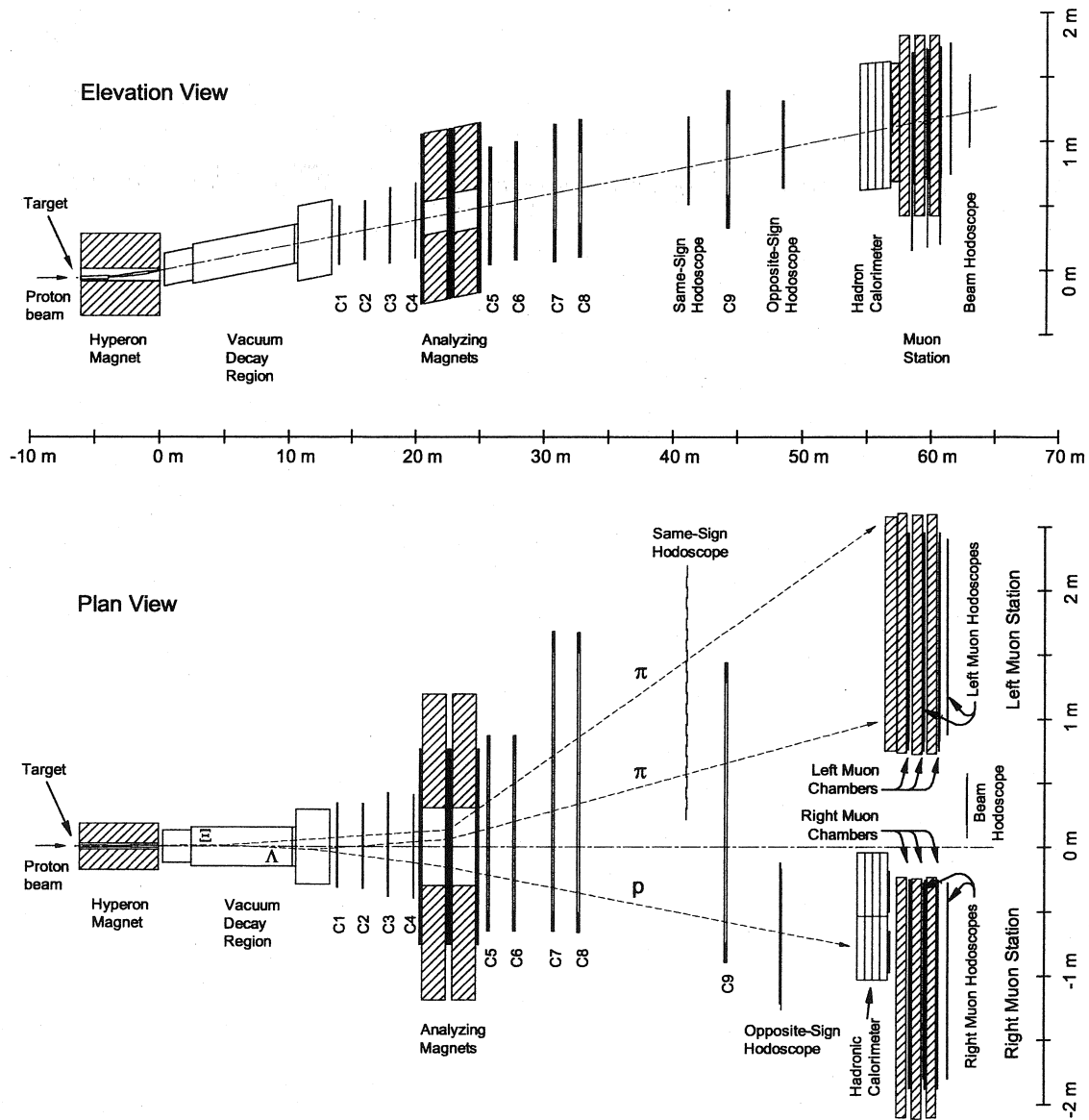

Elevation and plan views of the HyperCP spectrometer. The 1999 configuration is shown. Superimposed on the plan view are the charged tracks of a $\Xi \rightarrow \Lambda \pi \rightarrow \pi \pi \pi$ decay. For clarity, enclosures, support structures, and helium bags are not shown. Transverse dimensions have been exaggerated by a factor of ten.

E-871 (Dukes / Luk) HyperCP: Search for CP Violation in Charged-Hyperon Decays

Academia Sinica (Taiwan), UC/Berkeley, Fermilab, Guanajuato (Mexico), IIT, Lausanne (Switzerland), LBNL, Michigan, South Alabama, Virginia

Status: *Data Analysis*

Discovered about 40 years ago by Cronin and Fitch, who were awarded the Nobel Prize for their work, CP violation has remained a mysterious and puzzling aspect of particle physics. Its origin is unknown but its implications are profound: CP violation is thought to be responsible for the nearly absolute asymmetry between matter and antimatter in the universe, indeed, why there is any matter at all in the universe. But it is widely believed that the CP violation observed thus far (in only the decays of the K_L and B mesons) is too feeble to produce the asymmetry between matter and antimatter in the universe. Other sources are needed, perhaps from physics beyond that in the Standard Model. To quote Bigi and Sanda from their recent book, *CP Violation*:

"We are willing to stake our reputation on the prediction that dedicated and comprehensive studies of CP violation will reveal the presence of New Physics."

The goal of HyperCP is to search for new sources of CP violation in the decays of charged Ξ and Λ hyperons. These are sensitive to certain sources of CP violation that kaon decays, for example, are not. The signature for the CP asymmetry is a difference between the angular distributions of the Λ and $\bar{\Lambda}$ decay products, where the Λ and $\bar{\Lambda}$ have been produced from Ξ^- and $\bar{\Xi}^+$ decays. The HyperCP spectrometer was designed to have a sensitivity in the CP asymmetry of about 2×10^{-4} , three orders of magnitude better than the experimental limit at the time. Current theoretical predictions range from several times 10^{-3} in some supersymmetric models of CP violation, to about 10^{-5} in Standard Model calculations.

The HyperCP sensitivity goals demand a large number of events, and hence an extremely high-rate spectrometer was built in the short space of two years, one capable of recording up to 100,000 events per second. The spectrometer accumulated then the largest dataset ever taken – 231 billion events – in two running periods: 1997 and 1999. The primary event reconstruction (of over 30,000 tapes) was done on the Fermilab computer farms and completed in the summer of 2001. This work involved reconstructing a dataset 25 times larger than the total amount of data on all of the Web sites in the world at the time. It resulted in by far the largest sample of hyperon decays ever taken as well as a large sample of charged-kaon decays.

The scope of the physics topics that HyperCP addresses goes beyond CP violation in hyperon decays. The complete HyperCP physics menu includes: 1) a high-precision search for CP violation in charged Ξ and Λ decays; 2) the

measurement of the branching ratios in the flavor-changing neutral-current (FCNC) decays: $K^+ \rightarrow \pi^+\mu^+\mu^-$ and $K^- \rightarrow \pi^-\mu^+\mu^-$; 3) the search for the θ^+ (1.54) pentaquark; 4) the search for the decay $\Sigma^+ \rightarrow p\mu^+\mu^-$; 5) the search for the lepton-number-violating decay $\Xi^- \rightarrow p\mu^-\mu^-$; 6) the search for the $|\Delta S| = 2$ decays $\Omega^- \rightarrow \Lambda\pi^-$, and $\Xi^0 \rightarrow p\pi^-$; 7) the precise measurement of the Ω^- and $\bar{\Omega}^+$ α decay parameters and the corresponding CP asymmetry; 8) the precise measurement of the α , β , and γ parameters in $\Xi^- \rightarrow \Lambda\pi^-$ decays; 9) the measurement of the Λ - π^- strong phase shift; 10) the measurement of the branching ratio $\Omega^- \rightarrow \Xi^-\pi^+\pi^-$; and 11) the search for the FCNC decays $\Omega^- \rightarrow \Xi^-\mu^+\mu^-$ and $\Omega^- \rightarrow \Xi^-e^+e^-$.

The analysis of the data has produced fourteen refereed publications. A few highlights follow. Results from the main goal of the experiment, the search for CP violation in charged Ξ and Λ hyperon decays, has recently been published. No CP violation was found in an analysis of 17% of the dataset, a factor of 20 improvement over the best previous result. This new measurement is beginning to constrain some supersymmetric predictions of the asymmetry. HyperCP has reported the first unambiguous evidence of parity violation in the decays of the Ω^- and the $\bar{\Omega}^+$ from an analysis of about five million Ω^- and two million $\bar{\Omega}^+$ events. Of the various searches for rare and forbidden hyperon decays HyperCP has made, perhaps the most interesting is the evidence for the decay $\Sigma^+ \rightarrow p\mu^+\mu^-$. The three found events constitute the smallest branching ratio ever observed in a baryon decay. These events have a narrow dimuon mass, suggesting that perhaps the decay proceeds by a hitherto unknown neutral intermediate state of mass 214.3 ± 0.5 MeV/ c^2 . HyperCP also reported one of the first high-statistics precision mass resolution non-observations of the θ^+ (1.54) pentaquark. Other searches for rare and forbidden hyperon decays, such as the search for $\Delta S = 2$ decays and lepton-number violation, are many orders of magnitude more sensitive than previous results.

Although the HyperCP spectrometer was designed to detect hyperons, it accumulated an enormous sample of charged-kaon decays. The collaboration's first publication, a new measurement of the branching ratio of the FCNC decay $K^+ \rightarrow \pi^+\mu^+\mu^-$, as well as the first observation of the conjugate decay, $K^- \rightarrow \pi^-\mu^+\mu^-$, resolved an outstanding disagreement between two BNL experiments for this important test of chiral perturbation theory.

Publications

A High-Throughput Data Acquisition System for the HyperCP Experiment, Y.-C. Chen et al., Nucl. Instr. and Meth. A455, 424 (2000).

Upgraded DAQ System for the HyperCP Experiment, C. White et al., Nucl. Instr. and Meth. A474, 67 (2001).

Tripling the Data Set for the HyperCP Experiment, C. White et al., IEEE Trans. Nucl. Sci. 49, 568 (2002).

Observation of the Decay $K^- \rightarrow \pi^-\mu^+\mu^-$ and Measurements of the Branching Ratios for $K^\pm \rightarrow \pi^\pm\mu^+\mu^-$, H. K. Park et al., Phys. Rev. Lett. 88, 111801 (2002).

New Measurement of $\Xi^- \rightarrow \Lambda\pi^-$ Decay Parameters, M. Huang et al., Phys. Rev. Lett. 93, 011802 (2004).

High Statistics Search for the θ^+ (1.54) Pentaquark State, M. J. Longo et al., Phys. Rev. D70, 111101 (R) (2004).

Search for CP Violation in Charged- Ξ and Λ Hyperon Decays, T. Holmstrom et al., Phys. Rev. Lett. 93, 262001 (2004).

Evidence for the Decay $\Sigma^+ \rightarrow p\mu^+\mu^-$, H. K. Park et al., Phys. Rev. Lett. 94, 021801 (2005).

Measurement of the α Asymmetry Parameter for the $\Omega^- \rightarrow \Lambda K^-$ Decay, Y. C. Chen et al., Phys. Rev. D71, 051102 (R) (2005).

Search for $\Delta s=2$ Nonleptonic Hyperon Decays, C. G. White et al., Phys. Rev. Lett. 94, 101804 (2005).

HyperCP: A High-Rate Spectrometer for the Study of Charged Hyperon and Kaon Decays, R. A. Burnstein et al., Nucl. Instr. and Meth. A541, 516 (2005).

Search for the Lepton-Number-Violating Decay $\Xi^- \rightarrow p\mu^-\mu^-$, D. Rajaram et al., Phys. Rev. Lett. 94, 181801 (2005).

Observation of Parity Violation in the $\Omega^- \rightarrow \Lambda K^-$ Decay, L. C. Lu, et al., Phys. Lett. B617, 11 (2005).

Measurement of the Asymmetry in the Decay $\bar{\Omega}^+ \rightarrow \bar{\Lambda} K^+ \rightarrow \bar{p}\pi^+ K^+$, L. C. Lu et al., Phys. Rev. Lett. 96, 242001 (2006).

Theses

- D. Rajaram, University of Virginia (1996)
- Z. del Cid, University of Guanajuato (2000)
- M. Morales, University of Guanajuato (2000)
- W.-S. Choong, University of California/Berkeley (2000)
- N. Leros, Université de Lausanne (2001)
- D. Rajaram, Illinois Institute of Technology (2002)
- M. Huang, University of Virginia (2003)
- T. Holmstrom, University of Virginia (2003)

E-872 Spectrometer Plan View

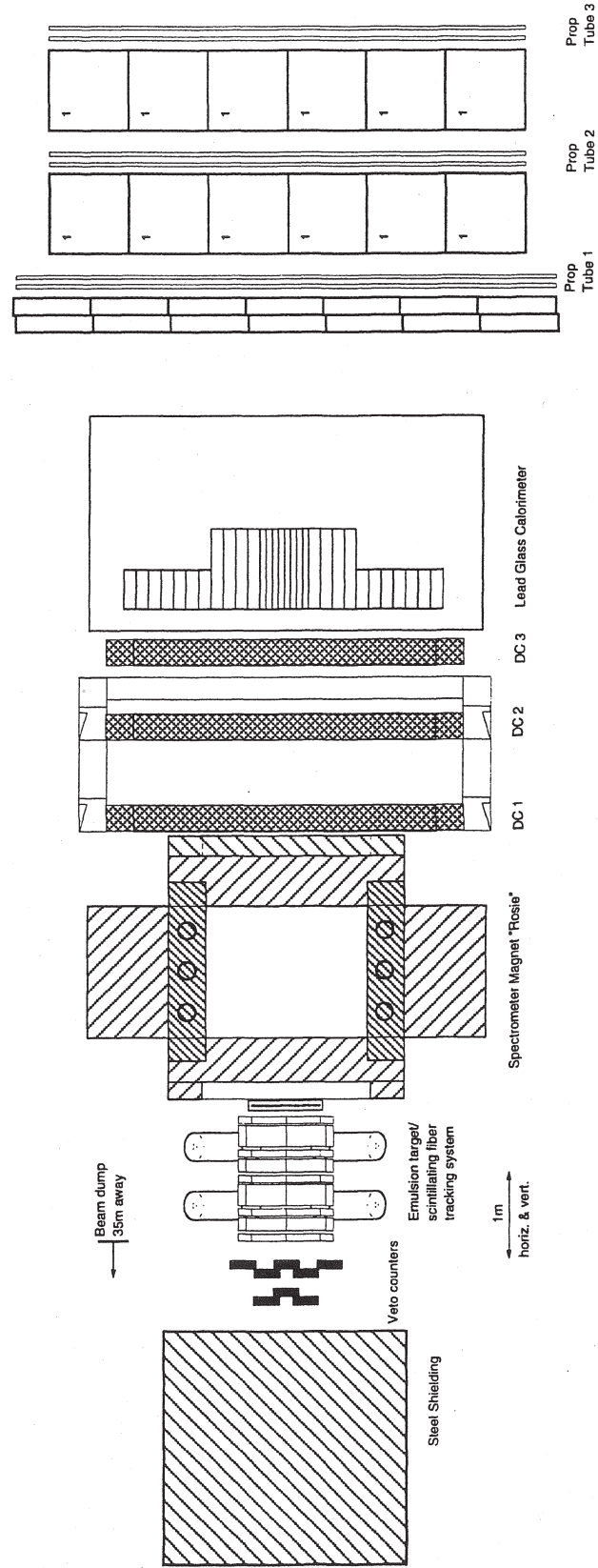

E-872 (Tzanakos / Paolone) Direct Observation of the Tau-Neutrino

*Aichi (Japan), Athens (Greece), UC/Davis, Changwon Nat'l (Korea),
 Collège de France (France), Fermilab, Gyeongsang (Korea), Kansas State,
 Kobe (Japan), Kon-kuk (Korea), Korean Nat'l (Korea), Minnesota,
 Nagoya (Japan), Osaka Sci. Ed. Inst. (Japan), Pittsburgh, South Carolina,
 Toho (Japan), Tufts, Utsunomiya (Japan)*

Status: <i>Data Analysis</i>

Since the discovery of the tau lepton in 1975, the desire to detect the ν_τ was strong, but the experiments that were proposed were technically very challenging and expensive. The use of emulsion, as active targets, in conjunction with its specially designed beam, has enabled DONUT to overcome most of the technical problems. Although there was strong experimental and theoretical evidence for the existence of a third neutrino, its direct confirmation was an important result. In July 2000, after three years of analysis, four events identified as tau-neutrino interactions were found in a sample of 203 neutrino interactions in an emulsion target/detector. These results were published early in 2001. A new upper limit to the tau-neutrino magnetic moment was also published using this data.

Tau neutrinos, produced in the beam dump using 800 GeV protons, originated mostly in the leptonic decay of the D_s (charm-strange) meson in the decay sequence $D_s \rightarrow \tau + \nu_\tau$ and $\tau \rightarrow \nu_\tau + X$. Both the D_s and the daughter τ decay in the dump, each decay producing one ν_τ . Their charged-current interactions are found directly by observing τ lepton production and its subsequent decay in the emulsion target. The data run was from April to September 1997 and a total of 4.5×10^{17} protons were used in the beam dump to make neutrinos.

Several years were spent in developing emulsion scanning techniques necessary for insuring high efficiency in locating the interactions in the emulsion. Because the emulsion targets were very thick, 6 cm, the older method of following tracks from the spectrometer was less reliable because of secondary interactions, electron showers, and scattering. A new method was employed for most of the events. In this method, automatic emulsion scanning stations were programmed to find all tracks in a *volume* of emulsion surrounding the interaction prediction. These data was then processed by finding all vertices (at least two tracks) in this volume. This powerful method was possible only because of the increased speed of the emulsion scanning stations. The spatial precision achieved for the emulsion data was 0.3 microns in the transverse coordinates, which provided a powerful rejection against background signals.

Presently, the collaboration is completing the analysis on the final set of events (~600 located events). A final paper based on the complete sample will be submitted in spring 2007.

MINOS (Main Injector Neutrino Oscillation Search) Far Detector

Fermilab

- 25,800 m² Active Detector Planes
- 4 cm wide solid scintillator strips
- WLS fiber readout

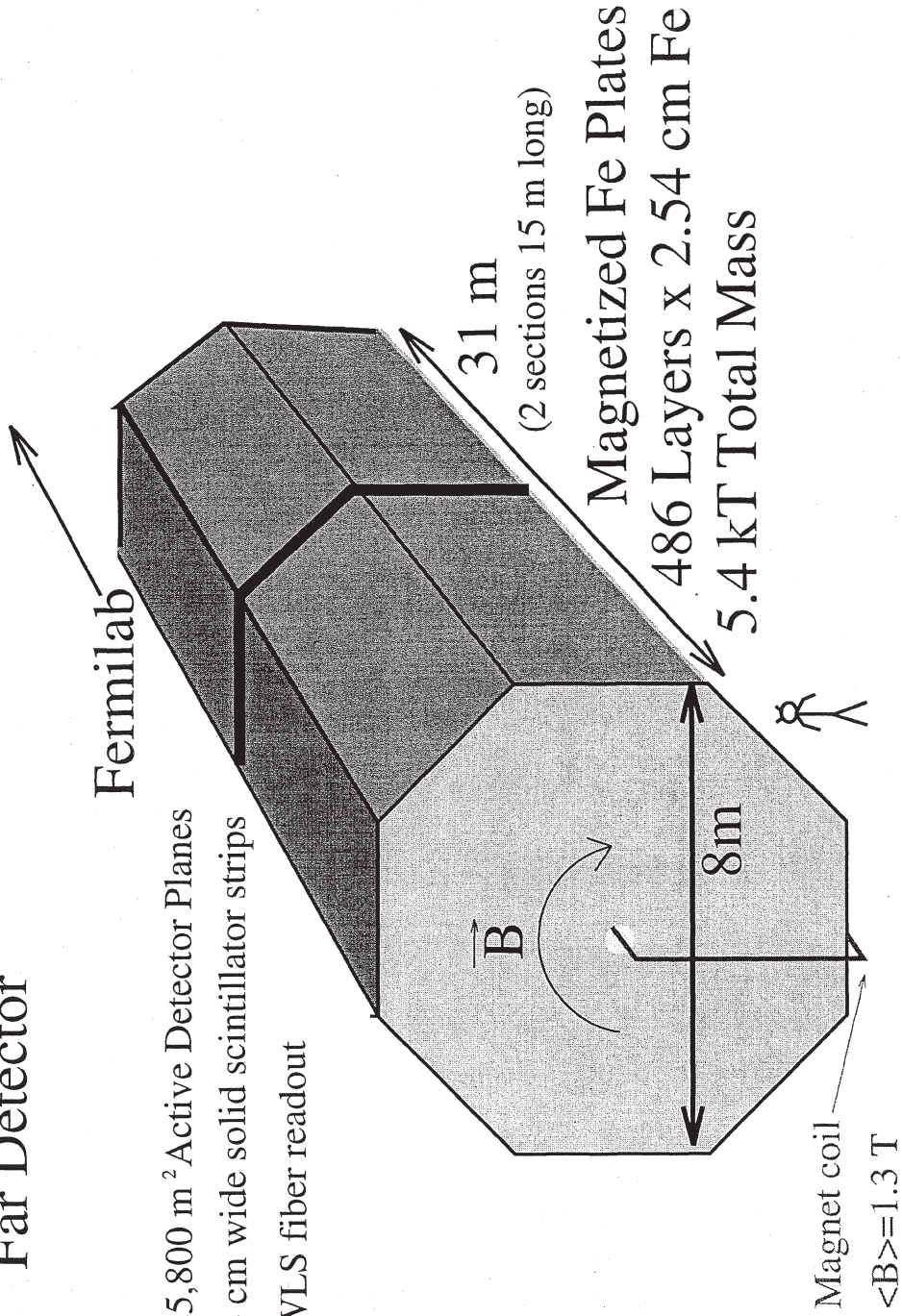

31 m
(2 sections 15 m long)

Magnetized Fe Plates
486 Layers x 2.54 cm Fe
5.4 kT Total Mass

8m

Magnet coil
 $\langle B \rangle = 1.3 \text{ T}$

**E-875 / 934 (Plunkett / Wojcicki) Main Injector
Neutrino Oscillation Search (MINOS)**

*ANL, Athens (Greece), Benedictine, BNL, Caltech, Cambridge (United Kingdom),
Campinas (Brazil), Fermilab, Collège de France (France), Harvard, IHEP/Protvino (Russia),
IIT, Indiana, ITEP (Russia), Lebedev (Russia), Minnesota, Minnesota/Duluth,
Oxford (United Kingdom), Pittsburgh, Rutherford (United Kingdom), São Paulo (Brazil),
South Carolina, Stanford, Sussex (United Kingdom), Texas A&M, Texas/Austin, Tufts,
Univ. College London (United Kingdom), Western Washington, William & Mary, Wisconsin*

Status: Data-taking

The goal of the Main Injector Neutrino Oscillation Search (MINOS) experiment is a comprehensive investigation of neutrino oscillations, down to a level of about 10^{-3} eV² in Δm^2 and 10^{-2} in $\sin^2(2\theta)$, using neutrinos produced by the Fermilab Main Injector beam and a large detector located at the Soudan Mine in Minnesota, some 735 km away. A "near detector" located at Fermilab monitors the beam and enables a comparison to be made between neutrino interactions in detectors at two quite different distances from the neutrino source.

Neutrino physics presents today one of the most promising avenues to probe for extensions of the Standard Model. A priori, no fundamental reason exists why neutrinos should have zero mass or why there should be no mixing between different neutrino species. Thus, the existence of neutrino oscillations is quite plausible, maybe even likely, on theoretical grounds. The existence of this phenomenon has received first experimental indications from the observations of a deficit of solar neutrinos and from the ν_μ/ν_e anomaly in the interactions of atmospheric neutrinos observed by large underground experiments. Detailed observations by the SuperKamiokande experiment on the angular distributions of atmospheric neutrinos provided strong support for the oscillations interpretation and reduced the range of possible oscillation parameters. The accelerator K2K experiment in Japan has confirmed that conclusion. The SNO experiment in Canada looking at solar neutrino interactions in heavy water and the KamLAND experiment in Japan looking at reactor neutrinos have provided not only convincing evidence for solar neutrino oscillations but also quantitative understanding of the oscillation parameters for that phenomenon.

This MINOS experiment makes use of several independent measurements to investigate neutrino oscillations. The comparison of rates and energy spectra at the two detectors for the ν_μ charged-current events has conclusively verified the oscillation hypothesis and measured the oscillation parameters, Δm^2 and $\sin^2(2\theta)$. The comparison of NC and CC interaction rates will be able to determine the relative contributions of the modes $\nu_\mu \rightarrow \nu_\tau$ and $\nu_\mu \rightarrow \nu_{\text{sterile}}$. The study of event shapes will allow us to search for the $\nu_\mu \rightarrow \nu_e$ mode and to improve on the CHOOZ limit by about a factor of two if no events are found.

The MINOS experiment uses two very similar detectors, one at Fermilab and one in Minnesota's Soudan mine, 735 km away. Both detectors consist of assemblies of 1 inch-thick magnetized steel planes, interleaved with planes of 4 cm wide strips of plastic scintillator. The 1 kT near detector at Fermilab has 4.8 m wide steel planes; the 5.4 kT far detector at Soudan has 8 m wide planes arranged in two supermodules. The steel planes in both detectors are magnetized toroidally with an average field of 1.3 T. In the absence of oscillations, the far detector would record about 1,500 charged-current ν_μ interactions annually using the low-energy beam configuration.

The existing underground physics laboratory in the Soudan Mine has been expanded to house the new MINOS far detector. Excavation of the new laboratory began in May 1999, and installation of the far detector began in July 2001. The far detector was completed in July 2003, when it began taking data on cosmic rays and atmospheric neutrinos. Site excavation for the construction of the underground NuMI beam facility at Fermilab was completed in November 2002 and outfitting of the underground enclosures and construction of service buildings was finished in early 2004. The installation of beamline components was completed in December 2004. Neutrino beam commissioning began in January 2005 and data-taking, with both the near detector and the far detector, began in March 2005. The MINOS collaboration published its initial measurement of $\nu_\mu \rightarrow \nu_\tau$ oscillation parameters in November 2006 (Phys. Rev. Lett. 97, 191801).

Status and Accomplishments

November 1998: NuMI/MINOS Project baselined by the Department of Energy.
 February 1999: DOE CD-3a (start limited construction) approved.
 May 1999: DOE CD-3b (continue construction at Fermilab) approved.
 May 1999: Excavation of far detector lab started at Soudan.
 October 1999: Near detector electronics design upgraded for fast extraction.
 March 2000: Excavation of NuMI beamline tunnels and halls started at Fermilab.
 November 2000: Excavation of far detector cavern completed at Soudan.
 July 2001: Beneficial occupancy of far detector cavern.
 July 2001: Installation of MINOS far detector begins.
 October 2001: First run of MINOS calibration detector completed in CERN test beam.
 January 2002: Tunnel boring machine excavation completed.
 March 2002: First atmospheric neutrino event recorded by far detector.
 April 2002: NuMI beam decay pipe installation begins.
 July 2002: Supermodule 1 magnet coil installed and commissioned.
 August 2002: Near detector hall excavation completed.
 September 2002: Second calibration detector run completed in CERN test beam.
 October 2002: NuMI target hall excavation completed.
 November 2002: Underground excavation completed at Fermilab.
 May 2003: Five-year run plan proposal submitted.
 July 2003: MINOS far detector and veto shield installation completed.

- July 2003: Begin atmospheric neutrino and antineutrino data acquisition.
October 2003: Third and final calibration detector run completed at CERN.
October 2003: Beneficial occupancy of NuMI Pre-target and Target Hall areas.
March 2004: Beneficial occupancy of the Near Detector Hall.
April 2004: Begin installation of Near Detector.
June 2004: First cosmic-ray muon tracks observed in Near Detector.
August 2004: Complete installation of Near Detector.
November 2004: Complete installation of NuMI beamline.
December 2004: First protons extracted into NuMI beamline to hadron absorber.
January 2005: First neutrino events in Near Detector.
March 2005: Data-taking begins with NuMI beam neutrinos.
March 2005: First NuMI neutrino events recorded by the far detector
December 2005: Total physics exposure equals 1.10×10^{20} protons on the NuMI target at the end of 2005.
April 2006: Paper on separated ν_μ and $\bar{\nu}_\mu$ atmospheric neutrino events published in Phys. Rev. D.
November 2006: Paper on ν_μ disappearance published in Phys. Rev. Letters.
December 2006: Total physics exposure equals 2.24×10^{20} protons on the NuMI target at the end of 2006.

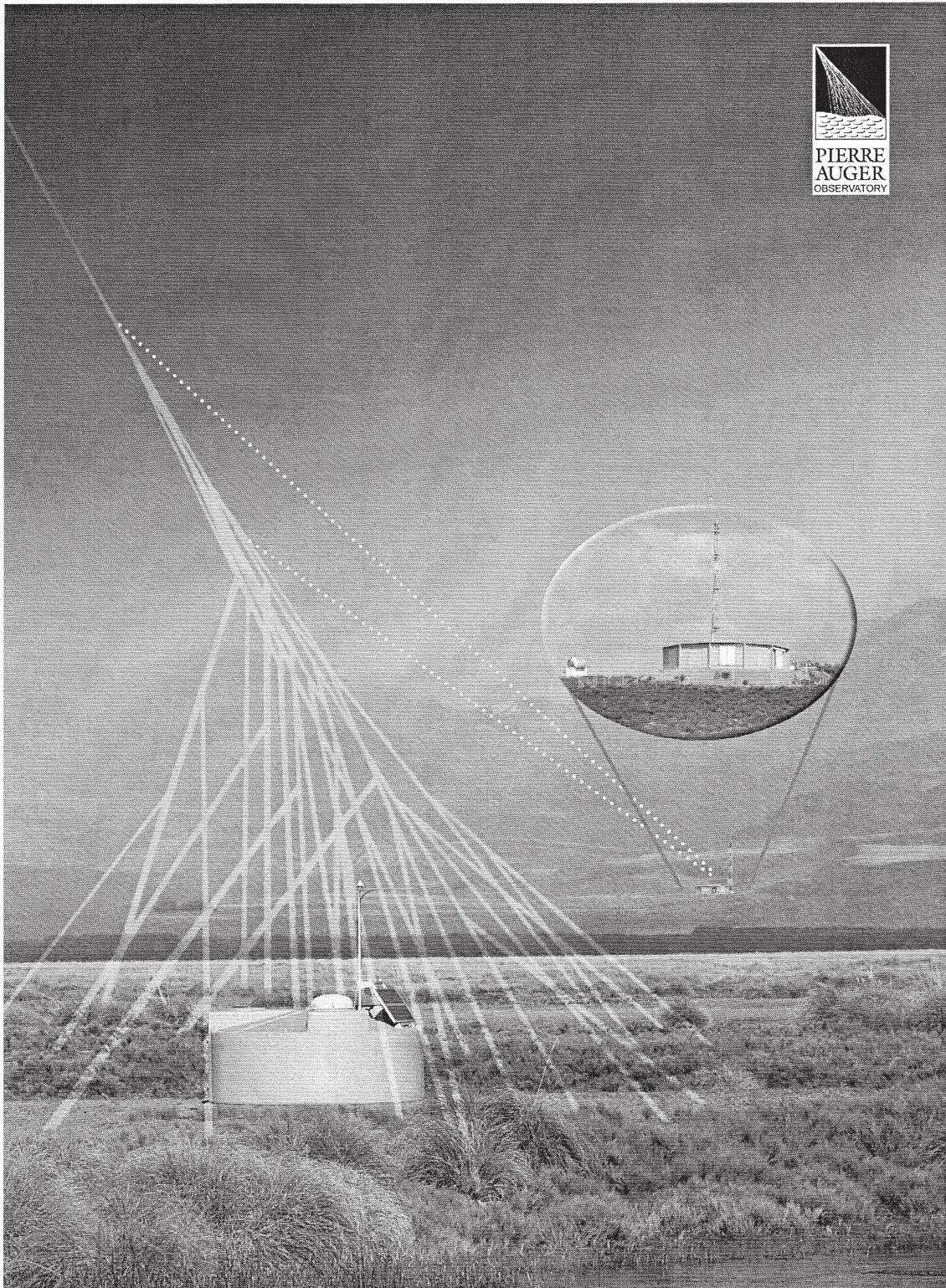

Illustration of the detector systems used in the Pierre Auger Observatory. The surface array consists of 1600 self-contained particle detectors spaced on a 1.5 km grid over the surface. The development of air showers is observed on dark nights using air fluorescence telescopes (inset).

E-881 (Mantsch) **The Pierre Auger Project - A Study of the Highest-Energy Cosmic Rays**

Fermilab
(and institutions in 16 countries)

Status: *Data-Taking*

Over the past thirty years cosmic ray air shower detectors have recorded a number of events with energies greater than 10^{20} eV. These super-high-energy events are extraordinary for two reasons. First, there are no known acceleration mechanisms that can produce particles of these energies. Second, the attenuation length for cosmic rays with energy greater than 1.5×10^{19} eV is less than about 30 Mpc. This attenuation (known as the Greisen-Zatsepin-Kuzmin cut off) results from the interaction of cosmic ray particles with the cosmic microwave background. Thus particles of these energies can only reach the earth if they are produced relatively nearby. The high magnetic rigidity of these particles also means that they suffer little deflection from magnetic fields in the galaxy and in intergalactic space. As yet none of the particles observed points back to a possible astrophysical source within the distance limit imposed by the background radiation.

The Pierre Auger Project is a broadly-based international effort by 16 countries to make a high statistics, full sky study of cosmic rays at the highest energies to probe the origin of these, the most energetic particles yet observed in nature. Two air shower detectors will be built, one to be placed in the Northern Hemisphere and one in the Southern Hemisphere. Each installation will consist of an array of 1600 particle detectors spread over 3000 km². Each installation will also have 24 atmospheric fluorescence telescopes viewing the volume above the surface array. The surface array records the shower particle distribution at the surface while the fluorescence detectors record the development of the shower cascade. These two air shower detector techniques working together form a powerful instrument for this research. The detectors perform very well indeed, better than expected. It now appears likely we will be able to reconstruct air showers at zenith angles almost to the horizon. This enhanced aperture will not only increase the experiment's cosmic ray event rate but also its physics possibilities including neutrinos and other exotics that approach from near the horizon.

Construction of the southern site of the Auger Observatory is approaching completion. More than 1200 (of 1600) surface detector stations are deployed and 1080 operational, while all of the 24 fluorescence telescopes are installed and operational. Completion is expected in 2007. Two papers containing first results on anisotropies in the direction of the galactic center and a new limit on photon primaries are in publication. Several more physics and technical papers are in preparation.

E-885

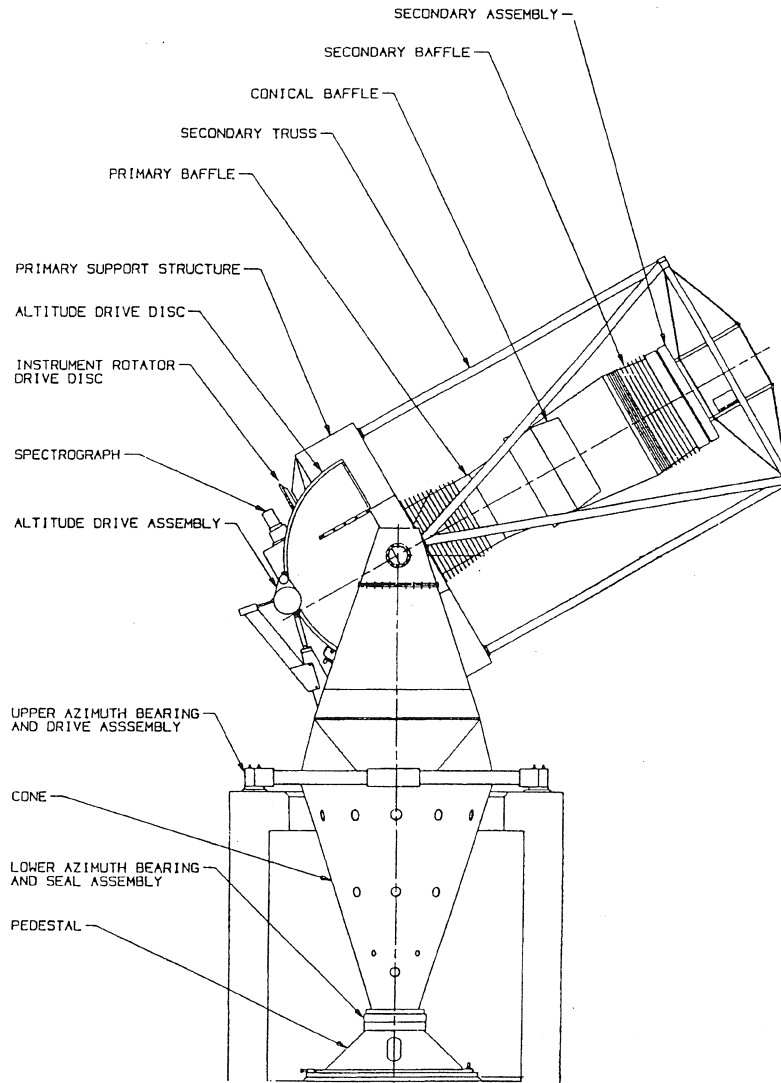

E-885 / 949 (Kent) Sloan Digital Sky Survey

Fermilab

*(and American Museum of Natural History, Astrophysical Institute Potsdam [Germany],
Basel [Switzerland], Cambridge [United Kingdom], Case Western Reserve, Chicago, Drexel,
Institute for Advanced Study, Japan Participation Group [Japan], Johns Hopkins,
Joint Institute for Nuclear Astrophysics [Michigan State/Notre Dame/Chicago],
Kavli Institute [SLAC/Stanford], Korean Scientist Group [Korea], LAMOST [China],
LANL, Max-Planck/Garching [Germany], Max-Planck/Heidelberg [Germany],
New Mexico State, Ohio State, Pittsburgh, Portsmouth [United Kingdom],
Princeton, US Naval Observatory, Washington)*

Status: E-885: <i>Data Analysis</i> E-949: <i>Data-Taking</i>

The Sloan Digital Sky Survey (SDSS) intends to reveal large-scale structure in the distribution of galaxies with a spatial extent and precision in its determination that greatly exceed current capabilities. This map of the large-scale distribution of galaxies will serve to constrain models for the origin and evolution of that structure, and thereby to address fundamental questions in cosmology and astrophysics, including the amount and distribution of mass with respect to the luminous material in the universe.

A second phase of the project, SDSS-II, commenced in July 2005. SDSS-II has three components. The first, called LEGACY, is completing the SDSS survey of the extragalactic universe, obtaining images and distances of nearly a million galaxies and quasars over a contiguous swath of sky in the Northern Hemisphere and over selected swaths in the Southern Hemisphere. The second, called SEGUE (the Sloan Extension for Galactic Understanding and Exploration), is mapping the structure and stellar makeup of the Milky Way Galaxy, gathering data on how the Milky Way formed and evolved. The final component is an intensive study of type Ia supernovae, which can be used to precisely measure distances and map the rate of expansion of the universe. The goal of this study is to verify and quantify the existence of cosmological dark energy.

A wide-field 2.5-m telescope (see adjacent figure) dedicated to this project is operating at Apache Point Observatory (APO), near Sunspot, New Mexico. The imaging system and the spectroscopic system share the same focal plane via an instrument exchange mechanism (see Figures 1 and 2). The unique data products include the multi-band imaging survey (there are five wave bands covering the visible spectral range, the data from which are collected nearly simultaneously), and the inclusion of quasar candidates along with the galaxies.

In connection with the planning for SDSS-II, the survey goals for sky coverage in imaging and spectroscopy were re-baselined starting in January 2005. The current goals for LEGACY are 1418 square degrees of imaging and 744 plates (or 450,000 objects) for spectroscopy. The goals for SEGUE are 3572 square degrees of imaging and 660 plates (or 267,000 objects) for spectroscopy.

The goals for Supernovae are 150-180 well measured objects suitable for cosmological studies.

Observing was conducted every month in 2006 except for a six-week shutdown during the summer months. Through the end of 2006, the survey has collected 86% of its three-year baseline imaging data and 50% of its spectroscopic baseline data. The lag in spectroscopic data collection is a reflection of the fact that the spectroscopic survey inherently lags the imaging survey by about a year. A total of 2555 plates have been designed and drilled from the processed imaging data. Including reprocessing, about 150 terabytes of data have been processed.

One release of data to the public, DR5, was made in 2006. This release includes essentially all imaging and spectroscopic data obtained up to June, 2005. The data volume is about 15 terabytes and consists of images of 215 million objects and spectra of 1 million galaxies, quasars and stars. The distribution is done via file servers that are hosted and accessed through Fermilab (the Data Archive Server) and a database that is cohosted at both Fermilab and Johns Hopkins University (the Catalog Archive Server). The next data release is scheduled for 2007.

The SDSS collaboration has published over 26 papers in refereed journals over the past year. Additionally, over 50 papers have been published by other members of the astronomical community based upon public SDSS data over the same time period. Sample highlights of results obtained in the past year include the discovery of several distant galaxies magnified by the effects of gravitational lensing from dark matter in nearby galaxies and the discovery of new satellite galaxies, including some that have been shredded by tidal forces, in the halo of the Milky Way. Current cosmological theories for a universe with 25% dark matter at present predict the existence of large numbers of such satellites, which are difficult to detect.

Fermilab continues to be responsible for the maintenance of the data acquisition systems and certain hardware systems at APO. Fermilab also operates the data processing systems, oversees improvements and upgrades to the data processing pipelines and hardware systems, and exports data distribution to collaboration members and the public.

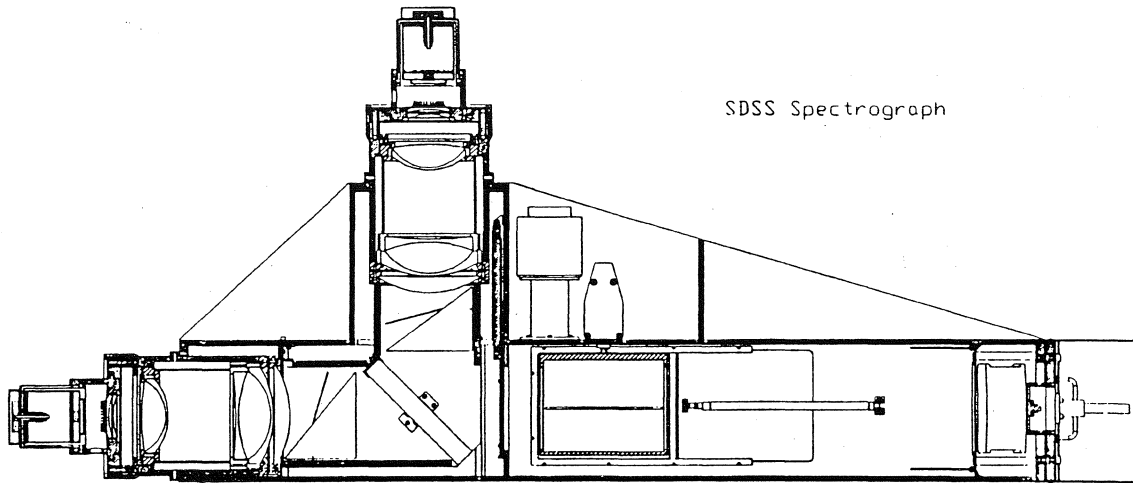

Figure 1

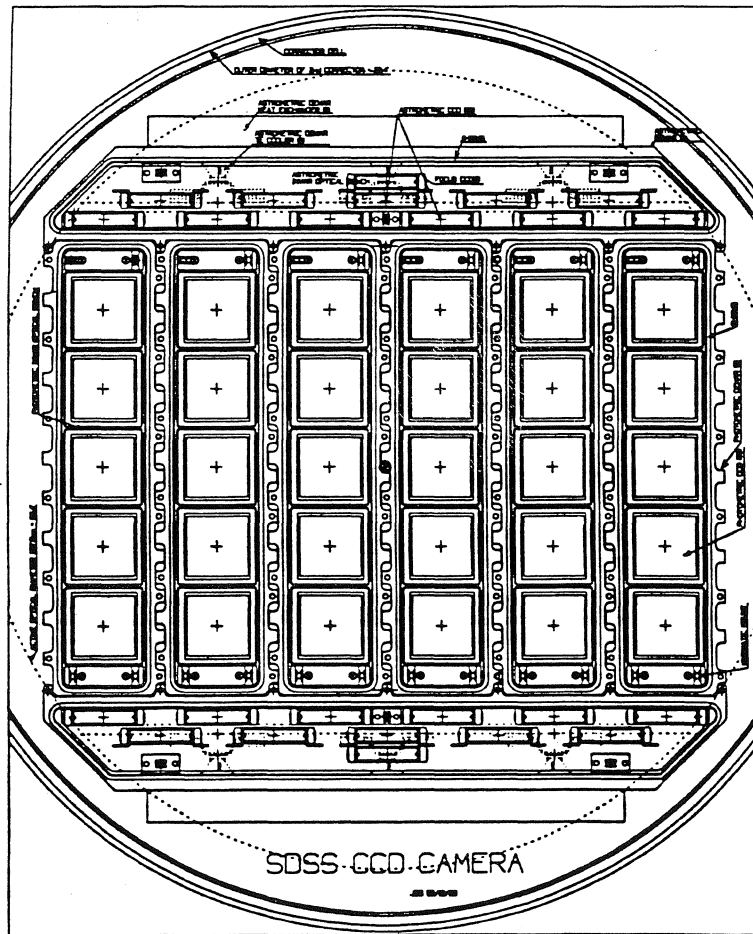

Figure 2

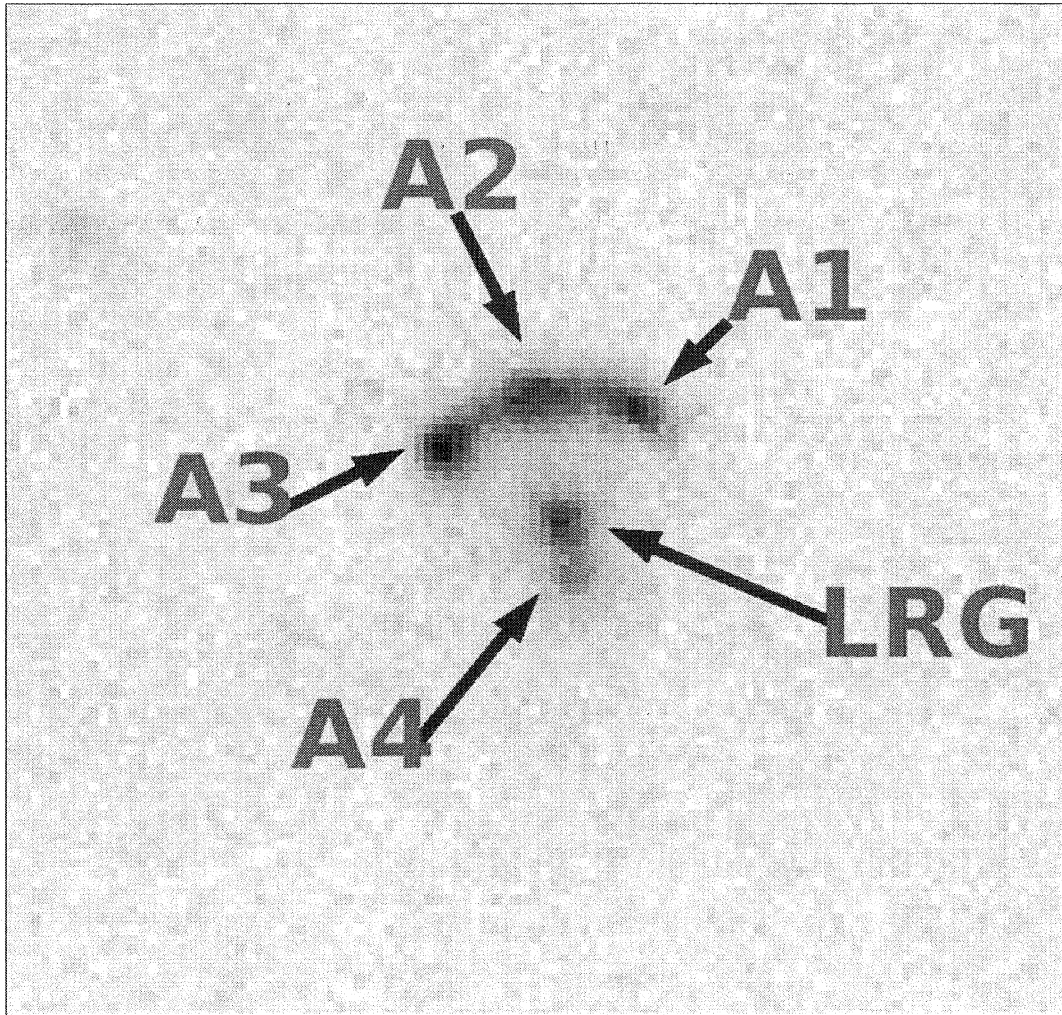

Figure 3. Image of an object known as the "8 O'Clock arc," discovered by SDSS scientists this past year. A distant galaxy (redshift $z=2.7$) appears as four elongated images (A1 to A4) surrounding a nearby, low-redshift galaxy (LRG) that is filled with dark matter. The dark matter acts as a natural telescope (albeit one with severe barrel distortion), magnifying the distant galaxy by more than a factor of 10.

Publications

High-Redshift Quasars Found in Sloan Digital Sky Survey Commissioning Data III. A Color-Selected Sample at $i^* < 20$ in the Fall Equatorial Stripe, X. Fan et al., *Astronomical Journal* 121, 31 (2001).

High-Redshift Quasars Found in Sloan Digital Sky Survey Commissioning Data IV. Luminosity Function from the Fall Equatorial Stripe Sample, X. Fan et al., *Astronomical Journal* 121, 54 (2001).

High-Redshift Quasars Found in Sloan Digital Sky Survey Commissioning Data V. Hobby-Eberly Telescope Observations, D. P. Schneider et al., *Astronomical Journal* 121, 1232 (2001).

The First Hour of Extragalactic Data of the Sloan Digital Sky Survey Spectroscopic Commissioning: The Coma Cluster, F. Castander et al., *Astronomical Journal* 121, 2331 (2001).

- Colors of 2625 Quasars at $0 < z < 5$ Measured in the Sloan Digital Sky Survey Photometric System, G. Richards et al., *Astronomical Journal* 121, 2308 (2001).
- The Luminosity Function of Galaxies in SDSS Commissioning Data, M. Blanton et al., *Astronomical Journal* 121, 2358 (2001).
- Detection of Massive Tidal Tails around the Globular Cluster Palomar 5 with Sloan Digital Sky Survey Commissioning Data, M. Odenkirchen et al., *Astrophysical Journal Lett.* 548, 165 (2001).
- A New Very Cool White Dwarf Discovered by the Sloan Digital Sky Survey, H. Harris et al., *Astrophysical Journal Lett.* 549, 109 (2001).
- Stellar Population Studies with the SDSS I. The Vertical Distribution of Stars in the Milky Way, B. Chen et al., *Astrophysical Journal* 553, 184 (2001).
- Weak-Lensing Measurements of 42 SDSS/RASS Galaxy Clusters, E. Sheldon et al., *Astrophysical Journal* 554, 881 (2001).
- High-Redshift Quasars Found in Sloan Digital Sky Survey Commissioning Data VI. Sloan Digital Sky Survey Spectrograph Observations, S. Anderson, *Astronomical Journal* 122, 503 (2001).
- Composite Quasar Spectra from the Sloan Digital Sky Survey, D. Vanden Berk et al., *Astronomical Journal* 122, 549 (2001).
- Statistical Properties of Bright Galaxies in the SDSS Photometric System, K. Shimasaku et al., *Astronomical Journal* 122, 1238 (2001).
- Galaxy Number Counts from the Sloan Digital Sky Survey Commissioning Data, N. Yasuda et al., *Astronomical Journal* 122, 1104 (2001).
- Photometric Redshifts from Reconstructed Quasar Templates, T. Budavari et al., *Astronomical Journal* 122, 1163, (2001).
- Photometric Redshifts of Quasars, G. Richards et al., *Astronomical Journal* 122, 1151 (2001).
- Spectroscopic Target Selection for the Sloan Digital Sky Survey: The Luminous Red Galaxy Sample, D. Eisenstein et al., *Astronomical Journal* 122, 2267 (2001).
- A Photometricity and Extinction Monitor at the Apache Point Observatory, D. Hogg et al., *Astronomical Journal* 122, 2129 (2001).
- New Insights on the Draco Dwarf Spheroidal Galaxy from SDSS: a Larger Radius and No Tidal Tails, M. Odenkirchen et al., *Astronomical Journal* 122, 2538 (2001).
- Evidence for Reionization at $z \sim 6$: Detection of a Gunn-Peterson Trough in a $z=6.28$ Quasar, R. Becker et al., *Astronomical Journal* 122, 2850 (2001).
- A Survey of $z > 5.8$ Quasars in the Sloan Digital Sky Survey I: Discovery of Three New Quasars and the Spatial Density of Luminous Quasars at $z \sim 6$, X. Fan et al., *Astronomical Journal* 122, 2833 (2001).
- Color Separation of Galaxy Types in the Sloan Digital Sky Survey Imaging Data, I. Strateva et al., *Astronomical Journal* 122, 1861 (2001).
- Solar System Objects Observed in the SDSS Commissioning Data, Z. Ivezić et al., *Astronomical Journal* 122, 2749 (2001).
- Sloan Digital Sky Survey Multicolor Observations of GRB010222, B. Lee et al., *Astrophysical Journal* 561, 183 (2001).
- Broad Absorption Line Quasars in the Sloan Digital Sky Survey with VLA-FIRST Radio Detections, K. Menou et al., *Astrophysical Journal* 561, 645 (2001).
- Spectroscopic Target Selection in the Sloan Digital Sky Survey: The Main Galaxy Sample, M. Strauss et al., *Astronomical Journal* 124, 1810 (2002).
- Spectroscopic Target Selection in the Sloan Digital Sky Survey: The Quasar Sample, G. Richards et al., *Astronomical Journal* 123, 2945 (2002).
- The u'g'r'i'z' Standard Star Network, J. Smith et al., *Astronomical Journal* 123, 2121 (2002).

- Sloan Digital Sky Survey: Early Data Release, C. Stoughton et al., *Astronomical Journal* 123, 485 (2002).
- Color Confirmation of Asteroid Families, Z. Ivezić et al., *Astronomical Journal* 124, 2943 (2002).
- The Redshift of the Lensing Galaxy in PMN J0134-0931, P. Hall et al., *Astrophysical Journal Lett.* 575, L51, (2002).
- Kinematic Study of the Disrupting Globular Cluster Palomar 5 using VLT Spectra, M. Odenkirchen et al., *Astronomical Journal* 124, 1497 (2002).
- Cosmological Information from Quasar-Galaxy Correlations Induced by Weak Lensing, B. Menard et al., *Astronomy & Astrophysics* 386, 784 (2002).
- Faint High Latitude Carbon Stars Discovered by the Sloan Digital Sky Survey: Methods and Initial Results, B. Margon et al., *Astronomical Journal* 124, 1651 (2002).
- Composite Luminosity Functions of the Sloan Digital Sky Survey Cut and Enhance Galaxy Cluster Catalog, T. Goto et al., *Publ. Astronomical Society of the Pacific* 54, 515 (2002).
- The Luminosity Density of Red Galaxies, D. Hogg et al., *Astronomical Journal* 124, 646 (2002).
- Exploratory Chandra Observations of the Three Highest Redshift Quasars, W. Brandt et al., *Astrophysical Journal* 569, 5 (2002).
- Optical and Radio Properties of Extragalactic Sources Observed by the FIRST Survey and the SDSS, Z. Ivezić et al., *Astronomical Journal* 124, 2364 (2002).
- Comparison of Positions and Magnitudes of Asteroids Observed in the Sloan Digital Sky Survey with those Predicted for Known Asteroids, M. Juric et al., *Astronomical Journal* 124, 1776 (2002).
- Characterization of M, L and T Dwarfs in Sloan Digital Sky Survey, S. Hawley et al., *Astronomical Journal* 123, 3409 (2002).
- LOTIS, Super-LOTIS, SDSS and Tautenburg Observations of GRB010921, H. Park et al., *Astrophysical Journal Lett.* 571, 131 (2002).
- VLT Optical and Near-IR Observations of the $z=6.28$ Quasar 1030+0524, L. Pentericci et al., *Astronomical Journal* 123, 2151 (2002).
- Unusual Broad Absorption Line Quasars from the Sloan Digital Sky Survey, P. Hall et al., *Astrophysical Journal Suppl.* 141, 267 (2002).
- Dynamical Confirmation of SDSS Weak Lensing Scaling Laws, T. McKay et al., *Astrophysical Journal Lett.* 571, 85 (2002).
- SDSS J124602.54+011318.8: A Highly Luminous Optical Transient at a Redshift of 0.385, D. Vanden Berk et al., *Astrophysical Journal* 576, 673 (2002).
- Higher Order Moments of the Angular Distribution of Galaxies, I. Szapudi et al., *Astrophysical Journal* 570, 75 (2002).
- An SDSS Survey for Resolved Milky Way Satellite Galaxies I: Detection Limits, B. Willman et al., *Astronomical Journal* 123, 848 (2002).
- The Sloan Digital Sky Survey Quasar Catalog I. Early Data Release, D. Schneider et al., *Astronomical Journal* 123, 567 (2002).
- The Angular Clustering of Galaxy Pairs, L. Infante et al., *Astrophysical Journal* 567, 155 (2002).
- L Dwarfs Found in Sloan Digital Sky Survey Commissioning Data II. Hobby-Eberly Telescope Observations, D. Schneider et al., *Astronomical Journal* 123, 458 (2002).
- The Ghost of Sagittarius and Lumps in the Halo of the Milky Way, H. Newberg et al., *Astrophysical Journal* 569, 245 (2002).
- The Cut & Enhance Method: Selecting Clusters of Galaxies from the SDSS Commissioning Data, T. Goto et al., *Astronomical Journal* 123, 1807 (2002).

- Towards Spectral Classification of L and T Dwarfs: Infrared and Optical Spectroscopy and Analysis, T. Geballe et al., *Astrophysical Journal* 564, 466 (2002).
- Infrared Photometry of Late M, L, and T Dwarfs, S. Leggett et al., *Astrophysical Journal* 564, 452 (2002).
- The 3D Power Spectrum from Early SDSS Angular Clustering, S. Dodelson et al., *Astrophysical Journal* 572, 140 (2002).
- The Angular Power Spectrum of Galaxies from Early SDSS Data, M. Tegmark et al., *Astrophysical Journal* 571, 191 (2002).
- The Angular Correlation Function of Galaxies from Early SDSS Data, A. Connolly et al., *Astrophysical Journal* 579, 42 (2002).
- Analysis of Systematic Effects and Statistical Uncertainties in Angular Clustering of Galaxies from Early SDSS Data, R. Scranton et al., *Astrophysical Journal* 579, 48 (2002).
- Galaxy Clustering in Early SDSS Redshift Data, I. Zehavi et al., *Astrophysical Journal* 571, 172 (2002).
- Cataclysmic Variables from SDSS I. The First Results, P. Szkody et al., *Astronomical Journal* 123, 430 (2002).
- Detecting Clusters of Galaxies in the Sloan Digital Sky Survey I: Monte Carlo Comparison of Cluster Detection Algorithms, R. Kim et al., *Astronomical Journal* 123, 20 (2002).
- Three-Dimensional Genus Statistics of Galaxies in the SDSS Early Data Release, C. Hikage et al., *Publications Astronomical Society Japan* 54, 707 (2002).
- A Matched-Filter Analysis of the Tidal Tails Around the Globular Cluster Palomar 5, C. Rockosi et al., *Astronomical Journal* 124, 349 (2002).
- Two-Dimensional Topology of the Sloan Digital Sky Survey, F. Hoyle et al., *Astrophysical Journal* 580, 663 (2002).
- A Gravitationally Lensed Quasar with Quadruple Images Separated by 14.62 Arcseconds, N. Inada et al., *Nature* 426, 810 (2003).
- The Morphology-Density Relation in the Sloan Digital Sky Survey, T. Goto et al., *Monthly Notices Royal Astronomical Society* 346, 601 (2003).
- Sagittarius Tidal Debris 90 kpc from the Galactic Center, H. Newberg et al., *Astrophysical Journal Lett.* 596, 191 (2003).
- Continuum and Emission Line Properties of Broad Absorption Line Quasars, T. Reichard et al., *Astronomical Journal* 126, 2594 (2003).
- The Extended Tails of Palomar 5: A Ten Degree Arc of Globular Cluster Tidal Debris, M. Odenkirchen et al., *Astronomical Journal* 126, 2385 (2003).
- The Sloan Digital Sky Survey Quasar Catalog II. First Data Release, D.P. Schneider et al., *Astronomical Journal* 126, 2579 (2003).
- SDSS J0903+5028: A New Gravitational Lens, D. Johnston et al., *Astronomical Journal* 126, 2281 (2003).
- Discovery of Eight New Extremely Metal-Poor Galaxies in the Sloan Digital Sky Survey, A. Kniazev et al., *Astrophysical Journal Lett.* 593, 73 (2003).
- Magnetic White Dwarfs from the SDSS. The First Data Release, G. Schmidt et al., *Astrophysical Journal* 595, 1101 (2003).
- A Merged Catalog of Clusters of Galaxies from Early SDSS Data, N. Bahcall et al., *Astrophysical Journal Suppl.* 148, 243 (2003).
- Cataclysmic Variables from SDSS II. The Second Year, P. Szkody et al., *Astronomical Journal* 126, 1499 (2003).
- Investigating the SDSS Cataclysmic Variable SDSS J132723.39+652854.2, M. Wolfe et al., *Publications Astronomical Society Pacific* 115, 1118 (2003).

- A Large, Uniform Sample of X-ray Emitting AGNs: Selection Approach and an Initial Catalog from the ROSAT All-Sky and Sloan Digital Sky Surveys, S. Anderson et al., *Astronomical Journal* 126, 2209 (2003).
- An Initial Survey of White Dwarfs in the Sloan Digital Sky Survey, H. Harris et al., *Astronomical Journal* 126, 1023 (2003).
- Minkowski Functionals of SDSS Galaxies I: Analysis of Excursion Sets, C. Hikage et al., *Publications Astronomical Society Japan* 55, 911 (2003).
- Candidate Type II Quasars from the Sloan Digital Sky Survey: I. Selection and Optical Properties of a Sample at $0.3 < z < 0.83$, N. Zakamska et al., *Astronomical Journal* 126, 2125 (2003).
- Double-Peaked Low-Ionization Emission Lines in Active Galactic Nuclei, I. Strateva et al., *Astronomical Journal* 126, 1720 (2003).
- SDSS White Dwarfs with Spectra Showing Atomic Oxygen and/or Carbon Lines, J. Liebert et al., *Astronomical Journal* 126, 2521 (2003).
- The Environment of Passive Spiral Galaxies in the SDSS, T. Goto et al., *Publications Astronomical Society Japan* 55, 757 (2003).
- The Size Distribution of Galaxies in the Sloan Digital Sky Survey, S. Shen et al., *Monthly Notices Royal Astronomical Society* 343, 978 (2003).
- The Velocity Dispersion Function of Early-Type Galaxies, R. Sheth et al., *Astrophysical Journal* 594, 225 (2003).
- VLT+UVES Spectroscopy of the CaII LoBAL Quasar SDSS 0300+0048, P. Hall et al., *Astrophysical Journal* 593, 189 (2003).
- Observing the Dark Matter Density Profile of Isolated Galaxies, F. Prada et al., *Astrophysical Journal* 598, 260 (2003).
- A Low Latitude Halo Stream around the Milky Way, B. Yanny et al., *Astrophysical Journal* 588, 824 (2003).
- Angular Clustering with Photometric Redshifts in the Sloan Digital Sky Survey: Bimodality in the Clustering Properties of Galaxies, T. Budavari et al., *Astrophysical Journal* 595, 59 (2003).
- A Survey of $z > 5.7$ Quasars in the Sloan Digital Sky Survey II: Discovery of Three Additional Quasars at $z > 6$, X. Fan et al., *Astronomical Journal* 125, 1649 (2003).
- The Overdensities of Galaxy Environments as a Function of Luminosity and Color, D. Hogg et al., *Astrophysical Journal Lett.* 585, 5 (2003).
- The Sloan Digital Sky Survey: The Cosmic Spectrum and Star-Formation History, K. Glazebrook et al., *Astrophysical Journal* 587, 55 (2003).
- Hdelta-Selected Galaxies in the Sloan Digital Sky Survey I: The Catalog, T. Goto et al., *Publications Astronomical Society Japan* 55, 771 (2003).
- Red and Reddened Quasars in the Sloan Digital Sky Survey, G. Richards et al., *Astronomical Journal* 126, 1131 (2003).
- Determining the Lensing Fractions of SDSS Quasars: Methods and Results from the EDR, B. Pindor et al., *Astronomical Journal* 125, 2325 (2003).
- Average Spectra of Massive Galaxies in the SDSS, D. Eisenstein et al., *Astrophysical Journal* 585, 594 (2003).
- SDSS Catalog of Stars in the Draco Dwarf Spheroidal Galaxy, H. Rave et al., *Astrophysical Journal Suppl.* 145, 245 (2003).
- A Catalog of Broad Absorption Line Quasars from the Sloan Digital Sky Survey Early Data Release, T. Reichard et al., *Astronomical Journal* 125, 1711 (2003).
- Selection of Metal-Poor Giant Stars using the Sloan Digital Sky Survey Photometric System, A. Helmi et al., *Astrophysical Journal* 586, 195 (2003).

- The Galaxy Luminosity Function and Luminosity Density at Redshift $z < 0.1$, M. Blanton et al., *Astrophysical Journal* 592, 819 (2003).
- Luminosity Function of Morphologically Classified Galaxies in the SDSS Survey, O. Nakamura et al., *Astronomical Journal* 125, 1682 (2003).
- A First Look at White - M dwarf Pairs in SDSS, S. Raymond et al., *Astronomical Journal* 125, 2621 (2003).
- The Broadband Optical Properties of Galaxies with Redshifts $0.2 < z < 0.22$, M. Blanton et al., *Astrophysical Journal* 594, 186 (2003).
- The Application of Photometric Redshifts to the SDSS Early Data Release, I. Csabai et al., *Astronomical Journal* 125, 580 (2003).
- Galaxy Star-Formation as a Function of Environment in the Early Data Release of the Sloan Digital Sky Survey, P. Gomez et al., *Astrophysical Journal* 584, 210 (2003).
- Two Rare Magnetic Cataclysmic Variables with Extreme Cyclotron Features Identified in the Sloan Digital Sky Survey, P. Szkody et al., *Astrophysical Journal* 583, 902 (2003).
- The Cluster Mass Function from Early SDSS Data: Cosmological Implications, N. Bahcall et al., *Astrophysical Journal* 585, 182 (2003).
- SDSS J092455.87+021924.9: an Interesting Gravitationally Lensed Quasar from the Sloan Digital Sky Survey, N. Inada et al., *Astronomical Journal* 126, 666 (2003).
- A Feature at $z \sim 3.2$ in the Evolution of the Ly-alpha Forest Optical Depth, M. Bernardi et al., *Astronomical Journal* 125, 32 (2003).
- Estimating Fixed-Frame Galaxy Magnitudes in the SDSS, M. Blanton et al., *Astronomical Journal* 125, 2348 (2003).
- Early-type Galaxies in the SDSS IV: Colors and Chemical Evolution, M. Bernardi et al., *Astronomical Journal* 125, 1882 (2003).
- Early-type Galaxies in the SDSS III: The Fundamental Plane, M. Bernardi et al., *Astronomical Journal* 125, 1866 (2003).
- Early-type Galaxies in the SDSS II: Correlations Between Observables, M. Bernardi et al., *Astronomical Journal* 125, 1849 (2003).
- Early-type Galaxies in the SDSS I: The Sample, M. Bernardi et al., *Astronomical Journal* 125, 1817 (2003).
- The Environmental Dependence of Galaxy Properties in the Local Universe: Dependence on Luminosity, Local Density, and System Richness, M. Tanaka et al., *Astronomical Journal* 128, 2677 (2004).
- Spectral Classification of Quasars in the Sloan Digital Sky Survey: {Eigenspectra;} Redshift and Luminosity Effects, C. Yip et al., *Astronomical Journal* 128, 2603 (2004).
- Efficient Photometric Selection of Quasars from the Sloan Digital Sky Survey: 100000 $z < 3$ Quasars from Data Release One, G. Richards et al., *Astrophysical Journal Suppl.* 155, 257 (2004).
- Distributions of Galaxy Spectral Types in the Sloan Digital Sky Survey, C. Yip et al., *Astronomical Journal* 128, 585 (2004).
- Dust Reddening in SDSS Quasars, P. Hopkins et al., *Astronomical Journal* 128, 1112 (2004).
- An Empirical Algorithm for Broad-band Photometric Redshifts of Quasars from the Sloan Digital Sky Survey, M. Weinstein et al., *Astrophysical Journal Suppl.* 155, 243 (2004).
- Discovery of New Ultracool White Dwarfs in the Sloan Digital Sky Survey, E. Gates et al., *Astrophysical Journal Lett.* 612, 129 (2004).
- Cataclysmic Variables from SDSS III. The Third Year, P. Szkody et al., *Astronomical Journal* 128, 1882 (2004).

- A Survey of $z > 5.7$ Quasars in the Sloan Digital Sky Survey III: Discovery of Five Additional Quasars, X. Fan et al., *Astronomical Journal* 128, 515 (2004).
- Three-point Correlation Functions of SDSS Galaxies in Redshift Space: Morphology, Color and Luminosity Dependence, I. Kayo et al., *Publ. Astronomical Society Japan* 56, 415 (2004).
- ROSAT-SDSS Galaxy Clusters Survey. I. The Catalog and the Correlation of X-ray and Optical Properties, P. Popesso et al., *Astronomy and Astrophysics* 423, 449 (2004).
- Andromeda IX: A New Dwarf Spheroidal Satellite of M31, D. Zucker et al., *Astrophysical Journal Lett.* 612, 121 (2004).
- A Catalog of Spectroscopically Identified White Dwarf Stars in the First Data Release of the Sloan Digital Sky Survey, S. Kleinman et al., *Astrophysical Journal* 607, 426 (2004).
- Near-Infrared Photometry and Spectroscopy of L and T Dwarfs: the Effects of Temperature, Clouds, and Gravity, G. Knapp et al., *Astronomical Journal* 127, 3553 (2004).
- Microlensing of the Broad Emission Line Region in the Quadruple Lens SDSS J1004+4112, G. Richards et al., *Astrophysical Journal* 610, 679 (2004).
- Spectroscopic Properties of Cool Stars in the SDSS: An Analysis of Magnetic Activity and a Search for Subdwarfs, A. West et al., *Astronomical Journal* 128, 426 (2004).
- The Environmental Dependence of the Relations between Stellar Mass, Structure, Star Formation and Nuclear Activity in Galaxies, G. Kauffmann et al., *Mon. Not. Royal Astronomical Society* 347, 731 (2004).
- A New Giant Stellar Structure Near the Outer Halo of M31: Satellite or Stream?, D. Zucker et al., *Astrophysical Journal Lett.* 612, 117 (2004).
- Spatial Variations of Galaxy Number Counts in the SDSS I.: Extinction, Large-Scale Structure and Photometric Homogeneity, M. Fukugita et al., *Astronomical Journal* 127, 3155 (2004).
- The H α Luminosity Function of Morphologically Classified Galaxies in the Sloan Digital Sky Survey, O. Nakamura et al., *Astronomical Journal* 127, 2511 (2004).
- Observations and Theoretical Implications of the Large Separation Lensed Quasar SDSS J1004+4112, M. Oguri et al., *Astrophysical Journal* 605, 78 (2004).
- The Physical Properties of Star Forming Galaxies in the Low Redshift Universe, J. Brinchmann et al., *Mon. Not. Royal Astronomical Society* 351, 1151 (2004).
- The Galaxy-Mass Correlation Function Measured from Weak Lensing in the SDSS, E. Sheldon et al., *Astronomical Journal* 127, 2544 (2004).
- A Strategy for Finding Near Earth Objects with the SDSS Telescope, S. Raymond et al., *Astronomical Journal* 127, 2888 (2004).
- Cosmological Parameters from Eigenmode Analysis of Sloan Digital Sky Survey, A. Pope et al., *Astrophysical Journal* 607, 655 (2004).
- Faint High-Latitude Carbon Stars Discovered by the Sloan Digital Sky Survey: An Initial Catalog, R. Downes et al., *Astronomical Journal* 127, 2838 (2004).
- Cosmological Parameters from SDSS and WMAP, M. Tegmark et al., *Phys. Rev.* D69, 103501 (2004).
- SDSS J1335+118: A New Two-Image Gravitational Lens, M. Oguri et al., *Publ. Astronomical Society Japan* 56, 399 (2004).
- An Improved Proper Motion Catalog Combining USNO-B and SDSS, J. Munn et al., *Astronomical Journal* 127, 3034 (2004).
- L' and M' Photometry of Ultracool Dwarfs, D. Golimowski et al., *Astronomical Journal* 127, 3516 (2004).
- Blue Horizontal Branch Stars in the Sloan Digital Sky Survey: II. Kinematics of the Galactic Halo, E. Sirko et al., *Astronomical Journal* 127, 914 (2004).

- Blue Horizontal Branch Stars in the Sloan Digital Sky Survey: I. Sample Selection and Structure in the Galactic Halo, E. Sirko et al., *Astronomical Journal* 127, 899 (2004).
- Detection of Intergalactic HeII Absorption at Redshift 3.5, W. Zheng et al., *Astronomical Journal* 127, 656 (2004).
- SDSS J15517.35+6346220.0: A Newly Discovered Gravitationally Lensed Quasar, B. Pindor et al., *Astronomical Journal* 127, 1318 (2004).
- VLT + UVES Spectroscopy of the Low-Ionization Intrinsic Absorber in SDSS J001130.56+005550.7, D. Hutsemekers et al., *Astronomy and Astrophysics* 415, 77 (2004).
- Sloan Digital Sky Survey Spectroscopic Lens Search: I. Discovery of Intermediate-Redshift Star-Forming Galaxies Behind Foreground Luminous Red Galaxies, A. Bolton et al., *Astronomical Journal* 127, 1860 (2004).
- The Ensemble Photometric Variability of ~2500 Quasars in the Sloan Digital Sky Survey, D. Vanden Berk et al., *Astrophysical Journal* 601, 692 (2003).
- A Snapshot Survey for Gravitational Lenses Among $z \geq 4.0$ Quasars: I. The $z > 5.7$ Sample, G. Richards et al., *Astronomical Journal* 127, 1305 (2004).
- Halos Around the Edge-On Disk Galaxies in the SDSS, S. Zibetti et al., *Mon. Not. Royal Astronomical Society* 347, 556 (2004).
- The Dependence on Environment of the Color-Magnitude Relation of Galaxies, D. Hogg et al., *Astrophysical Journal Lett.* 601, 29 (2004).
- Stellar and Dynamical Masses of Ellipticals in the Sloan Digital Sky Survey, N. Padmanabhan et al., *New Astronomy* 9(5), 329 (2004).
- The Three-Dimensional Power Spectrum of Galaxies from the Sloan Digital Sky Survey, M. Tegmark et al., *Astrophysical Journal* 606, 702 (2004).
- Star Formation Rate Indicators in the Sloan Digital Sky Survey, A. Hopkins et al., *Astrophysical Journal* 599, 971 (2003).
- Quantifying the Bimodal Color-Magnitude Distribution of Galaxies, I. Baldry et al., *Astrophysical Journal* 600, 681 (2004).
- The Host Galaxies of AGN, G. Kauffmann et al., *Mon. Not. Royal Astronomical Society* 346, 1055 (2003).
- Galaxy Types in the Sloan Digital Sky Survey Using Supervised Artificial Neural Networks, N. Ball et al., *Mon. Not. Royal Astronomical Society* 348(3), L1038 (2004).
- Selection and Photometric Properties of K+A Galaxies, A. Quintero et al., *Astrophysical Journal* 602, 109 (2004).
- On Departures from a Power Law in the Galaxy Correlation Function, I. Zehavi et al., *Astrophysical Journal* 608, 16 (2004).
- The Near-IR Properties and Continuum Shape of High Redshift Quasars from the Sloan Digital Sky Survey, L. Pentericci et al., *Astronomy and Astrophysics* 410, 75 (2003).
- The Dependence of Star Formation History and Internal Structure on Stellar Mass for 80,000 Low Redshift Galaxies, G. Kauffmann et al., *Mon. Not. Royal Astronomical Society* 341, 54 (2003).
- Stellar Masses and Star Formation Histories for 80,000 Galaxies from the Sloan Digital Sky Survey, G. Kauffmann et al., *Mon. Not. Royal Astronomical Society* 341, 33 (2003).
- Sloan Digital Sky Survey Imaging of Low Galactic Latitude Fields: Technical Summary and Data Release, D. Finkbeiner et al., *Astronomical Journal* 128, 2577 (2004).
- The Second Data Release of the Sloan Digital Sky Survey, K. Abazajian et al., *Astronomical Journal* 128, 502 (2004).
- SDSS Data Management and Photometric Quality Assessment, Z. Ivezić et al., *Astronomische Nachrichten* 325, 583 (2004).

- Ultracompact AM CVn Binaries from the Sloan Digital Sky Survey: Three Candidates Plus the First Confirmed Eclipsing System, S. Anderson et al., *Astronomical Journal* 130, 2236 (2005).
- SDSS J0246-0825: A New Gravitationally Lensed Quasar from the Sloan Digital Sky Survey, N. Inada et al., *Astronomical Journal* 130, 1967 (2005).
- Photometric Accretion Signatures Near the Substellar Boundary, P. McGehee et al., *Astronomical Journal* 130, 1752 (2005).
- The SDSS View of the Palomar-Green Bright Quasar Survey, S. Jester et al., *Astronomical Journal* 130, 873 (2005).
- New Low Accretion-Rate Magnetic Binary Systems and Their Significance for the Evolution of Cataclysmic Variables G., D. Schmidt et al., *Astrophysical Journal* 630, 1037 (2005).
- Magnetic White Dwarfs from the SDSS II. The Second and Third Data Releases, K. Vanlandingham et al., *Astronomical Journal* 130, 734 (2005).
- Dark Matter and Stellar Mass in the Luminous Regions of Disk Galaxies, J. Pizagno et al., *Astrophysical Journal* 633, 844 (2005).
- Eleven New DAVs from the Sloan Survey, F. Mullally et al., *Astrophysical Journal* 625, 966 (2005).
- The Color Selection of Quasars from Redshifts 5 to 10: Cloning and Discovery, K. Chiu et al., *Astronomical Journal* 130, 13 (2005).
- Detection of Cosmic Magnification with the Sloan Digital Sky Survey, R. Scranton et al., *Astrophysical Journal* 633, 589 (2005).
- Spectral Variability of Quasars in the Sloan Digital Sky Survey. I: Wavelength Dependence, B. Wilhite et al., *Astrophysical Journal* 633, 638 (2005).
- Detection of the Baryon Acoustic Peak in the Large-Scale Correlation Function of SDSS Luminous Red Galaxies, D. Eisenstein et al., *Astrophysical Journal* 633, 560 (2005).
- The Nature of Nearby Counterparts to Intermediate Redshift Luminous Compact Blue Galaxies. II CO Observations, C. Garland et al., *Astrophysical Journal* 624, 714 (2005).
- Cataclysmic Variables from SDSS IV. 2003 Year, P. Szkody et al., *Astronomical Journal* 129, 2386 (2005).
- Systematic Errors in Weak Lensing: Application to SDSS Galaxy-Galaxy Weak Lensing, R. Mandelbaum et al., *Mon. Not. Royal Astronomical Society* 361, 1287 (2005).
- SDSS ~J210014.12+004446.0: A New Dwarf Nova with Quiescent Superhumps?, J. Trampusch et al., *Publ. Astronomical Society Pacific* 117, 262 (2005).
- The SDSS u-band Galaxy Survey: Luminosity Functions and Evolution, I. Baldry et al., *Mon. Not. Royal Astronomical Society* 358, 441 (2005).
- Active Galactic Nuclei in the Sloan Digital Sky Survey: II. Emission-Line Luminosity Function, L. Hao et al., *Astronomical Journal* 129, 1795 (2005).
- Active Galactic Nuclei in the Sloan Digital Sky Survey: I. Sample Selection, L. Hao et al., *Astronomical Journal* 129, 1783 (2005).
- Large Scale Clustering of Sloan Digital Sky Survey Quasars: Impact of the Baryon Density and the Cosmological Constant, K. Yahata et al., *Publ. Astronomical Society Japan* 57, 529 (2005).
- An Empirical Calibration of the Completeness of the SDSS Quasar Survey, D. Vanden Berk et al., *Astronomical Journal* 129, 2047 (2005).
- The Sloan Digital Sky Survey Quasar Catalog III. Third Data Release, D. Schneider et al., *Astronomical Journal* 130, 367 (2005).
- Intergalactic Stars in $z \sim 0.25$ Galaxy Clusters: Systematic Properties from Stacking of Sloan Digital Sky Survey Imaging Data, S. Zibetti et al., *Mon. Not. Royal Astronomical Society* 358, 949 (2005).

- The RASS-SDSS Galaxy Cluster Survey. III Scaling Relations of Galaxy Clusters, P. Popesso et al., *Astronomy and Astrophysics* **433**, 431 (2005).
- The Intermediate-Scale Clustering of Luminous Red Galaxies, I. Zehavi et al., *Astrophysical Journal* **621**, 22 (2005).
- The Small-Scale Clustering of Luminous Red Galaxies Via Cross-Correlation Techniques, D. Eisenstein et al., *Astrophysical Journal* **619**, 178 (2005).
- Cosmic Homogeneity Demonstrated with Luminous Red Galaxies, D. Hogg et al., *Astrophysical Journal* **624**, 54 (2005).
- XMM-Newton and Optical Follow-up Observations of Three New Polars from the Sloan Digital Sky Survey, L. Homer et al., *Astrophysical Journal* **620**, 929 (2005).
- A Comprehensive Model for the Monoceros Tidal Stream, J. Penarrubia et al., *Astrophysical Journal* **626**, 128 (2005).
- Colors, Magnitudes and Velocity Dispersions in Early-Type Galaxies: Implications for Galaxy Ages and Metallicities, M. Bernardi et al., *Astronomical Journal* **129**, 61 (2005).
- The Nature of Nearby Counterparts to Intermediate Redshift Luminous Compact Blue Galaxies I. Optical/H I Properties and Dynamical Masses, C. Garland et al., *Astrophysical Journal* **615**, 689 (2004).
- A New Milky Way Companion: Unusual Globular Cluster or Extreme Dwarf Satellite?, B. Willman et al., *Astronomical Journal* **129**, 2692 (2005).
- Candidate Type II Quasars from the SDSS: III. Spectropolarimetry Reveals Hidden Type I Nuclei, N. Zakamska et al., *Astronomical Journal* **129**, 1212 (2005).
- XMM-Newton Observations of the Extremely Low Accretion Rate Polars SDSSJ155331.12 + 551614.5 and SDSSJ132411.57 + 032050.5, P. Szkody et al., *Astronomical Journal* **128**, 2443 (2004).
- Discovery of Two Gravitationally Lensed Quasars with Image Separations of 3 Arcseconds from the Sloan Digital Sky Survey, M. Oguri et al., *Astrophysical Journal* **622**, 106 (2005).
- NYU-VAGC: A Galaxy Catalog Based on New Public Surveys, M. Blanton et al., *Astronomical Journal* **129**, 2562 (2005).
- Optically Identified BL Lacertae Objects from the Sloan Digital Sky Survey, M. Collinge et al., *Astronomical Journal* **129**, 2542 (2005).
- The Properties and Luminosity Function of Extremely Low Luminosity Field Galaxies, M. Blanton et al., *Astrophysical Journal* **631**, 208 (2005).
- Spectroscopic Properties of Void Galaxies in the Sloan Digital Sky Survey, R. Rojas et al., *Astrophysical Journal* **624**, 571 (2005).
- RASS-SDSS Galaxy Clusters Survey.II. A Unified Picture of the Cluster Luminosity Function, P. Popesso et al., *Astronomy and Astrophysics* **433**, 415 (2005).
- The Luminosity and Color Dependence of the Galaxy Correlation Function, I. Zehavi et al., *Astrophysical Journal* **63**, 1 (2005).
- Cosmological Parameter Analysis Including SDSS Ly-Alpha Forest and Galaxy Bias: Constraints on the Primordial Spectrum of Fluctuations, Neutrino Mass, and Dark Energy, U. Seljak et al., *Phys. Rev.* **D71**, 103515 (2005).
- Calibrating Photometric Redshifts of Luminous Red Galaxies, N. Padmanabhan et al., *Mon. Not. Royal Astronomical Society* **359**, 237 (2005).
- Cosmology and the Halo Occupation Distribution from Small-Scale Galaxy Clustering in the Sloan Digital Sky Survey, K. Abazajian et al., *Astrophysical Journal* **625**, 613 (2005).
- Distributions of Galaxy Spectral Types in the Sloan Digital Sky Survey, C. Yip et al., *Astronomical Journal* **128**, 585 (2004).

SDSS Galaxy Bias Determination from Halo Mass-Bias Relation and Its Cosmological Implications, U. Seljak et al., *Phys. Rev.* D71, 043511 (2005).

Cross-Correlation of CMB with Large-Scale Structure: Weak Gravitational Lensing, C. Hirata et al., *Phys. Rev.* D70, 103501 (2004).

Galaxy-Galaxy Weak Lensing in SDSS: Intrinsic Alignments and Shear Calibration Errors, C. Hirata et al., *Mon. Not. Royal Astronomical Society* 353, 529 (2004).

A Gravitationally Lensed Quasar with Quadruple Images Separated by 14.62 Arcseconds, N. Inada et al., *Nature* 426, 810 (2003).

The Luminosity Function of Void Galaxies in the Sloan Digital Sky Survey, F. Hoyle et al., *Astrophysical Journal* 620, 618 (2005).

A Map of the Universe, J. R. Gott et al., *Astrophysical Journal* 624, 463 (2005).

A Lyman-Alpha-Only AGN from the Sloan Digital Sky Survey, P. Hall et al., *Astronomical Journal* 127, 3146 (2004).

The Morphology-Density Relation in the Sloan Digital Sky Survey, T. Goto et al., *Mon. Not. Royal Astronomical Society* 346, 601 (2003).

Relationship Between Environment and the Broad-Band Optical Properties of Galaxies in the SDSS, M. Blanton et al., *Astrophysical Journal* 629, 143 (2005).

The Third Data Release of the Sloan Digital Sky Survey, K. Abazajian et al., *Astronomical Journal* 129, 1755 (2004).

A Spectroscopic Survey of Faint Quasars in the SDSS Deep Stripe: I. Preliminary Results from the Co-added Catalog, L. Jiang et al., *Astronomical Journal* 131, 2788 (2006).

Average Extinction Curves and Relative Abundances for QSO Absorption Line Systems at $1 \leq z_{\text{abs}} < 2$, D. York et al., *Mon. Not. Royal Astronomical Society* 367, 945 (2006).

SDSSJ103913.70+533029.5: A Super Star Cluster in the Outskirts of a Galaxy Merger G., R. Knapp et al., *Astronomical Journal* 131, 859 (2006).

SDSS J0806+2-6 and SDSS J1353+1138: Two New Gravitationally Lensed Quasars from the Sloan Digital Sky Survey, N. Inada et al., *Astronomical Journal* 131, 1934 (2006).

A Survey of $z > 5.7$ Quasars in the Sloan Digital Sky Survey IV: Discovery of Seven Additional Quasars, X. Fan et al., *Astronomical Journal* 131, 1203 (2006).

Cataclysmic Variables from the Sloan Digital Sky Survey: V the Fifth Year (2004), P. Szkody et al., *Astrophysical Journal* 131, 973 (2006).

Spectral Variability of Quasars in the Sloan Digital Sky Survey. II: The CIV Line, B. Wilhite et al., *Astrophysical Journal* 641, 78 (2006).

First Measurement of the Clustering Evolution of Photometrically Classified Quasars, A. Myers et al., *Astrophysical Journal* 638, 622 (2006).

Candidate Isolated Neutron Stars and Other Optically Blank X-ray Fields Identified from the ROSAT All-Sky and Sloan Digital Sky Surveys, M. Agueros et al., *Astronomical Journal* 131, 1740 (2006).

Galaxy Halo Masses and Satellite Fractions from Galaxy-Galaxy Lensing in the SDSS: Stellar Mass, Luminosity, Morphology, and Environment Dependencies, R. Mandelbaum et al., *Mon. Not. Royal Astronomical Society* 367, 611 (2006).

The White Dwarf Luminosity Function from SDSS Imaging Data, H. Harris et al., *Astronomical Journal* 131, 571 (2006).

The Bright End of the Luminosity Function of Red Sequence Galaxies, Y. Loh et al., *Mon. Not. Royal Astronomical Society* 366, 373 (2006).

Gas Infall and Stochastic Star Formation in Galaxies in the Local Universes, G. Kauffmann et al., *Mon. Not. Royal Astronomical Society* 367, 1394 (2006).

- Chandra and XMM Observations of Type II Quasars from the SDSS, A. Ptak et al., *Astrophysical Journal* 637, 147 (2006).
- Spectral Decomposition of Broad-Line AGNs and Host Galaxies, D. Vanden Berk et al., *Astronomical Journal* 131, 84 (2006).
- A Snapshot Survey for Gravitational Lenses Among $z \geq 4.0$ Quasars: II. The $4.0 < z < 5.4$ Sample, G. Richards et al., *Astronomical Journal* 131, 49 (2006).
- Evolution and Environment of Early-Type Galaxies, M. Bernardi et al., *Astronomical Journal* 131, 1288 (2006).
- SDSSJ102111.02+491330.4: A Newly Discovered Gravitational Lensed Quasar, B. Pindor et al., *Astronomical Journal* 131, 41 (2006).
- A Catalog of Spectroscopically Selected Close Binary Systems from the Sloan Digital Sky Survey Data Release Four, N. Silvestri et al., *Astronomical Journal* 131, 1674 (2006).
- Fourier Phase Analysis of SDSS Galaxies, C. Hikage et al., *Publ. Astronomical Society Japan* 57, 709 (2005).
- Characteristic QSO Accretion Disk Temperatures from Spectroscopic Continuum Variability, N. Pereyra et al., *Astrophysical Journal* 642, 87 (2006).
- Topology Analysis of the Sloan Digital Sky Survey: I. Scale and Luminosity Dependences, C. Park et al., *Astrophysical Journal* 633, 11 (2005).
- Binary Quasars in the Sloan Digital Sky Survey: Evidence for Excess Clustering on Small Scales, J. Hennawi et al., *Astronomical Journal* 131, 1 (2006).
- The Linear Theory Power Spectrum from the Lyman-alpha Forest in the Sloan Digital Sky Survey, P. McDonald et al., *Astrophysical Journal* 635, 761 (2005).
- Correlating the CMB with Luminous Red Galaxies: The Integrated Sachs-Wolfe Effect, N. Padmanabhan et al., *Phys. Rev. D* 72, 043525 (2005).
- The Lyman-Alpha Forest Power Spectrum from the Sloan Digital Sky Survey, P. McDonald et al., *Astrophysical Journal Suppl.* 163, 80 (2006).

E-886

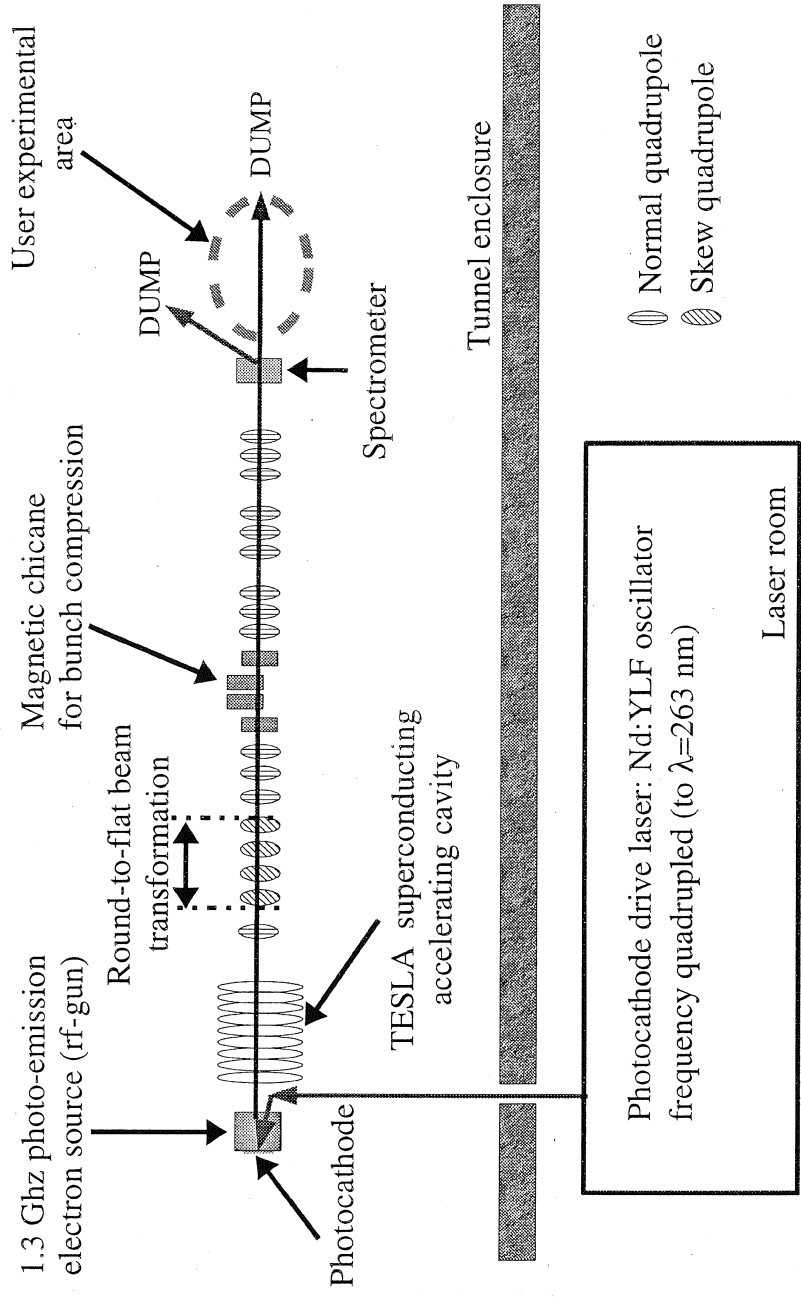

E-886 (Edwards / Filler) Advanced Accelerator Physics Experiments at the Fermilab A0 Photoinjector Laboratory (FA0PL)

ANL, Cornell, Fermilab, Illinois, Oxford, Rutgers

Status: *Data-Taking*

The Fermilab A0 Photoinjector Laboratory (FA0PL), operated by Fermilab, is available for experiments by any interested group. Proposals for new experiments are evaluated by the FA0PL Advisory Committee chaired by K.-J. Kim of the University of Chicago (see <http://nicadd.niu.edu/fnpl> for details).

Existing Equipment and Capabilities

The FA0PL consists of a 1½ cell L-band rf-gun equipped with a high quantum efficiency Cesium-Telluride photocathode, allowing the photoemission of electron bunches with charge up to approximately 15 nC. The generated bunches are further accelerated, up to 16 MeV, by a downstream TESLA-type superconducting accelerating cavity operating with a nominal accelerating gradient of approximately 12 MV/m. Downstream of the TESLA cavity, the beamline includes a set of quadrupoles and steering dipole elements for beam focusing and orbit correction, a skew quadrupole channel that allows the generation of flat beam using an incoming angular-momentum-dominated beam. The beamline also incorporates a magnetic bunch compressor chicane which can enhance the bunch peak current up to approximately 2.5 kA. The diagnostics for measuring transverse beam properties consist of electromagnetic beam position monitors, optical transition radiation screens (for measuring beam transverse density) and three emittance measurement stations based on the multi-slit mask technique. The bunch length measurement is performed by a streak camera that streaks optical transition radiation pulses emitted by the bunch. An alternative frequency-domain bunch length diagnostic based on Martin-Puplett interferometer of coherent transition radiation is also available. Downstream of the beamline, the beam can be bent in a dispersive section, to measure the beam energy distribution, or transported in a straight-ahead user experimental area.

The FA0PL facility can be operated remotely and to date teams from LBNL and DESY have used this capability to remotely perform beam physics experiments.

Research activities for 2006

Theory and simulations:

Modeling and numerical studies have primarily focused on the beam dynamics associated with transverse to longitudinal emittance exchange. A new beamline consisting of a dogleg, deflecting mode RF cavity, a second dogleg, and a short diagnostic section is being planned to demonstrate transverse to

longitudinal emittance exchange. Modeling efforts are focusing on the necessary optical qualities of the beamline and understanding the beam properties after the exchange.

Other modeling activities have focused on secondary and field electron emission inside of an RF gun. These studies were concerned with identifying the problems posed to the photocathode in the gun from any bombarding electrons. It is also important to understand our time dependant quantum efficiency. Secondary emission simulations have allowed us to start characterize the secondary emission when it was compared to measurements.

Experimental activities:

Experimental and operational activities include:

- Continued effort toward understanding and optimizing beam emittance and other properties
- Implementation of the transverse to longitudinal emittance exchange experiment
- Construction of a copper deflecting mode cavity for this experiment
- Implementation of an Interference Optical Transition Radiation (IOTR) experiment
- Work on a GaAs photocathode preparation chamber as part of research toward a polarized electron beam RF gun
- Support of a Cornell and UIUC team doing research on ILC fast kicker design
- Collaboration with Argonne National Laboratory on electro-optical sampling bunch length diagnostic development
- Use of the photoinjector RF cavities for low level RF development
- Improvements to the photocathode drive laser and pulse stacker
- Improvements to the control system with an integrated DOOCS system from DESY

Much effort was spent understanding and optimizing our transverse emittance. Continuing from previous measurements, we measured the transverse emittance as a function of charge and solenoid currents. This allowed us to reach an optimum of 4 mm-mrad normalized rms emittance with a 2.2 ps laser pulse. Subsequent measurements were done using a 20 ps flattop laser pulse. The ability to accurately measure the transverse emittance using screens at different locations along the beamline was considered. Initial results show that the effects of space charge may make this method less desirable than the standard multi-slit method currently used.

Construction has begun on a copper 5 cell 3.9 GHz deflecting mode cavity for the emittance exchange experiment mentioned above. The cavity is based in the profile used for a 13 cell 3.9 GHz superconducting deflecting mode cavity. Work also started on designing and purchasing the necessary parts to install an emittance exchange line in the spring of 2007.

An experiment aiming to measure the beam divergence and/or energy spread using the optical transition radiation (IOTR) interference technique has been installed and initial data is being taken. In this experiment, the interference pattern of the OTR radiation produced by two thin mica foils separated by ~1 mm is analyzed to infer the electron beam parameters.

In parallel with the FA0PL experimental program, work progressed on building a chamber to produce NEA GaAs photocathodes to make spin polarized electron beams. Experiments using liquid nitrogen cooling in an RF gun were concluded with unfavorable results. It was found that cooling in such a way produces a lower pressure, higher density gas than exists during room temperature operation of the gun. Other avenues of producing high-quality vacuum (10^{-11} torr) in a gun are being pursued with in collaboration with BNL and DULY Research Inc.

A team from Cornell and UIUC installed a new high voltage pulser to drive a kicker that was previously installed. The pulse was designed to produce the pulse train needed to drive an ILC damping ring kicker. Initial tests on the pulse revealed some design flaws and produced enough data to evaluate the feasibility of using this type of pulser.

A collaboration was formed with a group at Argonne National Laboratory to use electro-optical sampling (EOS) to measure the bunch length of sub-millimeter-length electron bunches. Bench tests at the Argonne Wakefield Accelerator laser laboratory using optical rectification of a seed pulse will characterize the crystals. Electron beam tests will follow at Argonne.

Low-level RF (LLRF) controls system testing continued. Comparisons between systems used at DESY and the SNS were done. Work was done at FA0PL to increase our local expertise with the DESY SimCon 3.1 system to use it in other facilities to be constructed on site.

Further improvements to the photocathode drive laser continue. The multi-pass flashlamp pumped amplifier is the cause of energy fluctuations. A new diode pumped system is being implemented and commissioned. Timing jitter between the laser and bunch length diagnostic has been improved. In addition, it was found that the pulse stacker was not producing the appropriate flat top pulses. Some incorrect optical elements were found and replaced.

The DOOCS system from DESY was also install at FA0PL. This provided us with a unified interface to control the entire accelerator instead of relying on multiple interfaces for various tasks. The initial installation has been completed. Now work on debugging the system and improving the interface to meet our needs is continuing.

Publications

Electro-Optic Measurement of the Wake Fields of a Relativistic Electron Beam, M. J. Fitch et al., Phys. Rev. Lett. 87, 034801 (2001).

Etude Experimentale du Photo-injecteur de Fermilab, J. P. Carneiro, Ph.D. Thesis, Universite Paris XI (fnalpubs.fnal.gov/cgi-bin/theses.pl), 2001.

Electro-Optic Sampling of Transient Electric Fields from Charged Particle Beams, M. J. Fitch, Ph.D. Thesis, University of Rochester (fnalpubs.fnal.gov/cgi-bin/theses.pl), 2001.

Angular Momentum Measurement of the FNPL Electron Beam, Y.-E. Sun, et al., presented at PAC 2003, Portland, OR.

Emittance Compensation Studies of Photoinjector Beams with Angular Momentum, S. Lidia, presented at PAC 2003, Portland, OR.

Notes on Sub-Picosecond Bunch Length Measurement at Fermilab A0/NICADD Photoinjector, D Mihalcea, preprint NICADD-0010 (2003).

Recent Improvements in the ASTRA Tracking Code, K. Flöttmann, et al., presented at PAC 2003, Portland, OR.

The UCLA/NICADD Plasma Density Transition Trapping Experiment, M. Thompson et al, presented at PAC 2003, Portland, OR.

Generation of Angular-Momentum-Dominated Electron Beam from a Photo-injector, Y.-E Sun et al., Phys. Rev. Spec. Topics-Accelerators and Beams 7, 123501-1 (2004).

Limiting Effects in the Round-to-Flat Beam Transformation, Y.-E Sun et al., 22nd Int'l Linear Accel. Conf. (LINAC 2004), Lubeck, Germany, August 2004. Fermilab-Conf-04-212-AD.

Progress Report on the Flat Beam Experiment at Fermilab/NICADD Photoinjector Laboratory, Y.-E Sun et al., 22nd Int'l Linear Accel. Conf. (LINAC 2004), Lubeck, Germany, August 2004. Fermilab-Conf-04-192-AD.

Investigation of the Longitudinal Beam Dynamics in a Photoinjector Using a Two-Macroparticle Model, R. Tikhoplav et al., 22nd Int'l Linear Accel. Conf. (LINAC 2004), Lubeck, Germany, August 2004. Fermilab-Conf-04-191-AD.

Status of the UCLA/NICADD Plasma Density Transition Trapping Experiment, M. C. Thompson et al., Proc. 11th Advanced Accel. Concept Workshop (AAC 2004), Stony Brook, NY, June 2004. AIP Conf. Proceeding 737, 440 (2004)

On Using NEA Cathodes in an RF Gun, M. Huening, 9th European Particle Accelerator Conference (EPAC 2004), Lucerne, Switzerland, July 2004.

Energy Loss of a High-Charge Bunched Electron Beam in Plasma: Analysis, N. Barov et al., Phys. Rev. Spec. Topics-Accelerators and Beams 7, 061301-1 (2004).

Angular-Momentum-Dominated and Flat-Beam Generation Y.-E Sun, Ph.D. Thesis, University of Chicago (Fermilab-Thesis No. 2005-17 fnalpubs.fnal.gov/cgi-bin/theses.pl) (2005).

The UCLA/FNPL Time Resolved Underdense Plasma Lens Experiment, M.C. Thompson, et al. Proc. 2005 PAC, Knoxville TN, 3003 (2005).

Time Dependent Quantum Efficiency and Dark Current Measurements in an RF Photocathode Injector with a High Quantum Efficiency Cathode, R.P. Fliller, H. Edwards, and W. Hartung, Proc. 2005 PAC, Knoxville TN, 2681 (2005).

Progress on Using NEA Cathodes in an RF Gun, R.P. Fliller, et al., Proc. 2005 PAC, Knoxville TN, 2708 (2005).

Production of Transverse Controllable Laser Density Distribution in Fermilab/NICADD Photoinjector, J. Li, et al., Proc. 2005 PAC, Knoxville TN, 2783 (2005).

Longitudinal Electron Bunch Diagnostics Using Coherent Transition Radiation, D. Mihalcea et al., Proc. 2005 PAC, Knoxville TN, 4254 (2005).

Effects on Flat-Beam Generation from Space-Charge Force and Beamline Errors, Y.-E Sun, K.-J. Kim and P. Piot, Proc. 2005 PAC, Knoxville TN, 3774 (2005).

Upgrade of the Fermilab/NICADD Photoinjector Laboratory, P. Piot et al., Proc. 2005 PAC, Knoxville TN, 2848 (2005).

Simulation of the Laser Acceleration Experiment at the Femilab/NICADD Photoinjector Laboratory, P. Piot et al., Proc. 2005 PAC, Knoxville TN, 2503 (2005).

Photoinjector Production of a Flat Beam with Transverse Emittance Ratio of 100, P. Piot, Y.-E Sun and K.-J. Kim, Submitted to Phys. Rev. Spec. Topics - Accelerators and Beams (December 2005).

Longitudinal Electron Bunch Diagnostics Using Coherent Transition Radiation, D. Mihalcea, et al., Phys. Rev. ST Accel. Beams **9**, 082801 (2006).

Experimental Investigation of the Longitudinal Beam Dynamics in a Photoinjector Using a Two-Macroparticle Bunch, P. Piot et al., Phys. Rev. ST Accel. Beams **9**, 053501 (2006).

Multiresolution Simulations of Photoinjectors, D. Mihalcea, et al., Proceedings of the 2006 Advanced Accelerator Concepts, Lake Geneva, WI, July 2006.

Improved Simulations of Photoinjectors for High-Average Current Free-Electron Lasers, C. L. Bohn, et al., Accepted for publication by Journal of Directed Energy, 2006.

Calculating Emittance for Gaussian and Non-Gaussian Distributions by the Method of Correlations for Slits, C.Y. Tan, Fermilab-TM-2354 (2006).

Status of 3.9 GHz Deflecting-Mode (Crab) Cavity R&D, L. Bellantoni et. al., Linac 2006.

Photoinjector Generation of a Flat Electron Beam with Transverse Emittance Ratio of 100, P. Piot, et al., Phys. Rev. ST Accel. Beams **9**, 031001 (2006).

Master Oscillator for Fermilab ILC Test Accelerator, J. Branlard et al., Linac 2006.

Test of a High Voltage Pulser for ILC Damping Ring Kickers, M. A. Palmer, et al., EPAC06.

Status of 3.9-GHz Superconducting RF Cavity Technology at Fermilab, E. Harms, Linac 2006.

Progress on a Cryogenically Cooled RF Gun Polarized Electron Source, R. P. Fliller and H. Edwards, Linac 2006.

A $1+2(1/2)$ Cell Polarized Electron PWT Photoinjector for the ILC, D. Yu et al., Linac 2006.

Emittance Exchange at the Fermilab/NICADD Photoinjector, T. Koeth et al., Linac 2006.

Capture Cavity II at Fermilab, T. Koeth et al., Linac 2006.

General Solutions for a Transverse to Longitudinal Emittance Exchange Beamline, R. P. Fliller, Fermilab Beams Document 2553 (2006).

Low Emittance Electron Beam Studies, R Tikhoplav, Ph. D. Thesis, University of Rochester, (2006).

Performance of the Upgraded Laser System for the Fermilab-NIU Photoinjector J-L. Li et al., NIMA **564**, 57 (2006).

E-891 Cryogenic Dark Matter Search (CDMS)

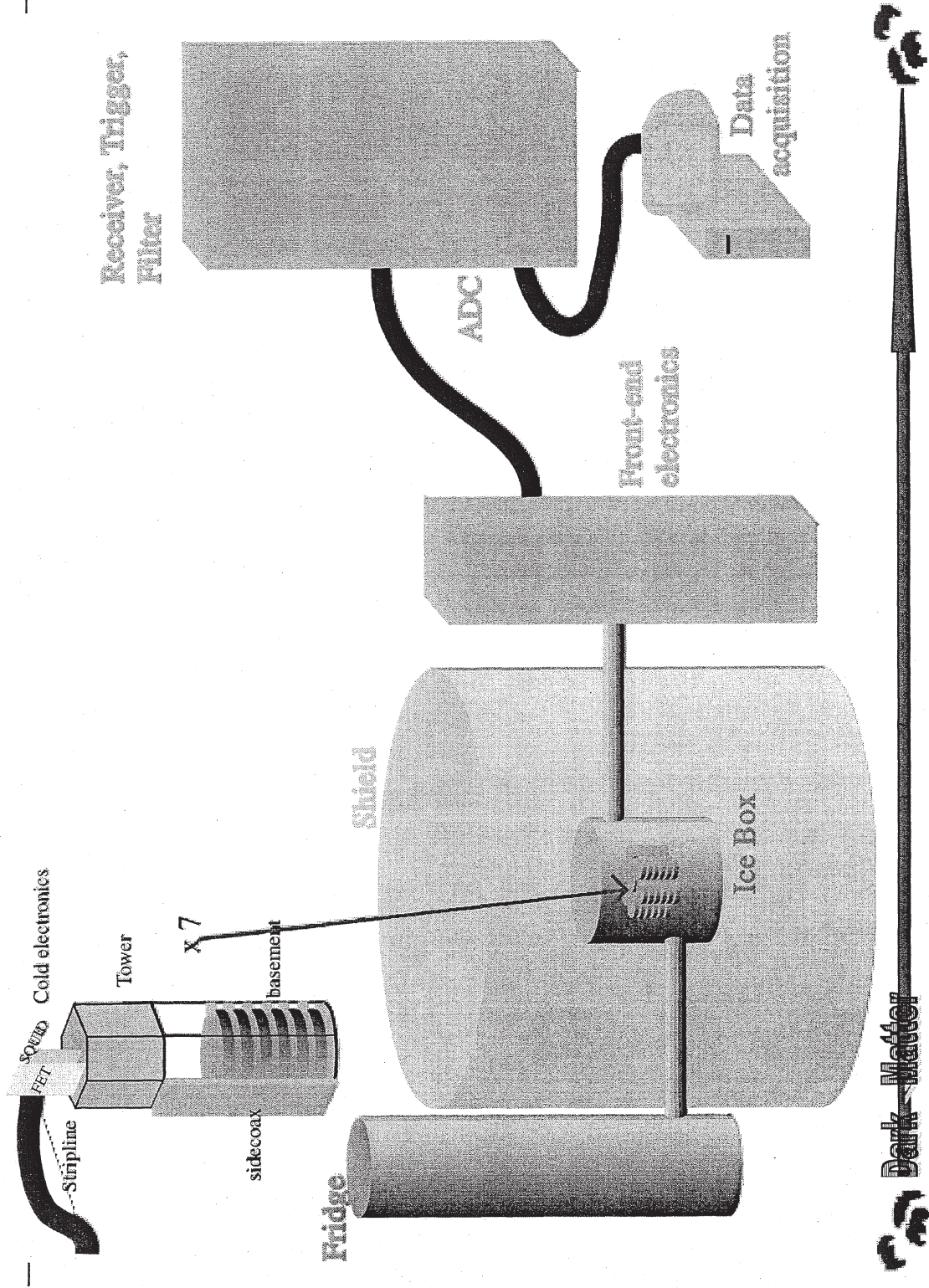

E-891 (Bauer) Cryogenic Dark Matter Search (CDMS)*Fermilab**(and Brown, UC/Berkeley, UC/Santa Barbara, Case Western Reserve,
Colorado/Denver, Florida, LBNL, Minnesota, NIST/Boulder, Santa Clara, Stanford)***Status:** *Data-Taking*

CDMS is an experiment searching for particles that may constitute “dark matter”. There are good reasons to believe that most of the matter in the universe is detected only gravitationally, and does not emit or absorb substantial amounts of electromagnetic radiation at any known wavelength. The nature of this dark matter is unknown. However, there is some evidence that suggests that the dark matter consists of as yet undiscovered weakly interacting massive particles (WIMPs) that were produced in the early universe. If this is true, then we are immersed in a sea of relic WIMPs that occasionally interact with atomic nuclei as they traverse the Earth. The direct observation of the interaction of WIMPs in a terrestrial detector would enable the properties of the dark matter to be measured, and advance our understanding of the physics of elementary particles and the evolution of the early universe.

CDMS employs a new class of elementary particle detectors based on the propagation and detection of phonons in silicon or germanium crystals at temperatures below 0.05K. CDMS is the first experiment capable of searching for WIMPs that have properties and fluxes consistent with current expectations from particle physics and cosmology. The current version of the experiment (CDMS II) is located in the low background environment of the Soudan mine in Minnesota. A proposed new experiment, SuperCDMS 25 kg, will be located in the deeper SNOLAB facility in Sudbury, Ontario, Canada.

Status

Last year, we installed the full CDMS II payload of detectors including 4.5 kg of Ge and 1.1 kg of Si. Having two target materials helps to distinguish between a possible WIMP signal and backgrounds from neutron interactions. A WIMP signature would be single interactions in the Ge detectors only.

Unfortunately, we found that the detectors were unable to reach a sufficiently low temperature to operate at first. This was traced to inadequate thermal connections from the detectors to the dilution refrigerator. We also had problems with ice blockages developing in the circulation system of the refrigerator. It took about six months to identify and eliminate these problems, but we successfully reached operating temperature in July 2006. After careful tuning of the detector performance, we began taking WIMP-search data in October 2006.

We expect to be taking data throughout 2007 and 2008, resulting in an additional improvement of a factor of 10 in sensitivity to WIMPs. This will probe deeply into the predicted region for the neutralino, a WIMP candidate expected from Supersymmetry. Detection of WIMPs with CDMS II would clearly establish that they constitute most of the matter of the universe.

In parallel, we have submitted the SuperCDMS 25 kg proposal to DOE and NSF. The proposed experiment would contain more than five times the detector mass of CDMS II and run twice as long, giving another factor of 10 improvement in WIMP sensitivity by 2012.

E-892

US CMS Management Responsibilities

- US CMS Strategy:
- Complete Projects
 - Vertical Integration

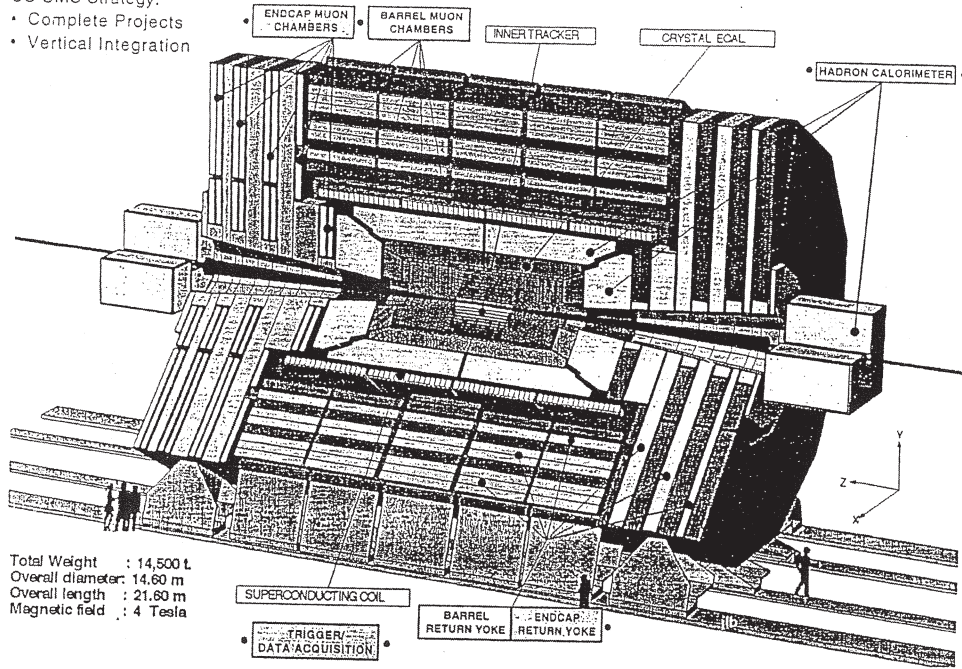

Total Weight : 14,500 t
 Overall diameter: 14.60 m
 Overall length : 21.60 m
 Magnetic field : 4 Tesla

US CMS Construction Responsibilities

- Complete and Coherent Projects:
- Forward Muon Detector
 - Barrel Hadron Calorimeter
 - EMU and HCAL Level 1 Triggers
 - DAQ Event Builder
 - HF, HV, ECAL Readouts
 - Endcap Pixel Detector
 - ECAL Crystal Industrialization

- Common Projects:
- Endcap Return Yoke
 - Solenoid Vacuum Tank

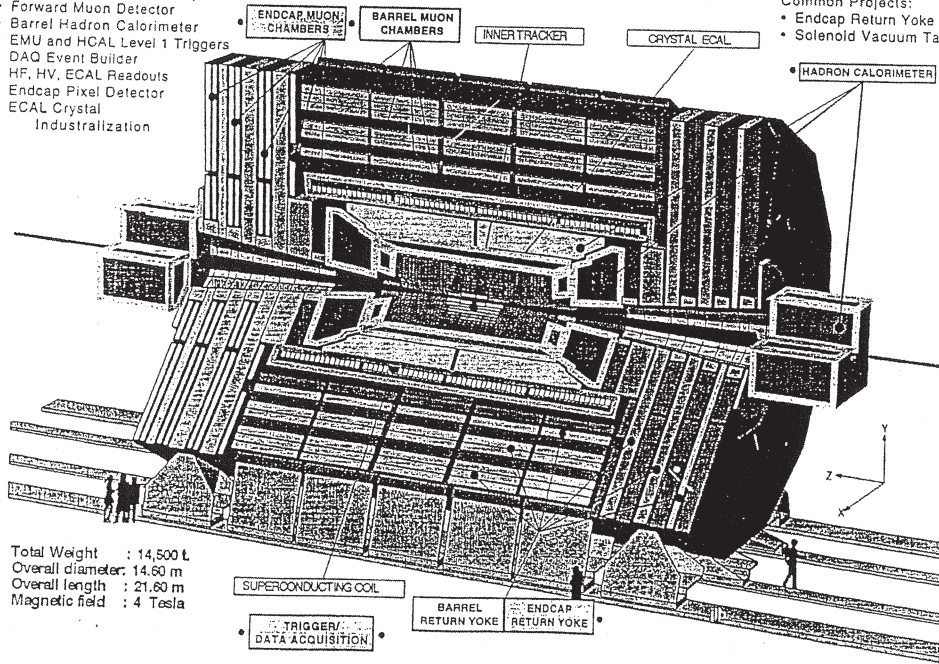

Total Weight : 14,500 t
 Overall diameter: 14.60 m
 Overall length : 21.60 m
 Magnetic field : 4 Tesla

E-892 / 919 (Butler) The US CMS Collaboration at Fermilab

*Fermilab
(and 49 other US institutions)*

Status: No Data Yet

The Compact Muon Solenoid (CMS) is one of two high p_t experiments to be built at the CERN Large Hadron Collider (LHC). The primary physics goal of CMS is to explore electroweak symmetry breaking – the origin of mass. To that end, the basic philosophy of CMS is to enclose the tracking and calorimetry inside a strong Solenoidal magnet. This design allows for a Compact design allowing optimal Muon detection without compromise to the electromagnetic calorimetry because of inert material. In general CMS is optimized for electrons, photons, muons, neutrinos and jets. The Higgs decay modes, $H \rightarrow ZZ \rightarrow l^+l^-l^+l^-$, imply an emphasis on lepton detection. At the high luminosities to be used at the LHC, the charged lepton of choice is the muon due to its relatively clean signature. Neutrinos and jets may also be used in higher-rate but also higher-background signatures, $H \rightarrow ZZ \rightarrow ll\nu\nu$, $H \rightarrow WW \rightarrow jjlv$.

There are about 2600 scientists in the CMS Collaboration who plan to build the detector for a cost of around 500 M Swiss Francs. The detector is to be built from 1997 until data-taking in 2007. The composition of CMS is roughly 50% physicists from member states, 20% from Russia and other non-member states, and 30% US groups. The US CMS Collaboration consists of about 700 physicists and engineers from 50 institutions. The collective goal of this group is to pursue high energy physics at the energy frontier which will be available at CMS. We find the physics opportunities compelling.

Test beam data has been taken each year since 1995 by subgroups of US CMS involved in Hadron Calorimetry (HCAL), Endcap Muon Chambers (EMU), Electro-magnetic Calorimetry (ECAL) and Tracking. The Fermilab group is particularly active in HCAL, EMU and tracking. All subsystems have produced full Technical Design Reports, and have fabricated preproduction prototypes. The CMS Fermilab group is heavily involved in test beam R&D, in engineering design, and in detector construction and commissioning.

Fermilab has also accepted to act as the "host laboratory" for the US CMS collaboration. Therefore, Fermilab will provide a focal point for US CMS. The Project Management of US CMS is centralized and located at Fermilab. The intent is to utilize existing infrastructure at Fermilab. In addition, the fact that Fermilab is the location of the US HEP hadronic collider program, means that the synergy between CDF and D0 and CMS design and construction is available. For example, high-rate triggering and data acquisition is an area where Fermilab will contribute expertise and experience to CMS.

In turn, working on CMS will enhance the art of detector building in the US, especially in the demanding environment found in high-luminosity hadron colliders. The operational experience obtained at CDF and D0 is crucial in ensuring a realistic detector design for CMS. In addition, the use of Fermilab facilities by university groups represents a low-cost way for Fermilab to support university groups within the US CMS Collaboration. A good example is the production of silicon strip detectors and pixel detectors for CMS.

Fermilab has considerable experience operating computing farms of workstations as a cost effective method of providing analysis power to CDF and D0. It is thought that this expertise will translate well to support of US CMS. Clearly, the decade-long experience of Fermilab in the running of the US hadron collider experimental program makes it a natural nucleation point. Fermilab will be a "Tier 1" center for the analysis and distribution of CMS data for the US CMS collaboration.

Experience on existing hadron collider experiments at Fermilab and CERN and on the R&D associated with the SSC makes it possible for US physicists to have a major impact on the design of CMS. US physicists have been assigned distinct and coherent managerial and construction responsibilities as seen in the accompanying figures. We are the managers for the HCAL, EMU, and trigger subsystems. Fermilab also hosts the LHC Physics Center and a remote operations center in Wilson Hall.

The US groups also take proportional responsibilities for the costs of common projects, such as the solenoid. Specifically, US physicists have positions of responsibility for the solenoid vacuum vessel and the endcap steel return yoke. In addition, Fermilab has completed procurement of the conductor and stabilizing aluminum for the solenoid. The aim is to provide in-kind contributions to CMS, but bid and bought in the US.

The experiment is presently scheduled to commence in 2007. It will subsequently have at least a decade lifetime, the LHC being at present the sole facility in the world capable of addressing the physics at the TeV mass scale. A Memorandum of Understanding (MOU) for CMS has been signed by US and CERN representatives which defines the US deliverables. A plan for a ten-fold luminosity increase of the LHC is being formulated. That upgrade should extend the useful life of the LHC by another decade. US CMS physicists will be fully engaged in the design and fabrication of the upgrade.

E-898

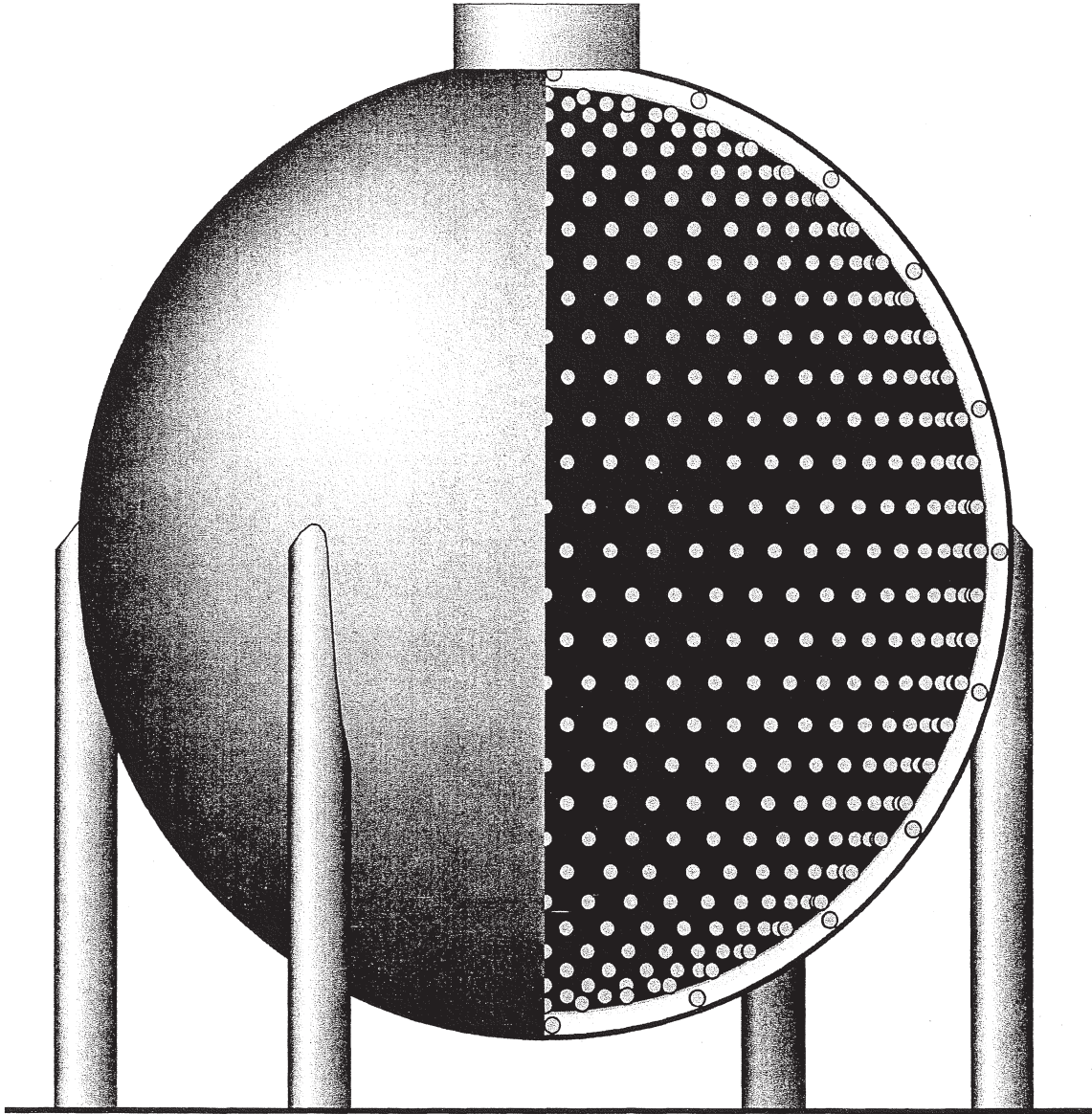

Schematic drawing of the BooNE spherical tank

E-898 (Conrad / Louis) / E-944 (Brice / Van De Water)
Booster Neutrino Experiment

*Alabama, Bucknell, Cincinnati, Colorado, Columbia, Embry Riddle, Fermilab,
 Imperial College London (United Kingdom), Indiana, LANL, Louisiana State,
 Michigan, Princeton, St. Mary's, VPI, Western Illinois, Yale*

Status: E-898: <i>Data Analysis</i> E-944: <i>Data-Taking</i>

The MiniBooNE experiment is motivated by the LSND observation, which has been interpreted as $\bar{\nu}_\mu \rightarrow \bar{\nu}_e$, and by the atmospheric neutrino deficit which may be ascribed to ν_μ oscillations. MiniBooNE is a single detector experiment designed to: obtain ~ 500 events per year if the LSND signal is due to $\nu_\mu \rightarrow \nu_e$ oscillations, establishing the oscillation signal at the $>5\sigma$ level; extend the search for $\nu_\mu \rightarrow \nu_e$ oscillations significantly beyond what has been studied previously if no signal is observed; search for ν_μ disappearance to address the atmospheric neutrino deficit with a signal that is a suppression of the reconstructed 500,000 $\nu_\mu C \rightarrow \mu N$ events per year; and test CP and CPT violation in the lepton sector if oscillations are observed by running with separate ν_μ and $\bar{\nu}_\mu$ beams.

The detector consists of a spherical tank 20 feet in radius, as shown in the accompanying figure. An inner structure at 5.7 m radius supports 1280 8-inch phototubes (10% coverage) pointed inward and optically isolated from the outer region of the tank. The vessel is filled with 800 t of mineral oil, resulting in a 445 t fiducial volume. The outer volume serves as a veto shield for identifying particles both entering and leaving the detector, with 240 phototubes mounted on the support structure facing outwards. The detector is located 500 m from the Booster neutrino source.

The neutrino beam, constructed using the 8 GeV proton Booster at Fermilab, consists of a Be target within a focusing system, followed by a ~ 50 m-long pion decay volume. The low-energy, high-intensity and $1\mu s$ time-structure of a neutrino beam produced from the Booster beam are ideal for this experiment. The Booster is a highly reliable machine, with a downtime of $\sim 1.5\%$, thus we assume that the Booster can reliably deliver protons for a typical run which is two-thirds of a calendar year. The sensitivities discussed above assume the experiment receives 5 Hz for $2 \times 10^7 s$ running at 5×10^{12} protons per pulse. This Booster experiment is compatible with the Fermilab Collider and Main Injector programs. The Booster must run at 7.5 Hz to accommodate the MiniBooNE, NuMI and Collider programs simultaneously. The Fermilab Booster is capable of running at 15 Hz.

The detector was filled with oil in May 2002, and then began taking cosmic-ray data. The beamline was completed in late August 2002, and the first neutrino-induced events were observed over Labor Day weekend 2002. As of January 2006, about 7×10^{20} POT and over 700,000 neutrino events have been

recorded in neutrino mode. The detector, horn, and neutrino beamline are all working well.

There has been considerable progress in the analysis of the neutrino data in 2006. The reconstructed event position, angular, and energy resolutions are all consistent with expectations, and π^0 s are being reconstructed with the correct mass and the expected width. Furthermore, the experiment is clearly reconstructing charged-current quasi-elastic events, neutral-current π^0 events, and neutral-current elastic events. These classes of events are interesting in their own right; they show that the experiment is working well, and they are on the direct path to the analysis of the oscillation data. Extensive work is now focusing on flux, cross section, and electron particle ID systematic errors and will culminate in publication of oscillation results during 2007.

On January 9, 2006, the neutrino run was terminated, and the horn power supply polarity was switched. This signals the start of anti-neutrino running (E-944), which will last through 2006. The anti-neutrino data set anticipated will be the world's largest by an order of magnitude, and will allow important measurements of anti-neutrino cross sections and systematic checks of the neutrino oscillation analysis. In 2006 about 1.5×10^{20} POT was successfully collected. However, a problem with the 25m absorber in the decay pipe region was discovered. Two (of eleven total) 25 ton absorber plates had fallen into the decay region due to hydrogen embrittlement of the support chains. This resulted in an overall decrease in the neutrino rate on the order of 25%. This configuration change affects most of the antineutrino data. Efforts are currently underway to repair the 25m absorber region and put the plates back into the up position, resulting in a three-month shutdown. Efforts on the analysis of the antineutrino data and modeling of the effects of the partially deployed absorber are showing that we can recover this data and it will be usable for the measurements that were anticipated.

E-906

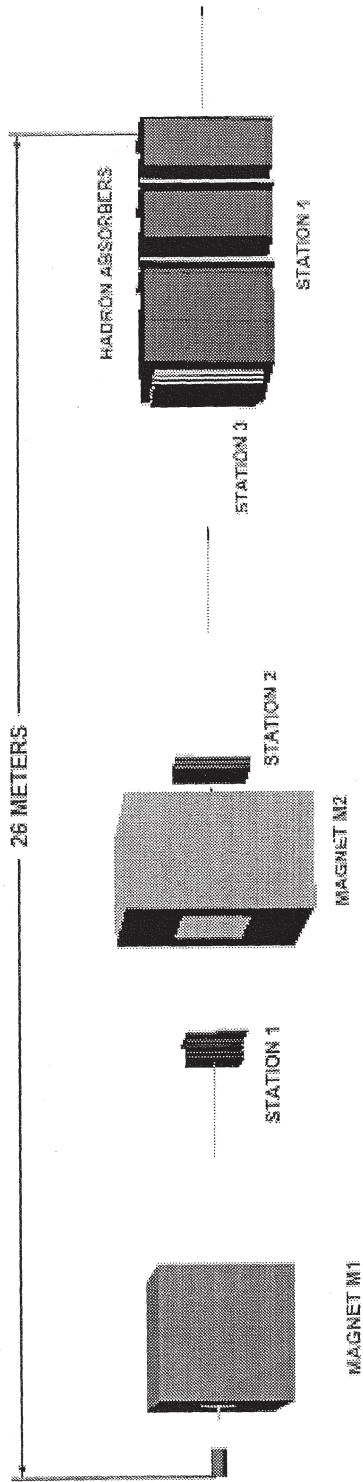

E-906 (Geesaman / Reimer) Drell-Yan Measurement of the Anti-quark Sea

*Abilene Christian, ANL, Colorado, Fermilab,
Illinois, JLab, LANL, Maryland, Rutgers, Texas A&M, Valparaiso*

Status: <i>No Data Yet</i>

Experiment E-906 will measure the asymmetry between anti-up and anti-down quarks in the proton. This experiment is motivated by the observation of E-866/NuSea that showed a large difference between the anti-up and anti-down distributions as a function of Bjorken- x , the momentum carried by the struck quark. The new experiment is designed to be able to reach much larger values of x than previous experiments. The distribution of these sea quarks and the asymmetry between anti-up and anti-down quarks provides important clues to the origin of the proton's sea, and in particular, the way in which both perturbative and non-perturbative processes conspire to generate the proton's sea quarks.

The sea quarks in the proton are probed using the Drell-Yan process, in which a quark (or anti-quark) in the beam annihilates with an anti-quark (or quark) in the target, producing a pair of oppositely charged muons, which are detected in the apparatus. The acceptance of the detector is designed to primarily see events involving the target anti-quarks. By changing between hydrogen (proton) and deuterium (proton and neutron) targets, the experiment will be able to compare the proton and neutron's sea quark distributions and with the addition of isospin symmetry, extract the ratio of anti-down to anti-up quarks in the proton.

Additionally, by collecting Drell-Yan data with nuclear targets, the experiment will be able to measure the energy loss of quarks traveling through cold nuclear matter. Previous measurements have shown that this energy loss is much smaller than expected, and were only able to set upper limits on the energy loss. E-906 will be able to measure this energy loss and distinguish between competing models of the energy loss process. The nuclear target data is also important to understand any systematic effects in the deuterium measurements.

E-906 will use a beam of 120 GeV protons extracted from the Main Injector. The Drell-Yan cross section with the lower-energy 120 GeV proton beam is *larger* than the cross section at 800 GeV, giving the experiment greater statistical reach. At the same time, the primary background, muons from J/ψ decays, is reduced at the lower beam energy.

The apparatus is a two-magnet spectrometer. The upstream magnet focuses the muon pair into the detector and sweeps other particles produced in the collision out of the way. Inside this magnet will be a large wall of material, through which the muons are able to pass, and in which other particles will

interact. The design of the coils for this magnet is underway. Downstream of the magnet are tracking chambers, trigger hodoscopes and a second magnet, used to measure the momentum loss of each of the muons. At the downstream end of the experiment is additional material that absorbs hadrons and electrons. A final set of tracking chambers will identify the muons. Overall, the apparatus is approximately 26 m long and the final tracking stations are approximately 3 m². The general layout of the detector resembles a shortened version of the E-866/NuSea spectrometer and much of the detector is being reused from previous experiments; however, the vastly different energy of the proton beams requires that a new magnet be constructed to focus the muons.

MIPP

Main Injector Particle Production Experiment (FNAL-E907)

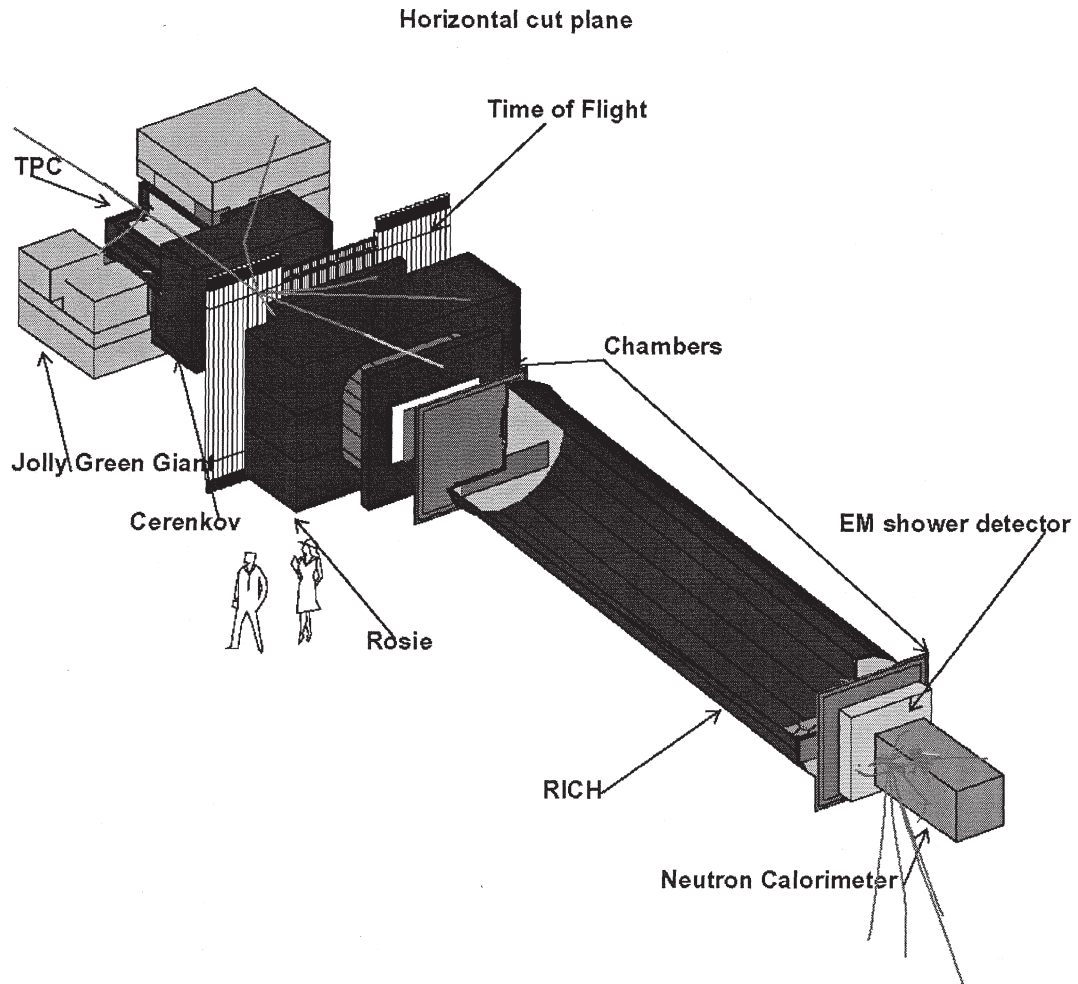

The MIPP apparatus

E-907 (Raja) MIPP – Main Injector Particle Production Experiment

*BNL, Chicago, Colorado, Elmhurst, Fermilab, Harvard, IIT,
Indiana, Iowa, LLNL, Michigan, Purdue, South Carolina, Virginia*

Status: *Data Analysis*

The MIPP experiment (Fermilab E-907) is designed to measure particle production using Main Injector secondary beams (π^\pm , K^\pm , p^\pm with beam momenta ranging from 5 GeV/c to 90 GeV/c) over a variety of targets ranging from hydrogen to beryllium, carbon and heavy nuclei. The centerpiece of the experiment is a time projection chamber (TPC) capable of detecting particles over nearly 4π acceptance. Using a combination of dE/dx , time of flight, Cerenkov and RICH detector, MIPP will identify the charged particles in the final state. With this data MIPP hopes to restart the study of non-perturbative QCD interactions as well as to measure cross sections in nuclei for the purpose of proton radiography and nuclear physics. A critical measurement MIPP will make is that of particle production from the NuMI target, which will be beneficial to all neutrino experiments using the NuMI beam (MINOS, MINERvA, NOvA).

E-907 finished its data-taking run in February 2006, having run a year with the TPC data acquisition speed at an average of ~ 25 Hz. Data was acquired over a variety of targets including liquid hydrogen, the NuMI target and various thin target nuclei. We recorded ~ 18 million events in this mode. During the last month of the run, the Jolly Green Giant magnet coils shorted out and we switched off the TPC and took data at ~ 300 Hz to try and measure the charged kaon mass using the ring radii in the RICH. Table 1 gives the summary of the data taken as a function of target and beam momentum.

Data Summary 27 February 2006			Acquired Data by Target and Beam Energy Number of events, $\times 10^6$										
Target			E										
Z	Element	Trigger Mix	5	20	35	40	55	60	65	85	120	Total	
0	Empty	Normal		0.10	0.14			0.52				0.25	1.01
	K Mass	No Int.				5.48	0.50	7.39	0.96				14.33
	Empty LH	Normal		0.30				0.61		0.31			7.08
1	LH	Normal	0.21	1.94				1.98		1.73			
4	Be	p only										1.08	1.75
		Normal			0.10			0.56					
6	C	Mixed						0.21					1.33
	C 2%	Mixed		0.39				0.26			0.47		
	NuMI	p only									1.78	1.78	
13	Al	Normal			0.10								0.10
83	Bi	p only										1.05	2.83
		Normal			0.52			1.26					
92	U	Normal						1.18					1.18
Total			0.21	2.73	0.86	5.48	0.50	13.97	0.96	2.04	4.63	31.38	

Table 1. Summary of data taken during MIPP Physics Run.

E-929

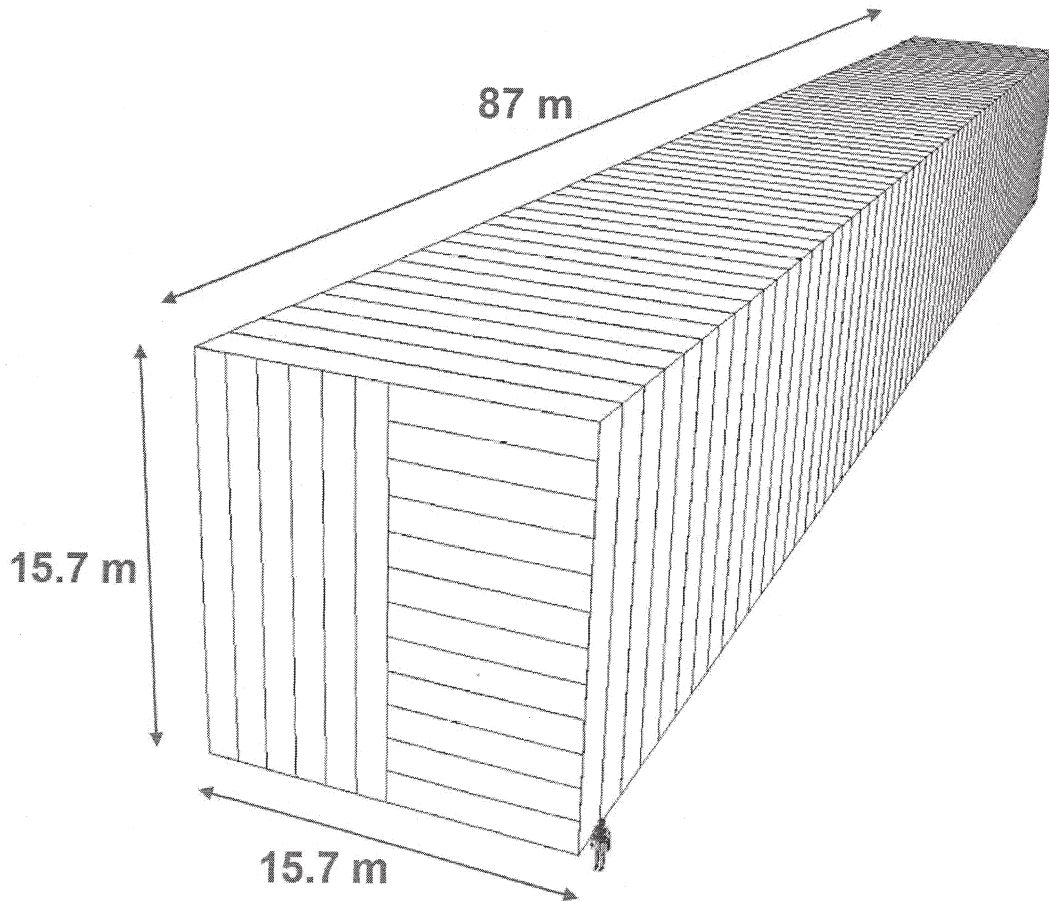

Schematic drawing of the NOvA far detector showing 42 blocks of 31 planes. The cut-away view of the front plane shows the alternating layers of horizontal and vertical extrusion modules.

E-929 (Feldman / Messier) NuMI Off-Axis ν_e Appearance Experiment (NO ν A)

ANL, Athens (Greece), UCLA, Caltech, Fermilab, Collège de France (France), Harvard, Indiana, ITEP (Russia), Michigan State, Minnesota / Twin Cities, Minnesota / Duluth, Northern Illinois, Ohio State, Rio de Janeiro (Brazil), South Carolina, Southern Methodist, Stanford, Texas A&M, Texas / Austin, Texas / Dallas, Tufts, Virginia, William & Mary

Status: <i>No Data Yet</i>

NO ν A is a second-generation neutrino oscillation experiment on the NuMI beam line. Its primary physics goal is the study of $\nu_\mu \rightarrow \nu_e$ oscillations with approximately an order of magnitude more sensitivity than that of the MINOS experiment. The study of $\nu_\mu \rightarrow \nu_e$ oscillations allows the measurement of $\sin^2(2\theta_{13})$, the ordering of the neutrino masses, and CP violation. The $3\text{-}\sigma$ discovery sensitivity to $\sin^2(2\theta_{13})$ will be between 0.01 and 0.02, depending on the other parameters. NO ν A has been optimized for the measurement of the mass ordering, which requires a very long baseline experiment. Other NO ν A physics goals include the precision measurement of the dominant atmospheric parameters, $\sin^2(2\theta_{23})$ and Δm_{32}^2 , and the detection of galactic supernovae.

NO ν A is a two-detector experiment, with the near detector at Fermilab in the NuMI access tunnel upstream of the MINOS access shaft, and the far detector 810 km from Fermilab near Ash River, Minnesota. The detectors are placed approximately 15 mrad off of the axis of the NuMI beamline. The off-axis position allows for more flux at the oscillation maximum and less background from neutral current and ν_e charged current events.

The NO ν A far detector has a mass of 20 kT and is composed solely of liquid scintillator contained in PVC extrusion modules. Each extrusion module is 15.7 m long and has 32 cells. The cell dimensions are 3.9 cm transverse and 6 cm longitudinal. There are 12 extrusions per plane and 1302 planes, with planes alternating in horizontal and vertical orientations. Each cell is read out by a U-shaped wavelength-shifting fiber, both of whose ends terminate on the same pixel of a 32-pixel avalanche photodiode.

The NO ν A near detector design is identical to that of the far detector except that the extrusion modules are shorter to accommodate the restrictions of the NuMI access tunnel. The planes are 2 extrusion modules wide and 3 extrusion modules tall. There are 202 planes divided into an 8-plane veto region, a 112-plane fiducial region, a 72-plane shower containment region, and a 10-plane muon tagger. The muon tagger has 10 cm of iron in front of each plane of extrusion modules.

NO ν A received Stage I approval in April 2005. In 2006, it wrote a Conceptual Design Report and passed a CD-1 review. In 2007, it will prepare a

Technical Design Report and have a CD-2/3a review in preparation for a FY2008 project start. The NOvA Project now includes both the NOvA Detectors and the accelerator and NuMI upgrades to allow operation at 700 kW beam power. The project was listed in the President's FY2008 budget request for a total project cost of \$260M. With a FY2008 start and the present funding profile, NOvA would begin taking data on the partial far detector in 2011.

E-938

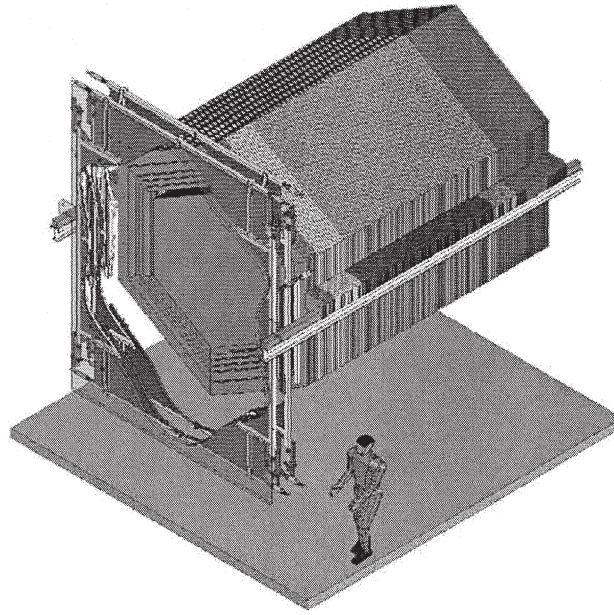
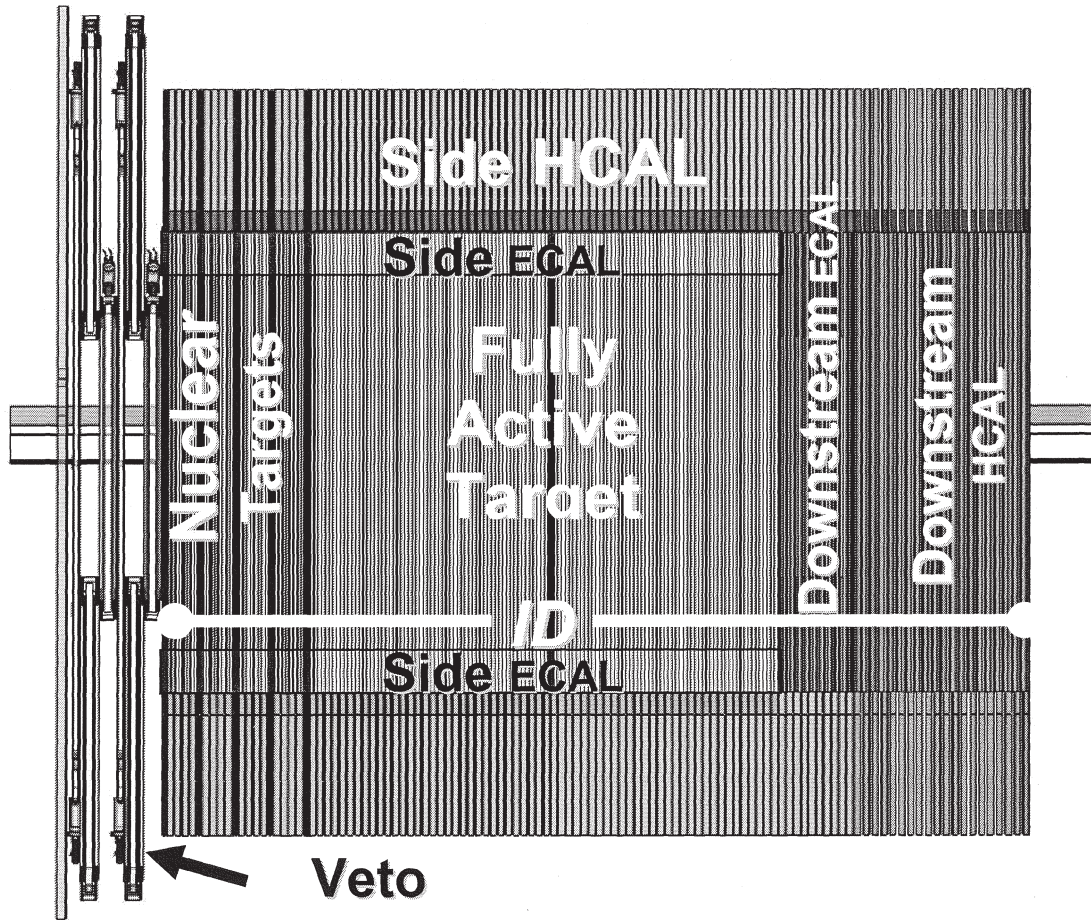

A side-view schematic of the MINERvA detector, without the upstream liquid helium vessel, and an outline to illustrate shape and scale.

E-938 (McFarland / Morfin) The MINERvA Experiment

*Athens (Greece), UC/Irvine, Dortmund (Germany), Fermilab, Hampton, IIT,
INR Moscow (Russia), James Madison, JLab, Minnesota/Duluth, Northern Illinois,
Northwestern, Pittsburgh, PUCP (Peru), Rochester, Rutgers, St. Xavier,
Texas/Austin, Tufts, UNI (Peru), William & Mary*

Status: No Data Yet

The NuMI neutrino facility, designed for the MINOS neutrino oscillation experiment, is yielding several orders of magnitude more events per kg of detector per year of exposure than the higher-energy Tevatron neutrino beam. This dramatic increase in intensity will allow us to initiate a vigorous neutrino scattering research program at a detector located close to the production target. One can now perform statistically significant experiments with much lighter and more fine-grained detector/targets than the massive iron, marble and other high-A detector materials used in the past.

To take advantage of the NuMI beam and facility, a collaboration of elementary particle and nuclear physics groups and institutions named MINERvA (Main INjector ExpeRiment v--A) has been formed. The overall goal of the MINERvA experiment is to perform a high-statistics neutrino-nucleus scattering experiment using a relatively compact and active target/detector consisting of a central section of essentially solid scintillator bars. This central detector is surrounded on all sides by an electromagnetic calorimeter and a hadronic calorimeter/muon-identifier. The detector has the approximate overall shape of a hexagon (to permit three stereo views) with a cross-section of 3.55 m minor and 4.10 m major axis. The active plastic scintillator volume is 6.1 tons allowing variable-sized fiducial volumes depending on the physics channel being studied. At the upstream end of the detector are nuclear targets consisting of a liquid helium vessel, as well as C, Fe and Pb solid targets. The length, without the liquid helium vessel and upstream veto counters, is 4.7 m. Significant vertex-reconstruction accuracy without excessive granularity can be achieved by the use of triangular-shaped extruded plastic scintillator (CH) bars with an optical fiber run through a centrally located hole for readout. Recent prototype work has shown that using light division across triangularly-shaped scintillator strips of width 3 cm and height 1.7 cm can yield coordinate resolutions of a few millimeters. The orientations of the scintillator strips are alternated so that efficient pattern recognition and tracking can be performed.

The MINERvA detector will be placed as close as possible to the upstream face of the MINOS near detector in order to use that detector's magnetic field and steel as an external muon-identifier and spectrometer for the forward-going muons. With a comparatively simple and straightforward active detector technology, the most complicated parts of MINERvA are the photosensors and their associated readout electronics. The photosensor chosen, a multi-anode photomultiplier tube (MAPMT), is an incremental design improvement from the one used in the MINOS near detector, and we expect much of the experience gained by the MINOS collaboration with these detectors to be applicable. For

the front-end digitization and timing, a scheme based on D0 TriP-T ASIC has been chosen.

MINERvA will run parasitically to the MINOS and the NOvA experiments. Expected event rates depend on the number of protons-on-target delivered by the Main Injector. For a total of 16×10^{20} protons on target, the event rates in the active scintillator central detector range from thousands for the weak analog of deeply virtual Compton scattering, tens of thousands for coherent pion production and exclusive strange particle production channels, close to a million for quasi-elastic and resonance production, to several million deeply-inelastic scattering events. Total event rates on the nuclear targets range from 400 k on C to 2.5 M on Pb.

E-939

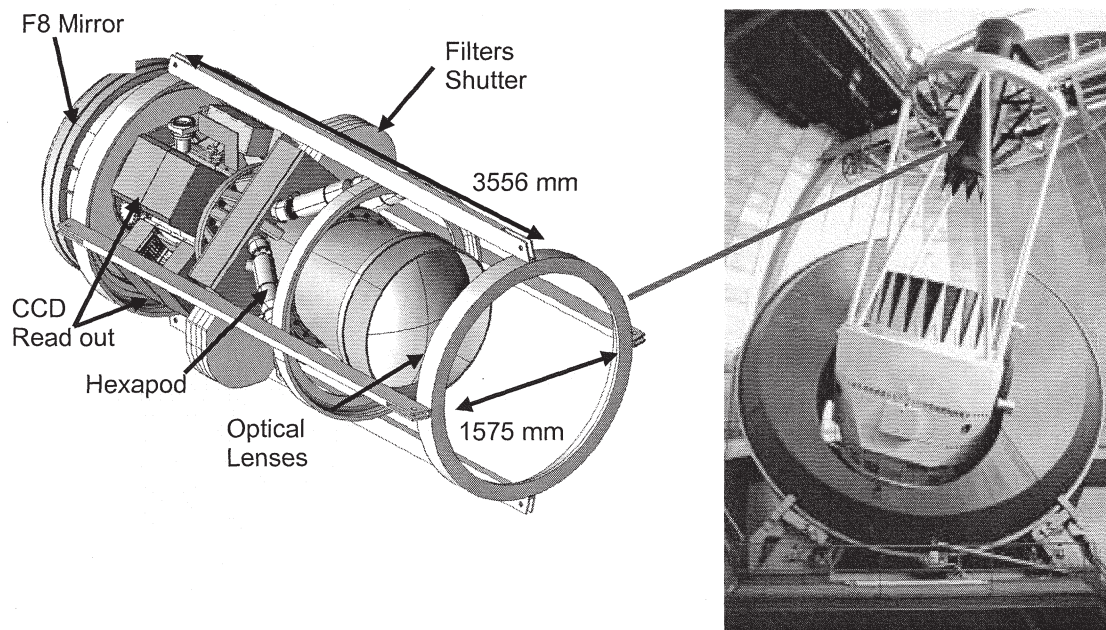

The Dark Energy Survey instrument and the Blanco telescope. The overall length of the prime focus cage is 3.543 m and the diameter is 1.575 m.

E-939 (Annis / Flaugher) The Dark Energy Survey (DES)*Fermilab**(and ANL, Brazil DES Consortium of Scientists, Chicago, CTIO, Illinois, LBNL, Michigan, Ohio State, Pennsylvania, Spain DES Collaboration [IEEC, IFAE, CIEMAT], United Kingdom DES Collaboration [Cambridge, Edinburgh, Portsmouth, Sussex], Univ. Coll. London)***Status: No Data Yet**

A critical research problem in cosmology is the drive to understand the recent observation that the expansion of the Universe is accelerating. In 1998, two independent teams studying distant type Ia supernovae observed that they appeared dimmer than expected. This dimness was attributed to an acceleration of the universal expansion. Since the mutual gravitational attraction of galaxies and their dark matter halos decelerates the expansion, something new and strange is required to give rise to acceleration: dark energy.

Since then, independent lines of evidence for dark energy have been found. Most recently, the high precision measurements of the temperature fluctuations of the cosmic microwave background (CMB) made with the NASA Wilkinson Microwave Anisotropy Probe (WMAP), in combination with measurements of the large-scale galaxy distribution by the Sloan Digital Sky Survey (Fermilab experiment E-885), have determined that the total matter density, the sum of the normal and dark matter densities, is equal to about 30 percent of the total, while the remaining 70 percent of the energy density must be attributed to the dark energy. This evidence for dark energy is independent of and in agreement with the supernova studies.

The dark energy could be vacuum energy (the “cosmological constant”), a new scalar field, or it could signal a flaw in Einstein’s general relativity, e.g., that could arise if our three-dimensional world is embedded in a higher-dimensional universe. Any of these possibilities would represent a major shift in our fundamental understanding of the nature of matter, energy, space, and time. To sort out the possibilities and pin down the nature of the dark energy, more precise measurements will be needed of the dark energy equation of state parameter, w , and its evolution with redshift. In order to make such measurements, new methods and new instruments are needed.

The principal scientific objective of DES is to provide new and tight constraints on the nature of dark energy. In order to unify the discussions of the nature of dark energy, the Dark Energy Task Force (DETF) chose to parameterize the dark energy equation of state, w , in terms of w_0 , its present value, and w_a , which represents the possible time evolution of dark energy. The current limits on w cannot distinguish between a constant or non-constant w . The DETF defined a figure of merit (FOM) based on the combined uncertainties anticipated for w_0 and w_a . Using this FOM, they concluded that, given uncertainties in projected systematic errors, no single dark energy measurement

could robustly constrain both parameters. Rather, they concluded that tight constraints would need to come from multiple dark energy probes. The DES will measure w with the four complementary techniques recommended by the DETF and provide at least a factor of 4.6 improvement in the figure of merit over current projects.

The four independent methods which DES will use for measuring w are galaxy cluster counts, weak gravitational lensing tomography, galaxy angular clustering (baryon acoustic oscillations), and supernova distances. The use of four methods is doubly complementary: Each is sensitive to w_0 and w_a in different ways and is subject to different types of measurement uncertainties. By deriving four separate measurements from the same data set with a common analysis framework, the DES will obtain important cross checks of both the theory and the systematic errors and thereby make a substantial and robust advance in the understanding of dark energy. In particular, this approach should enable the collaboration to begin to distinguish among different types of explanation for dark energy—something which is not possible with the current state of experimental measurements.

The DES scientific goals require the observation of an area of sky covering 5,000 square degrees of the Southern Galactic Cap to a magnitude (brightness) limit of about 24 in each of four filter band passes using approximately 109 nights per year for five years. To meet these goals, the DECam project (led by Fermilab) will build a 519 megapixel optical CCD camera, a 2.2 degree field-of-view optical corrector with a four-band filter system (g, r, i, z filters) and the associated electronics, cooling and controls systems to operate it. The camera focal plane will consist of sixty-two 2,048 by 4,096 pixel CCDs (0.27 arc-seconds/pixel) arranged in a hexagon covering an imaging area of three square degrees. The CCDs are a 250-micron thick design from LBNL with high quantum efficiency at high wavelengths (~ 950 Å) and a diffusion of less than 7.5 microns. The CCD readout system will have less than 10 e⁻ noise at a readout speed of 250 Kpix/sec. The camera and optics will be supported and aligned in a new prime focus cage and controlled by a new image acquisition system that will interface the CCD camera to the observers and to the telescope control system. The filter changing mechanism will include space for the four DECam filters and four non-DES filters (to be supplied by the community).

The DES received CD-0 approval on November 22, 2005. In April 2006 DES came before P5 and in June 2006, P5 recommended to the High Energy Physics Advisory Panel (HEPAP) the start of construction for DES and stated that DES is a project having significant potential for important physics.

Over the last year we have enlarged and deepened our collaboration as the University of Pennsylvania, a consortium of scientists from Brazil, Ohio State University and Argonne National Laboratory have joined our endeavor. We have built a state of the art CCD testing lab, and acquired, packaged and tested more than 75 CCDs. Testing has shown that the CCDs are meeting the specifications and the remaining question is the CCD yield. The electronics and CCD readout systems have been optimized and are already very close to meeting

the noise and speed requirements. In the summer of 2006, the University of Chicago delivered a full-size prototype camera vessel that we will use to test the readout of multiple CCDs in a realistic environment. Readout of a single CCD in the camera achieved low noise after only a couple weeks of chasing the noise sources. The preliminary design of the corrector optics was reviewed in February 2006 and the final design is scheduled for review in February 2007, with procurement of the glass to follow shortly thereafter. The mechanical design of the corrector barrel and cage have progressed and initial modeling studies show that the alignment specifications can be met in all orientations and positions. The simulation team has produced the second round of mock survey realizations with which to test analysis and data reduction methods. The data management team has embarked on the second data challenge.

In July 2006 Fermilab held a CD-1 Director's Review of DES. In the fall of 2006, the collaboration as a whole prepared a combined proposal for submission to NSF and DOE which incorporates information about all aspects of the DES project. We are currently preparing for a Joint NSF/DOE CD-1 Lehman review in April 2007.

The Dark Energy Camera is scheduled to be completed and installed on the Blanco 4 m telescope in 2010. The Dark Energy Survey, the data-taking activity, will proceed over the subsequent five years. The survey will produce an archive that will be available to the public a year after the images are collected. The DES proposal is available at www.darkenergysurvey.org.

E-954

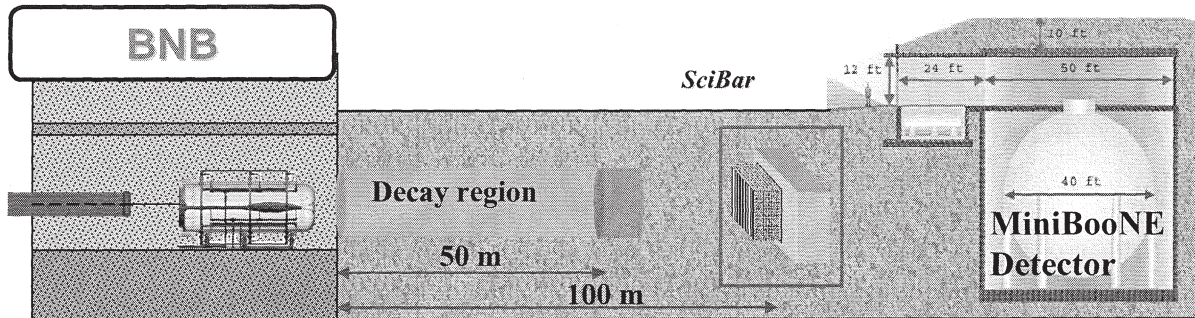

Schematic layout of SciBooNE

The detector sits on the Booster neutrino beamline (BNB) axis, 100 m from the target.

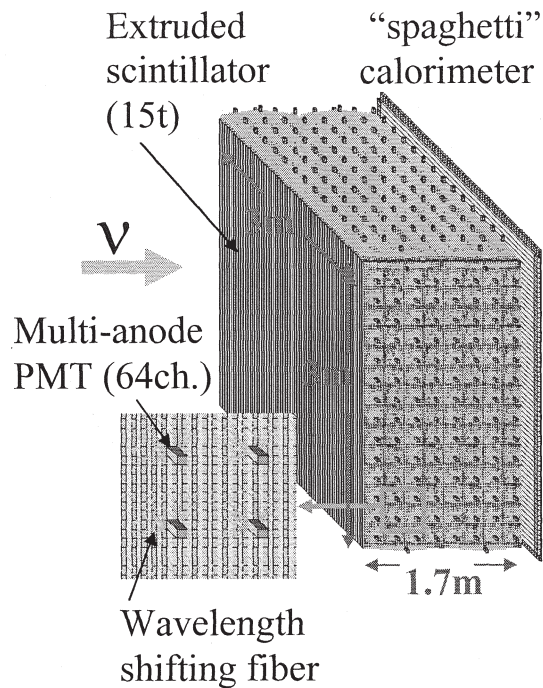

SciBar Detector Schematic

The detector is 15 tons of extruded scintillator, arranged in planes of x and y oriented strips. Each strip is optically isolated from its neighbor and read out by one anode of a multi-anode PMT.

E-954 (Nakaya / Wascko) **SciBar Booster Neutrino Experiment** (SciBooNE)

*Barcelona (Spain), Chonnam (Korea), Cincinnati, Colorado, Columbia, Dongshin (Korea),
Fermilab, ICRP (Japan), Imperial College London (United Kingdom), Indiana,
KEK (Japan), Kyoto (Japan), LANL, Louisiana State, Purdue/Calumet, Rome (Italy),
St. Mary's, Seoul (Korea), Tokyo Inst. Tech. (Japan), Valencia (Spain)*

Status: *No Data Yet*

The SciBooNE collaboration has brought the K2K SciBar detector to the Fermilab Booster Neutrino Beam (BNB) to perform a suite of neutrino and antineutrino cross-section measurements needed for the next generation of neutrino oscillation experiments.

SciBooNE consists of three detector subsystems: SciBar, the electron catcher (EC), and the muon range detector (MRD). SciBar is a fully active neutrino vertex detector which measures the direction and deposited energy of final state particle tracks. Directly downstream of SciBar is the EC, a lead electromagnetic calorimeter designed to tag π^0 s and intrinsic ν_e s. Downstream of the EC is the MRD, which measures the energy of stopping muons. The detector will be placed on-axis in the BNB, 100m from the neutrino target.

There are ~15,000 plastic scintillator strips in SciBar, each 1.3 cm \times 2.5 cm \times 300 cm, in total. The scintillators are arranged vertically and horizontally to construct a 3 m \times 3 m \times 1.7 m volume with a total mass of 15 tons, and a fiducial mass of 9.38 tons. Each strip has a single wavelength-shifting (WLS) fiber running down the center, attached to a 64-channel multi-anode PMT (MA-PMT). Custom electronics provide charge information from each anode and timing information from each MA-PMT.

The EC consists of 32 (vertical) and 30 (horizontal) modules of the so-called "spaghetti calorimeter" from the CHORUS experiment. Each module is made of 1 mm diameter scintillating fibers embedded in the grooves of 1.9 mm thick lead foils. Each module is 4.0 cm \times 8.2 cm \times 262 cm, and is read out by two 1" PMTs on both sides. The EC has a thickness of 11 X_0 along the beam direction, giving it a very high efficiency. The energy resolution of the EC is $14\%/\sqrt{E_e}$.

The MRD consists of 12 planes of 275 cm \times 305 cm \times 5 cm iron plates interspersed with plastic scintillators, 0.6 cm thick in the beam direction. This scintillator is sufficient to detect MIPs with high efficiency, and 60 cm of iron is sufficient to stop muons up to 1 GeV/c.

The fine granularity of SciBar allows detailed reconstruction of final states not possible with large volume Cherenkov calorimeters, like MiniBooNE

or Super-K. Additionally, the BNB neutrino energy spectrum is a close match to the expected T2K energy spectrum in a region where cross sections are expected to vary dramatically with energy. As a result, SciBooNE will provide cross-section measurements in an energy range complementary to MINERvA and complete our knowledge of neutrino cross sections over the entire energy range of interest to the upcoming off-axis experiments.

E-961

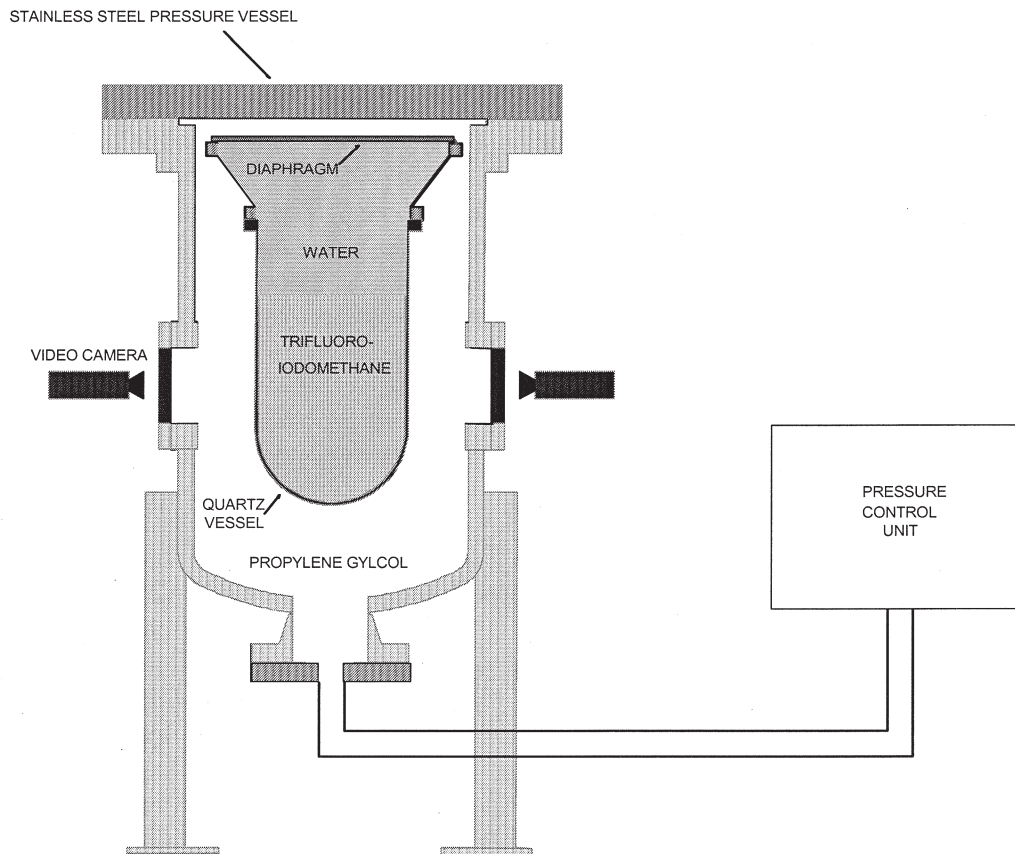

Conceptual design for the 60-kg bubble chamber showing the inner quartz vessel, the pressure balancing diaphragm, the outer pressure vessel, and the external cameras and hydraulic control unit.

**E-961 (Collar) Chicagoland Observatory for Underground
Particle Physics (COUPP)**

Chicago, Fermilab, Indiana

Status: No Data Yet

COUPP uses stable room-temperature bubble chambers to search for Weakly Interacting Massive Particles (WIMPs), which might compose a significant fraction of the galactic Dark Matter. The superheated refrigerant used, CF_3I , is a fire-extinguishing agent and an optimal target for both spin-dependent and spin-independent WIMP couplings. At the moderate degrees of superheat necessary to detect low-energy nuclear recoils like those expected from WIMPs, this fluid exhibits a measured intrinsic rejection of minimum-ionizing backgrounds better than 10^{10} . The metastable superheated state is however sensitive to alpha-recoils, resulting in a requirement to reach ultra-trace levels of elements in the U and Th decay chains within the active volume of the chambers. The eventual goal is to match the radio-purity in U and Th of modern large neutrino detectors.

COUPP presently operates a 2 kg chamber at the ~300 m.w.e. depth of the NuMI tunnel at Fermilab as a test beam precursor of this project (T-945). During T-945 valuable information has been obtained on the presence and control of radon-induced backgrounds. More than 250 kg-days of exposure were collected, demonstrating a stable and reproducible operation of the chamber. The dataset obtained already leads to a very competitive sensitivity to spin-dependent couplings, even in the presence of identifiable backgrounds. Measures against these backgrounds are being implemented at the present time (January 2007). Successful calibrations of the device with gamma and neutron sources were also performed during T-945.

The short-term goals for COUPP are to reduce the alpha-recoil backgrounds in the 2kg chamber to a level of less than one event per kg per day, and to apply the upgrades tested on it to larger chambers currently under construction. A pion beam calibration able to separate the response to iodine and fluorine recoils is planned, using a dedicated chamber. With the addition of a high-efficiency muon veto presently being commissioned, it is in principle possible to reach improved sensitivities to both WIMP couplings in the present Fermilab location. The collaboration is constructing a larger device, totaling up to 60 kg of CF_3I . This detector will undergo tests at shallow depth in the NuMI tunnel, and will be prepared for deployment in a suitable deep-underground location. Devices of this mass will be able to exploit a number of signatures characteristic of WIMP-induced recoils, leading to a diminished sensitivity to alpha and neutron recoils and to a much-improved WIMP sensitivity. We have been charged to assess the scalability of this technique to the deep-underground installation of a target mass of order one ton, using a number of different refrigerant targets immersed in a suitable shielding and leading to an exhaustive exploration of supersymmetric WIMP models.

SECTION VII. MASTER LIST OF PROPOSALS

The Master List of proposals contains an entry for each proposal submitted to Fermilab; a typical entry is explained on the next page. In addition to the formal title of the proposal and a brief parenthetical explanation, the name of the spokesperson and a list of participating institutions are included. In the lower part of each entry the specific requests for running time to complete the experiment are listed together with approval action by the Laboratory. For approved proposals only, the amount of running time granted is given together with the current status and extent of beam time used so far.

Most of the information about each proposal stored in the Program Planning Office data file is given in the Master List; lists of proposals shown elsewhere in this Workbook are based on the information contained in the Master List.

For proposals with number below 700, only those which are approved or unconsidered or deferred are listed in the following pages; those with obsolete status (rejected or withdrawn/inactive) are omitted, which explains the gaps in the sequential listing. The complete listing is given starting with proposal 700.

EXPLANATION OF A TYPICAL ENTRY IN THE MASTER LIST

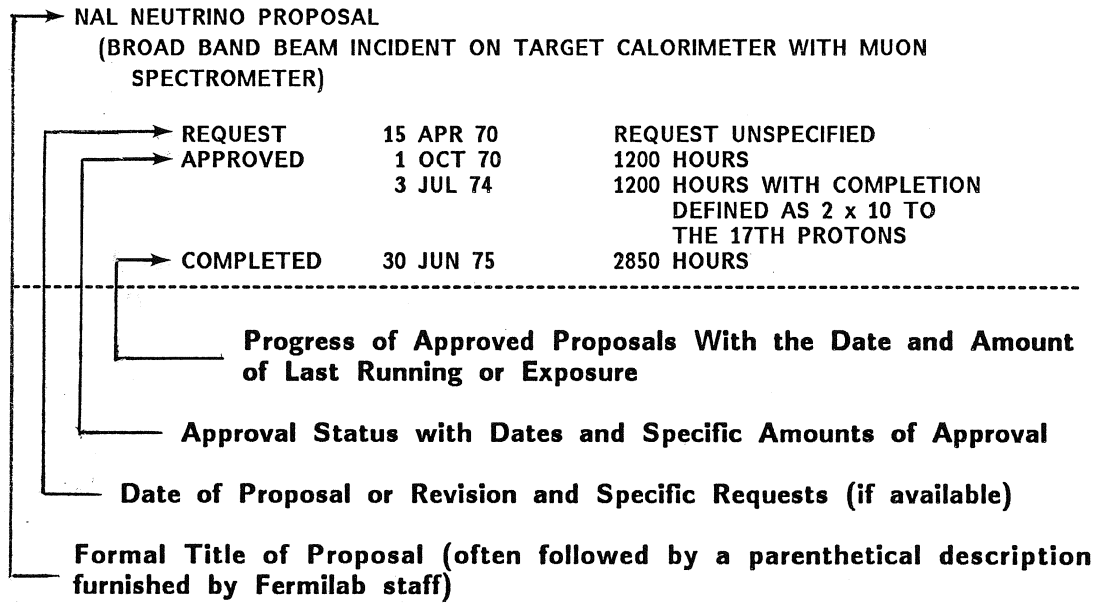
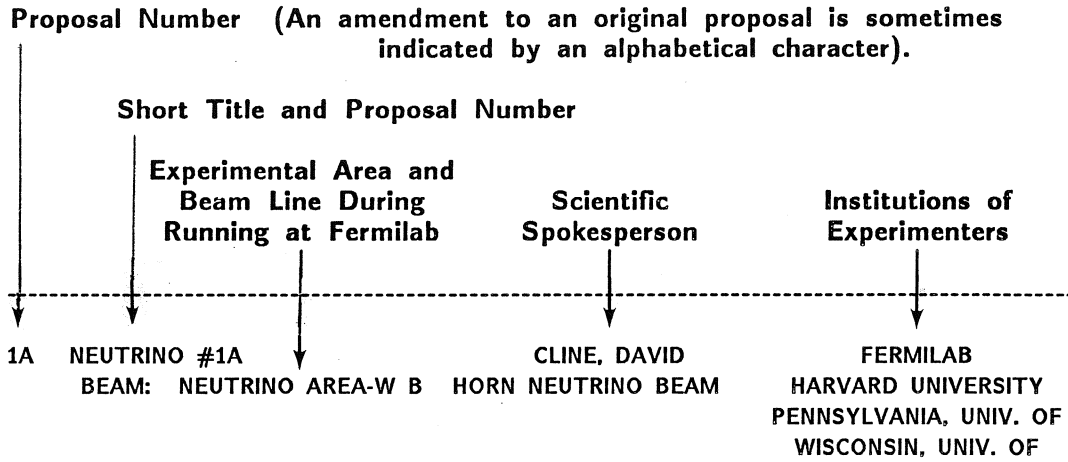

Note: For proposals having a number below 700, only the approved proposals are listed.
Total number of proposals - 965 ... Total number of approved & pending proposals - 487

1A	NEUTRINO #1A	David B. Cline	FERMILAB HARVARD UNIVERSITY UNIVERSITY OF PENNSYLVANIA UNIVERSITY OF WISCONSIN - MADISON
	BEAM: Neutrino Area - Wide Band Horn NAL NEUTRINO PROPOSAL. (Broad band beam incident on target calorimeter with muon spectrometer.)		
	Request	15 Apr, 70 Unspecified	
	Approval	1 Oct, 70 1,200 Hours	
	Completed	3 Jul, 74 1,200 Hours with completion of the experiment defined as 20,000 events with 2 x 10 to the 17th protons on a horn-focused beam	
2B	30-INCH HYBRID #2B	Gerald A. Smith	DUKE UNIVERSITY FERMILAB IOWA STATE UNIVERSITY UNIVERSITY OF MARYLAND MICHIGAN STATE UNIVERSITY NOTRE DAME UNIVERSITY PURDUE UNIVERSITY UNIVERSITY OF TORONTO (CANADA) UNIVERSITY OF WISCONSIN - MADISON
	BEAM: Neutrino Area - 30 in. Hadron Beam STUDY OF MULTIPARTICLE P-P AND PI-P INTERACTIONS FROM 100 GEV/C TO 400 GEV/C WITH A 30-INCH BUBBLE CHAMBER-OPTICAL SPARK CHAMBER HYBRID SYSTEM.		
	Request	11 May, 70 Unspecified but to include an exposure for study of p - p and pi - p interactions from 75 to 300 GeV	
	Approval	29 Apr, 71 500 K Pix 1 May, 71 450 K Pix	ANL/Fermilab, MSU, ISU, MD Duke, Toronto, Notre Dame Purdue, Wisconsin
	Completed	22 Apr, 74 479 K Pix	
	100K pix of p - p @ 200 GeV 100K pix of p - p @ 300 GeV 120K pix of pi minus - p @ 200 GeV 50K pix of pi minus - p @ 100 GeV 80K pix of pi plus - p @ 100 GeV 114K pix of p - p @ 200 105K pix of p - p @ 300 123K pix of pi - p @ 200 54K pix of pi - p @ 100 83K pix of pi+ - p @ 100 bonus pix: 350K pix from #37A, #121A, #125, #137, #138, #141A, #143, #252		
3	MONOPOLE #3	Philippe Eberhard	LAWRENCE BERKELEY LABORATORY
	BEAM: Neutrino Area - Miscellaneous PROPOSAL FOR A SEARCH FOR MAGNETIC MONOPOLES AT NAL. (Ferromagnetic target located in a beam dump.)		
	Request	20 May, 70 Target Exposure(s) to 1 x 10 to 18th protons	
	Approval	1 Aug, 70 Target Exposure(s)	
	Completed	4 Sep, 74 4 Targets Exposed	
4	NEUTRON CROSS SECTION #4	Michael J. Longo	LAWRENCE BERKELEY LABORATORY UNIVERSITY OF MICHIGAN - ANN ARBOR
	BEAM: Meson Area - M3 Beam NEUTRON TOTAL CROSS SECTIONS UP TO 300 GEV. (Total cross sections on H2, D2, heavy nuclei to < 2%.)		
	Request	20 May, 70 300 Hours with 100 hours for tune up and 200 hours for data to measure total cross sections	
	Approval	1 Aug, 70 400 Hours	
	Completed	20 Mar, 74 1,450 Hours	
7	ELASTIC SCATTERING #7	Donald I. Meyer	ARGONNE NATIONAL LABORATORY FERMILAB INDIANA UNIVERSITY UNIVERSITY OF MICHIGAN - ANN ARBOR
	BEAM: Meson Area - M1 Beam PROPOSAL TO MEASURE PI+(+) - P AND P-P DIFFERENTIAL ELASTIC SCATTERING CROSS SECTIONS FROM 50 TO 170 GEV/C. (In addition, data will be taken on K+(+) - p and pbar - p simultaneously; t from 0.1 - 2.0 or 3.0.)		
	Request	10 Jun, 70 1,600 Hours	
	Approval	1 Aug, 70 800 Hours	
	Completed	28 Jan, 75 2,350 Hours	
8	NEUTRAL HYPERON #8	Lee G. Pondrom	UNIVERSITY OF MICHIGAN - ANN ARBOR RUTGERS UNIVERSITY UNIVERSITY OF WISCONSIN - MADISON
	BEAM: Meson Area - M2 Beam EXPERIMENTS IN A NEUTRAL HYPERON BEAM. (Beam survey, delta s = 2 decay search, and lambda - p scattering.)		
	Request	12 Jun, 70 260 Hours for data	
	Approval	1 Aug, 70 400 Hours	
	Completed	22 Mar, 76 2,450 Hours	
12	NEUTRON BACKWARD SCATTERING #12	Neville W. Ray	CARLTON UNIVERSITY (CANADA) MICHIGAN STATE UNIVERSITY OHIO STATE UNIVERSITY
	BEAM: Meson Area - M3 Beam A STUDY OF NEUTRON-PROTON CHARGE-EXCHANGE SCATTERING IN THE MOMENTUM RANGE 50-300 GEV/C. (u from 0.002 - 1.0.)		
	Request	15 Jun, 70 760 Hours	
	Approval	1 Aug, 70 600 Hours with priority lower than exp #4	
	Completed	2 Dec, 74 1,300 Hours	
14A	PROTON-PROTON INELASTIC #14A	Paolo Franzini	COLUMBIA UNIVERSITY SUNY AT STONY BROOK
	BEAM: Neutrino Area - Miscellaneous PROPOSAL TO STUDY INELASTIC HIGH-ENERGY PROTON-PROTON COLLISIONS IN THE DIFFRACTIVE REGION. (t from 0.001 - 0.07 and missing mass to 10 GeV.)		
	Request	15 Jun, 70 200 Hours	
	Approval	1 Mar, 71 150 Hours with low priority	
	Completed	21 Jun, 73 140 Hours	

21A	NEUTRINO #21A BEAM: Neutrino Area - Dichromatic NEUTRINO PHYSICS AT VERY HIGH ENERGIES. (Dichromatic beam incident on target calorimeter with muon spectrometer.)	Barry C. Barish	CALIFORNIA INSTITUTE OF TECHNOLOGY FERMILAB
	Request	15 Jun, 70	750 Hours
	Approval	1 Aug, 70	1,200 Hours
		26 Jun, 74	1,200 Hours with the inclination for the completion of exp# 21A (approximately 400 hours) to have a lower priority than running for exp# 320
	Completed	11 Nov, 74	1,200 Hours with remaining running to be coordinated with exp# 254
		2 Nov, 75	2,450 Hours
22	MULTIGAMMA #22 BEAM: Meson Area - M2 Beam EXPERIMENTAL PROPOSAL TO THE NATIONAL ACCELERATOR LABORATORY FOR A SEARCH FOR MULTIGAMMA EVENTS FROM MAGNETIC MONOPOLE PAIRS.	George B. Collins	BROOKHAVEN NATIONAL LABORATORY VIRGINIA TECH.
	Request	15 Jun, 70	100 Hours for data
	Approval	1 Aug, 70	200 Hours for hadron beam use only
	Completed	26 Jun, 74	350 Hours
25A	PHOTON TOTAL CROSS SECTION #25A BEAM: Proton Area - East MEASUREMENT OF THE TOTAL PHOTOABSORPTION CROSS SECTION ON H, D, C, CU, AND PB FOR PHOTON ENERGIES FROM 14 TO 300 GEV, AND A SEARCH FOR THE PHOTOPRODUCED MONOPOLE.	David O. Caldwell	UNIV. OF CALIFORNIA, SANTA BARBARA FERMILAB LEBEDEV PHYSICAL INST. (RUSSIA) UNIVERSITY OF TORONTO (CANADA)
	Request	15 Jun, 70	400 Hours for data
	Approval	1 Aug, 71	600 Hours with 200 hours for tuning, 400 hours for data
		26 Oct, 76	1,000 Hours with additional 400 hours for the experiment to continue data taking until 30 Nov 1976
	Completed	30 Nov, 76	1,850 Hours
26	MUON #26 BEAM: Neutrino Area - Muon/Hadron Beam HIGH MOMENTUM TRANSFER INELASTIC MUON SCATTERING AND TEST OF SCALE INVARIANCE AT NAL.	Louis N. Hand	UNIV. OF CALIFORNIA, SAN DIEGO CORNELL UNIVERSITY LAWRENCE BERKELEY LABORATORY MICHIGAN STATE UNIVERSITY
	Request	15 Jun, 70	Unspecified
	Approval	1 Aug, 70	500 Hours
		6 Aug, 73	500 Hours defined as 3 x 10 to the 17th protons
	Completed	16 Apr, 74	900 Hours
27A	NEUTRON DISSOCIATION #27A BEAM: Meson Area - M3 Beam PROPOSAL TO STUDY THE COHERENT DISSOCIATION OF NEUTRONS.	Jerome L. Rosen	FERMILAB UNIVERSITY OF MASSACHUSETTS NORTHWESTERN UNIVERSITY UNIVERSITY OF ROCHESTER
	Request	15 Jun, 70	Unspecified
	Approval	1 Mar, 71	200 Hours for low priority Stage I running
	Completed	24 Apr, 74	850 Hours
28A	15-FOOT NEUTRINO/H2&NE #28A BEAM: Neutrino Area - Wide Band Horn SEARCH FOR HEAVY LEPTONS AND HARD PENETRATING RADIATION IN THE NEUTRINO BEAM; STUDY DIFFRACTION SCATTERING OF NEUTRINOS AND DEEP INELASTIC MUON-NEUTRINO SCATTERING IN A NEON BUBBLE CHAMBER AT NAL; TEST OF DELTA S-DELTA Q RULE @ HIGH MOMENTUM	William F. Fry	CERN (SWITZERLAND) UNIVERSITY OF HAWAII AT MANOA LAWRENCE BERKELEY LABORATORY UNIVERSITY OF WISCONSIN - MADISON
	Request	15 Jun, 70	1,000 K Pix to include 500K pix with the primary protons incident on the hadron shield and 500K pix with normal targetry
	Approval	1 Dec, 71	100 K Pix with 50K pix of neutrinos in neon (greater than or equal to 30%) with the constraint that running conditions yield at least 10,000 events; and 50K pix of neutrinos using special targeting
		9 May, 75	100 K Pix total of neutrinos in the 22% neon mixture under horn focusing conditions
	Completed	11 Jun, 75	97 K Pix
31A	15-FOOT ANTI-NEUTRINO/H2 #31A BEAM: Neutrino Area - Wide Band Horn PROPOSAL TO INVESTIGATE MUON-ANTINEUTRINO INTERACTIONS IN HYDROGEN AT NAL.	Malcolm Derrick	ARGONNE NATIONAL LABORATORY CARNEGIE-MELLON UNIVERSITY PURDUE UNIVERSITY
	Request	15 Jun, 70	1,000 K Pix requiring a total exposure of 10 to the 19th protons with 10 to the 13th protons per pulse on target
	Approval	1 Dec, 71	200 K Pix maximum with the constraint that the running conditions yield at least 7,000 antineutrino interactions
	Completed	13 Aug, 77	211 K Pix
34	DETECTOR DEVELOPMENT #34 BEAM: Neutrino Area - Miscellaneous NUCLEAR-ELECTROMAGNETIC CASCADE DEVELOPMENT STUDY. (Ionization spectrometer development.)	Richard W. Huggett	LOUISIANA STATE UNIVERSITY MAX-PLANCK INSTITUTE (GERMANY)
	Request	15 Jun, 70	400 Hours in two calibration runs
	Approval	1 Aug, 70	Parasitic Running
	Completed	26 Jun, 74	50 Hours
36A	PROTON-PROTON SCATTERING #36A BEAM: Internal Target Area (C-0) A PROPOSAL TO STUDY SMALL ANGLE P-P SCATTERING AT VERY HIGH ENERGIES. (Using a gas jet target and the internal proton beam.)	Rodney L. Cool	FERMILAB JINR, DUBNA (RUSSIA) UNIVERSITY OF ROCHESTER ROCKEFELLER UNIVERSITY
	Request	15 Jun, 70	550 Hours
	Approval	1 Feb, 71	500 Hours
	Completed	24 Jun, 73	700 Hours

37A	30-INCH P-P @ 300 #37A	Ernest I. Malamud	CALIFORNIA INSTITUTE OF TECHNOLOGY UNIV. OF CALIFORNIA, LOS ANGELES FERMILAB INDIANA UNIVERSITY
	BEAM: Neutrino Area - 30 in. Hadron Beam MULTIBODY FINAL STATES IN PP COLLISIONS UP TO 500 GEV.		
	+-----+		
	Request	15 Jun, 70	250 K Pix of p - p interactions at 100,200,300,400,500 GeV in 15-foot chamber
		3 May, 71	100 K Pix of p - p interactions at one fixed high energy in 30-inch chamber
	Approval	26 Aug, 71	50 K Pix in bare chamber with events where there is downstream spark chamber data to be shared with exp #2B
	Completed	1 Jun, 73	51 K Pix
45A	15-FOOT NEUTRINO/H2 #45A	Frank A. Nezirick	FERMILAB UNIVERSITY OF HAWAII AT MANOA LAWRENCE BERKELEY LABORATORY UNIVERSITY OF MICHIGAN - ANN ARBOR
	BEAM: Neutrino Area - Wide Band Horn PROPOSAL TO STUDY NEUTRINO INTERACTIONS WITH PROTONS USING THE 15-FOOT BUBBLE CHAMBER AT NAL.		
	+-----+		
	Request	15 Jun, 70	200 K Pix with 10 to the 13th protons/pulse of at least 200 GeV
		19 Jul, 71	500 K Pix with 10 to the 13th protons/pulse at 350 GeV
	Approval	17 Dec, 71	300 K Pix maximum with the constraint that the running conditions yield on the order of 15,000 events of neutrinos in hydrogen
	Completed	13 Jan, 76	162 K Pix
48	MUON SEARCH #48	Robert K. Adair	BROOKHAVEN NATIONAL LABORATORY FERMILAB YALE UNIVERSITY
	BEAM: Proton Area - Center A MEASUREMENT OF THE INTENSITY AND POLARIZATION OF MUONS PRODUCED DIRECTLY BY THE INTERACTIONS OF PROTONS WITH NUCLEI.		
	+-----+		
	Request	15 Jun, 70	200 Hours
	Approval	1 Dec, 70	200 Hours for an exploratory experiment
	Completed	1 Dec, 75	500 Hours
51A	MISSING MASS #51A	Eberhard Von Goeler	NORTHEASTERN UNIVERSITY
	BEAM: Meson Area - M2 Beam MASS SPECTRA AND DECAY MODES FOR HADRONS WITH MASSES UP TO 15 GEV.		
	+-----+		
	Request	15 Jun, 70	850 Hours
	Approval	14 Aug, 73	300 Hours with low priority
	Completed	23 Oct, 74	800 Hours
53A	15-FOOT NEUTRINO/H2&NE #53A	Charles Baltay	BROOKHAVEN NATIONAL LABORATORY COLUMBIA UNIVERSITY
	BEAM: Neutrino Area - Wide Band Horn SEARCH FOR THE INTERMEDIATE BOSON, LEPTON PAIR PRODUCTION, AND A STUDY OF DEEPLY INELASTIC REACTIONS UTILIZING HIGH ENERGY NEUTRINO INTERACTIONS IN LIQUID NEON.		
	+-----+		
	Request	15 Jun, 70	1,000 K Pix of neutrino interactions in 15-foot with 70% neon and 30% deuterium and with inserted plate
		6 Jul, 71	1,000 K Pix with 900K pix of neutrino interactions in neon with single plate and 100K pix in hydrogen with two plates
		16 Jun, 76	200 K Pix requested increase of the approved picture total from 100K to 200K
		25 Jan, 78	450 K Pix to include an increase of 300K beyond the approximately 150K pix presently available for the experiment; at least 150K pix additional are requested during the summer or fall of 1978
	Approval	19 Jun, 78	450 K Pix to include an increase of 300K pix; this follows rejection of the
		17 Dec, 71	100 K Pix in neon or plates to yield at least 20,000 events total including
		29 Jun, 76	150 K Pix total including about 50K pix already taken
		28 Jun, 78	450 K Pix total including an extension for 300K pix
	Completed	9 Mar, 81	440 K Pix
61	POLARIZED SCATTERING #61	Owen Chamberlain	ARGONNE NATIONAL LABORATORY FERMILAB HARVARD UNIVERSITY LAWRENCE BERKELEY LABORATORY SUFFOLK UNIVERSITY YALE UNIVERSITY
	BEAM: Meson Area - M1 Beam A PROPOSAL TO MEASURE POLARIZATION IN P P, PI- P, AND PI+ P ELASTIC SCATTERING AT 50, 100, AND 150 GEV/C.		
	+-----+		
	Request	15 Jun, 70	1,100 Hours for setup, tests, and data
		10 Mar, 77	1,600 Hours to include additional time for 4 weeks of data at 300 GeV and 1 week at 100 GeV; running requires accelerator operation at those energies
	Approval	1 Aug, 70	800 Hours
		24 Jun, 77	1,200 Hours with an attempt to provide 300 GeV data under the condition that the running not interfere with other major laboratory programs
	Completed	26 Oct, 77	1,900 Hours
63A	PHOTON SEARCH #63A	James K. Walker	FERMILAB UNIVERSITY OF HAWAII AT MANOA NORTHERN ILLINOIS UNIVERSITY
	BEAM: Internal Target Area (C-0) SURVEY OF PARTICLE PRODUCTION IN PROTON COLLISIONS AT NAL. (Photon production in proton collisions at the Internal Target Area; see also exp #284.)		
	+-----+		
	Request	15 Jun, 70	Unspecified
	Approval	17 Dec, 70	400 Hours
		19 Oct, 73	400 Hours with understanding that additional photon production data would be taken at 60, 50, 40, 30, and 20 mrad
	Completed	13 Mar, 75	2,600 Hours
67A	PROTON-PROTON MISSING MASS #67A	Felix Sannes	FLORIDA STATE UNIVERSITY RUTGERS UNIVERSITY UPSALA COLLEGE
	BEAM: Internal Target Area (C-0) SEARCH FOR BARYON RESONANCES UP TO 10 GEV MASS PRODUCED IN P + P TO P + MM WITH A RESOLUTION OF + OR - 25 MEV. (Using a gas jet target and the internal proton beam.)		
	+-----+		
	Request	15 Jun, 70	Unspecified
	Approval	1 Feb, 71	100 Hours
	Completed	8 Aug, 73	600 Hours

69A	ELASTIC SCATTERING #69A BEAM: Meson Area - M6 Beam ELASTIC SCATTERING OF THE LONG-LIVED HADRONS. (Small angle scattering to t of 0.2 and coulomb interference.)	Joseph Lach	FERMILAB RUTHERFORD-APPLETON LABS. (ENGLAND) YALE UNIVERSITY
	Request	15 Jun, 70	380 Hours of 'ideal time' to make coulomb interference measurements with stable particles and diffraction peak measurements with hyperons
		1 Dec, 70	180 Hours of 'ideal time' to make coulomb interference measurements with stable particles; also see exp# 97 and 497
	Approval	15 Sep, 70	600 Hours
	Completed	3 Mar, 76	2,800 Hours
70	LEPTON #70 BEAM: Proton Area - Center STUDY OF LEPTON PAIRS FROM PROTON-NUCLEAR INTERACTIONS; SEARCH FOR INTERMEDIATE BOSONS AND LEE-WICK STRUCTURE.	Leon M. Lederman	COLUMBIA UNIVERSITY FERMILAB
	Request	23 Jun, 70	2,800 Hours to include about 1,700 hours for study of single lepton production and 1,100 hours for study of lepton pairs
	Approval	1 Dec, 70	600 Hours
	Completed	1 Dec, 74	2,800 Hours
72	QUARK #72 BEAM: Meson Area - M4 Beam EXPERIMENTAL PROPOSAL TO NAL -- QUARK SEARCH. (By measuring ionization energy loss.)	Lawrence B. Leipuner	BROOKHAVEN NATIONAL LABORATORY YALE UNIVERSITY
	Request	15 Jun, 70	100 Hours for data taking
	Approval	1 Aug, 70	200 Hours
	Completed	11 Jun, 73	500 Hours
75	QUARK #75 BEAM: Meson Area - M2 Beam A PROPOSAL TO SEARCH FOR FRACTIONALLY CHARGED QUARKS. (Measurement of ionization and total energy of fractionally charged particles using momentum selection.)	Taiji Yamanouchi	FERMILAB NEW YORK UNIVERSITY
	Request	29 Jun, 70	200 Hours for tests and data taking
	Approval	1 Sep, 70	200 Hours
	Completed	8 Sep, 73	1,050 Hours
76	MONOPOLE #76 BEAM: Neutrino Area - Miscellaneous SEARCH FOR MAGNETIC MONOPOLES PRODUCED AT NAL. (Employing a beam-dump target.)	Richard A. Carrigan	FERMILAB
	Request	15 Jun, 70	Parasitic Running
	Approval	1 Sep, 70	Target Exposure(s) with parasitic running
	Completed	1 Dec, 74	5 Targets Exposed
81A	NUCLEAR CHEMISTRY #81A BEAM: Meson Area - Miscellaneous PRELIMINARY SURVEY OF 200 GEV PROTON INTERACTIONS WITH COMPLEX NUCLEI. (Nuclear chemistry analysis.)	Sheldon Kaufman	ARGONNE NATIONAL LABORATORY BROOKHAVEN NATIONAL LABORATORY CARNEGIE-MELLON UNIVERSITY UNIVERSITY OF CHICAGO UNIV. OF ILLINOIS, CHICAGO CIRCLE PURDUE UNIVERSITY RBL, ORSAY (FRANCE)
	Request	9 Jul, 70	Parasitic Running
	Approval	1 Aug, 70	Target Exposure(s)
	Completed	1 Oct, 78	197 Bombardment(s)
82	K ZERO REGENERATION #82 BEAM: Meson Area - M4 Beam PROPOSAL TO INVESTIGATE REGENERATION OF NEUTRAL K-MESONS AT VERY HIGH ENERGIES. (See exp #425.)	Valentine L. Telegdi	UNIV. OF CALIFORNIA, SAN DIEGO UNIVERSITY OF CHICAGO SLAC UNIVERSITY OF WISCONSIN - MADISON
	Request	13 Jul, 70	1,000 Hours for preliminary run and data taking
	Approval	15 Sep, 70	800 Hours
		22 Nov, 74	1,100 Hours total including additional 300 hours with complex nuclear targets
	Completed	5 Jul, 75	3,500 Hours
86A	PION DISSOCIATION #86A BEAM: Meson Area - M1 Beam A PROPOSAL TO STUDY INELASTIC DIFFRACTIVE PROCESSES BY OBSERVING COHERENT PRODUCTION OF MULTI-PION FINAL STATES FROM HE NUCLEI. (Using a streamer chamber.)	Henry J. Lubatti	LAL, ORSAY (FRANCE) UNIVERSITY OF WASHINGTON
	Request	24 Jul, 70	1,050 Hours for setup, tests and data taking
	Approval	28 May, 71	800 Hours with low priority
	Completed	22 Mar, 76	800 Hours
87A	PHOTOPRODUCTION #87A BEAM: Proton Area - East PROPOSAL TO SEARCH FOR HEAVY LEPTONS AND INTERMEDIATE BOSONS FROM PHOTON-NUCLEON AND PHOTON-NUCLEI COLLISIONS.	Thomas A. O'Halloran, Jr.	COLUMBIA UNIVERSITY FERMILAB UNIVERSITY OF HAWAII AT MANOA UNIVERSITY OF ILLINOIS, CHAMPAIGN
	Request	30 Jul, 70	Unspecified
		25 Feb, 71	4,400 Hours for setup, tests, and data taking
	Approval	1 Aug, 71	600 Hours
		13 Nov, 75	1,100 Hours with an extension of 500 hours of data taking
		28 Jul, 77	3,100 Hours with an additional 2,000 hours for study of charmed baryon production
	Completed	7 May, 78	4,800 Hours
90	EMULSION/PROTONS @ 200 #90 BEAM: Meson Area - Miscellaneous CRACOW NUCLEAR EMULSION EXPOSURES.	Wladyslaw Wolter	INP, KRAKOW (POLAND)
	Request	23 Jun, 70	Emulsion Exposure
	Approval	1 Aug, 70	Emulsion Exposure
	Completed	20 Sep, 72	4 Stack(s)

95A	PHOTON SEARCH #95A BEAM: Proton Area - West PROPOSAL FOR EXAMINATION OF WIDE ANGLE GAMMA RAYS AT NAL. (Single and digamma production by proton-nucleon collisions.)	Bradley B. Cox	FERMILAB JOHNS HOPKINS UNIVERSITY
	Request	26 Oct, 70	100 Hours of data taking with parasitic beam used for setup
		12 Oct, 76	3,100 Hours for further study of diphoton spectra
	Approval	1 Jun, 71	400 Hours
		5 Jan, 77	1,650 Hours with an extension in an effort to approach the 12.5 weeks of running which was requested
	Completed	12 Sep, 77	1,950 Hours with approval of an additional 3 weeks of running at 200/300 GeV
		17 Oct, 77	3,400 Hours
96	ELASTIC SCATTERING #96 BEAM: Meson Area - M6 Beam FOCUSING SPECTROMETER FACILITY. (Measure elastic scattering and quasi elastic scattering of pi+(-), K+(-), p+(-) on H2 and D2 up to 200 GeV/c with t up to 1.5.)	David Ritson	ARGONNE NATIONAL LABORATORY UNIVERSITY OF BARI (ITALY) BROWN UNIVERSITY CERN (SWITZERLAND) CORNELL UNIVERSITY FERMILAB MASSACHUSETTS INST. OF TECHNOLOGY NORTHEASTERN UNIVERSITY STANFORD UNIVERSITY
	Request	3 Dec, 70	1,000 Hours for check out and data taking
	Approval	1 Dec, 70	800 Hours
	Completed	17 Feb, 75	2,550 Hours
98	MUON #98 BEAM: Neutrino Area - Muon/Hadron Beam MUON-PROTON INELASTIC SCATTERING EXPERIMENT AT THE NATIONAL ACCELERATOR LABORATORY. (Using a large aperture magnet to detect scattered muons and charged hadrons.)	Herbert L. Anderson	UNIVERSITY OF CHICAGO HARVARD UNIVERSITY UNIVERSITY OF ILLINOIS, CHAMPAIGN UNIVERSITY OF OXFORD (ENGLAND)
	Request	2 Dec, 70	1,600 Hours for tests and data taking
	Approval	19 Jan, 71	400 Hours of initial running with H2 (100 hours of parasitic testing)
		6 Aug, 73	400 Hours with approval for both D2 and H2
		26 Jun, 74	800 Hours with additional 400 hours for data taking
	Completed	17 Feb, 75	1,800 Hours
99	ASSOCIATED PRODUCTION #99 BEAM: Meson Area - M6 Beam A STUDY OF PI+ P TO K+ SIGMA+ AND PI+ P TO K+ Y-STAR+ USING THE FOCUSING SPECTROMETER FACILITY. (Incident momenta from 20 - 120 GeV/c, t from 0.04 - 0.6.)	Robert E. Diebold	ARGONNE NATIONAL LABORATORY FERMILAB SLAC STANFORD UNIVERSITY
	Request	3 Dec, 70	500 Hours for tests and data taking
	Approval	25 Nov, 74	500 Hours
	Completed	24 Jan, 78	750 Hours
100A	PARTICLE SEARCH #100A BEAM: Proton Area - East A PROPOSAL TO STUDY PARTICLE PRODUCTION AT HIGH TRANSVERSE MOMENTA. (Measurement of particle production at 90 degrees in c.m. from proton interactions with nuclei.)	Pierre A. Piroué	UNIVERSITY OF CHICAGO PRINCETON UNIVERSITY
	Request	4 Dec, 70	500 Hours for data taking
	Approval	1 Feb, 71	500 Hours
	Completed	4 Apr, 74	1,150 Hours
103	EMULSION/PROTONS @ 200 #103 BEAM: Meson Area - Miscellaneous INTRA-NUCLEAR CASCADE PRODUCED BY 200 GEV PROTONS.	David T. King	UNIVERSITY OF TENNESSEE, KNOXVILLE
	Request	21 Dec, 70	Emulsion Exposure
	Approval	1 Feb, 71	Emulsion Exposure
	Completed	20 Sep, 72	1 Stack(s)
104	TOTAL CROSS SECTION #104 BEAM: Meson Area - M1 Beam MEASUREMENT OF TOTAL CROSS SECTIONS ON HYDROGEN AND DEUTERIUM. (Of pi+, K+, p, pbar.)	Thaddeus F. Kycia	BROOKHAVEN NATIONAL LABORATORY FERMILAB MAX-PLANCK INSTITUTE (GERMANY) ROCKEFELLER UNIVERSITY UNIVERSITY OF WASHINGTON
	Request	8 Jan, 71	700 Hours for tests and data taking
		16 Jun, 76	1,300 Hours total with additional 600 hours for completion of cross section data and particle search exp# 354
	Approval	8 Mar, 71	700 Hours
		29 Jun, 76	1,300 Hours including an additional 600 hours for the remainder of exp# 104 and exp# 354
	Completed	22 Dec, 77	2,650 Hours
105	EMULSION/PROTONS @ 200 #105 BEAM: Meson Area - Miscellaneous A PROPOSAL TO STUDY SOME CHARACTERISTICS OF PROTON-NUCLEON AND PROTON-NUCLEUS COLLISIONS AT 400 GEV USING NUCLEAR EMULSIONS.	Prince K. Malhotra	JAMMU UNIVERSITY (INDIA) PANJAB UNIVERSITY (INDIA) TATA INSTITUTE (INDIA)
	Request	14 Jan, 71	Emulsion Exposure
	Approval	1 Apr, 71	Emulsion Exposure
	Completed	20 Sep, 72	1 Stack(s)
108	BEAM DUMP #108 BEAM: Meson Area - M2 Beam A BEAM DUMP EXPERIMENT. (Study of shielding including hadron cascade development, muon attenuation, radioactivity.)	Miguel Awschalom	FERMILAB
	Request	4 Feb, 71	40 Hours for irradiation
	Approval	1 Mar, 71	40 Hours
	Completed	2 Jun, 75	350 Hours

110A	MULTIPARTICLE #110A BEAM: Meson Area - M6 Beam PROPOSAL TO STUDY MULTIPARTICLE PERIPHERAL PHYSICS AT NAL. (Using a large wire chamber magnetic spectrometer.)	Alexander R. Dzierba	CALIFORNIA INSTITUTE OF TECHNOLOGY UNIV. OF CALIFORNIA, LOS ANGELES FERMILAB UNIV. OF ILLINOIS, CHICAGO CIRCLE INDIANA UNIVERSITY MAX-PLANCK INSTITUTE (GERMANY)
	Request	15 Feb, 71 400 Hours for test run and overview 10 Aug, 72 900 Hours for tests and data taking 21 Oct, 76 900 Hours for data taking	
	Approval	5 Apr, 72 800 Hours 16 Nov, 73 600 Hours with understanding that approximately 200 hours of previously approved 800 hours of running will be used for exp# 260 18 Nov, 76 1,000 Hours with expectation that 800 hours will be used for data taking and 2 weeks for tuneup of beam and equipment	
	Completed	9 Apr, 78 1,600 Hours	
111	PION CHARGE EXCHANGE #111 BEAM: Meson Area - M2 Beam PROPOSAL TO STUDY PI- P TO PION AND PI- P TO ETAN AT HIGH ENERGY.	Alvin V. Tollestrup	CALIFORNIA INSTITUTE OF TECHNOLOGY LAWRENCE BERKELEY LABORATORY
	Request	15 Feb, 71 450 Hours for tests and data taking	
	Approval	1 Feb, 71 400 Hours	
	Completed	19 Sep, 74 1,800 Hours	
114	EMULSION/PROTONS @ 200 #114 BEAM: Meson Area - Miscellaneous STUDY OF 200-500 GEV PROTON AND PION INTERACTION WITH NUCLEAR EMULSION.	Piyare L. Jain	SUNY AT BUFFALO
	Request	24 Feb, 71 Emulsion Exposure	
	Approval	1 Mar, 72 Emulsion Exposure	
	Completed	20 Sep, 72 1 Stack(s)	
115	LONG-LIVED PARTICLES #115 BEAM: Neutrino Area - Miscellaneous SEARCH FOR LONG-LIVED PARTICLES (Tau greater than or approximately equal 0.1 msec; analysis of particles from a beam dump.)	M. Lynn Stevenson	LAWRENCE BERKELEY LABORATORY
	Request	1 Mar, 71 Parasitic Running	
	Approval	26 Aug, 71 Parasitic Running	
	Completed	23 Nov, 74 6 Hours	
116	EMULSION/PROTONS @ 200 #116 BEAM: Meson Area - Miscellaneous INTERACTION OF HIGH ENERGY PROTONS IN NUCLEAR EMULSIONS LOADED WITH B 10 AND LIF.	Jacques D. Hebert	UNIVERSITY OF BARCELONA (SPAIN) CRN, STRASBOURG (FRANCE) FERMILAB UNIVERSITY OF LYON (FRANCE) MCGILL UNIVERSITY (CANADA) UNIVERSITY OF MONTREAL (CANADA) UNIVERSITY OF OTTAWA (CANADA) UNIVERSITY OF VALENCIA (SPAIN)
	Request	31 Mar, 71 Emulsion Exposure	
	Approval	1 Apr, 71 Emulsion Exposure	
	Completed	20 Sep, 72 5 Stack(s)	
117A	EMULSION/PROTONS @ 200 #117A BEAM: Meson Area - Miscellaneous PHENOMOLOGICAL STUDY OF 200 AND 500 GEV/C PROTON-PROTON COLLISIONS IN EMULSION.	Osamu Kusumoto	KINKI UNIVERSITY (JAPAN) KOBE UNIVERSITY (JAPAN) OSAKA CITY UNIVERSITY (JAPAN) OSAKA SCIENCE EDUC. INST. (JAPAN) WAKAYAMA MEDICAL COLLEGE (JAPAN)
	Request	2 Mar, 71 Emulsion Exposure	
	Approval	1 Apr, 71 Emulsion Exposure	
	Completed	20 Sep, 72 11 Stack(s)	
118A	INCLUSIVE SCATTERING #118A BEAM: Meson Area - M6 Beam HADRON SPECTRA FROM HIGH ENERGY INTERACTIONS. (Single particle inclusive spectra from pions, kaons, and protons using single arm spectrometer.)	George W. Brandenburg	UNIVERSITY OF BARI (ITALY) BROWN UNIVERSITY FERMILAB MASSACHUSETTS INST. OF TECHNOLOGY
	Request	3 Mar, 71 950 Hours for tests and data taking 20 Jun, 73 1,200 Hours total with additional 250 hours of data taking 22 Oct, 76 950 Hours with an additional 350 hours to extend existing measurements; see proposal #513	
	Approval	25 Nov, 74 600 Hours 18 Nov, 76 950 Hours with additional 350 hours for continued data taking	
	Completed	20 Jul, 77 2,550 Hours	
120	PHOTON SEARCH #120 BEAM: Internal Target Area (C-0) EARLY PI ZERO PARTICLE PRODUCTION SURVEY WITH THE GAS JET TARGET. (Also direct photon production using the internal proton beam.)	David B. Cline	UNIVERSITY OF CHICAGO HARVARD UNIVERSITY UNIVERSITY OF WISCONSIN - MADISON
	Request	9 Mar, 71 Unspecified	
	Approval	1 Jun, 71 200 Hours	
	Completed	29 May, 73 1,200 Hours	
121A	30-INCH PI+ & P - P @ 100 #121A BEAM: Neutrino Area - 30 in. Hadron Beam A PROPOSAL TO SEARCH FOR VERY HEAVY STRANGE PARTICLES USING A SMALL HYDROGEN BUBBLE CHAMBER.	Richard L. Lander	UNIV. OF CALIFORNIA, DAVIS LAWRENCE BERKELEY LABORATORY
	Request	11 Mar, 71 100 K Pix 17 May, 71 200 K Pix total with 50K at each of four incident proton momenta, 100, 200, 300, and 400 GeV/c	
	Approval	26 Aug, 71 50 K Pix in bare chamber with events where there is downstream spark chamber data to be shared with exp #2B	
	Completed	23 Jan, 74 104 K Pix	
125	30-INCH PI- - P @ 100 #125 BEAM: Neutrino Area - 30 in. Hadron Beam PROPOSAL TO STUDY PI- P REACTIONS AT 60 AND 200 GEV/C IN THE 30-INCH.	Douglas R. O. Morrison	CERN (SWITZERLAND)
	Request	7 May, 71 100 K Pix	
	Approval	27 Aug, 71 50 K Pix in bare chamber with events where there is downstream spark chamber data to be shared with exp #2B	
	Completed	28 Aug, 73 53 K Pix	

137	30-INCH PI- - P @ 200 #137	Fred Russell Huson	UNIV. OF CALIFORNIA, BERKELEY FERMILAB LAWRENCE BERKELEY LABORATORY
	BEAM: Neutrino Area - 30 in. Hadron Beam		
	STUDY OF PI- + P INTERACTIONS AT HIGH ENERGY.		
	+-----+		
	Request	4 May, 71	50 K Pix
	Approval	26 Aug, 71	50 K Pix in bare chamber with events where there is downstream spark chamber data to be shared with exp #2B
	Completed	10 Mar, 73	48 K Pix
138	30-INCH P-P @ 400 #138	Jack C. Vander Velde	UNIVERSITY OF MICHIGAN - ANN ARBOR UNIVERSITY OF ROCHESTER
	BEAM: Neutrino Area - 30 in. Hadron Beam		
	STUDY OF MULTIPARTICLE PRODUCTION IN A 30-INCH BUBBLE CHAMBER.		
	+-----+		
	Request	10 May, 71	240 K Pix total; combined experiment from proposals #62 and #80
	Approval	26 Aug, 71	50 K Pix in bare chamber with events where there is downstream spark chamber data to be shared with exp #2B
	Completed	26 Aug, 75	52 K Pix
141A	30-INCH P-P @ 200 #141A	Thomas H. Fields	ARGONNE NATIONAL LABORATORY FERMILAB IOWA STATE UNIVERSITY UNIVERSITY OF MARYLAND MICHIGAN STATE UNIVERSITY
	BEAM: Neutrino Area - 30 in. Hadron Beam		
	STUDY OF PP INTERACTIONS IN THE ANL 30-INCH HYDROGEN BUBBLE CHAMBER AT NAL.		
	+-----+		
	Request	25 Jun, 71	50 K Pix
	Approval	26 Aug, 71	50 K Pix in bare chamber with events where there is downstream spark chamber data to be shared with exp #2B
	Completed	27 Nov, 72	67 K Pix
142	SUPER-HEAVY ELEMENTS #142	Raymond W. Stoughton	ARGONNE NATIONAL LABORATORY OAK RIDGE NATIONAL LABORATORY
	BEAM: Neutrino Area - Miscellaneous		
	PROPOSAL FOR A SEARCH FOR SUPERHEAVY ELEMENTS BY IRRADIATIONS AT NAL.		
	+-----+		
	Request	12 Jul, 71	Parasitic Running with a total of 10 to the 18th protons on target
	Approval	26 Aug, 71	Target Exposure(s)
	Completed	4 Jun, 75	1 Target(s)
143A	30-INCH PI- - P @ 300 #143A	George R. Kalbfleisch	BROOKHAVEN NATIONAL LABORATORY CASE WESTERN RESERVE UNIVERSITY
	BEAM: Neutrino Area - 30 in. Hadron Beam		
	PROPOSAL FOR A RAPID SYSTEMATIC STUDY OF ALL INTERACTIONS IN A PI- - P EXPOSURE OF THE BARE 30-INCH CHAMBER AT 120 GEV/C.		
	+-----+		
	Request	12 Jul, 71	50 K Pix
	Approval	26 Aug, 71	50 K Pix in bare chamber with events where there is downstream spark chamber data to be shared with exp #2B
	Completed	10 Apr, 74	51 K Pix
147	SUPER-HEAVY ELEMENTS #147	Monique DeBeauvais	CRN, STRASBOURG (FRANCE) UNIVERSITY OF OTTAWA (CANADA)
	BEAM: Meson Area - Miscellaneous		
	PROPOSAL OF AN EXPERIMENT ON THE FISSION OF VERY HEAVY NUCLEI INDUCED BY 200 GEV PROTONS.		
	+-----+		
	Request	9 Jul, 71	Target Exposure(s)
	Approval	6 Aug, 73	Target Exposure(s)
	Completed	11 Jun, 75	4 Exposure(s)
152B	PHOTOPRODUCTION #152B	Clemens A. Heusch	UNIV. OF CALIFORNIA, SANTA CRUZ
	BEAM: Proton Area - East		
	PROPOSAL TO BUILD AN ELECTRON-PHOTON FACILITY AT NAL AND TO MEASURE PHOTON SCATTERING AT HIGH ENERGIES.		
	(Measurement of total cross sections, elastic and inelastic scattering meson production, and a search for new particles.)		
	+-----+		
	Request	19 Jul, 71	300 Hours with actual data taking of 160 hours
		23 Jun, 72	490 Hours total with an additional 190 hours of data taking
	Approval	4 Mar, 74	350 Hours with understanding that there will be a collaborative effort in development and construction of equipment with exp# 263
		28 Jun, 78	1,800 Hours approximately with the experiment to be considered complete by the time of the fall 1978 shutdown
	Completed	13 Nov, 78	1,950 Hours
154	30-INCH HYBRID #154	Irwin A. Pless	BROWN UNIVERSITY FERMILAB ILLINOIS INSTITUTE OF TECHNOLOGY UNIVERSITY OF ILLINOIS, CHAMPAIGN INDIANA UNIVERSITY JOHNS HOPKINS UNIVERSITY MASSACHUSETTS INST. OF TECHNOLOGY OAK RIDGE NATIONAL LABORATORY RUTGERS UNIVERSITY STEVENS INSTITUTE OF TECHNOLOGY UNIVERSITY OF TENNESSEE, KNOXVILLE YALE UNIVERSITY
	BEAM: Neutrino Area - 30 in. Hadron Beam		
	TEST OF PROPORTIONAL WIRE CHAMBERS IN HYBRID SYSTEMS.		
	+-----+		
	Request	23 Jun, 71	2,000 K Pix
	Approval	27 Aug, 71	20 K Pix with understanding that work will be done in two phases. Phase I - design, construction, installation, and initial operation of upstream tagging system
		6 Aug, 73	Phase II - use of downstream PWC's for feasibility test run of 20K pix with additional 100K pix to be taken with single type incident particles at a given energy
	Completed	13 Mar, 74	105 K Pix of pi- - p @ 150 GeV

155	15-FOOT EMI TEST #155 BEAM: Neutrino Area - Wide Band Horn PROPOSAL TO DEVELOP A PHASE I EXTERNAL MUON IDENTIFIER (EMI) FOR USE WITH THE NAL 30 CUBIC METER BUBBLE CHAMBER.	Vincent Z. Peterson	UNIVERSITY OF HAWAII AT MANOA LAWRENCE BERKELEY LABORATORY
	Request	15 Jul, 71	Test Running
	Approval	27 Aug, 71	Parasitic Running with understanding that completion of Phase I will include tests in neutrino beam with 15-ft bubble chamber in operation and number of pix to be determined at a later date
		17 Dec, 71	Parasitic Running with 100K pix to be taken from exp# 45A exposures taken when EMI was operating; film containing about 200 events to be delivered as soon as feasible to aid in preliminary tuneup and checking
		26 Jun, 74	50 K Pix with formal approval for dedicated pictures to follow successful analysis of 200 events from exp# 45A exposures
	Completed	30 Nov, 74	14 K Pix
156	EMULSION/PROTONS @ 200 #156 BEAM: Meson Area - Miscellaneous STUDY OF SECONDARY PARTICLES PRODUCED BY 200 AND 500 GEV PROTONS IN EMULSION CHAMBERS.	Kiyoshi Niu	AICHI UNIV. OF EDUCATION (JAPAN) KWANSEI GAKUIN UNIVERSITY (JAPAN) NAGOYA UNIVERSITY (JAPAN) UNIVERSITY OF TOKYO (JAPAN) YOKOHAMA NATIONAL UNIV. (JAPAN)
	Request	15 Aug, 71	Emulsion Exposure
	Approval	1 Sep, 71	Emulsion Exposure
	Completed	20 Sep, 72	13 Stack(s)
161	30-INCH P - P&NE @ 300 #161 BEAM: Neutrino Area - 30 in. Hadron Beam PROPOSAL TO SURVEY HIGH ENERGY PROTON COLLISIONS IN NEON AND TO SEARCH FOR ANOMALOUS PHOTON BUNDLES AT NAL.	James Mapp	UNIVERSITY OF WISCONSIN - MADISON
	Request	13 Oct, 71	50 K Pix
	Approval	6 Aug, 73	50 K Pix
	Completed	25 Jun, 74	51 K Pix
163A	30-INCH PI- - P&NE @ 200 #163A BEAM: Neutrino Area - 30 in. Hadron Beam PROPOSAL FOR A STUDY OF THE INTERACTION OF HIGH ENERGY PI- WITH NEON.	William D. Walker	DUKE UNIVERSITY UNIVERSITY OF NORTH CAROLINA
	Request	4 Dec, 71	50 K Pix
	Approval	19 Jul, 72	50 K Pix
	Completed	18 Jun, 74	52 K Pix
171	EMULSION/PROTONS @ 200 #171 BEAM: Meson Area - Miscellaneous PROPOSED EMULSION EXPERIMENT SEARCH FOR SHORT LIVED PARTICLES AT HIGH ENERGIES.	Jere J. Lord	UNIVERSITY OF WASHINGTON
	Request	10 May, 72	Emulsion Exposure
	Approval	1 Aug, 72	Emulsion Exposure
	Completed	20 Sep, 72	6 Stack(s)
172	15-FOOT ANTI-NEUTRINO/H2&NE#172 BEAM: Neutrino Area - Wide Band Horn ANTINEUTRINO INTERACTIONS IN THE 15-FOOT H2-NEON BUBBLE CHAMBER.	Henry J. Lubatti	UNIV. OF CALIFORNIA, BERKELEY UNIVERSITY OF HAWAII AT MANOA LAWRENCE BERKELEY LABORATORY UNIVERSITY OF WASHINGTON
	Request	16 May, 72	50 K Pix
	Approval	19 Jul, 72	50 K Pix
	Completed	25 May, 76	49 K Pix
177A	PROTON-PROTON ELASTIC #177A BEAM: Proton Area - West EARLY MEASUREMENT OF HIGH ENERGY P P LARGE ANGLE ELASTIC SCATTERING.	Jay Orear	CORNELL UNIVERSITY LEBEDEV PHYSICAL INST. (RUSSIA) MCGILL UNIVERSITY (CANADA) NORTHEASTERN UNIVERSITY
	Request	12 Jun, 72	100 Hours for initial run
		27 Oct, 72	700 Hours total with additional 600 hours for data
	Approval	13 Aug, 73	100 Hours for Phase I; counter tests to demonstrate success of proposed technique
		28 Jun, 76	700 Hours with 600 hours additional for data
		19 Nov, 76	1,500 Hours with additional 800 hours to collect data at 200 GeV and 400 GeV to t-values of 18 GeV squared; completion of run expected by 15 Feb 1977
		7 Mar, 77	2,200 Hours with additional 700 hours to collect data in high t region with completion of experiment expected at end of April 1977
	Completed	19 Apr, 77	2,400 Hours
178	MULTIPLICITIES #178 BEAM: Meson Area - M6 Beam A STUDY OF THE AVERAGE MULTIPLICITY AND MULTIPLICITY DISTRIBUTIONS IN HADRON-NUCLEUS COLLISIONS AT HIGH ENERGIES. (Using Cerenkov counter pulse height analysis.)	Wit Busza	CARELTON UNIVERSITY (CANADA) FERMILAB MASSACHUSETTS INST. OF TECHNOLOGY
	Request	16 Jun, 72	60 Hours including 20 hours for tests
	Approval	6 Aug, 73	100 Hours with understanding that running will be on a parasitic basis during tuning of M6 beam line by exp# 96
		25 Oct, 74	200 Hours with an additional 100 hours of running in the M6 beam line
	Completed	14 Aug, 75	800 Hours
180	15-FOOT ANTI-NEUTRINO/H2&NE#180 BEAM: Neutrino Area - Wide Band Horn A STUDY OF ANTINEUTRINO INTERACTIONS IN THE NAL 15-FOOT BUBBLE CHAMBER, FILLED WITH HYDROGEN AND NEON.	Pavel F. Ermolov	FERMILAB UNIVERSITY OF MICHIGAN - ANN ARBOR ITEP, MOSCOW (RUSSIA) IHEP, PROTIVNO (SERPUKHOV) (RUSSIA)
	Request	23 Jun, 72	200 K Pix
	Approval	11 Jul, 72	50 K Pix of antineutrinos to run before exp# 172 and to have first choice of the two H2/neon mixtures
		29 Jun, 76	200 K Pix including an additional 150K pix; with the expectation that the experiment will involve a total of 500K pix
	Approved/Inactive	1 Jun, 77	273 K Pix as of 01 Jun 1977

181	EMULSION/PROTONS @ 300 #181 BEAM: Neutrino Area - Miscellaneous THE DIRECT PRODUCTION OF ELECTRON PAIRS IN NUCLEAR EMULSION BY 100 AND 200 GEV PROTONS.	Arthur S. Cary	HARVEY MUDD COLLEGE
	Request	27 Jul, 72	Emulsion Exposure
	Approval	15 Nov, 72	Emulsion Exposure
	Completed	20 Oct, 73	3 Stack(s)
183	EMULSION/PROTONS @ 200 #183 BEAM: Meson Area - Miscellaneous A PROPOSAL OF THE PHOTOEMULSION EXPERIMENT AT THE NATIONAL ACCELERATOR LABORATORY (BATAVIA).	M. I. Tretjakova	LEBEDEV PHYSICAL INST. (RUSSIA)
	Request	7 Jul, 72	Emulsion Exposure
	Approval	1 Aug, 72	Emulsion Exposure
	Completed	20 Sep, 72	3 Stack(s)
184	PARTICLE SEARCH #184 BEAM: Internal Target Area (C-0) SEARCH FOR A NEW CLASS OF PENETRATING MASSIVE PARTICLES AT C-0.	Peter J. Wanderer	UNIVERSITY OF CHICAGO HARVARD UNIVERSITY UNIVERSITY OF PENNSYLVANIA UNIVERSITY OF WISCONSIN - MADISON
	Request	14 Sep, 72	Unspecified
	Approval	5 Oct, 72	400 Hours with installation to begin at time of removal of exp# 120 and extending for a period of one month
		6 Aug, 73	600 Hours with approval for occupancy at C-0 for 6 weeks
		22 Feb, 74	760 Hours with an authorized extension of 160 hours
	Completed	29 May, 74	800 Hours
186	PROTON-DEUTERON SCATTERING #186 BEAM: Internal Target Area (C-0) A PROPOSAL TO STUDY SMALL ANGLE PROTON-DEUTERON SCATTERING. (Using a gas jet target with deuterium and the internal proton beam; t from 0.001 - 0.020.)	Adrian Melissinos	FERMILAB JINR, DUBNA (RUSSIA) UNIVERSITY OF ROCHESTER ROCKEFELLER UNIVERSITY
	Request	19 Oct, 72	400 Hours
	Approval	1 Nov, 72	400 Hours
	Completed	19 Aug, 74	450 Hours
187	PARTICLE SEARCH #187 BEAM: Proton Area - Center PHASE 0.8 - SEARCH FOR LONG-LIVED MASSIVE OBJECTS (HIGH ENERGY CALIBRATION RUN). (Relying on r.f. bunching and time of flight measurement.)	Leon M. Lederman	COLUMBIA UNIVERSITY FERMILAB
	Request	5 Sep, 72	Unspecified
	Approval	30 Oct, 72	100 Hours
	Completed	6 Nov, 73	200 Hours
188	PROTON-NUCLEON INCLUSIVE #188 BEAM: Internal Target Area (C-0) A PROPOSAL TO MEASURE CROSS SECTIONS FOR P-P TO P-X, N-X AS A FUNCTION OF S AND MX SQUARED USING THE INTERNAL TARGET FACILITY AT NAL.	Felix Sannes	UNIV. OF ILLINOIS, CHICAGO CIRCLE IMPERIAL COLLEGE (ENGLAND) RUTGERS UNIVERSITY UPSALA COLLEGE
	Request	25 Oct, 72	200 Hours
	Approval	1 Nov, 72	200 Hours
	Completed	9 May, 73	1,050 Hours
189	EMULSION/PROTONS @ 200 #189 BEAM: Meson Area - Miscellaneous NUCLEAR EMULSION EXPOSURES TO 400 GEV. (For student laboratory use.)	David Ritson	STANFORD UNIVERSITY
	Request	16 Oct, 72	Emulsion Exposure
	Approval	2 Nov, 72	Emulsion Exposure
	Completed	20 Sep, 72	2 Plate(s)
194	30-INCH P - D @ 100 #194 BEAM: Neutrino Area - 30 in. Hadron Beam PROPOSAL TO STUDY PROTON-DEUTERON INTERACTIONS IN THE 30-INCH BUBBLE CHAMBER.	C. Thornton Murphy	CARNEGIE-MELLON UNIVERSITY FERMILAB UNIVERSITY OF MICHIGAN - ANN ARBOR SUNY AT STONY BROOK
	Request	13 Nov, 72	200 K Pix
	Approval	1 Mar, 74	100 K Pix in bare chamber with downstream chamber data if it can be arranged
	Completed	20 Aug, 76	92 K Pix
195	EMULSION/PROTONS @ 300 #195 BEAM: Neutrino Area - Miscellaneous PROPOSAL TO MEASURE THE LIFETIME OF THE NEUTRAL PION.	Yu K. Lim	CRFC, CAMBRIDGE EMMANUEL COLLEGE MISSISSIPPI STATE UNIVERSITY UNIVERSITY OF SINGAPORE(SINGAPORE)
	Request	13 Nov, 72	Emulsion Exposure
	Approval	15 Nov, 72	Emulsion Exposure
	Completed	10 Jun, 75	3 Stack(s)
196	30-INCH P - D @ 400 #196 BEAM: Neutrino Area - 30 in. Hadron Beam PROTON-DEUTERON INTERACTIONS IN THE BARE 30-INCH BUBBLE CHAMBER.	Roderich J. Engelmann	CARNEGIE-MELLON UNIVERSITY FERMILAB UNIVERSITY OF MICHIGAN - ANN ARBOR SUNY AT STONY BROOK
	Request	13 Nov, 72	100 K Pix
	Approval	21 Mar, 74	100 K Pix in bare chamber with downstream chamber data if it can be arranged
	Completed	20 Oct, 75	109 K Pix
198A	PROTON-NUCLEON SCATTERING #198A BEAM: Internal Target Area (C-0) A PROPOSAL FOR A MAGNETIC RECOIL SPECTROMETER FOR THE GAS JET TARGET. (Use of the gas jet target with H2 and D2 to study p - p and p - d scattering with the internal proton beam; t from 0.15 - 3.0.)	Stephen L. Olsen	IMPERIAL COLLEGE (ENGLAND) UNIVERSITY OF ROCHESTER RUTGERS UNIVERSITY
	Request	22 Dec, 72	800 Hours
	Approval	22 Mar, 74	800 Hours contingent on construction of C-0 extension
		26 Jun, 74	800 Hours with the understanding that concurrent running with exp# 313 be arranged whenever possible
	Completed	19 Apr, 77	900 Hours

199	MASSIVE PARTICLE SEARCH #199 BEAM: Neutrino Area - Miscellaneous SEARCH FOR WEAKLY PRODUCED MASSIVE LONG LIVED PARTICLES AT NATL. (Using a threshold Cerenkov counter.)	Sherman Frankel	FERMILAB UNIVERSITY OF PENNSYLVANIA
	Request 21 Dec, 72 Target Exposure(s) Approval 15 Jan, 73 Target Exposure(s) Completed 22 Aug, 73 2 Targets Exposed		
202	TACHYON MONOPOLE #202 BEAM: Neutrino Area - Miscellaneous SEARCH FOR TACHYON MONOPOLES IN COSMIC RAYS ABOVE 15-FOOT BUBBLE CHAMBER. (Using magnet fringe field.)	David F. Bartlett	UNIVERSITY OF COLORADO AT BOULDER PRINCETON UNIVERSITY
	Request 1 Feb, 73 800 Hours of which half would be at zero field Approval 22 Aug, 73 Parasitic Running Completed 19 May, 76 Cosmic Ray Running		
203A	MUON #203A BEAM: Neutrino Area - Muon/Hadron Beam FEASIBLE SEARCH FOR HEAVY NEUTRAL MUONS PREDICTED BY GAUGE THEORIES AND CONCURRENT MEASUREMENT OF DEEP-INELASTIC VIRTUAL COMPTON SCATTERING.	Leroy T. Kerth	UNIV. OF CALIFORNIA, BERKELEY FERMILAB LAWRENCE BERKELEY LABORATORY PRINCETON UNIVERSITY
	Request 9 Mar, 73 600 Hours with muon beam intensity of 5×10 to the 6th per pulse Approval 26 Mar, 75 500 Hours with formal approval of 1×10 to the 18th protons 23 Mar, 78 1,200 Hours with the expectation to run the experiment until about April 27, 1978 Completed 18 May, 78 1,200 Hours		
205A	EMULSION/MUONS @ 150 #205A BEAM: Neutrino Area - Miscellaneous PHENOMENOLOGICAL STUDY OF MUON-NUCLEON COLLISION AT ENERGY MORE THAN 100 GEV IN EMULSION.	Osamu Kusumoto	KINKI UNIVERSITY (JAPAN) KOBE UNIVERSITY (JAPAN) OKAYAMA UNIVERSITY (JAPAN) OSAKA CITY UNIVERSITY (JAPAN) OSAKA SCIENCE EDUC. INST. (JAPAN) UNIVERSITY OF TOKYO (JAPAN)
	Request 4 Apr, 73 Emulsion Exposure Approval 15 Jun, 73 Emulsion Exposure Completed 16 Oct, 73 2 Stack(s)		
209	30-INCH P - D @ 300 #209 BEAM: Neutrino Area - 30 in. Hadron Beam A STUDY OF 300 GEV/C P D INTERACTIONS IN THE THIRTY-INCH BUBBLE CHAMBER.	Fu Tak Dao	CALIFORNIA INSTITUTE OF TECHNOLOGY IOWA STATE UNIVERSITY TUFTS UNIVERSITY VANDERBILT UNIVERSITY
	Request 1 May, 73 50 K Pix Approval 21 Mar, 74 100 K Pix in bare chamber with downstream chamber data if it can be arranged Completed 7 Oct, 76 106 K Pix		
211	BEAM DUMP #211 BEAM: Neutrino Area - Miscellaneous PROPOSAL FOR RADIATION MEASUREMENTS AROUND A PROTON BEAM DUMP AT 300 GEV. (Early measurements to confirm calculations for CERN; very reduced version of exp #108.)	Klaus Goebel	CERN (SWITZERLAND) FERMILAB
	Request 18 Apr, 73 10 Hours with a total of 10 to the 15th protons Approval 20 Apr, 73 10 Hours Completed 14 Nov, 73 2 Hours		
216	FORM FACTOR #216 BEAM: Meson Area - M1 Beam A MEASUREMENT OF THE PION FORM FACTOR BY DIRECT PION-ELECTRON SCATTERING.	Donald H. Stork	UNIV. OF CALIFORNIA, LOS ANGELES FERMILAB JINR, DUBNA (RUSSIA) NOTRE DAME UNIVERSITY UNIVERSITY OF PITTSBURGH
	Request 25 May, 73 630 Hours Approval 6 Aug, 73 100 Hours for testing and running at 100 GeV to assess background effects 7 Jul, 75 600 Hours with additional 500 hours of running in M-1 beam line and encouragement to select a single high energy for measurement Completed 1 Oct, 75 900 Hours		
217	30-INCH PI+ & P - P @ 200 #217 BEAM: Neutrino Area - 30 in. Hadron Beam A COMPARISON OF 100 GEV AND 200 GEV PI+ - P INTERACTIONS.	Richard L. Lander	UNIV. OF CALIFORNIA, DAVIS LAWRENCE BERKELEY LABORATORY SLAC
	Request 29 May, 73 50 K Pix Approval 6 Aug, 73 50 K Pix Completed 15 May, 74 85 K Pix		
218	30-INCH PI - D @ 200 #218 BEAM: Neutrino Area - 30 in. Hadron Beam PION-DEUTERON INTERACTIONS AT 200 GEV/C.	Philip Marvin Yager	UNIV. OF CALIFORNIA, DAVIS INP, KRAKOW (POLAND) WARSAW UNIVERSITY, INP, (POLAND) UNIVERSITY OF WASHINGTON
	Request 29 May, 73 50 K Pix Approval 21 Mar, 74 50 K Pix in bare chamber with downstream chamber data if it can be arranged Completed 18 Sep, 74 72 K Pix		
221	PROTON-PROTON INELASTIC #221 BEAM: Internal Target Area (C-0) P - P INELASTIC SCATTERING IN THE DIFFRACTIVE REGION. (Continuation of experiment #14A.)	Paolo Franzini	COLUMBIA UNIVERSITY SUNY AT STONY BROOK
	Request 8 Jun, 73 400 Hours including 200 hours of setup and tuning Approval 6 Aug, 73 400 Hours Completed 5 Sep, 74 950 Hours		

226	K ZERO CHARGE RADIUS #226 BEAM: Meson Area - M4 Beam COHERENT K-SHORT REGENERATION BY ELECTRONS.	Valentine L. Telegdi	UNIVERSITY OF CHICAGO LHE, ETH HONGGERBERG (SWITZERLAND) UNIVERSITY OF WISCONSIN - MADISON
	Request	12 Jun, 73 720 Hours 15 Nov, 74 2,100 Hours	
	Approval	22 Nov, 74 500 Hours 30 Jun, 76 600 Hours	
	Completed	17 Mar, 77 1,200 Hours	
228	30-INCH PI+ & P - P @ 60 #228 BEAM: Neutrino Area - 30 in. Hadron Beam PROPOSAL TO EXTEND THE ENERGY RANGE OF A STUDY OF MULTIPARTICLE PRODUCTION IN P - P COLLISIONS. (Request for the remaining pictures for exp #252 to be with a momentum of 60 GeV/c.)	Thomas Ferbel	UNIVERSITY OF MICHIGAN - ANN ARBOR UNIVERSITY OF ROCHESTER
	Request	16 Jun, 73 25 K Pix 20 Feb, 74 35 K Pix	
	Approval	6 Aug, 73 25 K Pix 14 Mar, 74 35 K Pix	
	Completed	15 Apr, 74 37 K Pix	
229	DETECTOR DEVELOPMENT #229 BEAM: Meson Area - M1 Beam A PROPOSAL FOR TESTING A TRANSITION RADIATION DETECTOR AT NAL.	Luke C. L. Yuan	BROOKHAVEN NATIONAL LABORATORY
	Request	19 Jun, 73 100 Hours	
	Approval	23 Aug, 73 Parasitic Running for about 200 hours	
	Completed	16 Nov, 74 300 Hours	
230	MULTIGAMMA #230 BEAM: Meson Area - M3 Beam A SEARCH FOR "SCHEIN EVENTS" AND EVENTS WITH A HIGH MULTIPLICITY OF GAMMAS.	Michael J. Longo	UNIVERSITY OF MICHIGAN - ANN ARBOR
	Request	25 Jun, 73 40 Hours	
	Approval	6 Aug, 73 40 Hours	
	Completed	24 Apr, 74 50 Hours	
232	EMULSION/PROTONS @ 300 #232 BEAM: Neutrino Area - Miscellaneous 400-GEV PROTONS ON COMPLEX NUCLEI.	David T. King	UNIVERSITY OF TENNESSEE, KNOXVILLE
	Request	6 Jul, 73 Emulsion Exposure	
	Approval	16 Aug, 73 Emulsion Exposure	
	Completed	20 Oct, 73 2 Stack(s)	
233	EMULSION/PROTONS @ 300 #233 BEAM: Neutrino Area - Miscellaneous 300 GEV (AND 400 GEV) PROTON INTERACTIONS IN NUCLEAR EMULSION.	Jacques D. Hebert	UNIVERSITY OF BARCELONA (SPAIN) UNIVERSITY OF BELGRADE (YUGOSLAVIA) IAP, BUCHAREST (ROMANIA) CRN, STRASBOURG (FRANCE) FERMILAB UNIVERSITY OF LUND (SWEDEN) MCGILL UNIVERSITY (CANADA) UNIVERSITY OF NANCY (FRANCE) UNIVERSITY OF OTTAWA (CANADA) UNIV. OF PARIS VI, LPG (FRANCE) UNIVERSITY OF QUEBEC (CANADA) LRC, LYON (FRANCE) INFN, ROME (ITALY) IFC, VALENCIA (SPAIN)
	Request	16 Jul, 73 Emulsion Exposure	
	Approval	16 Aug, 73 Emulsion Exposure	
	Completed	20 Oct, 73 8 Stack(s)	
234	15-FOOT ENGINEERING RUN #234 BEAM: Neutrino Area - 15 ft. Hadron Beam AN ENGINEERING RUN FOR THE NAL 15-FOOT CRYOGENIC BUBBLE CHAMBER.	Fred Russell Huson	FERMILAB FLORIDA STATE UNIVERSITY
	Request	1 Aug, 73 50 K Pix	
	Approval	6 Aug, 73 50 K Pix	
	Completed	5 Nov, 74 57 K Pix of pi- - p interactions at 250 GeV/c	
236A	HADRON JETS #236A BEAM: Meson Area - M1 Beam A PROPOSAL TO EXPLORE THE LARGE-PT DOMAIN: INCLUSIVE CROSS SECTIONS AND POSSIBLE JET STRUCTURE.	Paul M. Mockett	FERMILAB TUFTS UNIVERSITY UNIVERSITY OF WASHINGTON
	Request	13 Aug, 73 550 Hours for tests and data 16 Dec, 76 1,150 Hours including an additional 400 hours for data and 200 hours for tests	
	Approval	22 Jan, 74 550 Hours 1 Apr, 77 1,150 Hours including additional 600 hours to complete experiment during a six week running period	
	Completed	20 Jul, 77 1,700 Hours	
237	EMULSION/PROTONS @ 300 #237 BEAM: Neutrino Area - Miscellaneous EMULSION EXPOSURE TO 300 GEV PROTONS.	Jere J. Lord	UNIVERSITY OF WASHINGTON
	Request	14 Aug, 73 Emulsion Exposure	
	Approval	11 Sep, 73 Emulsion Exposure	
	Completed	10 Jun, 75 5 Stack(s)	
238	EMULSION/PROTONS @ 400 #238 BEAM: Neutrino Area - Miscellaneous EMULSION EXPOSURE TO 400 GEV PROTONS.	Jere J. Lord	UNIVERSITY OF WASHINGTON
	Request	14 Aug, 73 Emulsion Exposure	
	Approval	12 Mar, 74 Emulsion Exposure	
	Completed	9 Dec, 75 9 Stack(s)	

239	LONG-LIVED PARTICLES #239 BEAM: Neutrino Area - Miscellaneous PROPOSAL FOR A FURTHER SEARCH FOR LONG LIVED PARTICLES AT NAL. (With a Cerenkov counter looking at the neutrino target from the 90 degree monitor pipe.)	William Frati	FERMILAB UNIVERSITY OF PENNSYLVANIA
	+-----+		
	Request	15 Jul, 73	Parasitic Running
	Approval	6 Dec, 73	Parasitic Running
	Completed	3 Feb, 74	350 Hours
242	EMULSION/PROTONS @ 300 #242 BEAM: Neutrino Area - Miscellaneous STUDY OF SECONDARY PARTICLES PRODUCED BY 300 GEV PROTONS IN EMULSION CHAMBERS.	Kiyoshi Niu	AICHI UNIV. OF EDUCATION (JAPAN) NAGOYA UNIVERSITY (JAPAN) YOKOHAMA NATIONAL UNIV. (JAPAN)
	+-----+		
	Request	28 Sep, 73	Emulsion Exposure
	Approval	22 Nov, 73	Emulsion Exposure
	Completed	20 Oct, 73	2 Stack(s)
243	EMULSION/PROTONS @ 400 #243 BEAM: Neutrino Area - Miscellaneous STUDY OF SECONDARY PARTICLES PRODUCED BY 400 GEV PROTONS IN EMULSION CHAMBERS.	Kiyoshi Niu	AICHI UNIV. OF EDUCATION (JAPAN) KONAN UNIVERSITY (JAPAN) NAGOYA UNIVERSITY (JAPAN) YOKOHAMA NATIONAL UNIV. (JAPAN)
	+-----+		
	Request	28 Sep, 73	Emulsion Exposure
	Approval	12 Mar, 74	Emulsion Exposure
	Completed	9 Dec, 75	7 Stack(s)
244	EMULSION/PROTONS @ 300 #244 BEAM: Neutrino Area - Miscellaneous INTERACTION OF 300 GEV PROTONS IN NUCLEAR EMULSION.	Piyare L. Jain	SUNY AT BUFFALO
	+-----+		
	Request	1 Oct, 73	Emulsion Exposure
	Approval	22 Nov, 73	Emulsion Exposure
	Completed	20 Oct, 73	1 Stack(s)
245	EMULSION/PROTONS @ 400 #245 BEAM: Neutrino Area - Miscellaneous INTERACTION OF 400 GEV PROTONS IN NUCLEAR EMULSION.	Piyare L. Jain	SUNY AT BUFFALO
	+-----+		
	Request	1 Oct, 73	Emulsion Exposure
	Approval	3 Mar, 74	Emulsion Exposure
	Completed	9 Dec, 75	1 Stack(s)
247	PARTICLE SEARCH #247 BEAM: Neutrino Area - Wide Band Horn A PROPOSED EXPERIMENT TO SEARCH FOR HEAVY LEPTONS. (Using a hybrid emulsion-spark chamber arrangement.)	Eric H. S. Burhop	UNIV. COLLEGE DUBLIN (IRELAND) FERMILAB UNIVERSITY OF LIBRE (BELGIUM) LONDON UNIVERSITY COLLEGE (ENGLAND) INFN, ROME (ITALY) UNIVERSITY OF STRASBOURG (FRANCE)
	+-----+		
	Request	21 Sep, 73	1,000 Hours with request for a bombardment of 2 x 10 to the 18th protons
	Approval	2 Oct, 73	Unspecified but with expectation of test running for feasibility studies
		26 Mar, 75	1,000 Hours with formal approval for 2 x 10 to the 18th protons subject to the condition that running is compatible with exp# 310 and the 15-ft bubble chamber program
		11 Mar, 76	1,000 Hours with formal approval for 2 x 10 to the 18th protons and high priority
	Completed	18 May, 76	350 Hours
248	NEUTRON ELASTIC SCATTERING #248 BEAM: Meson Area - M3 Beam NEUTRON-PROTON DIFFRACTION SCATTERING UP TO 300 GEV. (Differential cross sections with t from 0.1 to 3.5; formerly referred to as exp #411.)	Michael J. Longo	UNIVERSITY OF MICHIGAN - ANN ARBOR
	+-----+		
	Request	15 May, 70	700 Hours as an estimate
	Approval	1 Aug, 70	400 Hours
	Completed	10 Dec, 76	2,400 Hours
249	EMULSION/PROTONS @ 400 #249 BEAM: Neutrino Area - Miscellaneous CRACOW EMULSION EXPOSURE TO 400 GEV PROTONS.	Wladyslaw Wolter	INP, KRAKOW (POLAND)
	+-----+		
	Request	8 Oct, 73	Emulsion Exposure
	Approval	12 Mar, 74	Emulsion Exposure
	Completed	9 Dec, 75	3 Stack(s)
250	EMULSION/PROTONS @ 300 #250 BEAM: Neutrino Area - Miscellaneous PHENOMENOLOGICAL STUDY OF PROTON-NUCLEUS COLLISION AT NAL ENERGIES IN EMULSION (300 GEV).	Osamu Kusumoto	KINKI UNIVERSITY (JAPAN) KOBE UNIVERSITY (JAPAN) OSAKA CITY UNIVERSITY (JAPAN) OSAKA SCIENCE EDUC. INST. (JAPAN) WAKAYAMA MEDICAL COLLEGE (JAPAN)
	+-----+		
	Request	10 Oct, 73	Emulsion Exposure
	Approval	22 Nov, 73	Emulsion Exposure
	Completed	20 Oct, 73	1 Stack(s)
251	EMULSION/PROTONS @ 400 #251 BEAM: Neutrino Area - Miscellaneous PHENOMENOLOGICAL STUDY OF PROTON-NUCLEUS COLLISION AT NAL ENERGIES IN EMULSION (400 GEV).	Osamu Kusumoto	KINKI UNIVERSITY (JAPAN) KOBE UNIVERSITY (JAPAN) OSAKA CITY UNIVERSITY (JAPAN) OSAKA SCIENCE EDUC. INST. (JAPAN) WAKAYAMA MEDICAL COLLEGE (JAPAN)
	+-----+		
	Request	10 Oct, 73	Emulsion Exposure
	Approval	22 Oct, 73	Emulsion Exposure
	Completed	9 Dec, 75	3 Stack(s)
252	30-INCH P-P @ 100 #252 BEAM: Neutrino Area - 30 in. Hadron Beam STUDY OF MULTIPARTICLE PRODUCTION IN A 30-INCH BUBBLE CHAMBER. (Formerly known as experiment #1381.)	Thomas Ferbel	UNIVERSITY OF MICHIGAN - ANN ARBOR UNIVERSITY OF ROCHESTER
	+-----+		
	Request	10 May, 71	240 K Pix
	Approval	26 Aug, 71	50 K Pix in bare chamber with events where there is downstream spark chamber data to be shared with exp #2B
	Completed	6 Dec, 72	33 K Pix

253	NEUTRINO #253 BEAM: Neutrino Area - Wide Band Horn NEUTRINO-ELECTRON SCATTERING AT NAL.	Luke W. Mo	IHEP, BEIJING (PRC) UNIVERSITY OF MARYLAND NATIONAL SCIENCE FOUNDATION UNIVERSITY OF OXFORD (ENGLAND) VIRGINIA TECH
	Request	15 Oct, 73	Parasitic Running expected to total 1,000 hours
	Approval	7 Jul, 75	Parasitic Running
	Completed	7 Mar, 79	2,050 Hours
254	NEUTRINO #254 BEAM: Neutrino Area - Dichromatic PROPOSAL TO SEARCH FOR A SECOND MUON NEUTRINO. (Dichromatic beam incident on target calorimeter with muon spectrometer of exp #21A; muon monitoring instrumentation will be added.)	George R. Kalbfleisch	BROOKHAVEN NATIONAL LABORATORY CALIFORNIA INSTITUTE OF TECHNOLOGY FERMILAB PURDUE UNIVERSITY
	Request	17 Oct, 73	300 Hours with total flux of 3×10 to the 17th protons
	Approval	22 Nov, 74	300 Hours with a formal approval for 3×10 to the 17th protons and the hope that running can be coordinated with exp# 21
	Completed	15 Oct, 75	550 Hours
255	EMULSION/MUONS @ 150 #255 BEAM: Neutrino Area - Miscellaneous EXPOSURE OF NUCLEAR EMULSIONS TO A BEAM OF 150 GEV MUONS AT THE NATIONAL ACCELERATOR LABORATORY.	Piyare L. Jain	SUNY AT BUFFALO
	Request	15 Oct, 73	Emulsion Exposure
	Approval	22 Oct, 73	Emulsion Exposure
	Completed	16 Oct, 73	1 Stack(s)
258	PION INCLUSIVE #258 BEAM: Proton Area - West A PROPOSAL TO MEASURE PARTICLES PRODUCED AT HIGH TRANSVERSE MOMENTUM BY PIONS.	Melvyn Jay Shochet	UNIVERSITY OF CHICAGO PRINCETON UNIVERSITY
	Request	22 Oct, 73	Unspecified
	Approval	26 Jun, 74	800 Hours contingent upon development of a suitable beam
	Completed	9 Jul, 79	1,500 Hours
260	HADRON JETS #260 BEAM: Meson Area - M6 Beam A PROPOSAL TO STUDY HIGH PT PHYSICS WITH A MULTIPARTICLE SPECTROMETER.	Donald W. McLeod	CALIFORNIA INSTITUTE OF TECHNOLOGY UNIV. OF CALIFORNIA, LOS ANGELES FERMILAB UNIV. OF ILLINOIS, CHICAGO CIRCLE INDIANA UNIVERSITY MAX-PLANCK INSTITUTE (GERMANY)
	Request	26 Oct, 73	650 Hours
	Approval	16 Nov, 73	200 Hours to come out of the 800 hours previously approved for exp# 110A
	Completed	20 Sep, 76	2,300 Hours
		9 Aug, 76	1,150 Hours including an extension of 500 hours to complete the experiment
		13 Aug, 76	950 Hours for data including an additional 750 hours with the understanding that the commitment to the experiment is to be complete before a shutdown in September 1976
261	DETECTOR DEVELOPMENT #261 BEAM: Meson Area - M1 Beam PROPOSAL TO TEST TRANSITION COUNTERS AT NAL.	Ching Lin Wang	BROOKHAVEN NATIONAL LABORATORY FERMILAB
	Request	26 Oct, 73	Parasitic Running expected to total 200 hours
	Approval	17 Jan, 74	Parasitic Running for about 200 hours
	Completed	20 Nov, 74	600 Hours
262	NEUTRINO #262 BEAM: Neutrino Area - Dichromatic NEUTRAL CURRENT INVESTIGATION AT NAL. (Using the Dichromatic beam, target calorimeter, and spectrometer of exp. #21A.)	Barry C. Barish	CALIFORNIA INSTITUTE OF TECHNOLOGY FERMILAB
	Request	28 Oct, 73	300 Hours to include 3×10 to the 17th protons
	Approval	16 Nov, 73	300 Hours with understanding that this will include 3×10 to the 17th protons
	Completed	20 Mar, 74	400 Hours
264	EMULSION/PI- @ 200 #264 BEAM: Neutrino Area - Miscellaneous EXPOSURE OF EMULSIONS TO 200-300 GEV PI- FOR NEW DETERMINATION OF MEAN LIFE OF PI ZERO.	Poh Shien Young	MISSISSIPPI STATE UNIVERSITY UNIVERSITY OF TENNESSEE, KNOXVILLE
	Request	31 Oct, 73	Emulsion Exposure
	Approval	12 Mar, 74	Emulsion Exposure
	Completed	7 Oct, 74	2 Stack(s)
265	EMULSION/PROTONS @ 400 #265 BEAM: Neutrino Area - Miscellaneous EXPOSURE OF EMULSIONS TO 400 GEV PROTONS FOR NEW DETERMINATION OF MEAN LIFE OF PI ZERO.	Poh Shien Young	CRFC, CAMBRIDGE MISSISSIPPI STATE UNIVERSITY
	Request	31 Oct, 73	Emulsion Exposure
	Approval	12 Mar, 74	Emulsion Exposure
	Completed	9 Dec, 75	3 Stack(s)

268	INCLUSIVE PHOTON #268 BEAM: Meson Area - M2 Beam A PROPOSAL TO STUDY MESON PRODUCTION AT LARGE P- TRANSVERSE WITH A GAMMA RAY DETECTOR. (Induced by protons @ 300 GeV and by pi+- @ 100 and 200 GeV; using photon detector of exp #111.)	Joel Mellema	BROOKHAVEN NATIONAL LABORATORY CALIFORNIA INSTITUTE OF TECHNOLOGY LAWRENCE BERKELEY LABORATORY
	Request	5 Nov, 73	900 Hours total with an initial run of 500 hours
		3 Nov, 75	1,200 Hours including a three-week extension
	Approval	21 Mar, 74	100 Hours of running in diffracted proton beam to demonstrate feasibility
		26 Jun, 74	100 Hours with formal approval for parasitic running using a pion beam in front of exp# 51
		22 Nov, 74	600 Hours including an additional 500 hours of running in a pion beam
		10 Nov, 75	900 Hours including an additional three week run to obtain data at a forward angle with a 200 GeV beam
	Completed	11 Feb, 76	1,850 Hours
271	EMULSION/PROTONS @ 200 #271 BEAM: Neutrino Area - Miscellaneous MULTIPARTICLE PRODUCTION IN NUCLEI BY PROTONS OF SEVERAL HUNDRED GEV. (Using target materials consisting of fine wires imbedded in emulsion or foils covering the emulsion; 200 GeV exposure.)	Kurt Gottfried	IAP, BUCHAREST (ROMANIA) CERN (SWITZERLAND) CORNELL UNIVERSITY UNIVERSITY OF LUND (SWEDEN)
	Request	30 Nov, 73	Emulsion Exposure
	Approval	16 Jan, 74	Emulsion Exposure
	Completed	10 Jun, 75	10 Stack(s)
272	HADRON DISSOCIATION #272 BEAM: Meson Area - M1 Beam PROPOSAL TO MEASURE COHERENT DISSOCIATION OF PI-, K-, AND PBAR INTO TWO-BODY SYSTEMS AT FERMILAB ENERGIES.	Thomas Ferbel	BROOKHAVEN NATIONAL LABORATORY FERMILAB UNIVERSITY OF MINNESOTA UNIVERSITY OF ROCHESTER
	Request	3 Dec, 73	600 Hours
		9 Jun, 75	900 Hours total with the additional 300 hours of data taking at 150 and 300 GeV/c incident momentum
	Approval	7 Jul, 75	600 Hours
	Completed	3 Dec, 79	1,950 Hours
275	PLASTIC DETECTORS #275 BEAM: Neutrino Area - Miscellaneous EXPOSURE OF PLASTIC-DETECTOR STACKS TO A 300 GEV PROTON BEAM AT NAL.	Wolfgang Enge	CHRISTIAN-ALBRECHTS UNIV. (GERMANY)
	Request	17 Dec, 73	Detector Exposure
	Approval	20 Oct, 73	Detector Exposure
	Completed	20 Oct, 73	4 Stack(s)
276	QUARK #276 BEAM: Neutrino Area - Miscellaneous A SEARCH FOR STABLE INTEGRALLY CHARGED MASSIVE PARTICLES (HAN-NAMBU QUARKS). (Mass spectroscopic analysis of irradiated target.)	Andreas Van Ginneken	ARGONNE NATIONAL LABORATORY UNIVERSITY OF CHICAGO FERMILAB
	Request	25 Jan, 74	Target Exposure(s)
	Approval	8 Jul, 74	Target Exposure(s)
		30 Aug, 76	Target Exposure(s) with different chemicals and re-exposure of two previous samples
	Completed	2 Nov, 75	3 Targets Exposed
279	EMULSION/PROTONS @ 400 #279 BEAM: Neutrino Area - Miscellaneous THE INTERACTION OF PA=PAE+E- AT 400 GEV.	David T. King	UNIVERSITY OF TENNESSEE, KNOXVILLE
	Request	28 Jan, 74	Emulsion Exposure
	Approval	12 Mar, 74	Emulsion Exposure
	Completed	9 Dec, 75	3 Stack(s)
280	30-INCH P - D @ 200 #280 BEAM: Neutrino Area - 30 in. Hadron Beam PROPOSAL TO STUDY P - D INTERACTIONS AT 205 GEV/C IN THE 30-INCH BUBBLE CHAMBER.	Thomas H. Fields	ARGONNE NATIONAL LABORATORY CIPP (CANADA) JINR, DUBNA (RUSSIA) MOSCOW STATE UNIVERSITY (RUSSIA)
	Request	1 Feb, 74	100 K Pix
	Approval	21 Mar, 74	100 K Pix in bare chamber with downstream chamber data if it can be arranged
	Completed	11 Oct, 75	103 K Pix
281	30-INCH HYBRID #281 BEAM: Neutrino Area - 30 in. Hadron Beam PROPOSAL TO STUDY HIGH ENERGY PROTON-PROTON AND PI-MINUS PROTON INTERACTIONS WITH THE NAL 30-INCH BUBBLE CHAMBER-WIDE GAP SPARK CHAMBER HYBRID SYSTEM.	Gerald A. Smith	IOWA STATE UNIVERSITY UNIVERSITY OF MARYLAND MICHIGAN STATE UNIVERSITY NOTRE DAME UNIVERSITY
	Request	1 Feb, 74	400 K Pix including 200K pix of p - p 300 GeV and 200K pix of pi- - p at highest momentum
		25 Sep, 74	700 K Pix total including 300K pix of p - p @ 300 GeV, 100K pix of pi- - p @ 100 GeV, and 300K pix of pi- - p @ 375 GeV
	Approval	22 Nov, 74	300 K Pix in a combination of pi- and p bombardments at an energy greater than or equal to 300 GeV and with the understanding that following this run work with the wide gap chamber system will be terminated
	Completed	28 Sep, 75	301 K Pix of pi- - p interactions at 360 GeV/c
284	PARTICLE PRODUCTION #284 BEAM: Proton Area - West SURVEY OF PARTICLE PRODUCTION IN PROTON COLLISIONS AT NAL. (Continuation of work begun in exp #63A.)	James K. Walker	FERMILAB NORTHEASTERN UNIVERSITY NORTHERN ILLINOIS UNIVERSITY
	Request	19 Feb, 74	Unspecified
	Approval	26 Jun, 74	750 Hours divided roughly as 150 hours for setup and testing and 150 hours each at the four energies of 100, 200, 300, and 400 GeV
	Completed	3 Oct, 76	1,150 Hours

285	SUPER-HEAVY ELEMENTS #285 BEAM: Neutrino Area - Miscellaneous A SEARCH FOR A NEW STATE OF MATTER IN THE ANALYSIS OF AN NAL BEAM DUMP.	Leon M. Lederman	COLUMBIA UNIVERSITY FERMILAB
	Request	21 Feb, 74	Target Exposure(s)
	Approval	27 Feb, 74	Target Exposure(s)
	Completed	2 Aug, 76	3 Targets Exposed
288	DI-LEPTON #288 BEAM: Proton Area - Center A STUDY OF DI-LEPTON PRODUCTION IN PROTON COLLISIONS AT NAL. (Formerly known as exp #70 III.)	Leon M. Lederman	COLUMBIA UNIVERSITY FERMILAB SUNY AT STONY BROOK
	Request	21 Feb, 74	Unspecified
		10 May, 76	1,500 Hours additional for mu-mu II
		10 Nov, 77	4,500 Hours with a request for an additional 3,000 hours for high intensity and high resolution studies
	Approval	18 Jan, 74	1,000 Hours
		17 Nov, 76	2,500 Hours with additional 1,500 hours not to extend beyond 1 Sep 1977
		16 Nov, 77	5,500 Hours with an extension of about 3,000 hours until August 1978, and with a request for a progress report in May 1978
	Completed	23 Jul, 78	6,850 Hours
289	PROTON-HELIUM SCATTERING #289 BEAM: Internal Target Area (C-0) SMALL ANGLE PROTON-HELIUM ELASTIC AND INELASTIC SCATTERING FROM 8 TO 500 GEV. (Using an internal proton beam with a gas jet target.)	Ernest I. Malamud	UNIVERSITY OF ARIZONA FERMILAB JINR, DUBNA (RUSSIA)
	Request	1 Mar, 74	700 Hours
	Approval	22 Mar, 74	700 Hours conditional upon successful development of the helium jet technique
	Completed	8 Nov, 77	1,050 Hours
290	BACKWARD SCATTERING #290 BEAM: Meson Area - M6 Beam BACKWARD PION-PROTON ELASTIC SCATTERING. (For u from 0 - 0.8.)	Winslow F. Baker	UNIVERSITY OF ARIZONA FERMILAB
	Request	6 Mar, 74	1,100 Hours including 200 hours for testing
	Approval	22 Nov, 74	900 Hours
	Completed	31 Jul, 78	1,500 Hours
292	EMULSION/PROTONS @ 400 #292 BEAM: Neutrino Area - Miscellaneous MULTIPARTICLE PRODUCTION IN NUCLEI BY PROTONS OF SEVERAL HUNDRED GEV. (Using target materials consisting of fine wires imbedded in emulsion or foils covering the emulsion; 400 GeV exposure.)	Kurt Gottfried	IAP, BUCHAREST (ROMANIA) CERN (SWITZERLAND) CORNELL UNIVERSITY UNIVERSITY OF LUND (SWEDEN)
	Request	30 Nov, 73	Emulsion Exposure
	Approval	16 Jan, 74	Emulsion Exposure
	Completed	9 Dec, 75	12 Stack(s)
295	30-INCH PI+ & P - D @ 200 #295 BEAM: Neutrino Area - 30 in. Hadron Beam A STUDY OF PI+ - D INTERACTIONS AT 200 GEV/C IN THE 30-INCH BUBBLE CHAMBER AT NAL.	Gideon Yekutieli	CRN, STRASBOURG (FRANCE) FERMILAB WEIZMANN INSTITUTE (ISRAEL)
	Request	15 Mar, 74	50 K Pix of p - d @ 205 GeV
		14 Aug, 74	150 K Pix total including an additional 50K pix due to decreased yield of pi+ - d events
	Approval	21 Mar, 74	100 K Pix in bare chamber with downstream chamber data if it can be arranged; and with request that interest be switched from p - d to pi+ - d bombardment
		27 Aug, 74	150 K Pix with additional 50K pix to yield the requested number of pi+ - d
	Completed	2 Nov, 75	156 K Pix
297	QUARK #297 BEAM: Neutrino Area - 30 in. Hadron Beam QUARK SEARCH USING 400-500 GEV PROTONS. (By measuring ionization energy loss.)	Lawrence B. Leipuner	BROOKHAVEN NATIONAL LABORATORY
	Request	15 Apr, 74	24 Hours with beam of 5 x 10 to the 4th particles/pulse and a 200 msec spill
	Approval	15 May, 74	24 Hours
	Completed	10 Jul, 74	50 Hours
299	30-INCH HYBRID #299 BEAM: Neutrino Area - 30 in. Hadron Beam PRECISION STUDY OF HIGH ENERGY COLLISIONS INDUCED BY INCIDENT 150 GEV/C PIONS AND PROTONS. (Using the downstream PNC hybrid system.)	Irwin A. Pless	BROWN UNIVERSITY UNIVERSITY OF CAMBRIDGE (ENGLAND) FERMILAB ILLINOIS INSTITUTE OF TECHNOLOGY UNIVERSITY OF ILLINOIS, CHAMPAIGN INDIANA UNIVERSITY JOHNS HOPKINS UNIVERSITY UNIVERSITY OF L'ETAT (BELGIUM) MASSACHUSETTS INST. OF TECHNOLOGY SUNY AT ALBANY NIJMEGEN UNIVERSITY (NETHERLANDS) OAK RIDGE NATIONAL LABORATORY RUTGERS UNIVERSITY STEVENS INSTITUTE OF TECHNOLOGY UNIVERSITY OF TENNESSEE, KNOXVILLE YALE UNIVERSITY
	Request	16 May, 74	1,200 K Pix at 150 GeV equally split between study of p - p, pi- - p, and pi+ - p interactions
	Approval	22 Nov, 74	600 K Pix of pi- - p, p - p, and pi+ - p interactions at 150 GeV/c
		6 Aug, 76	500 K Pix to be pi+ - p @ 150 GeV/c in 30-inch bubble chamber with PNC hybrid system and with 100K pix of pi- - p now included in approval for exp# 393
		28 Oct, 76	660 K Pix with additional 160K pix from a collaboration with proposal #375 to provide an overall package of 500K pix to be taken in an enriched K+ mode; 160K pix already taken at this time
	Completed	22 Nov, 76	431 K Pix with 229K pix remaining to be taken under earlier approval when declared complete on 29 Jun 1977

300	PARTICLE SEARCH #300 BEAM: Proton Area - East STUDY OF PARTICLE PRODUCTION AT HIGH TRANSVERSE MOMENTA USING HYDROGEN AND DEUTERIUM TARGETS.	Pierre A. Piroué	UNIVERSITY OF CHICAGO PRINCETON UNIVERSITY
	Request	16 May, 74	1,200 Hours with a liquid hydrogen/deuterium target and at beam energies of 200, 300, 400, and 500 GeV
	Approval	26 Jun, 74	600 Hours with hydrogen target
	Completed	24 Apr, 76	750 Hours
305	NEUTRON DISSOCIATION #305 BEAM: Meson Area - M3 Beam PROPOSAL TO STUDY THE COHERENT DISSOCIATION OF NEUTRONS. (A continuation of work begun in exp #27A.)	Bruno Gobbi	FERMILAB NORTHWESTERN UNIVERSITY UNIVERSITY OF ROCHESTER SLAC
	Request	22 May, 74	1,200 Hours total to include one month of running every four months through calendar 1975
	Approval	26 Jun, 74	900 Hours without approval for the installation of the transmission target for H2 and D2 cross section measurements
	Completed	16 Dec, 74 14 Apr, 75	1,200 Hours with additional 300 hours for particle search 1,400 Hours
310	NEUTRINO #310 BEAM: Neutrino Area - Wide Band Horn FURTHER STUDY OF HIGH ENERGY NEUTRINO INTERACTIONS AT FERMILAB.	David B. Cline	FERMILAB HARVARD UNIVERSITY UNIVERSITY OF PENNSYLVANIA RUTGERS UNIVERSITY UNIVERSITY OF WISCONSIN - MADISON
	Request	4 Jun, 74 1 Feb, 78	Unspecified 1,200 Hours to include 2 x 10 to the 18th protons on target with the Wide Band Horn system focused for negatives without a plug and 2 x 10 to the 18th for positives
	Approval	22 Nov, 74 17 Nov, 76 15 Mar, 77	1,000 Hours with a formal approval for 2 x 10 to the 18th protons and the understanding that use will be made of a horn focusing system 1,000 Hours to also include running with the Quadrupole Triplet train for an exposure of 1 x 10 to the 18th protons during December 1976 2,500 Hours with formal additional approval as follows--1 - 2 x 10 to the 18th protons using the sign-selected-bare-target train understood to focus antineutrinos, and 2 x 10 to the 18th protons using the Quadrupole Triplet train load
	Completed	21 Mar, 78 31 Aug, 78	3,500 Hours with additional approval for a final run to complete the experiment during wide-band horn running for the 15-ft bubble chamber 3,800 Hours at the request of the experimenters, because it was felt that the conditions required to properly continue the experiment could not be met.
311	30-INCH PBAR - P @ 100 #311 BEAM: Neutrino Area - 30 in. Hadron Beam PROPOSAL TO STUDY MULTIPARTICLE PRODUCTION IN HIGH ENERGY ANTIPROTON-PROTON INTERACTIONS WITH THE FERMILAB 30-INCH BUBBLE CHAMBER.	William W. Neale	UNIVERSITY OF CAMBRIDGE (ENGLAND) FERMILAB MICHIGAN STATE UNIVERSITY
	Request	6 Jun, 74	100 K Pix with equal numbers of pbar and pi-
	Approval	26 Jun, 74	100 K Pix to be obtained with not more than 200K pulses of the chamber
	Completed	27 Jan, 75	98 K Pix
313	PROTON-PROTON POLARIZATION #313 BEAM: Internal Target Area (C-0) POLARIZATION IN P - P ELASTIC, INELASTIC AND INCLUSIVE REACTIONS AT FERMILAB ENERGIES. (Using a gas jet target with hydrogen, the internal proton beam, the spectrometer of exp #198A, and a new carbon polarimeter.)	Homer A. Neal	INDIANA UNIVERSITY
	Request	5 Jun, 74	1,500 Hours total with two jet pulses per cycle
	Approval	26 Jun, 74	1,000 Hours with about 800 hours of running on polarization in elastic scattering and about 200 hours of running to observe polarization in inelastic channels
	Completed	15 Mar, 77 30 Mar, 77	1,000 Hours with encouragement to use some of the remaining running to accumulate further data on polarization in inelastic processes; see proposal #522 850 Hours with some approved running remaining; see exp #522
317	PROTON-NUCLEON INELASTIC #317 BEAM: Internal Target Area (C-0) PROTON DIFFRACTION DISSOCIATION ON HYDROGEN AND DEUTERIUM. (Using the gas jet target and internal proton beam.)	Rodney L. Cool	UNIVERSITY OF ARIZONA FERMILAB JINR, DUBNA (RUSSIA) UNIVERSITY OF ROCHESTER ROCKEFELLER UNIVERSITY
	Request	7 Jun, 74	800 Hours for tests and data taking
	Approval	3 Jul, 74	800 Hours using gas jet with running to be interleaved with exp# 321
	Completed	1 Nov, 75	1,400 Hours
319	MUON #319 BEAM: Neutrino Area - Muon/Hadron Beam FURTHER TEST OF SCALING AT HIGH MOMENTUM TRANSFERS IN DEEP INELASTIC MUON SCATTERING. (A continued exploration of the studies begun in exp #26.)	K. Wendell Chen	FERMILAB MICHIGAN STATE UNIVERSITY
	Request	10 Jun, 74	1,100 Hours
	Approval	26 Mar, 75	500 Hours for a scaling test at high energies
	Completed	20 Sep, 76	900 Hours
320	NEUTRINO #320 BEAM: Neutrino Area - Dichromatic PROPOSAL TO MEASURE NEUTRAL CURRENT CROSS-SECTIONS AND ASSOCIATED INELASTIC DISTRIBUTIONS IN THE NARROW-BAND BEAM.	Frank J. Sciulli	CALIFORNIA INSTITUTE OF TECHNOLOGY FERMILAB
	Request	10 Jun, 74	1,200 Hours with request of 3 x 10 to the 18th protons total and initial run of 1 x 10 to the 18th protons for investigation
	Approval	26 Jun, 74	500 Hours with a formal approval for 1 x 10 to the 18th protons pending a positive finding of neutral currents and with the inclination to assign higher priority for running to exp# 320 than to completion of exp# 21
	Completed	1 Oct, 74	500 Hours

321	PROTON-PROTON INELASTIC #321 BEAM: Internal Target Area (C-0) A HIGH PRECISION EXPERIMENT TO MEASURE THE INELASTIC P - P CROSS SECTION AND ITS ASSOCIATED FORWARD MULTIPLICITIES AT SMALL MOMENTUM TRANSFER. (Using a new hydrogen gas jet target and the internal proton beam.)	Juliet Lee-Franzini	COLUMBIA UNIVERSITY SUNY AT STONY BROOK
	Request	11 Jun, 74	2,000 Hours total including 800 hours for testing
	Approval	3 Jul, 74	800 Hours with running to be interleaved with exp# 317 and using the existing cryogenic hydrogen jet
	Completed	26 Mar, 75 20 Sep, 76	800 Hours with approval to use a room temperature gas jet of their own design 1,900 Hours
324	INCLUSIVE SCATTERING #324 BEAM: Meson Area - M1 Beam A PROPOSAL TO STUDY SINGLE PARTICLE INCLUSIVE SPECTRA IN HIGH ENERGY HADRON-HADRON COLLISIONS	Howard L. Weisberg	UNIVERSITY OF PENNSYLVANIA
	Request	11 Apr, 74	1,000 Hours
	Approval	24 Jun, 74	500 Hours
	Completed	13 Aug, 77	1,200 Hours
325	PARTICLE SEARCH #325 BEAM: Proton Area - East STUDY OF DI-MUON PRODUCTION AT HIGH TRANSVERSE MOMENTA.	Pierre A. Piroué	UNIVERSITY OF CHICAGO PRINCETON UNIVERSITY
	Request	12 Jun, 74	Parasitic Running
	Approval	25 Nov, 74	Parasitic Running with the stipulation that this running time will be concurrent with the previously approved 600 hours for exp# 300
		6 May, 76	600 Hours for a portion of the program estimated to require 13 weeks and with the expectation to continue the experiment during another running period
	Completed	26 Oct, 76 28 Feb, 77	1,200 Hours during a six-week running period to begin in January 1977 1,500 Hours
326	DI-MUON #326 BEAM: Proton Area - West PROPOSAL TO MEASURE MUON PAIRS PRODUCED AT HIGH TRANSVERSE MOMENTUM BY PIONS.	Melvyn Jay Shochet	UNIVERSITY OF CHICAGO PRINCETON UNIVERSITY
	Request	29 May, 74	Unspecified
		7 Jul, 75	400 Hours
		2 Feb, 77	800 Hours to be run in conjunction with exp #258 in the P-West pion beam by adding a second arm to the exp #258 spectrometer
	Approval	15 Mar, 77	800 Hours
	Completed	26 Apr, 82	2,000 Hours
327	DETECTOR DEVELOPMENT #327 BEAM: Neutrino Area - Miscellaneous PROPOSAL TO TEST PARTICLE IDENTIFICATION BY IONIZATION LOSS (ISIS).	Wade W. M. Allison	MASSACHUSETTS INST. OF TECHNOLOGY UNIVERSITY OF OXFORD (ENGLAND)
	Request	15 Jul, 74	400 Hours
	Approval	31 Jul, 74	50 Hours
	Completed	7 Feb, 75	50 Hours
328	EMULSION/PI- @ 200 #328 BEAM: Neutrino Area - Miscellaneous PROPOSAL TO STUDY THE INTERACTIONS OF PI- MESONS IN NUCLEAR EMULSION AT THE FERMILAB ACCELERATOR.	M. I. Tretjakova	LEBEDEV PHYSICAL INST. (RUSSIA)
	Request	5 Aug, 74	Emulsion Exposure
	Approval	5 Aug, 74	Emulsion Exposure
	Completed	7 Oct, 74	5 Stack(s)
329	EMULSION/PROTONS @ 300 #329 BEAM: Neutrino Area - Miscellaneous PROPOSAL TO STUDY THE INTERACTIONS OF PROTONS IN NUCLEAR EMULSION AT THE FERMILAB ACCELERATOR.	M. I. Tretjakova	LEBEDEV PHYSICAL INST. (RUSSIA)
	Request	5 Aug, 74	Emulsion Exposure
	Approval	3 Jun, 75	Emulsion Exposure
	Completed	10 Jun, 75	2 Stack(s)
330	PARTICLE SEARCH #330 BEAM: Meson Area - M4 Beam SEARCH FOR MASSIVE NEUTRAL PARTICLES. (Using time-of-flight and a total absorption calorimeter.)	H. Richard Gustafson	UNIVERSITY OF MICHIGAN - ANN ARBOR
	Request	6 Aug, 74	1,300 Hours to include 800 hours for tuneup parasitic to exp #305 and 500 hours for data
	Approval	22 Jan, 75	100 Hours
	Completed	7 Jul, 75	150 Hours
331	DI-MUON #331 BEAM: Neutrino Area - Muon/Hadron Beam PROPOSAL FOR A DETAILED STUDY OF DI-MUON PRODUCTION. (Alternative version of expts #308 & #323 designed for muon laboratory cyclotron spectrometer.)	James E. Pilcher	UNIVERSITY OF CHICAGO PRINCETON UNIVERSITY
	Request	10 Aug, 74	Unspecified
	Approval	25 Nov, 74	400 Hours for an initial run at an incident beam intensity of about 10 to the 6th particles/pulse
	Completed	22 Mar, 76	1,400 Hours
335	MUON SEARCH #335 BEAM: Meson Area - M1 Beam A SEARCH FOR DIRECT MUON PRODUCTION IN THE FORWARD DIRECTION.	Orrin D. Fackler	CALIFORNIA INSTITUTE OF TECHNOLOGY UNIVERSITY OF CHICAGO FERMILAB PRINCETON UNIVERSITY ROCKEFELLER UNIVERSITY
	Request	18 Aug, 74	200 Hours total including time for tests and data
	Approval	22 Nov, 74	200 Hours provided that this running time can be arranged in such a way as not to interfere substantially with the ongoing physics program in the M1 beam line
	Completed	6 Jun, 75	300 Hours

336	EMULSION/PROTONS @ 400 #336 BEAM: Neutrino Area - Miscellaneous MULTIPARTICLE PRODUCTION IN NUCLEON-NUCLEUS COLLISIONS AT 400 GEV. +-----+ Request 9 Sep, 74 Emulsion Exposure Approval 19 Oct, 74 Emulsion Exposure Completed 9 Dec, 75 2 Stack(s)	Takeshi Ogata	KWANSEI GAKUIN UNIVERSITY (JAPAN)
337	DI-MUON #337 BEAM: Meson Area - Miscellaneous MEASUREMENT OF DI-MUON EVENTS IN THE MESON AREA. +-----+ Request 20 Sep, 74 3 Hours Approval 27 Sep, 74 3 Hours Completed 7 Feb, 75 5 Hours	David P. Eartly	FERMILAB MAX-PLANCK INSTITUTE (GERMANY)
338	30-INCH PI- - D @ 360 #338 BEAM: Neutrino Area - 30 in. Hadron Beam PION-DEUTERON INTERACTIONS AT 400 GEV/C. +-----+ Request 21 Sep, 74 100 K Pix Approval 24 Sep, 74 50 K Pix in bare chamber with downstream chamber data if it can be arranged Completed 28 Aug, 76 53 K Pix	Keihachiro Moriyasu	UNIV. OF CALIFORNIA, DAVIS INP, KRAKOW (POLAND) WARSAW UNIVERSITY, INP, (POLAND) UNIVERSITY OF WASHINGTON
339	EMULSION/PI- @ 200 #339 BEAM: Neutrino Area - Miscellaneous CRACOW EMULSION EXPOSURE TO 200 GEV PIONS. +-----+ Request 12 Sep, 74 Emulsion Exposure Approval 1 Oct, 74 Emulsion Exposure Completed 9 Jun, 75 4 Stack(s)	Wladyslaw Wolter	INP, KRAKOW (POLAND)
340	EMULSION/ELECTRONS @ HI E #340 BEAM: Proton Area - Miscellaneous STUDY OF THE ELECTRON-PHOTON CASCADE SHOWER IN LEAD ABSORBER. +-----+ Request 25 Sep, 74 Emulsion Exposure Approval 10 Oct, 74 Emulsion Exposure Completed 5 Oct, 76 10 Stack(s)	Shoji Dake	KOBE UNIVERSITY (JAPAN) KONAN UNIVERSITY (JAPAN) SAITAMA UNIVERSITY (JAPAN) UNIVERSITY OF TOKYO (JAPAN) UTSUNOMIYA UNIVERSITY (JAPAN) WASEDA UNIVERSITY (JAPAN)
341	15-FOOT P - P @ 400 #341 BEAM: Neutrino Area - 15 ft. Hadron Beam INTERACTIONS OF PI+ MESONS AND PROTONS IN A HYDROGEN-NEON MIXTURE. +-----+ Request 1 Oct, 74 100 K Pix Approval 4 Dec, 74 25 K Pix of tagged pi+ and p at 150 GeV in H2 to develop analysis techniques for 15-foot bubble chamber film Completed 8 Dec, 75 25 K Pix of p - p interactions at 400 GeV 21 Dec, 75 34 K Pix	Winston Ko	UNIV. OF CALIFORNIA, DAVIS LAWRENCE BERKELEY LABORATORY
343	15-FOOT P - P @ 300 #343 BEAM: Neutrino Area - 15 ft. Hadron Beam PROPOSAL TO STUDY NEUTRAL PARTICLE PRODUCTION IN 250 GEV P - P INTERACTIONS IN THE FERMILAB 15-FOOT BUBBLE CHAMBER. +-----+ Request 3 Oct, 74 25 K Pix Approval 4 Dec, 74 25 K Pix Completed 13 Jan, 76 27 K Pix	Roderich J. Engelmann	ARGONNE NATIONAL LABORATORY UNIVERSITY OF KANSAS SUNY AT STONY BROOK TUFTS UNIVERSITY
344	30-INCH PBAR - P @ 50 #344 BEAM: Neutrino Area - 30 in. Hadron Beam PROPOSAL TO SURVEY CENTRAL COLLISIONS IN PBAR - P TO MESONS BETWEEN 30 AND 60 GEV/C IN THE 30-INCH BUBBLE CHAMBER AT FERMILAB. +-----+ Request 4 Oct, 74 100 K Pix to be taken in < 200K chamber expansions Approval 27 Nov, 74 100 K Pix with the qualification that it must be possible to obtain these pictures in no more than one calendar month of running time Completed 1 Nov, 76 145 K Pix	Laszlo J. Gutay	CNTRL RES INST, BUDAPEST (HUNGARY) FERMILAB PURDUE UNIVERSITY
345	30-INCH PBAR - D @ 100 #345 BEAM: Neutrino Area - 30 in. Hadron Beam PROPOSAL TO STUDY MULTIPARTICLE PRODUCTION IN 100 GEV/C ANTI-PROTON-DEUTERIUM INTERACTIONS WITH THE FERMILAB 30-INCH BUBBLE CHAMBER. +-----+ Request 5 Oct, 74 100 K Pix with a Cerenkov tagged incoming beam Approval 4 Dec, 74 100 K Pix with the qualification that serious consideration be given to the use* of the PWC downstream system Completed 7 Sep, 76 61 K Pix with 39K pix remaining to be taken under earlier approval when declared complete on 29 Jun 1977	Gosta Ekspong	UNIVERSITY OF LIVERPOOL (ENGLAND) UNIVERSITY OF STOCKHOLM (SWEDEN) VANDERBILT UNIVERSITY
346	EMULSION/PROTONS @ 400 #346 BEAM: Neutrino Area - Miscellaneous SEARCH FOR HEAVY, SHORTLIVED PARTICLES. +-----+ Request 6 Oct, 74 Emulsion Exposure Approval 21 Oct, 74 Emulsion Exposure Completed 9 Dec, 75 1 Stack(s)	Gosta Ekspong	UNIVERSITY OF STOCKHOLM (SWEDEN)
350	INCLUSIVE NEUTRAL MESON #350 BEAM: Meson Area - M2 Beam A PROPOSAL TO STUDY NEUTRAL PIONS AND MESON INCLUSIVE PRODUCTION WITH INCIDENT NEGATIVE PIONS IN THE TRIPLE REGGE REGION. (Using the photon detector of exp #111.) +-----+ Request 11 Oct, 74 500 Hours Approval 21 Nov, 74 400 Hours 16 Dec, 74 400 Hours with up to 150 hours approved for a particle search with the condition that this time be included within the 900 hours already approved for for exps# 268 and 350 Completed 24 Feb, 77 900 Hours	Robert W. Kenney	BROOKHAVEN NATIONAL LABORATORY CALIFORNIA INSTITUTE OF TECHNOLOGY LAWRENCE BERKELEY LABORATORY

356	NEUTRINO #356 BEAM: Neutrino Area - Dichromatic STUDIES OF DEEP INELASTIC DIFFERENTIAL DISTRIBUTIONS AT HIGH ENERGIES FOR NEUTRINO AND ANTI-NEUTRINO BEAMS. (A continuation of the work begun in exp #21A with a new narrow band beam and changed apparatus.)	Frank J. Sciulli	CALIFORNIA INSTITUTE OF TECHNOLOGY FERMILAB UNIVERSITY OF ROCHESTER ROCKEFELLER UNIVERSITY
	Request	18 Oct, 74	1,000 Hours
	Approval	22 Nov, 74	1,000 Hours with a formal commitment of 2×10^{10} to the 18th protons contingent on the feasibility of developing the improved Dichromatic beam
	Completed	17 Jan, 79	1,350 Hours
357	PARTICLE SEARCH #357 BEAM: Meson Area - M2 Beam A PROPOSAL TO SEARCH FOR CHARMED PARTICLES AND MEASUREMENTS OF TWO-PARTICLE INCLUSIVE CROSS SECTIONS AT LARGE P-TRANSVERSE. (Employing a two-arm magnetic spectrometer.)	Donald I. Meyer	FERMILAB UNIVERSITY OF MICHIGAN - ANN ARBOR PURDUE UNIVERSITY
	Request	19 Oct, 74	2,400 Hours
	Approval	16 Dec, 74	600 Hours
	Completed	7 Jun, 76	1,700 Hours
358	DI-MUON #358 BEAM: Proton Area - East DI-MUON PRODUCTION BY NEUTRONS.	Wonyong Lee	COLUMBIA UNIVERSITY CORNELL UNIVERSITY FERMILAB UNIVERSITY OF HAWAII AT MANOA UNIVERSITY OF ILLINOIS, CHAMPAIGN
	Request	20 Oct, 74	Unspecified
	Approval	27 Nov, 74	300 Hours of neutron running to be interleaved within the 600 hours already approved for exp# 87A
	Completed	1 Oct, 75	400 Hours
361	LAMBDA BETA-DECAY #361 BEAM: Meson Area - M2 Beam PRECISION MEASUREMENT OF LAMBDA BETA DECAY PARAMETERS. (Will run with experimental set-up for neutral hyperon #8.)	Lee G. Pondrom	UNIVERSITY OF MICHIGAN - ANN ARBOR UNIVERSITY OF MINNESOTA RUTGERS UNIVERSITY UNIVERSITY OF WISCONSIN - MADISON
	Request	14 Nov, 74	300 Hours
		23 Jan, 76	350 Hours total including 150 hours in unpolarized lambda-zero beam and 200 hours in polarized lambda-zero beam
	Approval	15 Nov, 77	300 Hours
	Completed	29 Oct, 79	1,250 Hours
362	EMULSION/PI- @ 200 #362 BEAM: Neutrino Area - Miscellaneous INTERACTION OF 200 - 400 GEV PIONS WITH EMULSION NUCLEI.	Piyare L. Jain	SUNY AT BUFFALO
	Request	15 Nov, 74	Emulsion Exposure
	Approval	25 Nov, 74	Emulsion Exposure
	Completed	9 Jun, 75	1 Stack(s)
363	PARTICLE SEARCH #363 BEAM: Internal Target Area (C-0) A PROPOSAL TO SEARCH FOR CHARMED PARTICLE PRODUCTION NEAR THRESHOLD.	Stephen L. Olsen	FLORIDA STATE UNIVERSITY IMPERIAL COLLEGE (ENGLAND) UNIVERSITY OF ROCHESTER RUTGERS UNIVERSITY
	Request	24 Nov, 74	Unspecified
	Approval	16 Dec, 74	500 Hours of running with the rotating carbon filament target
	Completed	9 Apr, 75	650 Hours
365	PARTICLE SEARCH #365 BEAM: Meson Area - M2 Beam A PROPOSAL TO SEARCH FOR THE PRODUCTION OF CHARMED MESONS IN PI - P INTERACTIONS.	David A. Garelick	NORTHEASTERN UNIVERSITY
	Request	27 Nov, 74	200 Hours including 40 hours for testing
	Approval	31 Dec, 74	200 Hours during a two week run with a passive, nonmagnetized steel absorber to be used in conjunction with a muon trigger
	Completed	5 Feb, 75	200 Hours
366	PARTICLE SEARCH #366 BEAM: Meson Area - M3 Beam STUDY OF HEAVY, NARROW MESONS USING A MASS-FOCUSING SPECTROMETER. (Experiment consists mainly of rearranged components from exp #12.)	Maris A. Abolins	CARELTON UNIVERSITY (CANADA) FERMILAB MICHIGAN STATE UNIVERSITY OHIO STATE UNIVERSITY
	Request	27 Nov, 74	Unspecified
	Approval	16 Dec, 74	600 Hours for a particle search to be slanted particularly toward an identification of charmed mesons
		24 Nov, 75	1,200 Hours with an additional 600 hours to explore the possibility of a mass peak in the K- pi+ mass spectrum
	Completed	2 Jul, 76	2,500 Hours
369	PARTICLE SEARCH #369 BEAM: Neutrino Area - Muon/Hadron Beam A SEARCH FOR CHARMED PARTICLES. (Using the spectrometer originally developed for exp #98.)	Thomas B. W. Kirk	FERMILAB HARVARD UNIVERSITY UNIVERSITY OF ILLINOIS, CHAMPAIGN MAX-PLANCK INSTITUTE (GERMANY) TUFTS UNIVERSITY
	Request	9 Dec, 74	700 Hours for data with 300 pulses/hour and 1×10^{10} to the 6th pi-/pulse
	Approval	17 Mar, 76	600 Hours
	Completed	13 Aug, 77	1,000 Hours
370	NEUTRINO #370 BEAM: Neutrino Area - Quadrupole Triplet CONTINUED SEARCH FOR NEW PARTICLE PRODUCTION USING THE EXP #1A DETECTOR.	David B. Cline	FERMILAB HARVARD UNIVERSITY UNIVERSITY OF PENNSYLVANIA UNIVERSITY OF WISCONSIN - MADISON
	Request	9 Dec, 74	500 Hours with a total of 1×10^{10} to the 18th protons and a 1 msec spill
	Approval	7 Jul, 75	500 Hours with the hope of providing 1×10^{10} to the 18th protons
	Completed	19 Mar, 75	400 Hours

371	SUPER-HEAVY ELEMENTS #371 BEAM: Meson Area - Miscellaneous INVESTIGATION OF THE PRODUCTION OF HEAVY FRAGMENTS INDUCED BY PARTICLES OF HIGH ENERGIES.	Mira Juric	UNIVERSITY OF BELGRADE (YUGOSLAVIA)
	Request	2 Dec, 74	Target Exposure(s)
	Approval	12 Mar, 75	Target Exposure(s)
	Completed	20 Dec, 75	2 Stack(s)
373	EMULSION/MUONS @ 200 #373 BEAM: Neutrino Area - Miscellaneous INTERACTION OF 50 - 100 GEV MUONS WITH EMULSION NUCLEI.	Piyare L. Jain	SUNY AT BUFFALO
	Request	8 Jul, 75	Emulsion Exposure
	Approval	24 Sep, 76	Emulsion Exposure to muons @ 225 GeV/c and with an intensity not to exceed 50K particles/sq cm
	Completed	22 Nov, 76	2 Stack(s)
374	EMULSION/PROTONS @ 300 #374 BEAM: Neutrino Area - Miscellaneous A PROPOSAL TO SEARCH FOR CHARMED PARTICLES ORIGINATING FROM INTERACTIONS OF 300 GEV/C PROTONS IN EMULSION NUCLEI.	D. H. Davis	UNIVERSITY OF BELGRADE (YUGOSLAVIA) UNIV. COLLEGE DUBLIN (IRELAND) INP, KRAKOW (POLAND) UNIVERSITY OF LIBRE (BELGIUM) LONDON UNIVERSITY COLLEGE (ENGLAND) THE OPEN UNIVERSITY (ENGLAND) INFN, ROME (ITALY) UNIVERSITY OF STRASBOURG (FRANCE) WARSAW UNIVERSITY, INP, (POLAND)
	Request	25 Jan, 74	Emulsion Exposure
	Approval	12 Mar, 75	Emulsion Exposure with the understanding that exp# 374 will replace exp# 364
	Completed	10 Jun, 75	1 Stack(s)
379	PARTICLE SEARCH #379 BEAM: Neutrino Area - 15 ft. Hadron Beam SEARCH FOR SHORT LIVED STATES DECAYING WEAKLY VIA LEPTONIC MODES.	Stanley G. Wojcicki	CALIFORNIA INSTITUTE OF TECHNOLOGY UNIVERSITY OF ROCHESTER STANFORD UNIVERSITY
	Request	5 Feb, 75	1,000 Hours
	Approval	26 Mar, 75	200 Hours for testing and initial data taking
		17 Nov, 76	600 Hours with 400 hours for high priority running and with the expectation that a second 400 hour run will be approved if preliminary analysis of initial results are satisfactory
		15 Mar, 77	600 Hours with a hope of combining the two requested running periods into a single block of running but with the understanding that the total number of hours would be somewhat less than requested
	Completed	8 Jun, 77	1,250 Hours
380	15-FOOT NEUTRINO/H2&NE #380 BEAM: Neutrino Area - Dichromatic STUDY OF THE PROPERTIES OF WEAK NEUTRAL CURRENTS IN THE INTERACTIONS OF A NARROW BAND NEUTRINO BEAM IN LIQUID NEON.	Charles Baltay	BROOKHAVEN NATIONAL LABORATORY COLUMBIA UNIVERSITY
	Request	6 Feb, 75	200 K Pix
	Approval	7 Jul, 75	200 K Pix in a heavy neon-hydrogen mixture contingent upon the construction and adequate performance of an improved narrow-band beam
		24 Jun, 77	200 K Pix at higher energies using the D C Dichromatic train; new requests for use of the Dichromatic horn to be considered later
	Completed	31 Oct, 79	196 K Pix
381	PROTON-NUCLEON SCATTERING #381 BEAM: Internal Target Area (C-0) MEASUREMENT OF THE REAL PART OF THE P - N AND P - P FORWARD SCATTERING AMPLITUDES; PRODUCTION OF LOW MASS ISOBARS IN THE VERY SMALL MOMENTUM TRANSFER REGION. (Uses gas jet target.)	Ernest I. Malamud	UNIVERSITY OF ARIZONA FERMILAB JINR, DUBNA (RUSSIA) UNIVERSITY OF ROCHESTER
	Request	20 Feb, 75	300 Hours
	Approval	26 Mar, 75	300 Hours
	Completed	30 Mar, 77	600 Hours
382	PARTICLE SEARCH #382 BEAM: Neutrino Area - Muon/Hadron Beam A SEARCH FOR CHARMED HADRONS PRODUCED BY MUON DEEP INELASTIC SCATTERING IN TAGGED NUCLEAR EMULSIONS. (Using drift chambers to locate events and reduce scanning time.)	Louis N. Hand	CORNELL UNIVERSITY FERMILAB INP, KRAKOW (POLAND) MICHIGAN STATE UNIVERSITY UNIVERSITY OF WASHINGTON
	Request	21 Feb, 75	Emulsion Exposure
	Approval	26 Mar, 75	Emulsion Exposure with a provision that it does not seriously interfere with the rest of the muon and neutrino program
		24 Nov, 75	Emulsion Exposure with a bombardment of five days duration during December 1975
	Completed	19 Dec, 75	200 Hours
383	INCLUSIVE K-SHORT #383 BEAM: Meson Area - M4 Beam A PROPOSAL TO STUDY THE INCLUSIVE PRODUCTION OF K ZERO SHORT BY K MINUS ON HYDROGEN. (To use the M4 line as a charged beam at momenta of 20 - 150 GeV/c.)	Hans G. E. Kobrak	UNIV. OF CALIFORNIA, DAVIS UNIV. OF CALIFORNIA, SAN DIEGO CARELTON UNIVERSITY (CANADA) MICHIGAN STATE UNIVERSITY
	Request	24 Feb, 75	500 Hours
	Approval	29 Jun, 76	500 Hours with 200 hours for setup and original run and 300 hours for final run
	Completed	7 May, 78	2,200 Hours
385	EMULSION/PROTONS @ 400 #385 BEAM: Neutrino Area - Miscellaneous PROPOSAL FOR EXPOSURE OF A STACK OF NUCLEAR EMULSIONS TO PROTONS OF 400 GEV/C.	Yog Prakash	DELHI UNIVERSITY (INDIA) JAMMU UNIVERSITY (INDIA) PANJAB UNIVERSITY (INDIA) RAJASTHAN UNIVERSITY (INDIA)
	Request	5 Mar, 75	Emulsion Exposure
	Approval	11 Mar, 75	Emulsion Exposure
	Completed	9 Dec, 75	1 Stack(s)

386	EMULSION/NEW PARTICLES #386 BEAM: Neutrino Area - Miscellaneous A SEARCH FOR LOW ENERGY NEUTRAL PARTICLES AND PARTICLE INTERACTIONS INVOLVING SMALL ENERGY EXCHANGES IN THE NEUTRINO BEAM.	Jere J. Lord	UNIVERSITY OF WASHINGTON
	Request	7 Mar, 75	Emulsion Exposure
	Approval	27 Mar, 75	Emulsion Exposure
	Completed	29 Dec, 76	1 Stack(s)
387	EMULSION/PI- @ 200 #387 BEAM: Neutrino Area - Miscellaneous 100 TO 300 GEV PION INTERACTIONS IN EMULSION AND HEAVY ELEMENT TARGETS.	Richard J. Wilkes	UNIVERSITY OF WASHINGTON
	Request	7 Mar, 75	Emulsion Exposure
	Approval	13 May, 75	Emulsion Exposure
	Completed	9 Jun, 75	4 Stack(s)
388	15-FOOT ANTI-NEUTRINO/H2&NE#388 BEAM: Neutrino Area - Dichromatic PROPOSAL TO STUDY NEUTRAL CURRENT NEUTRINO AND ANTI-NEUTRINO INTERACTIONS IN THE 15-FOOT BUBBLE CHAMBER USING THE EXTERNAL MUON IDENTIFIER AND A DICHROMATIC BEAM.	Vincent Z. Peterson	FERMILAB UNIVERSITY OF HAWAII AT MANOA LAWRENCE BERKELEY LABORATORY
	Request	24 Apr, 75	200 K Pix
		7 Jun, 78	500 K Pix or 5 x 10 to the 18th protons
	Approval	7 Jul, 75	200 K Pix of antineutrino bombardment with a heavy neon-hydrogen mixture contingent upon the construction and adequate performance of an improved narrow-band beam; see proposal #455
		24 Jun, 77	200 K Pix at higher energies using the D C Dichromatic train; new requests for use of the Dichromatic horn to be considered later
	Completed	28 Jun, 78	200 K Pix with a decision to maintain the approval as it stands
		12 Sep, 79	181 K Pix
390	15-FOOT ANTI-NEUTRINO/D2 #390 BEAM: Neutrino Area - Wide Band Horn ANTI-NEUTRINO INTERACTIONS IN THE DEUTERIUM-FILLED 15-FOOT BUBBLE CHAMBER.	Arthur F. Garfinkel	ARGONNE NATIONAL LABORATORY CARNEGIE-MELLON UNIVERSITY PURDUE UNIVERSITY
	Request	29 Apr, 75	300 K Pix
	Approval	7 Jul, 75	300 K Pix
		28 Jun, 78	300 K Pix with a total of 150K pix presently scheduled for the experiment during the fall 1978 run
		19 Mar, 79	250 K Pix
	Approved/Inactive	1 Apr, 79	10 K Pix as of 1 Apr 1979
391	MUON #391 BEAM: Neutrino Area - Muon/Hadron Beam EXPLORATION OF RARE MUON-INDUCED PROCESSES.	Leroy T. Kerth	UNIV. OF CALIFORNIA, BERKELEY FERMILAB LAWRENCE BERKELEY LABORATORY PRINCETON UNIVERSITY
	Request	15 Feb, 75	Unspecified
	Approval	7 Jul, 75	Parasitic Running concurrent with exp# 203
	Completed	18 May, 78	Unspecified but for information on the total extent of run, see exp #203A
395	HADRON JETS #395 BEAM: Meson Area - M2 Beam CALORIMETER-ARRAY STUDY OF HIGH P-TRANSVERSE EVENTS.	Walter Selove	LEHIGH UNIVERSITY UNIVERSITY OF PENNSYLVANIA UNIVERSITY OF WISCONSIN - MADISON
	Request	21 May, 75	450 Hours total including 150 hours of tests
	Approval	7 Jul, 75	450 Hours contingent upon the successful completion of the calorimeter tests planned for the M5 beam line
	Completed	16 Nov, 77	1,150 Hours
396	HADRON DISSOCIATION #396 BEAM: Meson Area - M6 Beam ELASTIC SCATTERING AND DIFFRACTION DISSOCIATION AT SMALL MOMENTUM TRANSFER FOR PI ⁺ , K ⁺ , P, PBAR AND N.	Konstantin Goulianos	ROCKEFELLER UNIVERSITY
	Request	21 May, 75	1,000 Hours
	Approval	7 Jul, 75	600 Hours for Phase I
	Completed	23 Nov, 77	1,200 Hours
397	PARTICLE SEARCH #397 BEAM: Meson Area - M3 Beam PROPOSAL TO SEARCH FOR HIGH MASS PARTICLES PRODUCED IN ASSOCIATION WITH PROMPT MUONS. (Using the spectrometer from exps #27A and #305 with additions.)	Jerome L. Rosen	FERMILAB NORTHWESTERN UNIVERSITY UNIVERSITY OF ROCHESTER SLAC
	Request	21 May, 75	1,000 Hours
	Approval	9 Jul, 75	500 Hours
		18 May, 76	1,000 Hours including an additional running period of approximately 5 weeks duration during the summer of 1976
	Completed	18 Aug, 76	1,150 Hours
398	MUON #398 BEAM: Neutrino Area - Muon/Hadron Beam A PROPOSAL FOR A FURTHER STUDY OF MUON NUCLEON INELASTIC SCATTERING AT FERMILAB. (Using the spectrometer of exp #98.)	Richard Wilson	UNIVERSITY OF CHICAGO HARVARD UNIVERSITY UNIVERSITY OF ILLINOIS, CHAMPAIGN UNIVERSITY OF OXFORD (ENGLAND) VIRGINIA TECH
	Request	21 May, 75	800 Hours
	Approval	7 Jul, 75	800 Hours of H2 and D2 running with the expectation that some of this running can occur concurrently with exp #319, at which time priority will be given to exp# 319
	Completed	1 Dec, 76	1,100 Hours
399	EMULSION/ELECTRONS @ >100 #399 BEAM: Proton Area - Miscellaneous PRODUCTION OF ELECTROMAGNETIC CASCADE SHOWERS BY SEVERAL HUNDRED GEV ELECTRONS IN EMULSION CHAMBERS.	Robert L. Golden	JOHNSON SPACE CENTER (NASA) KANAGAWA UNIVERSITY (JAPAN) ISAS, TOKYO UNIVERSITY (JAPAN) UNIVERSITY OF WASHINGTON
	Request	5 May, 75	1,000 Emulsion Exposure
	Approval	19 Jun, 75	Emulsion Exposure to electrons with fluxes of 10, 1,000, and 200K/sq cm
	Completed	5 Oct, 76	6 Stack(s)

400	PARTICLE SEARCH #400 BEAM: Proton Area - East A SEARCH FOR NEW PARTICLES PRODUCED IN ASSOCIATION WITH THE HADRONIC PRODUCTION OF PSI (3.1) MESONS. (Using a proton beam of about 10 to the 7th into the zero degree neutral beam line and the spectrometer of exp #401/458 with additions.)	James E. Wiss	UNIVERSITY OF BOLOGNA (ITALY) UNIVERSITY OF COLORADO AT BOULDER FERMILAB UNIVERSITY OF ILLINOIS, CHAMPAIGN INFN, MILANO (ITALY) UNIVERSITY OF MILANO (ITALY) UNIVERSITY OF PAVIA (ITALY) YALE UNIVERSITY
	Request	22 May, 75	870 Hours
	Approval	7 Jul, 75	400 Hours
		2 Jul, 76	400 Hours with a total of 1,000 hours approved for the combination of exps #400, #401, and #458
		14 Mar, 77	400 Hours with a total of 2,000 hours for the combination of exps #400, 401 & 458
		1 Apr, 78	Unspecified since approved running time has been used by exp #87A
		7 Jul, 80	500 Hours
	Completed	14 Jul, 84	2,210 Hours
401	PHOTOPRODUCTION #401 BEAM: Proton Area - East PHOTOPRODUCTION OF HIGH MASS TWO-BODY FINAL STATES. (Using an improved exp #87A apparatus and an additional sweeping magnet in the photon beam.)	Michael F. Gormley	FERMILAB UNIVERSITY OF ILLINOIS, CHAMPAIGN
	Request	22 May, 75	300 Hours
		1 Jun, 78	1,100 Hours
	Approval	7 Jul, 75	300 Hours
		2 Jul, 76	300 Hours with a total of 1,000 hours approved for the combination of exps #400, #401, and #458
		14 Mar, 77	600 Hours with a total of 2,000 hours for the combination exps #400, 401, & 458
		1 Apr, 78	Unspecified since approved running time has been used by exp #87A
		29 Jun, 78	600 Hours
	Completed	26 Nov, 79	2,100 Hours
404	INCLUSIVE NEUTRON #404 BEAM: Meson Area - M2 Beam INCLUSIVE NEUTRON PRODUCTION BY PROTONS ON PROTONS AND NUCLEI.	H. Richard Gustafson	UNIVERSITY OF MICHIGAN - ANN ARBOR RUTGERS UNIVERSITY UNIVERSITY OF WISCONSIN - MADISON
	Request	22 May, 75	500 Hours
	Approval	11 Mar, 76	Parasitic Running with the condition that there will be no significant interference with other work in the Meson Laboratory
	Completed	5 Jul, 77	350 Hours
415	PARTICLE PRODUCTION #415 BEAM: Meson Area - M2 Beam MEASUREMENTS OF PI- CU TO K-SHORT, LAMBDA AND NEUTRON INCLUSIVE CROSS SECTIONS. (For proposal #360 with the apparatus of exp #8 in the M2 beam line.)	Lee G. Pondrom	BROOKHAVEN NATIONAL LABORATORY UNIVERSITY OF MICHIGAN - ANN ARBOR RUTGERS UNIVERSITY UNIVERSITY OF WISCONSIN - MADISON
	Request	24 May, 75	100 Hours
	Approval	28 Jun, 75	100 Hours
	Completed	18 Oct, 76	100 Hours
416	PARTICLE SEARCH #416 BEAM: Meson Area - M1 Beam STREAMER CHAMBER SEARCH FOR NEW STATES WHICH DECAY SEMI-LEPTONICALLY. (Using the streamer chamber originally proposed for exp #86A with additional muon counters.)	Henry J. Lubatti	UNIV. OF CALIFORNIA, DAVIS LAL, ORSAY (FRANCE) UNIVERSITY OF WASHINGTON
	Request	27 May, 75	300 Hours
	Approval	29 May, 75	300 Hours with the understanding that the total running time for exp# 416 and exp# 86A is to remain within 800 hours
	Completed	1 Jul, 75	400 Hours
418	PARTICLE PRODUCTION #418 BEAM: Internal Target Area (C-0) NUCLEAR SIZE DEPENDENCE FOR PARTICLE PRODUCTION AT INTERMEDIATE TRANSVERSE MOMENTUM. (With the spectrometer used for exp #363.)	Felix Sannes	IMPERIAL COLLEGE (ENGLAND) UNIVERSITY OF ROCHESTER RUTGERS UNIVERSITY
	Request	2 Jun, 75	Unspecified
	Approval	7 Jul, 75	500 Hours contingent upon the fact that such running does not constitute an interference with the requirements of other experiments to be run in that area
	Completed	22 Oct, 75	900 Hours
419	EMULSION/PROTONS @ 300 #419 BEAM: Neutrino Area - Miscellaneous SEARCH FOR SHORT LIVED PARTICLES PRODUCED BY 300 GEV PROTONS IN EMULSIONS.	Giorgio Giacomelli	UNIVERSITY OF BOLOGNA (ITALY)
	Request	2 Jun, 75	Emulsion Exposure
	Approval	10 Jun, 75	Emulsion Exposure
	Completed	10 Jun, 75	1 Stack(s)
421	EMULSION/PROTONS @ 300 #421 BEAM: Neutrino Area - Miscellaneous EXPOSURE OF AN EMULSION CHAMBER TO A 300 GEV/C PROTON BEAM.	Venedict P. Dzhelepov	JINR, DUBNA (RUSSIA)
	Request	18 Jun, 75	Emulsion Exposure
	Approval	18 Jun, 75	Emulsion Exposure
	Completed	24 Jun, 75	1 Stack(s)
423	EMULSION/PROTONS @ 400 #423 BEAM: Neutrino Area - Miscellaneous SEARCH FOR NEW PARTICLES IN EMULSION CHAMBERS.	Hisahiko Sugimoto	HIROSAKI UNIVERSITY (JAPAN) ICRR, UNIVERSITY OF TOKYO (JAPAN) UNIVERSITY OF TOKYO (JAPAN) WASEDA UNIVERSITY (JAPAN)
	Request	7 Jul, 75	Emulsion Exposure
	Approval	21 Jul, 75	Emulsion Exposure
	Completed	9 Dec, 75	4 Stack(s)

424	EMULSION/MUONS @ 200 #424 BEAM: Neutrino Area - Miscellaneous MULTIPLE PION PRODUCTION BY 200 GEV/C MUONS. +-----+ Request 23 Jun, 75 Emulsion Exposure Approval 9 Feb, 76 Emulsion Exposure in the muon beam while it is operating for exp# 319 at a momentum in the vicinity of 300 GeV/c Completed 8 Oct, 76 1 Stack(s)	Tomonori Wada	ASHIKAGA INST. OF TECH. (JAPAN) ICRR, UNIVERSITY OF TOKYO (JAPAN) OKAYAMA UNIVERSITY (JAPAN) SAITAMA UNIVERSITY (JAPAN)
425	K ZERO REGENERATION #425 BEAM: Meson Area - M4 Beam PROPOSAL TO INVESTIGATE REGENERATION OF NEUTRAL K-MESONS AT VERY HIGH ENERGIES. (Using a liquid hydrogen target; see exp #82.) +-----+ Request 24 Jun, 75 600 Hours Approval 18 Mar, 75 600 Hours contingent upon exp# 425 providing a hydrogen target (see exp# 82) Completed 17 May, 76 1,400 Hours	Valentine L. Telegdi	UNIV. OF CALIFORNIA, SAN DIEGO UNIVERSITY OF CHICAGO LHE, ETH HONGGERBERG (SWITZERLAND) SLAC UNIVERSITY OF WISCONSIN - MADISON
426	FRAGMENTATION PARTICLES #426 BEAM: Meson Area - Miscellaneous PROPOSAL ON THE STUDY OF FRAGMENTATION PARTICLES CREATED IN A PLASTIC DETECTOR BY 300 GEV PROTONS. +-----+ Request 27 May, 75 Detector Exposure Approval 28 Jul, 75 Detector Exposure Completed 20 Mar, 76 16 Stack(s)	Katsura Fukui	HANSCOM A.F.B. GEOPHYSICS LAB. UNIVERSITY OF KIEL (GERMANY)
427	DETECTOR DEVELOPMENT #427 BEAM: Meson Area - M1 Beam A PROPOSAL FOR TESTING A TRANSITION RADIATION DETECTOR AND A HIGH ENERGY SHOWER DETECTOR FOR COSMIC RAY EXPERIMENTS. +-----+ Request 27 Jun, 75 50 Hours Approval 4 Jan, 78 100 Hours during an opportunity for running in the M1-beam in January 1978 Completed 10 Jan, 78 40 Hours with only a portion of the objectives of the experiment finished due to problems with the M1-beam and the accelerator	Luke C. L. Yuan	BROOKHAVEN NATIONAL LABORATORY
428	EMULSION/PROTONS @ 400 #428 BEAM: Neutrino Area - Miscellaneous 400 GEV PROTON INTERACTIONS IN NUCLEAR EMULSION. +-----+ Request 4 Aug, 75 Emulsion Exposure Approval 25 Aug, 75 Emulsion Exposure Completed 9 Dec, 75 14 Stack(s)	Jacques D. Hebert	UNIVERSITY OF BELGRADE (YUGOSLAVIA) CRN, STRASBOURG (FRANCE) FERMILAB UNIVERSITY OF LUND (SWEDEN) UNIVERSITY OF LYON (FRANCE) UNIVERSITY OF NANCY (FRANCE) UNIVERSITY OF OTTAWA (CANADA) UNIV. OF PARIS VI, LPG (FRANCE) UNIVERSITY OF QUEBEC (CANADA) UNIVERSITY OF SANTANDER (SPAIN) UNIVERSITY OF VALENCIA (SPAIN) UNIV. OF WESTERN ONTARIO (CANADA)
434	EMULSION/PROTONS @ 400 #434 BEAM: Neutrino Area - Miscellaneous CASCADE SHOWERS ORIGINATED IN JET SHOWERS. +-----+ Request 16 Sep, 75 Emulsion Exposure Approval 20 Sep, 75 Emulsion Exposure Completed 9 Dec, 75 3 Stack(s)	Shoji Dake	KOBE UNIVERSITY (JAPAN) KONAN UNIVERSITY (JAPAN) SAITAMA UNIVERSITY (JAPAN) UNIVERSITY OF TOKYO (JAPAN) UTSUNOMIYA UNIVERSITY (JAPAN)
435	MUON SEARCH #435 BEAM: Proton Area - Center MEASUREMENT OF THE POLARIZATION OF PROMPT MUONS AT X = 0.14 AT P-TRANSVERSE = 0 AND P-TRANSVERSE = 1.5 GEV/C. (Extension of measurements begun in experiment #48.) +-----+ Request 18 Sep, 75 250 Hours total including 50 hours of tests Approval 25 Nov, 75 250 Hours of setup and running time Completed 2 Jul, 76 250 Hours	Robert K. Adair	BROOKHAVEN NATIONAL LABORATORY FERMILAB YALE UNIVERSITY
436	DI-MUON #436 BEAM: Proton Area - Center DETERMINATION OF THE POSSIBLE DI-MUON CHARACTER OF THE PROMPT MUON FLUX. +-----+ Request 18 Sep, 75 75 Hours including 40 hours of tests Approval 7 Oct, 75 100 Hours to be completed during the operating period due to end in Nov. 1975 Completed 29 Oct, 75 200 Hours	Robert K. Adair	BROOKHAVEN NATIONAL LABORATORY FERMILAB YALE UNIVERSITY
438	NEUTRON-NUCLEUS INELASTIC #438 BEAM: Meson Area - M3 Beam INELASTIC CROSS SECTIONS OF NEUTRONS ON NUCLEI. +-----+ Request 26 Sep, 75 500 Hours Approval 25 Nov, 75 200 Hours Completed 18 Apr, 77 350 Hours	Lawrence W. Jones	UNIVERSITY OF MICHIGAN - ANN ARBOR
439	MULTI-MUON #439 BEAM: Meson Area - M2 Beam HIGH SENSITIVITY SEARCH FOR NEW STATES WHICH DECAY INTO MUONS. +-----+ Request 26 Sep, 75 500 Hours with 200 hours for tests and 300 hours for data 31 May, 77 1,600 Hours to include 3 additional one-month periods of running Approval 25 Nov, 75 400 Hours 24 Jun, 77 800 Hours with the understanding that the 400-hour extension and time remaining under previous approval be used for investigation of multi-muon events 27 Jul, 77 800 Hours with the previous constraints on the further running removed 24 Mar, 78 1,600 Hours with an extension until the spring 1978 shutdown, but without overriding priority Completed 19 May, 78 1,700 Hours	David A. Garelick	UNIVERSITY OF MICHIGAN - ANN ARBOR NORTHEASTERN UNIVERSITY TUFTS UNIVERSITY UNIVERSITY OF WASHINGTON

440	LAMBDA MAGNETIC MOMENT #440 BEAM: Meson Area - M2 Beam PROPOSAL FOR A NEW MEASUREMENT OF THE MAGNETIC MOMENT OF THE LAMBDA HYPERON. +-----+ Request 26 Sep, 75 160 Hours Approval 25 Nov, 75 160 Hours Completed 22 Mar, 77 250 Hours	Gerry M. Bunce	UNIVERSITY OF MICHIGAN - ANN ARBOR RUTGERS UNIVERSITY UNIVERSITY OF WISCONSIN - MADISON
441	LAMBDA POLARIZATION #441 BEAM: Meson Area - M2 Beam A PROPOSAL TO STUDY LAMBDA POLARIZATION IN THE INCLUSIVE REACTION PROTON - PROTON TO LAMBDA PLUS ANYTHING WITH LIQUID HYDROGEN TARGET. (Extension of previous measurements of 300 GeV protons on beryllium to 400 GeV protons on hydrogen.) +-----+ Request 29 Sep, 75 150 Hours Approval 25 Nov, 75 150 Hours Completed 2 Jul, 77 400 Hours	Lee G. Pondrom	UNIVERSITY OF MICHIGAN - ANN ARBOR RUTGERS UNIVERSITY UNIVERSITY OF WISCONSIN - MADISON
442	NUCLEAR FRAGMENTS #442 BEAM: Internal Target Area (C-0) STUDY OF NUCLEAR FRAGMENT EMISSION IN PROTON HEAVY NUCLEUS COLLISIONS FROM 10 TO 500 GEV. (Will use room temperature gas jet target with heavy gases.) +-----+ Request 26 Sep, 75 400 Hours for data taking 11 May, 77 800 Hours to include additional time to search for quarks bound in nuclear fragments Approval 25 Nov, 75 400 Hours 25 Jun, 77 400 Hours without time for the quark search Completed 13 Aug, 77 1,200 Hours	Frank Turkot	FERMILAB PURDUE UNIVERSITY
444	DI-MUON #444 BEAM: Neutrino Area - Muon/Hadron Beam A SPECIAL REQUEST FOR HIGH-PRIORITY RUNNING TO MEASURE HIGH-MASS MUON PAIRS. (Using the Quadrupole Triplet focusing system for producing a high intensity hadron beam.) +-----+ Request 25 Sep, 75 400 Hours 31 May, 77 800 Hours with a request for a 400 hour extension for a scaling test and to increase the sensitivity at high masses Approval 24 Nov, 75 400 Hours 24 Jun, 77 400 Hours with a decision not to grant an extension Completed 3 Jan, 78 1,100 Hours	A. J. Stewart Smith	UNIVERSITY OF CHICAGO PRINCETON UNIVERSITY
448	MUON #448 BEAM: Neutrino Area - Muon/Hadron Beam PROPOSAL FOR THE INVESTIGATION OF VIRTUAL PHOTOABSORPTION BY NUCLEAR MATTER. (Using the cyclotron spectrometer and heavy targets; see proposal #257.) +-----+ Request 17 Oct, 75 300 Hours 9 Jun, 77 300 Hours to study both photoabsorption by nuclear matter and production of charmed particles (the latter to employ a Cerenkov counter) Approval 15 Mar, 77 Parasitic Running for about 300 hours concurrent with exp #203 29 Jun, 77 Parasitic Running for about 300 hours for study of photoabsorption of nuclear matter; without the disruption required to install the Cerenkov counter Completed 7 May, 78 900 Hours	William A. Loomis	UNIVERSITY OF CHICAGO FERMILAB HARVARD UNIVERSITY MASSACHUSETTS INST. OF TECHNOLOGY MICHIGAN STATE UNIVERSITY TUFTS UNIVERSITY
451	INCLUSIVE SCATTERING #451 BEAM: Meson Area - M6 Beam STUDY OF THE A-DEPENDENCE OF INCLUSIVE PROCESSES AND ASSOCIATED MULTIPLICITY. (Using the single arm spectrometer facility.) +-----+ Request 17 Oct, 75 600 Hours including 100 hours of tests Approval 30 Jun, 76 400 Hours Completed 6 Sep, 78 500 Hours	Donald S. Barton	UNIVERSITY OF BARI (ITALY) BROWN UNIVERSITY FERMILAB MASSACHUSETTS INST. OF TECHNOLOGY WARSAW HEP LABORATORY (POLAND)
456	FORM FACTOR #456 BEAM: Meson Area - M1 Beam MEASUREMENT OF THE KAON FORM FACTOR. (Continuation of work begun in exp #216.) +-----+ Request 17 Oct, 75 800 Hours including 200 hours of tests Approval 25 Nov, 75 500 Hours 7 Dec, 76 950 Hours including an additional 450 hours for data taking with a request for a report on preliminary results from existing data before the start of the next running period Completed 13 Apr, 77 1,450 Hours	Donald H. Stork	UNIV. OF CALIFORNIA, LOS ANGELES FERMILAB JINR, DUBNA (RUSSIA) NOTRE DAME UNIVERSITY UNIVERSITY OF PITTSBURGH
458	PHOTOPRODUCTION #458 BEAM: Proton Area - East PHOTOPRODUCTION EXPERIMENT AT FERMILAB. (Using the broad band photon beam; a continuation of work begun in exp #87A and #401.) +-----+ Request 17 Oct, 75 700 Hours 7 May, 76 900 Hours with 300 hours for testing, 600 hours for data Approval 2 Jul, 76 300 Hours with a total of 1,000 hours approved for the combination of expts #400, #401, and #458 14 Mar, 77 1,000 Hours with a total of 2,000 hours for the combination of expts #400, #401, #458 1 Apr, 78 Unspecified since approved running time has been used by exp #87a Approved/Inactive 27 Oct, 81 Unspecified	Wonyong Lee	COLUMBIA UNIVERSITY FERMILAB UNIVERSITY OF ILLINOIS, CHAMPAIGN
461	EMULSION/PROTONS @ 400 #461 BEAM: Neutrino Area - Miscellaneous SEARCH FOR NEW PARTICLES FROM 400 GEV PROTON COLLISIONS IN EMULSIONS. +-----+ Request 10 Nov, 75 Emulsion Exposure Approval 26 Nov, 75 6 Stack(s) Completed 9 Dec, 75 6 Stack(s)	Jere J. Lord	UNIV. OF AUCKLAND (NEW ZEALAND) AUSTRALIAN NAT'L. UNIV. (AUSTRALIA) UNIVERSITY OF MELBOURNE (AUSTRALIA) UNIVERSITY OF SYDNEY (AUSTRALIA) UNIVERSITY OF TASMANIA (AUSTRALIA) UNIVERSITY OF WASHINGTON

462	EMULSION/PROTONS @ 400 #462	Giorgio Giacomelli	UNIVERSITY OF BOLOGNA (ITALY) UNIVERSITY OF FIRENZE (ITALY)
	BEAM: Neutrino Area - Miscellaneous SEARCH FOR SHORT LIVED PARTICLES PRODUCED BY 400 GEV PROTONS IN EMULSIONS.		
	+-----+		
	Request	18 Nov, 75	Emulsion Exposure
	Approval	26 Nov, 75	Emulsion Exposure
	Completed	9 Dec, 75	1 Stack(s)
463	EMULSION/PROTONS @ 400 #463	M. I. Tretjakova	KAZAKH STATE UNIV., (KAZAKHSTAN) LEBEDEV PHYSICAL INST. (RUSSIA) ITEP, MOSCOW (RUSSIA) PNPI, ST. PETERSBURG (RUSSIA) TASHKENT, PHY.TEC.INS (UZBEKISTAN)
	BEAM: Neutrino Area - Miscellaneous THE INTERACTIONS OF PROTONS IN NUCLEAR EMULSION AT 400 GEV/C (OR 500 GEV/C).		
	+-----+		
	Request	17 Nov, 75	Emulsion Exposure
	Approval	26 Nov, 75	Emulsion Exposure
	Completed	9 Dec, 75	2 Stack(s)
466	NUCLEAR FRAGMENTS #466	Norbert T. Porile	ARGONNE NATIONAL LABORATORY UNIVERSITY OF CHICAGO UNIV. OF ILLINOIS, CHICAGO CIRCLE PURDUE UNIVERSITY
	BEAM: Proton Area - Miscellaneous A PROPOSAL FOR THE STUDY OF HIGH-ENERGY REACTION MECHANISMS BY THE MEASUREMENT OF THE ANGULAR AND ENERGY DISTRIBUTIONS OF NUCLEAR FRAGMENTS RECOILING FROM TARGETS BOMBARDED WITH 200-300 GEV PROTONS.		
	+-----+		
	Request	9 Jan, 76	500 Hours
	Approval	30 Mar, 76	500 Hours to be met on an essentially parasitic basis with the understanding that this work will not constitute an interference with the rest of the proton area program
	Completed	15 Feb, 88	102 Targets Exposed
467	TEST MUON IRRADIATION #467	Melvin Freedman	ARGONNE NATIONAL LABORATORY
	BEAM: Neutrino Area - Miscellaneous PROPOSAL FOR PARASITIC DUAL TARGET IRRADIATION WITH MUON SPILL BEAM BEHIND EXP #319.		
	+-----+		
	Request	13 Jan, 76	Target Exposure(s)
	Approval	28 Apr, 76	Parasitic Running for a bombardment of chlorine and thallium targets downstream of exp #319 or exp #398
	Completed	1 Dec, 76	4 Targets Exposed
468	PARTICLE SEARCH #468	Phillip H. Steinberg	UNIVERSITY OF MARYLAND
	BEAM: Meson Area - M2 Beam SEARCH FOR PENETRATING MASSIVE NEUTRAL PARTICLES PRODUCED IN HIGH ENERGY PROTON COLLISIONS.		
	+-----+		
	Request	21 Jan, 76	1,200 Hours
		4 Oct, 76	300 Hours in a 400 GeV proton beam at an intensity of 10 to the 9th protons/pulse
		4 Nov, 77	450 Hours including an additional 150 hours to improve the sensitivity during another run of the experiment
	Approval	18 Nov, 76	300 Hours
	Completed	14 Aug, 77	300 Hours
469	PARTICLE SEARCH #469	David Cutts	UNIVERSITY OF BARI (ITALY) BROWN UNIVERSITY CERN (SWITZERLAND) FERMILAB MASSACHUSETTS INST. OF TECHNOLOGY
	BEAM: Meson Area - M6 Beam SEARCH FOR HEAVY LONG-LIVED PARTICLES. (Using the single arm spectrometer facility.)		
	+-----+		
	Request	23 Jan, 76	150 Hours
	Approval	3 Feb, 78	150 Hours with the understanding that the schedule for this run may place the desired running for exp #451 in some jeopardy
	Completed	15 May, 78	400 Hours
472	PARTICLE SEARCH #472	Kenneth C. Stanfield	FERMILAB UNIVERSITY OF MICHIGAN - ANN ARBOR PURDUE UNIVERSITY
	BEAM: Meson Area - M2 Beam SEARCH FOR HEAVY PARTICLES PRODUCED IN ASSOCIATION WITH PROMPT MUONS. (Experiment would use modified exp #357 spectrometer.)		
	+-----+		
	Request	23 Jan, 76	600 Hours including 100 hours of tests
	Approval	10 Mar, 76	600 Hours
	Completed	29 Nov, 76	1,100 Hours
481	EMULSION/PI- @ 300 #481	Yoshiyuki Takahashi	OSAKA CITY UNIVERSITY (JAPAN) SHINSHU UNIVERSITY (JAPAN)
	BEAM: Neutrino Area - Miscellaneous INVESTIGATION OF MULTIPLE PRODUCTION BY PI - MESONS WITH EMULSION CHAMBER.		
	+-----+		
	Request	28 Apr, 76	Emulsion Exposure 10K particles per cm. sq. over a square of 10 cm x 10 cm
	Approval	12 May, 76	Emulsion Exposure
	Completed	18 Jan, 78	7 Stack(s)
482	NEUTRINO #482	Barry C. Barish	CALIFORNIA INSTITUTE OF TECHNOLOGY FERMILAB NORTHWESTERN UNIVERSITY UNIVERSITY OF ROCHESTER ROCKEFELLER UNIVERSITY
	BEAM: Neutrino Area - Quadrupole Triplet STUDY OF DI-MUON EVENTS PRODUCED IN NEUTRINO INTERACTIONS.		
	+-----+		
	Request	11 May, 76	500 Hours to be run with the Quadrupole Triplet train load with focus set at 200 GeV at 10 to the 13th protons per pulse
	Approval	30 Jun, 76	Parasitic Running with other experiments using the neutrino beam
	Completed	3 Jan, 78	1,600 Hours
486	K ZERO CROSS SECTION #486	Bruce D. Winstein	UNIVERSITY OF CHICAGO LHE, ETH HONGGERBERG (SWITZERLAND) UNIVERSITY OF WISCONSIN - MADISON
	BEAM: Meson Area - M4 Beam PROPOSAL TO STUDY THE ATOMIC NUMBER DEPENDENCE OF THE DIFFERENCE BETWEEN PARTICLE AND ANTI-PARTICLE TOTAL CROSS SECTIONS. (Using the apparatus of expts #82 and #425 with modifications.)		
	+-----+		
	Request	7 May, 76	200 Hours to be run in a modified version of the M-4 neutral beam; data taking to require 1.4 x 10 to the 17th protons into the meson production target
	Approval	30 Jun, 76	200 Hours with a total of 800 hours approved for the combination of E-486 and E-226
	Completed	17 Mar, 77	950 Hours

490	PARTICLE SEARCH #490 BEAM: Meson Area - M1 Beam SEARCH FOR SHORT LIVED PARTICLES USING A HIGH RESOLUTION STREAMER CHAMBER.	Jack Sandweiss	FERMILAB LAWRENCE BERKELEY LABORATORY YALE UNIVERSITY
	Request	7 May, 76	800 Hours to be run in a 200 GeV pi- beam of intensity 8×10 to the 5th particles per pulse focused to a 1 mm x 5 mm spot
	Approval	30 Jun, 76	Test Running to study the performance of the high resolution streamer chamber
	Completed	9 Jun, 80	850 Hours
494	DI-HADRON #494 BEAM: Proton Area - Center A STUDY OF DI-HADRON PRODUCTION IN PROTON COLLISIONS AT FERMILAB. (This experiment is an off-shoot of di-lepton #288.)	Myron L. Good	COLUMBIA UNIVERSITY FERMILAB SUNY AT STONY BROOK
	Request	10 May, 76	800 Hours
	Approval	17 May, 76	800 Hours
		17 Nov, 76	1,400 Hours including an additional six weeks of running with the experiment expected to terminate in February 1977
	Completed	21 Feb, 77	1,950 Hours
495	XI-ZERO PRODUCTION #495 BEAM: Meson Area - M2 Beam PROPOSAL TO STUDY CASCADE ZERO AND ANTILAMBDA PRODUCTION AND POLARIZATION. (Experiment would use the spectrometer of E-8.)	Kenneth J. Heller	BROOKHAVEN NATIONAL LABORATORY UNIVERSITY OF MICHIGAN - ANN ARBOR RUTGERS UNIVERSITY UNIVERSITY OF WISCONSIN - MADISON
	Request	17 May, 76	400 Hours
	Approval	17 Nov, 76	400 Hours
	Completed	28 Aug, 78	700 Hours
497	CHARGED HYPERON #497 BEAM: Proton Area - Center ELASTIC SCATTERING OF THE HYPERONS. (Measurements of charged hyperon fluxes and differential elastic cross sections, and a particle search.)	Joseph Lach	FERMILAB IOWA STATE UNIVERSITY YALE UNIVERSITY
	Request	13 May, 76	1,200 Hours with 600 hours for flux measurements and new particle search and 600 hours to measure differential cross sections
		26 Jan, 79	800 Hours including an additional 400 hours to search for the b-particle after the beam is commissioned
	Approval	29 Jun, 76	400 Hours initial approval
	Completed	16 Mar, 81	2,500 Hours see proposal #697
498	DETECTOR DEVELOPMENT #498 BEAM: Proton Area - East A MEASUREMENT OF THE RELATIVISTIC RISE IN THE MOST PROBABLE ENERGY LOSS IN THIN SOLID FILMS.	Charles R. Gruhn	LOS ALAMOS NATIONAL LABORATORY
	Request	26 May, 76	50 Hours in an electron beam at the highest energies available
	Approval	14 Jun, 76	Parasitic Running that will not disturb the normal proton area program
	Completed	16 Aug, 76	50 Hours
499	EMULSION/PROTONS @ 400 #499 BEAM: Neutrino Area - Miscellaneous A STUDY OF ANGULAR DISTRIBUTIONS IN PROTON-NUCLEUS COLLISIONS USING NUCLEAR EMULSIONS.	Junsuke Iwai	WASEDA UNIVERSITY (JAPAN)
	Request	1 Jun, 76	2 Exposure(s)
	Approval	16 Aug, 76	Emulsion Exposure with one stack exposed to an intensity of 600K protons/sq cm and a second to an intensity of 10K protons/sq cm
	Completed	15 Jan, 78	5 Stack(s)
501	TEST MUON IRRADIATION #501 BEAM: Neutrino Area - Muon/Hadron Beam PROPOSAL FOR A MEASUREMENT OF THE TRANSITION RATE FOR CL(37) AND AR(37) INDUCED BY MUONS AT FERMILAB ENERGIES.	Kenneth Lande	BROOKHAVEN NATIONAL LABORATORY UNIVERSITY OF PENNSYLVANIA
	Request	11 Aug, 76	25 Hours an integrated flux of - about 5×10 to the 9th times (e/300) to the 0.7th - muons @ 75, 150, and 250 GeV
	Approval	28 Oct, 76	Target Exposure(s) parasitic to running of upstream muon experiments
	Completed	1 Dec, 76	2 Targets Exposed
502	MONOPOLE #502 BEAM: Neutrino Area - Miscellaneous SEARCH FOR MONOPOLES ABOVE THE 15-FOOT BUBBLE CHAMBER. (Would require a scuttle in the roof of the 15-foot bubble chamber building.)	David F. Bartlett	UNIVERSITY OF COLORADO AT BOULDER GENERAL ELECTRIC R&D CENTER
	Request	30 Jul, 76	Cosmic Ray Running to include use of the fringe field of the 15-foot bubble chamber magnet during two long runs; approximately 7 months of data-taking requested with lexan and later with emulsion detectors
	Approval	2 Sep, 76	Cosmic Ray Running during parasitic operation in the fringe field of the 15-foot bubble chamber magnet
	Completed	23 Jun, 80	Cosmic Ray Running
503	EMULSION/PI- @ 300 #503 BEAM: Neutrino Area - Miscellaneous MULTIPARTICLE PRODUCTION IN HIGH ENERGY PION-NUCLEUS INTERACTIONS.	Takeshi Ogata	HIROSAKI UNIVERSITY (JAPAN) ICRR, UNIVERSITY OF TOKYO (JAPAN) KONAN UNIVERSITY (JAPAN) KWANSEI GAKUIN UNIVERSITY (JAPAN)
	Request	12 Aug, 76	Emulsion Exposure consisting of eight blocks of mulsion exposed to 50K particles/sq cm in a pi- beam of 200 GeV/c or greater
	Approval	19 Aug, 76	Emulsion Exposure
	Completed	18 Jan, 78	4 Stack(s)

505	PROTON POLARIZATION #505 BEAM: Meson Area - M2 Beam A SEARCH FOR PROTON POLARIZATION IN INCLUSIVE PRODUCTION AT 300 GEV/C.	Samuel Peter Yamin	BROOKHAVEN NATIONAL LABORATORY UNIVERSITY OF MICHIGAN - ANN ARBOR RUTGERS UNIVERSITY UNIVERSITY OF WISCONSIN - MADISON
	Request	16 Aug, 76	100 Hours with a change in the targetting angle of the primary proton beam for the meson area
	Approval	29 Jun, 78	100 Hours with low priority during the time available for exp #495
	Completed	27 Aug, 78	50 Hours
506	EMULSION/PI- @ 300 #506 BEAM: Neutrino Area - Miscellaneous CASCADE SHOWERS ORIGINATED IN JET SHOWERS DUE TO NEGATIVE PIONS.	Shoji Dake	KOBE UNIVERSITY (JAPAN) KONAN UNIVERSITY (JAPAN) SAITAMA UNIVERSITY (JAPAN) UNIVERSITY OF TOKYO (JAPAN)
	Request	17 Aug, 76	Emulsion Exposure using two - three emulsion chambers 10 cm x 10 cm x 8 xm exposed to 10-100 particles/sq cm in a pi- beam of 200 GeV/c or greater
	Approval	23 Aug, 76	Emulsion Exposure
	Completed	15 Jan, 78	2 Stack(s)
507	HIGH ENERGY CHANNELING #507 BEAM: Meson Area - M1 Beam PROPOSAL TO STUDY CHANNELING AT FERMILAB. (Using the spectrometer of exp #456.)	Edward N. Tsyganov	UNIV. OF CALIFORNIA, LOS ANGELES FERMILAB JINR, DUBNA (RUSSIA) KHARKOV PHYS-TECH INST (UKRAINE) LEHIGH UNIVERSITY ITEP, MOSCOW (RUSSIA) SUNY AT ALBANY TOMSK POLYTECH. INST. (USSR) INR, WARSAW (POLAND)
	Request	8 Sep, 76	250 Hours use of the M-1 beam is requested in conjunction with operation of form factor #456
	Approval	1 Jun, 77	250 Hours with the understanding that this activity will not delay significantly the program in the M1 beam
	Completed	30 May, 77	350 Hours
508	EMULSION/PROTONS @ 500 #508 BEAM: Meson Area - Test Beam STUDY OF THE MECHANISM FOR MULTIPLE PRODUCTION OF PARTICLES AT HIGH ENERGIES.	Wladyslaw Wolter	INP, KRAKOW (POLAND)
	Request	15 Sep, 76	Emulsion Exposure consisting of 3 emulsion stacks
	Approval	24 Sep, 76	Emulsion Exposure
	Completed	26 Apr, 85	7 Emulsion Stack(s)
509	EMULSION/MUONS @ 200 #509 BEAM: Neutrino Area - Miscellaneous SEARCH FOR THE LARGE ANGLE SCATTERING OF MUONS.	T. Shirai	KANAGAWA UNIVERSITY (JAPAN) KOBE UNIVERSITY (JAPAN) UNIVERSITY OF TOKYO (JAPAN)
	Request	13 Sep, 76	Emulsion Exposure of 10 to the 6th particles/sq cm
	Approval	24 Sep, 76	Emulsion Exposure
	Completed	8 Oct, 76	1 Stack(s)
510	EMULSION/ELECTRONS @ HI E #510 BEAM: Proton Area - Miscellaneous STUDY OF CASCADE SHOWERS INITIATED BY ELECTRONS.	Kiyoshi Niu	AICHI UNIV. OF EDUCATION (JAPAN) NAGOYA UNIVERSITY (JAPAN) YOKOHAMA NATIONAL UNIV. (JAPAN)
	Request	9 Sep, 76	Emulsion Exposure
	Approval	24 Sep, 76	Emulsion Exposure
	Completed	5 Oct, 76	6 Stack(s)
515	PARTICLE SEARCH #515 BEAM: Meson Area - M1 Beam PROPOSAL TO STUDY CHARGED PARTICLES PRODUCED IN HADRONIC INTERACTIONS.	Jerome L. Rosen	CARNEGIE-MELLON UNIVERSITY FERMILAB NORTHWESTERN UNIVERSITY NOTRE DAME UNIVERSITY
	Request	5 Oct, 76	1,000 Hours in a high intensity pi- beam @ 200 GeV/c
	Approval	14 Mar, 77	800 Hours
	Completed	10 Mar, 82	2,650 Hours
516	PHOTOPRODUCTION #516 BEAM: Proton Area - East A STUDY OF PHOTOPRODUCTION USING A MAGNETIC SPECTROMETER AT THE TAGGED PHOTON LAB.	E. Thomas Nash	UNIV. OF CALIFORNIA, SANTA BARBARA CARELTON UNIVERSITY (CANADA) UNIVERSITY OF COLORADO AT BOULDER FERMILAB NATIONAL RESEARCH COUNCIL (CANADA) UNIVERSITY OF OKLAHOMA UNIVERSITY OF TORONTO (CANADA)
	Request	5 Oct, 76	1,000 Hours in the tagged photon beam assuming a primary beam of 450 GeV protons with 2.9 x 10 to the 15th protons/hour
		3 Oct, 77	1,000 Hours with 6 x 10 to the 12th protons per pulse, a 1 sec. flattop and a 10 sec. cycle
	Approval	15 Nov, 77	1,000 Hours to include 400 hours for testing and 600 hours for data
	Completed	1 Jun, 81	4,500 Hours
522	PROTON POLARIZATION #522 BEAM: Internal Target Area (C-0) A STUDY OF INCLUSIVE PROTON POLARIZATION.	Harold O. Ogren	INDIANA UNIVERSITY
	Request	28 Oct, 76	840 Hours the experiment would run with the existing exp #313 set-up in the internal target area
	Approval	25 Jun, 77	800 Hours conditional on cryogenic operation of the internal target area
	Completed	21 Mar, 78	700 Hours
524	EMULSION/PROTONS > 500 GEV #524 BEAM: Meson Area - Test Beam PROPOSAL TO STUDY INTERACTIONS OF PROTONS OF ENERGY GREATER THAN 500 GEV IN EMULSION AND HEAVY NUCLEI.	Richard J. Wilkes	UNIVERSITY OF WASHINGTON
	Request	18 Jan, 77	Emulsion Exposure of 10 plates would be exposed to fluxes ranging from 75,000 to 200,000 particles/sq.cm.
	Approval	3 Mar, 77	Emulsion Exposure with a momentum of approximately 500 GeV/c
	Completed	26 Apr, 85	6 Emulsion Stack(s)

525	EMULSION/PI- @ 300 #525 BEAM: Neutrino Area - Miscellaneous PROPOSAL TO STUDY PROTON-NUCLEUS INTERACTIONS IN EMULSION PLATES WITH EMBEDDED METAL POWDER GRANULES AT 300 GEV.	Richard J. Wilkes	UNIVERSITY OF WASHINGTON
	Request	18 Jan, 77	Emulsion Exposure of 10 plates would be exposed in a negative beam to fluxes ranging from 75,000 - 200,000 particles/sq.cm.
	Approval	13 Dec, 77	Emulsion Exposure with a request for the beam energy to be changed to 300 GeV
	Completed	3 Mar, 77 15 Jan, 78	Emulsion Exposure 2 Stack(s)
531	NEUTRINO #531 BEAM: Neutrino Area - Wide Band Horn A PROPOSAL TO STUDY WEAK DECAY LIFETIMES OF NEUTRINO PRODUCED PARTICLES IN A TAGGED EMULSION SPECTROMETER.	Neville W. Reay	AICHI UNIV. OF EDUCATION (JAPAN) FERMILAB ICRR, UNIVERSITY OF TOKYO (JAPAN) KOBE UNIVERSITY (JAPAN) KOREA UNIVERSITY, SEOUL (KOREA) MCGILL UNIVERSITY (CANADA) NAGOYA UNIVERSITY (JAPAN) OHIO STATE UNIVERSITY OKAYAMA UNIVERSITY (JAPAN) OSAKA CITY UNIVERSITY (JAPAN) OSAKA SCIENCE EDUC. INST. (JAPAN) UNIVERSITY OF OTTAWA (CANADA) UNIVERSITY OF TORONTO (CANADA) VIRGINIA TECH YOKOHAMA NATIONAL UNIV. (JAPAN)
	Request	31 Jan, 77 19 May, 78 8 May, 79	1,500 Hours or a total proton flux of 3×10 to the 18th 3,000 Hours including a second parasitic run 2,250 Hours total with an additional 1,100 hours requested for two runs of 6×10 to the 18th protons each, the first to be neutrinos (350 GeV pi+), the second to be antineutrinos (350 GeV pi- with the plug out)
	Approval	15 Mar, 77 1 Jul, 79	Parasitic Running concurrent with other neutrino experiments Parasitic Running concurrent with the next 15-foot bubble chamber neutrino run with the Wide Band Horn
	Completed	1 Jun, 81	3,800 Hours
533	PI-MU ATOMS #533 BEAM: Meson Area - M3 Beam PROPOSAL TO MEASURE THE RATE OF FORMATION OF PI-MU ATOMS IN K-LONG M 3 DECAY.	Gordon B. Thomson	UNIVERSITY OF CHICAGO STANFORD UNIVERSITY UNIVERSITY OF WISCONSIN - MADISON
	Request	1 Feb, 77	500 Hours based on 3×10 to the 6th K-longs/pulse in the M3 beam
	Approval	18 Mar, 77 19 Mar, 79	500 Hours with the requirement that preliminary studies and tests show that costs for the experiment are reasonable 2,100 Hours for the additional 1,500 hours requested for tuneup and data to complete the experiment
	Completed	28 Nov, 79	2,050 Hours
536	EMULSION/NEUTRINO #536 BEAM: Neutrino Area - Wide Band Horn STUDY OF NEUTRINO INTERACTIONS IN NUCLEAR EMULSIONS.	Kiyoshi Niu	AICHI UNIV. OF EDUCATION (JAPAN) NAGOYA UNIVERSITY (JAPAN) YOKOHAMA NATIONAL UNIV. (JAPAN)
	Request	2 Feb, 77	500 Hours or 1×10 to the 18th protons to be run in the broad band neutrino beam on a parasitic basis with the regular neutrino program
	Approval	10 Feb, 77	Parasitic Running
	Completed	13 Aug, 77	2 Stack(s)
537	DI-MUON #537 BEAM: Proton Area - West PROPOSAL TO STUDY PBAR-N INTERACTIONS IN THE P-WEST HIGH INTENSITY LABORATORY	Bradley B. Cox	UNIVERSITY OF ATHENS (GREECE) FERMILAB MCGILL UNIVERSITY (CANADA) UNIVERSITY OF MICHIGAN - ANN ARBOR SHANDONG UNIVERSITY (PRC)
	Request	14 Feb, 77	1,700 Hours with 300 hours of tuning and 600 hours initial data run to be followed by 800 hours for final data run, all in high intensity secondary beam
		31 Oct, 77	1,400 Hours to include 100 hours of tuneup, 300 hours of pi- @ 200 or 300 GeV, 700 hours of pi+ @ 200 or 300 GeV and 300 hours of pbar @ 100 GeV in high intensity secondary beam. Phase 1 would consist of 250 hours for tune up and 750 hours for data taking on di-muon production by p bars. Phase 2 would consist of 250 hours for tune up and 750 hours for data taking on di-electron production by p bars
		31 Jan, 78	2,000 Hours
	Approval	16 Mar, 78	1,000 Hours for study of di-muon production by pbars
	Completed	28 Feb, 82	2,700 Hours
540	PARTICLE SEARCH #540 BEAM: Meson Area - M3 Beam A SEARCH FOR NEW METASTABLE PARTICLES TRAPPED IN MATTER.	Michael J. Longo	UNIVERSITY OF MICHIGAN - ANN ARBOR
	Request	22 Mar, 77	1,900 Hours with a running period of six months in the M3 beam. The beam would be used 50 - 75% of the time available.
	Approval	23 May, 77	Parasitic Running conditional on negotiation of an agreement and that the experiment will be mounted and run under low priority conditions
	Completed	21 Feb, 78	600 Hours
545	15-FOOT NEUTRINO/D2&H12 #545 BEAM: Neutrino Area - Wide Band Horn PROPOSAL FOR AN EXTENSION OF E-151/E-227 TO STUDY NEUTRINO INTERACTIONS IN DEUTERIUM IN THE 15-FOOT BUBBLE CHAMBER WITH PLATES. (An initial run will be without plates.)	George A. Snow	ILLINOIS INSTITUTE OF TECHNOLOGY UNIVERSITY OF MARYLAND SUNY AT STONY BROOK TOHOKU UNIVERSITY (JAPAN) TUFTS UNIVERSITY
	Request	18 Apr, 77 21 Dec, 77	300 K Pix 500 K Pix to be run in the wide band beam with 1.3×10 to the 13th protons per pulse incident on the target at 400 GeV
	Approval	16 Mar, 78	350 K Pix or equivalently 3.5×10 to the 18th protons; with the assumption that the test of the plate system will be successful
		28 Jun, 78	350 K Pix to be run in the 15-ft chamber without plates
	Completed	17 Jan, 79	317 K Pix

546	15-FOOT NEUTRINO/H2&NE #546 BEAM: Neutrino Area - Quadrupole Triplet HIGH ENERGY NEUTRINO AND ANTINEUTRINO INTERACTIONS IN THE 15-FOOT BUBBLE CHAMBER USING THE QUADRUPOLE TRIPLET TRAIN LOAD AND THE TWO-PLANE EMI.	Fred Russell Huson	UNIV. OF CALIFORNIA, BERKELEY FERMILAB UNIVERSITY OF HAWAII AT MANOA LAWRENCE BERKELEY LABORATORY UNIVERSITY OF WASHINGTON UNIVERSITY OF WISCONSIN - MADISON
	+-----+		
	Request	27 Apr, 77	250 K Pix with specific interest in an exposure of 5×10 to the 18th protons
	Approval	29 Jun, 77	Parasitic Running concurrent with other neutrino running with the Quad Triplet train
	Completed	26 Jan, 78	375 K Pix
547	EMULSION/PROTONS @ 400 #547 BEAM: Neutrino Area - Miscellaneous ANGULAR CORRELATIONS STUDY IN PROTON-NUCLEI JETS AT 400-500 GEV USING EMULSION TELESCOPE TECHNIQUES.	C. J. Jacquot	CRN, STRASBOURG (FRANCE) UNIVERSITY OF LYON (FRANCE) UNIVERSITY OF SANTANDER (SPAIN)
	+-----+		
	Request	27 Apr, 77	Emulsion Exposure in a 400-500 GeV proton beam with incoming flux of 5×10 to the 4th particles over a surface 5×5 cm sq.
	Approval	14 Jun, 77	Emulsion Exposure
	Completed	15 Jan, 78	24 Stack(s)
549	QUARK #549 BEAM: Neutrino Area - Miscellaneous A SEARCH FOR FRACTIONAL CHARGES USING ACCELERATOR AND LOW TEMPERATURE TECHNIQUES.	Michael J. Longo	UNIVERSITY OF MICHIGAN - ANN ARBOR STANFORD UNIVERSITY
	+-----+		
	Request	2 May, 77	Parasitic Running to expose at least 12 niobium spheres in the vicinity of a proton beam with intensities of $> 1 \times 10$ to the 13th per pulse
	Approval	16 May, 77	Parasitic Running contingent on the target being prepared and provided by the experimenters
	Approved/Inactive	1 Oct, 78	1 Target Exposure(s) as of 1 Oct 1978
552	P-N SCATTERING #552 BEAM: Internal Target Area (C-0) A PROPOSAL TO STUDY P - P ELASTIC AND P - D COHERENT SCATTERING.	Felix Sannes	IMPERIAL COLLEGE (ENGLAND) UNIVERSITY OF ROCHESTER RUTGERS UNIVERSITY
	+-----+		
	Request	6 May, 77	900 Hours
	Approval	25 Jun, 77	800 Hours conditional on cryogenic operation of the Internal Target Area
	Completed	9 Apr, 78	950 Hours
553	NEUTRINO #553 BEAM: Neutrino Area - Wide Band Horn A PROPOSAL TO SEARCH FOR SHORT-LIVED PARTICLES PRODUCED BY ANTINEUTRINOS AND NEUTRINOS (Using a hybrid emulsion-visual detector.)	Paul F. Shepard	CORNELL UNIVERSITY UNIVERSITY OF LIBRE (BELGIUM) UNIVERSITY OF LUND (SWEDEN) UNIVERSITY OF OKLAHOMA UNIVERSITY OF PADOVA (ITALY) UNIVERSITY OF PITTSBURGH INFN, ROME (ITALY) UNIVERSITY OF SYDNEY (AUSTRALIA) UNIVERSITY OF TORINO (ITALY) YORK UNIVERSITY (CANADA)
	+-----+		
	Request	6 May, 77	2,000 Hours with a specific request for 4×10 to the 18th protons
		5 Mar, 79	2,500 Hours total with an additional 1,000 hours for a run of at least 7×10 to the 18th protons with the broad band beam tuned for neutrinos
	Approval	24 Jun, 77	Parasitic Running conditional on review of detector tests
		16 Nov, 77	Parasitic Running conditional on review of detector tests in January 1978
		1 Jul, 79	Parasitic Running concurrent with the next 15-foot bubble chamber neutrino run with the Wide Band Horn
	Completed	1 Apr, 80	1,500 Hours
555	NEUTRAL HYPERON #555 BEAM: Meson Area - M2 Beam A PROPOSAL TO STUDY CROSS SECTIONS AND POLARIZATION IN NEUTRAL STRANGE PARTICLE PRODUCTION AT HIGH TRANSVERSE MOMENTUM. (Using the neutral hyperon beam and associated experimental apparatus.)	Thomas J. Devlin	UNIVERSITY OF MICHIGAN - ANN ARBOR UNIVERSITY OF MINNESOTA RUTGERS UNIVERSITY UNIVERSITY OF WISCONSIN - MADISON
	+-----+		
	Request	6 May, 77	250 Hours for tuneup and data
		19 May, 78	530 Hours for tuning and data at intensities of 1×10 to the 11th per pulse
	Approval	15 Nov, 78	450 Hours
	Completed	17 Feb, 82	650 Hours
557	HADRON JETS #557 BEAM: Meson Area - Test Beam PROPOSAL TO STUDY HADRON JETS WITH THE CALORIMETER TRIGGERED MULTIPARTICLE SPECTROMETER. (Continuation of work begun in exp #260.)	Ernest I. Malamud	UNIVERSITY OF ARIZONA CALIFORNIA INSTITUTE OF TECHNOLOGY FERMILAB FLORIDA STATE UNIVERSITY GEORGE MASON UNIVERSITY UNIV. OF ILLINOIS, CHICAGO CIRCLE INDIANA UNIVERSITY UNIVERSITY OF MARYLAND IHEP, PROTIVNO (SERPUKHOV) (RUSSIA) RUTGERS UNIVERSITY
	+-----+		
	Request	9 May, 77	1,600 Hours for data with a suggested run plan as follows - 400 hours at 200 GeV, 800 hours with upgraded M6-beam at 300 GeV, and 400 hours at 400 GeV
	Approval	24 Jun, 77	1,600 Hours conditional on a better understanding of beam requirements for the experiment after an upgrading of the M6 beam
	Completed	14 Jul, 84	1,470 Hours

564	15-FOOT & EMULSION/NEUTRINO#564 BEAM: Neutrino Area - Wide Band Horn DIRECT DETECTION OF SHORT-LIVED PARTICLES FROM NEUTRINO INTERACTIONS IN NUCLEAR EMULSIONS INSIDE THE 15-FOOT BUBBLE CHAMBER.	Louis Voyvodic	FERMILAB ILLINOIS INSTITUTE OF TECHNOLOGY JINR, DUBNA (RUSSIA) UNIVERSITY OF KANSAS INP, KRAKOW (POLAND) ITEP, MOSCOW (RUSSIA) IHEP, PROTIVNO (SERPUKHOV) (RUSSIA) INST. FOR NUCL. RESEARCH (BULGARIA) UNIVERSITY OF SYDNEY (AUSTRALIA) UNIVERSITY OF WASHINGTON
	Request	11 May, 77	1,500 Hours with a specific request for neutrinos from a total proton flux of 3 x 10 to the 18th; running is proposed during the 15-foot running period with a deuterium fill planned for the spring of 1978
		8 May, 79	1,100 Hours additional to be run parasitically in the 15-ft chamber. film from two auxiliary cameras is requested for the neutrino portion of the running
	Approval	24 Jun, 77	Parasitic Running with the understanding that the experiment impose only a small impact on the 15-ft chamber operations
		1 Jul, 79	Parasitic Running with the understanding that the experiment impose only a small impact on the 15-ft chamber operations
	Completed	9 Mar, 81	277 K Pix
565	30-INCH HYBRID #565 BEAM: Neutrino Area - 30 in. Hadron Beam A STUDY OF THE DETAILED CHARACTERISTICS OF HADRON-NUCLEUS COLLISIONS USING THE FERMILAB HYBRID SPECTROMETER. (The experiment would be run with aluminum, silver, and gold foil targets mounted inside the 30-inch hydrogen-filled bubble chamber.)	Irwin A. Pless	BROWN UNIVERSITY FERMILAB COLLEGE DE FRANCE (FRANCE) INDIANA UNIVERSITY MASSACHUSETTS INST. OF TECHNOLOGY NIJMEGEN UNIVERSITY (NETHERLANDS) OAK RIDGE NATIONAL LABORATORY RUTGERS UNIVERSITY STEVENS INSTITUTE OF TECHNOLOGY UNIVERSITY OF TEL-AVIV (ISRAEL) UNIVERSITY OF TENNESSEE, KNOXVILLE TOHOKU GAKUIN UNIVERSITY (JAPAN) TOHOKU UNIVERSITY (JAPAN) YALE UNIVERSITY
	Request	2 Jun, 77	3,000 K Pix in a 400 GeV proton beam (400 hours, 1,000K pix) and a 200 GeV proton plus pion beam (800 hours, 2,000K pix)
		7 Feb, 78	2,000 K Pix to be taken as follows- 500K pix with 200 GeV incident protons 500K pix with 200 GeV incident pi+ 800K pix with 200 GeV incident pi- 200K pix with 400 GeV incident protons
	Approval	16 Mar, 78	Parasitic Running with exp #570
	Completed	1 Jun, 82	1,068 K Pix total for E-565 and E-570
567	PARTICLE SEARCH #567 BEAM: Proton Area - West SEARCH FOR CHARM PRODUCTION IN 200 GEV/C HADRON INTERACTIONS. (Using the spectrometer for exp #302 with additions.)	Michael S. Witherell	BROOKHAVEN NATIONAL LABORATORY CEN-SACLAY (FRANCE) FERMILAB PRINCETON UNIVERSITY UNIVERSITY OF TORINO (ITALY)
	Request	13 Jun, 77	500 Hours
	Approval	24 Jun, 77	500 Hours with 100 hours for checkout and 400 hours for data-taking
	Completed	7 Nov, 79	1,650 Hours see exp #650
568	EMULSION/PI- @ 300 #568 BEAM: Neutrino Area - Miscellaneous 300 GEV PION INTERACTIONS IN NUCLEAR EMULSION.	Jacques D. Hebert	UNIVERSITY OF BELGRADE (YUGOSLAVIA) CRN, STRASBOURG (FRANCE) FERMILAB UNIVERSITY OF LUND (SWEDEN) UNIVERSITY OF NANCY (FRANCE) UNIVERSITY OF OTTAWA (CANADA) UNIV. OF PARIS VI, LPG (FRANCE) LRC, LYON (FRANCE) UNIVERSITY OF SANTANDER (SPAIN) UNIVERSITY OF VALENCIA (SPAIN)
	Request	8 Aug, 77	Emulsion Exposure of 3 stacks in a negative beam of about 30K particles per cm sq.
	Approval	16 Sep, 77	Emulsion Exposure of 3 stacks in a 300 GeV negative beam with a flux of 30K particles per cm sq over an area of 3 x 3 cm sq
	Completed	15 Jan, 78	3 Stack(s)
570	30-INCH HYBRID #570 BEAM: Neutrino Area - 30 in. Hadron Beam PROPOSAL FOR A STUDY OF PARTICLE PRODUCTION AND DYNAMICS FROM X = 0 TO X = 1 AND THE DEPENDENCE ON INCIDENT QUANTUM NUMBERS. (Supercedes proposal #488. Will use the forward gamma detector and the downstream ISIS system with the 30-inch hybrid spectrometer.)	Irwin A. Pless	BROWN UNIVERSITY FERMILAB COLLEGE DE FRANCE (FRANCE) INDIANA UNIVERSITY MASSACHUSETTS INST. OF TECHNOLOGY NIJMEGEN UNIVERSITY (NETHERLANDS) OAK RIDGE NATIONAL LABORATORY RUTGERS UNIVERSITY STEVENS INSTITUTE OF TECHNOLOGY UNIVERSITY OF TEL-AVIV (ISRAEL) UNIVERSITY OF TENNESSEE, KNOXVILLE TOHOKU GAKUIN UNIVERSITY (JAPAN) TOHOKU UNIVERSITY (JAPAN) YALE UNIVERSITY
	Request	16 Sep, 77	2,000 K Pix to be taken with the 30-inch hybrid spectrometer exposed to two beams, 1,000K pix in a positive beam with 10% K+ and equal fractions of protons and pi+, and 1,000K pix in a negative beam with 20% pbars
	Approval	16 Mar, 78	1,500 Hours for a run of 15 weeks duration; combined with exp #565
	Completed	1 Jun, 82	1,068 K Pix total for E-565 and E-570
573	EMULSION/PI- @ 300 #573 BEAM: Neutrino Area - Miscellaneous A SEARCH FOR CHARMED PARTICLES PRODUCED BY 300 GEV/C NEGATIVE PIONS IN NUCLEAR EMULSION.	Noriyuki Ushida	AICHI UNIV. OF EDUCATION (JAPAN) NAGOYA UNIVERSITY (JAPAN) YOKOHAMA NATIONAL UNIV. (JAPAN)
	Request	29 Nov, 77	3 Stack(s) exposed in a negative pion beam to an integrated flux of 7.5 x 10 to the 3rd particles per cm sq
	Approval	29 Nov, 77	3 Stack(s)
	Completed	15 Jan, 78	3 Stack(s)

574	EMULSION/PI- @ 300 #574 BEAM: Neutrino Area - Miscellaneous A STUDY OF THE MECHANISM FOR MULTIPLE PRODUCTION OF PARTICLES AT OR ABOVE 300 GEV PION INTERACTIONS IN NUCLEAR EMULSION.	Wladyslaw Wolter	INP, KRAKOW (POLAND)
	Request	1 Dec, 77	3 Stack(s) exposed in a 300 GeV negative pion beam to an integrated intensity of 5 x 10 to the 4th particles per cm sq
	Approval	1 Dec, 77	3 Stack(s)
	Completed	18 Jan, 78	4 Stack(s)
575	EMULSION/PROTONS @ 400 #575 BEAM: Neutrino Area - Miscellaneous PROPOSAL TO STUDY 400 GEV PROTON INTERACTIONS IN NUCLEAR EMULSION.	Jere J. Lord	UNIVERSITY OF WASHINGTON
	Request	13 Dec, 77	2 Stack(s) to be exposed in a 400 GeV proton beam focused to a diameter of less than 5-10 mm. One stack to receive a total dose of 100K p/cm sq and the other 200K p/cm sq.
	Approval	13 Dec, 77	2 Stack(s)
	Completed	15 Jan, 78	2 Stack(s)
576	EMULSION/PROTONS @ 500 #576 BEAM: Neutrino Area - Miscellaneous 500 GEV PROTON INTERACTIONS IN NUCLEAR EMULSION	Jacques D. Hebert	UNIVERSITY OF BELGRADE (YUGOSLAVIA) CRN, STRASBOURG (FRANCE) FERMILAB UNIVERSITY OF LUND (SWEDEN) UNIVERSITY OF LYON (FRANCE) UNIVERSITY OF NANCY (FRANCE) UNIVERSITY OF OTTAWA (CANADA) UNIV. OF PARIS VI, LPG (FRANCE) UNIVERSITY OF SANTANDER (SPAIN) UNIVERSITY OF VALENCIA (SPAIN)
	Request	21 Dec, 77	Emulsion Exposure exposed in a 500 GeV proton beam to a total integrated flux of 3 x 10 to the 4th particles per cm sq
	Approval	20 Feb, 78	Emulsion Exposure
	Completed	11 Jul, 85	1 Emulsion Stack(s)
577	ELASTIC SCATTERING #577 BEAM: Meson Area - M6 Beam PROPOSAL TO MEASURE PI P ELASTIC SCATTERING AT LARGE ANGLES.	Roy Rubinstein	UNIVERSITY OF ARIZONA UNIV. OF CALIFORNIA, SAN DIEGO CORNELL UNIVERSITY FERMILAB
	Request	30 Jan, 78	1,000 Hours to be run in a 200 GeV incident beam with a beam flux between 5 x 10 to the 7th and 5 x 10 to the 8th pions per pulse
	Approval	29 Jun, 78	1,000 Hours
	Completed	16 Mar, 81	1,550 Hours
580	PARTICLE SEARCH #580 BEAM: Meson Area - M6 Beam A SEARCH FOR NARROW AND BROAD RESONANCES DECAYING INTO LAMBDA-LAMBDA BAR, LAMBDA-LAMBDA BAR-PI, K SHORT AND K SHORT-K SHORT-PI FROM PI- P INTERACTIONS AT 300 GEV USING THE FERMILAB MPS.	Daniel R. Green	UNIVERSITY OF ARIZONA FERMILAB FLORIDA STATE UNIVERSITY NOTRE DAME UNIVERSITY TUFTS UNIVERSITY VANDERBILT UNIVERSITY VIRGINIA TECH
	Request	31 Jan, 78	800 Hours to be run in a pion beam with an incident flux of 1.5 x 10 to the 6th pions per pulse at 300 GeV
	Approval	29 Jun, 78	800 Hours
	Completed	1 Jun, 81	800 Hours
581	POLARIZED SCATTERING #581 BEAM: Meson Area - Polarized Proton Beam CONSTRUCTION OF A POLARIZED BEAM FACILITY IN THE MESON LABORATORY AND EXPERIMENTS USING SUCH A FACILITY. (Using the M2-beam converted to a polarized proton/antiproton beam.)	Akihiko Yokosawa	ARGONNE NATIONAL LABORATORY CEN-SACLAY (FRANCE) FERMILAB HIROSHIMA UNIVERSITY (JAPAN) UNIVERSITY OF IOWA KYOTO SANGYO UNIVERSITY (JAPAN) KYOTO UNIVERSITY (JAPAN) KYOTO UNIV. OF EDUCATION (JAPAN) LAPP, D'ANNEY-LE-VIEUX (FRANCE) LOS ALAMOS NATIONAL LABORATORY NORTHWESTERN UNIVERSITY UN. OF OCCUP. & ENV. HEALTH (JAPAN) IHEP, PROTIVNO (SERPUKHOV) (RUSSIA) RICE UNIVERSITY UNIVERSITY DI TRIESTE (ITALY) UNIVERSITY OF UDINE (ITALY)
	Request	31 Jan, 78	1,200 Hours to include- 600 hours for total cross section difference measurements 600 hours for asymmetry measurements in inclusive pion production
		30 Jan, 79	1,670 Hours to include- 200 hours for beam measurements 1,000 hours for high p-transverse physics 220 hours for cross section measurements 250 hours for hadron production at large-x
	Approval	27 Nov, 79	Unspecified approval for the construction of a polarized beam only There is no approval yet for any experiment to use the beam.
	Approved/Inactive	10 Feb, 84	Unspecified
584	PARTICLE SEARCH #584 BEAM: Meson Area - M3 Beam PROPOSAL TO SEARCH FOR THE DECAY OF NEW LONG-LIVED NEUTRAL PARTICLES WITH A MASS AND LIFETIME EXCEEDING THAT OF THE K LONG.	Bruce D. Winstein	UNIVERSITY OF CHICAGO STANFORD UNIVERSITY UNIVERSITY OF WISCONSIN - MADISON
	Request	31 Jan, 78	300 Hours to be run in the M3 beam as modified for experiment #533
	Approval	29 Jun, 78	300 Hours with low priority
	Completed	22 Jan, 80	400 Hours

585	KAON CHARGE EXCHANGE #585 BEAM: Meson Area - M4 Beam A PROPOSAL TO STUDY EXCLUSIVE KN CHARGE EXCHANGE AT FERMILAB. (The spectrometer from experiment #383 would be used.)	William R. Francis	UNIV. OF CALIFORNIA, DAVIS UNIV. OF CALIFORNIA, SAN DIEGO CARELTON UNIVERSITY (CANADA) MICHIGAN STATE UNIVERSITY
	Request	31 Jan, 78 600 Hours to be run immediately following the conclusion of exp #383 13 Nov, 78 2,700 Hours for 7 weeks of data to finish K- running and 9 weeks to repeat the experiment with a K+ beam and a deuterium target	
	Approval	16 Mar, 78 600 Hours with conditions before the Meson Laboratory pause 21 Dec, 78 1,800 Hours with the approval of an additional 7 weeks of running to finish K- data; no commitment is made to K+ running	
	Completed	16 Mar, 81 3,150 Hours	
591	PARTICLE SEARCH #591 BEAM: Internal Target Area (C-0) BROAD SEARCH FOR NEW HADRONIC STATES VIA HIGH RESOLUTION CHARGE AND MASS DETERMINATION OF NUCLEAR FRAGMENTS.	Laszlo J. Gutay	FERMILAB PURDUE UNIVERSITY
	Request	31 Jan, 78 800 Hours to include 200 hours for setup and 600 hours for data	
	Approval	21 Apr, 78 800 Hours	
	Completed	8 Feb, 81 1,950 Hours	
592	NUCLEAR SCALING #592 BEAM: Proton Area - West PROPOSAL FOR EXPERIMENTAL STUDY OF THE RELATIONSHIP BETWEEN HADRONIC AND NUCLEAR SCALING AT VERY HIGH ENERGIES.	Sherman Frankel	ITEP, MOSCOW (RUSSIA) UNIVERSITY OF PENNSYLVANIA COLLEGE OF WILLIAM AND MARY
	Request	31 Jan, 78 300 Hours to be run in a 400 GeV proton beam at an upstream location in P-West	
	Approval	17 Mar, 78 300 Hours to be run in such a manner as not to interfere with the installation of the P-West pion beam	
	Completed	17 Jul, 78 500 Hours	
594	NEUTRINO #594 BEAM: Neutrino Area - Dichromatic PROPOSAL FOR A NEW NEUTRINO DETECTOR AT FERMILAB.	James K. Walker	FERMILAB ILLINOIS INSTITUTE OF TECHNOLOGY MASSACHUSETTS INST. OF TECHNOLOGY MICHIGAN STATE UNIVERSITY NORTHERN ILLINOIS UNIVERSITY
	Request	1 Feb, 78 2,500 Hours for data to include: Experiment A (a study of semi-leptonic neutral current reactions) to require 6 x 10 to the 18th protons utilizing the narrow band beam at 250 GeV Experiment B (neutrino electron elastic scattering) to require 6 x 10 to the 18th protons utilizing the two-horn beam	
	Approval	16 Mar, 78 Unspecified	
	Completed	14 Jun, 82 4,400 Hours	
595	PARTICLE SEARCH #595 BEAM: Neutrino Area - 15 ft. Hadron Beam A STUDY OF CHARM AND OTHER NEW FLAVORS PRODUCED IN PION-NUCLEON COLLISIONS. (Continuation of work begun in exp #379.)	Arie Bodek	CALIFORNIA INSTITUTE OF TECHNOLOGY UNIVERSITY OF CHICAGO FERMILAB UNIVERSITY OF ROCHESTER STANFORD UNIVERSITY
	Request	1 Feb, 78 1,000 Hours to include 400 hours at 300 GeV with an incident intensity of 10 to the 5th pi- per pulse and 400 hours at 250-300 GeV with incident intensity of 10 to the 6th pi- per pulse	
	Approval	29 Jun, 78 600 Hours for the low-pt part of the experiment	
	Completed	16 Jun, 80 1,450 Hours	
596	PARTICLE SEARCH #596 BEAM: Neutrino Area - Muon/Hadron Beam ON SEARCHING FOR HEAVY STABLE PARTICLES (A continuation of work begun with exp #187.)	Leon M. Lederman	COLUMBIA UNIVERSITY FERMILAB SUNY AT STONY BROOK
	Request	3 Feb, 78 150 Hours to be run with the beam tuned to 75 GeV and assuming 10 to the 13th primary protons incident per pulse	
	Approval	1 May, 78 150 Hours	
	Completed	21 May, 78 200 Hours	
597	30-INCH HYBRID #597 BEAM: Neutrino Area - 30 in. Hadron Beam PROPOSAL FOR A HIGH STATISTICS STUDY OF PBAR-P ANNIHILATIONS AND A COMPARISON OF PBAR, P, PI+-, AND K+ INTERACTIONS ON HYDROGEN, MAGNESIUM, AND GOLD AT 100 GEV/C UTILIZING THE FERMILAB 30-INCH HYDROGEN BUBBLE CHAMBER. (The use of thin metallic foil targets in the hydrogen is requested.)	James J. Whitmore	UNIVERSITY OF CAMBRIDGE (ENGLAND) DUKE UNIVERSITY FERMILAB UNIVERSITY OF KANSAS MICHIGAN STATE UNIVERSITY NOTRE DAME UNIVERSITY
	Request	3 Feb, 78 1,450 K Pix to be taken as follows- 1,000K pix in negative beam @ 100 GeV 400K pix in positive beam @ 100 GeV 50K pix in negative beam @ 360 GeV	
	Approval	16 Mar, 78 1,000 Hours for a run of 10 weeks duration	
	Completed	3 May, 82 658 K Pix	
605	HIGH MASS PAIRS #605 BEAM: Meson Area - East A STUDY OF LEPTONS AND HADRONS NEAR THE KINEMATIC LIMITS. (Using an apparatus with higher luminosity and acceptance than experiment #288.)	John P. Rutherford	CEN-SACLAY (FRANCE) CERN (SWITZERLAND) COLUMBIA UNIVERSITY FERMILAB KEK (JAPAN) KYOTO UNIVERSITY (JAPAN) SUNY AT STONY BROOK UNIVERSITY OF WASHINGTON
	Request	9 May, 78 4,000 Hours to be run with an incident intensity greater than 10 to the 13th protons/pulse at an energy of at least 400 GeV 28 Nov, 78 4,000 Hours in the Phase I configuration. an incident beam of 400 GeV protons would be needed with an intensity of 3 x 10 to the 12th per pulse	
	Approval	19 Mar, 79 1,000 Hours with the Phase I detector	
	Completed	29 Aug, 85 3,970 Hours	

608	PARTICLE SEARCH #608 BEAM: Proton Area - Center A SEARCH FOR THE ETA SUB C IN HADRONIC INTERACTIONS. (Using the spectrometer from exp #288/494.)	Charles N. Brown	COLUMBIA UNIVERSITY FERMILAB SUNY AT STONY BROOK
	Request	28 Sep, 78	100 Hours in the P-center proton beam at an incident intensity of 3×10 to the 9th protons per pulse
	Approval	25 Jan, 79	Parasitic Running
	Completed	7 Mar, 79	600 Hours
609	HADRON JETS #609 BEAM: Meson Area - M6 Beam A STUDY OF THE STRUCTURE OF HIGH P TRANSVERSE HADRONIC INTERACTIONS. (This proposal supersedes P-246.)	Walter Selove	ARGONNE NATIONAL LABORATORY FERMILAB LEHIGH UNIVERSITY UNIVERSITY OF PENNSYLVANIA RICE UNIVERSITY UNIVERSITY OF WISCONSIN - MADISON
	Request	2 Oct, 78	1,500 Hours for Phase 1 to be run in a beam with 400 GeV capability with at least 10 to the 8th protons per sec incident Phase 2 would include addition of a large aperture magnet, Cerenkov imaging device and PWC's; Phase 3 would include a request for a higher energy beam
	Approval	16 Nov, 78	Unspecified with conditions
		30 Jan, 80	1,500 Hours
	Completed	14 Feb, 84	620 Hours
610	PARTICLE SEARCH #610 BEAM: Neutrino Area - Muon/Hadron Beam PION PRODUCTION OF HEAVY QUARK MESON STATES DECAYING INTO THE PSI/J (3097). (Continuation of work begun in exp #369 but with upgraded cyclotron spectrometer.)	Thomas B. W. Kirk	FERMILAB HOWARD UNIVERSITY UNIVERSITY OF ILLINOIS, CHAMPAIGN UNIVERSITY OF PENNSYLVANIA PURDUE UNIVERSITY TUFTS UNIVERSITY
	Request	2 Oct, 78	1,000 Hours to be run with an incident intensity of 10 to the 13th protons per pulse on the production target
	Approval	21 Dec, 78	1,000 Hours with a schedule yet to be formally determined
	Completed	23 Jun, 80	1,250 Hours see proposal #673
612	PHOTON DISSOCIATION #612 BEAM: Proton Area - East A PROPOSAL TO MEASURE THE DIFFRACTIVE PHOTON DISSOCIATION ON HYDROGEN.	Konstantin Goulianos	ROCKEFELLER UNIVERSITY
	Request	2 Oct, 78	1,150 Hours to be run in the tagged photon beam with 10 to the 6th incident photons per pulse
	Approval	15 Nov, 78	1,150 Hours
	Completed	12 Apr, 82	1,850 Hours
613	BEAM DUMP #613 BEAM: Meson Area - M2 Beam PROPOSAL FOR A PROMPT NEUTRINO EXPERIMENT AT FERMILAB.	Byron P. Roe	UNIVERSITY OF FIRENZE (ITALY) UNIVERSITY OF MICHIGAN - ANN ARBOR OHIO STATE UNIVERSITY UNIVERSITY OF WISCONSIN - MADISON
	Request	2 Oct, 78	1,000 Hours to obtain an exposure of $1 - 2 \times 10$ to the 17th protons with an incident intensity of 1×10 to the 12th protons/pulse
	Approval	15 Nov, 78	1,000 Hours with an expected reassessment of physics priorities and possible implications for this experiment in the fall of 1979
	Completed	13 May, 82	1,800 Hours
615	FORWARD SEARCH #615 BEAM: Proton Area - West A STUDY OF THE FORWARD PRODUCTION OF MASSIVE PARTICLES. IN PHASE ONE THE FORWARD PRODUCTION OF MUON PAIRS WOULD BE STUDIED. (Using a forward spectrometer with mass selection.)	Kirk T. McDonald	UNIVERSITY OF CHICAGO FERMILAB IOWA STATE UNIVERSITY PRINCETON UNIVERSITY
	Request	28 Nov, 78	1,000 Hours to be run in a 50-GeV pion beam at an incident intensity of 10 to the 10th pions per pulse
		7 May, 79	1,000 Hours to include 600 hours of running with 250 GeV pions and 200 hours with 75 GeV pions. A primary proton intensity of 10 to the 13th per pulse on the P-West production target and 300 pulses per hour are assumed.
	Approval	1 Jul, 79	1,000 Hours
	Completed	14 Jul, 84	2,260 Hours
616	NEUTRINO #616 BEAM: Neutrino Area - Dichromatic PROPOSAL TO MEASURE NEUTRINO STRUCTURE FUNCTIONS. (Use of the Lab E neutrino detector to continue work begun in exp #356.)	Frank J. Sciulli	CALIFORNIA INSTITUTE OF TECHNOLOGY COLUMBIA UNIVERSITY FERMILAB UNIVERSITY OF ROCHESTER ROCKEFELLER UNIVERSITY
	Request	29 Jan, 79	3,200 Hours to include specifically 600 hours for checkout, calibration and background studies, and 2×10 to the 19th protons at 400 GeV for data
	Approval	19 Mar, 79	4,000 Hours approximately or 2×10 to the 19th protons to be combined with running for exp #356
	Completed	22 Jan, 80	2,900 Hours
617	CP VIOLATION #617 BEAM: Meson Area - M3 Beam A STUDY OF DIRECT CP VIOLATION IN THE DECAY OF THE NEUTRAL KAON VIA A PRECISION MEASUREMENT OF THE RATIO OF ETA 00 TO ETA +/-.	Bruce D. Winstein	CEN-SACLAY (FRANCE) UNIVERSITY OF CHICAGO
	Request	30 Jan, 79	1,000 Hours for data
	Approval	19 Mar, 79	1,000 Hours
	Completed	14 Jun, 82	2,300 Hours

619	TRANSITION MAGNETIC MOMENT #619 BEAM: Proton Area - Center A MEASUREMENT OF THE SIGMA-ZERO TO LAMBDA TRANSITION MAGNETIC MOMENT.	Thomas J. Devlin	UNIVERSITY OF MICHIGAN - ANN ARBOR UNIVERSITY OF MINNESOTA RUTGERS UNIVERSITY UNIVERSITY OF WISCONSIN - MADISON
	Request	7 May, 79	250 Hours to be run in the diffracted proton beam (normally 400 GeV) at an intensity between 10 to the 8th and 10 to the 9th protons per pulse with a 1-sec spill
	Approval	1 Jul, 79	250 Hours
	Completed	14 Jun, 82	675 Hours
620	CHARGED HYPERON MAG MOMENT #620 BEAM: Meson Area - M2 Beam PROPOSAL TO MEASURE THE MAGNETIC MOMENTS OF THE SIGMA +, SIGMA -, XI -, AND OMEGA - HYPERONS USING THE FERMILAB NEUTRAL HYPERON BEAM.	Lee G. Pondrom	UNIVERSITY OF MICHIGAN - ANN ARBOR UNIVERSITY OF MINNESOTA RUTGERS UNIVERSITY UNIVERSITY OF WISCONSIN - MADISON
	Request	7 May, 79	300 Hours to be run in the diffracted proton beam (350 to 400 GeV) at an intensity of 10 to the 9th protons per pulse and a 1-sec spill
	Approval	1 Jul, 79	300 Hours
	Completed	22 Jan, 80	900 Hours
621	CP VIOLATION #621 BEAM: Proton Area - Center A MEASUREMENT OF THE CP VIOLATION PARAMETER ETA +-0. (Use of the neutral hyperon spectrometer is assumed.)	Gordon B. Thomson	UNIVERSITY OF MICHIGAN - ANN ARBOR UNIVERSITY OF MINNESOTA RUTGERS UNIVERSITY
	Request	7 May, 79	1,200 Hours to be run in 2 phases consisting of 200 hours for Phase 1 with some modifications to the present apparatus 1000 hours for Phase 2 at a later date after results from Phase 1 have been analyzed
	Approval	1 Jul, 81	Unspecified
	Completed	29 Aug, 85	2,470 Hours
622	QUARK #622 BEAM: Meson Area - M2 Beam PROPOSAL TO SEARCH FOR FRACTIONAL CHARGE PARTICLES FROM A MAGNETIZED BEAM DUMP.	H. Richard Gustafson	UNIVERSITY OF MICHIGAN - ANN ARBOR
	Request	7 May, 79	100 Hours to be run partially in conjunction with exp #361 using the beam dump from that experiment
	Approval	1 Jul, 79	Parasitic Running in a mode that is not to interfere with the operation of exp #361
	Completed	23 Jun, 80	Unspecified
623	PARTICLE SEARCH #623 BEAM: Meson Area - M6 Beam PROPOSAL TO STUDY HIGH MASS STATES DECAYING INTO PHI-PI AND PHI-PHI PAIRS PRODUCED CENTRALLY IN 300 GEV/C PI MINUS PROTON INTERACTIONS. (Use of the Fermilab multiparticle spectrometer facility is assumed.)	Daniel R. Green	UNIVERSITY OF ARIZONA FERMILAB FLORIDA STATE UNIVERSITY NOTRE DAME UNIVERSITY TUFTS UNIVERSITY VANDERBILT UNIVERSITY VIRGINIA TECH
	Request	7 May, 79	1,000 Hours to be run in a 300 GeV/c beam of negative pions at an intensity of a few times 10 to the 6th pions per pulse
	Approval	14 Nov, 80	500 Hours to be run before 1983
	Completed	14 Jun, 82	425 Hours
629	DIRECT PHOTON PRODUCTION #629 BEAM: Meson Area - M1 Beam DIRECT PHOTON PRODUCTION IN HADRON NUCLEUS COLLISIONS.	Charles A. Nelson, Jr.	FERMILAB MICHIGAN STATE UNIVERSITY UNIVERSITY OF MINNESOTA NORTHEASTERN UNIVERSITY UNIVERSITY OF ROCHESTER TEXAS A&M UNIVERSITY
	Request	25 Feb, 80	600 Hours to include 200 hrs for set up, 400 hrs for data
	Approval	7 Jul, 80	Unspecified approved as a test in the M-1 beam line in the fall of 1980
	Completed	9 Mar, 81	600 Hours
630	CHARM PARTICLE #630 BEAM: Proton Area - Center STUDY OF B PARTICLE AND CHARMED PARTICLE PRODUCTION AND DECAY USING A HIGH RESOLUTION STREAMER CHAMBER.	Jack Sandweiss	FERMILAB LAWRENCE BERKELEY LABORATORY YALE UNIVERSITY
	Request	26 Feb, 80	600 Hours
	Approval	15 Mar, 80	600 Hours
	Completed	15 Mar, 82	1,150 Hours
631	NUC CALIBRATION CROSS SECT #631 BEAM: Neutrino Area - Miscellaneous A MEASUREMENT OF NUCLEAR CALIBRATION CROSS SECTIONS FOR PROTONS BETWEEN 100 AND 1000 GEV.	Samuel I. Baker	BROOKHAVEN NATIONAL LABORATORY CERN (SWITZERLAND) FERMILAB
	Request	26 Feb, 80	25 Exposure(s)
	Approval	15 Dec, 80	Unspecified in neutrino area
	Completed	1 Jun, 81	41 Exposure(s)

632	15-FT NEUTRINO/H2 & NE #632 BEAM: Neutrino Area - Center AN EXPOSURE OF THE 15-FOOT BUBBLE CHAMBER WITH A NEON-HYDROGEN MIXTURE TO A WIDEBAND NEUTRINO BEAM FROM THE TEVATRON.	Douglas R. O. Morrison and Michael W. Peters	UNIVERSITY OF BIRMINGHAM (ENGLAND) UNIV. OF CALIFORNIA, BERKELEY CEN-SACLAY (FRANCE) CERN (SWITZERLAND) FERMILAB UNIVERSITY OF HAWAII AT MANOA ILLINOIS INSTITUTE OF TECHNOLOGY IMPERIAL COLLEGE (ENGLAND) JAMMU UNIVERSITY (INDIA) UNIVERSITY OF LIBRE (BELGIUM) MAX-PLANCK INSTITUTE (GERMANY) MOSCOW STATE UNIVERSITY (RUSSIA) ITEP, MOSCOW (RUSSIA) UNIVERSITY OF OXFORD (ENGLAND) PANJAB UNIVERSITY (INDIA) IHEP, PROTIVNO (SERPUKHOV) (RUSSIA) RUTGERS UNIVERSITY TUFTS UNIVERSITY
	Request	25 Apr, 80	250 K Pix
	Approval	18 Jun, 82	1 E18th Protons Stage I approval
		15 Dec, 83	1 E18th Protons Stage II approval
	Completed	1 Feb, 88	446 K Pix
635	NEUTRINO #635 BEAM: Neutrino Area - Prompt Beam PROPOSAL TO MEASURE MUON NEUTRINO ELECTRON AND MUON ANTI-NEUTRINO ELECTRON ELASTIC SCATTERING, NEUTRINO OSCILLATIONS, AND DECAYS OF LONG-LIVED NEUTRAL PARTICLES AT THE TEVATRON OF FERMILAB.	Luke W. Mo	FERMILAB VIRGINIA TECH
	Request	25 Apr, 80	... 3 x 10 to the 18th protons
		16 Mar, 83	Unspecified
	Approval	12 Nov, 83	Unspecified Stage I approval.
	Approved/Inactive	1 Feb, 88	Unspecified
636	BEAM DUMP #636 BEAM: Neutrino Area - Prompt Beam NEUTRINO INTERACTION STUDIES WITH A HEAVY LIQUID BUBBLE CHAMBER AT TEVATRON ENERGIES USING A BEAM DUMP TECHNIQUE TO PRODUCE THE NEUTRINO BEAM.	Toshio Kitagaki and Irwin A. Pless	IHEP, BEIJING (PRC) BROWN UNIVERSITY FERMILAB INDIANA UNIVERSITY MASSACHUSETTS INST. OF TECHNOLOGY OAK RIDGE NATIONAL LABORATORY TECHNION-ISRAEL INST (ISRAEL) UNIVERSITY OF TEL-AVIV (ISRAEL) UNIVERSITY OF TENNESSEE, KNOXVILLE TOHOKU GAKUIN UNIVERSITY (JAPAN) TOHOKU UNIVERSITY (JAPAN)
	Request	25 Apr, 80	2.5 E18th Protons
	Approval	14 Nov, 80	Unspecified
	Approved/Inactive	1 Feb, 88	Unspecified
646	15-FT BEAM DUMP #646 BEAM: Neutrino Area - Prompt Beam SEARCH FOR THE TAU NEUTRINO AND STUDY OF ELECTRON NEUTRINO AND ELECTRON ANTI-NEUTRINO INTERACTIONS.	Michael W. Peters	UNIV. OF CALIFORNIA, BERKELEY FERMILAB UNIVERSITY OF HAWAII AT MANOA ILLINOIS INSTITUTE OF TECHNOLOGY RUTGERS UNIVERSITY STEVENS INSTITUTE OF TECHNOLOGY TUFTS UNIVERSITY
	Request	25 Apr, 80	2 E18th Protons
	Approval	1 Jul, 81	Unspecified
	Approved/Inactive	1 Feb, 88	Unspecified
650	PARTICLE SEARCH #650 BEAM: Proton Area - West REQUEST FOR A CONTINUATION OF E-567.	Robert C. Webb	BROOKHAVEN NATIONAL LABORATORY CEN-SACLAY (FRANCE) PRINCETON UNIVERSITY TEXAS A&M UNIVERSITY UNIVERSITY OF TORINO (ITALY)
	Request	29 Apr, 80	500 Hours
	Approval	7 Jul, 80	500 Hours expected to run in the spring 1981 running period.
	Completed	29 Dec, 80	550 Hours
653	PARTICLE SEARCH #653 BEAM: Neutrino Area - East A PROPOSAL TO MEASURE CHARM AND B DECAYS VIA HADRONIC PRODUCTION IN A HYBRID EMULSION SPECTROMETER.	Neville W. Reay	AICHI UNIV. OF EDUCATION (JAPAN) UNIV. OF CALIFORNIA, DAVIS CARNEGIE-MELLON UNIVERSITY CHONNAM NATIONAL UNIVERSITY (KOREA) FERMILAB GIFU UNIVERSITY (JAPAN) GYEONGSANG NATIONAL UNIV. (KOREA) KINKI UNIVERSITY (JAPAN) KOBE UNIVERSITY (JAPAN) KOREA UNIVERSITY, SEOUL (KOREA) NAGOYA INST. OF TECHNOLOGY (JAPAN) NAGOYA UNIVERSITY (JAPAN) OHIO STATE UNIVERSITY OKAYAMA UNIVERSITY (JAPAN) UNIVERSITY OF OKLAHOMA OSAKA CITY UNIVERSITY (JAPAN) OSAKA SCIENCE EDUC. INST. (JAPAN) TOHO UNIVERSITY (JAPAN) UTSUNOMIYA UNIVERSITY (JAPAN) WON KWANG UNIVERSITY, IRI (KOREA)
	Request	1 May, 80	1,500 Hours
	Approval	1 Jul, 81	Unspecified
	Completed	15 Feb, 88	1,800 Hours
660	CHANNELING #660 BEAM: Meson Area - M4 Beam PROPOSAL TO STUDY THE EFFECT OF BENT CRYSTALS ON CHANNELING NEAR THE CRITICAL RADIUS OF BENDING.	Walter M. Gibson	CERN (SWITZERLAND) CHALK RIVER NUCLEAR LAB. (CANADA) FERMILAB JINR, DUBNA (RUSSIA) UNIVERSITY OF NEW MEXICO SUNY AT ALBANY UNIVERSITY OF STRASBOURG (FRANCE)
	Request	10 Jun, 80	300 Hours
	Approval	14 Nov, 80	400 Hours
	Completed	13 Jun, 82	425 Hours
663	LAMBDA POLARIZATION #663 BEAM: Meson Area - M4 Beam COMPARISON OF POLARIZATION OF INCLUSIVELY PRODUCED LAMBDA AND ANTILAMBDA BY PROTONS, ANTI-PROTONS, KAONS AND PIONS ON HYDROGEN.	Hans G. E. Kobrak	UNIV. OF CALIFORNIA, DAVIS UNIV. OF CALIFORNIA, SAN DIEGO CARELTON UNIVERSITY (CANADA) FERMILAB MICHIGAN STATE UNIVERSITY
	Request	29 Sep, 80	1,000 Hours
	Approval	14 Nov, 80	800 Hours must be completed by July 1, 1981
	Completed	1 Jun, 81	500 Hours

665	TEVATRON MUON #665 BEAM: Neutrino Area - Muon Beam MUON SCATTERING WITH HADRON DETECTION AT THE TEVATRON.	Heidi M. Schellman	ARGONNE NATIONAL LABORATORY UNIV. OF CALIFORNIA, SAN DIEGO FERMILAB FREIBURG UNIVERSITY (GERMANY) HARVARD UNIVERSITY UNIV. OF ILLINOIS, CHICAGO CIRCLE INP, KRAKOW (POLAND) LAWRENCE LIVERMORE LABORATORY UNIVERSITY OF MARYLAND MASSACHUSETTS INST. OF TECHNOLOGY MAX-PLANCK INSTITUTE (GERMANY) NORTHWESTERN UNIVERSITY OHIO UNIVERSITY UNIVERSITY OF PENNSYLVANIA UNIVERSITY OF WASHINGTON UNIVERSITY OF WUPPERTAL (GERMANY) YALE UNIVERSITY
	Request	3 Oct, 80	3,000 Hours
	Approval	1 Jul, 81	1,000 Hours
		30 Jan, 89	... Tracking system upgrade
	Data Analysis	8 Jan, 92	Unspecified
	Completed	1 Mar, 99	Unspecified
666	EMULSION EXPOSURE #666 BEAM: Proton Area - Center EMULSION EXPOSURE TO SIGMA MINUS BEAM AT FERMILAB.	Richard J. Wilkes	INP, KRAKOW (POLAND) UNIVERSITY OF WASHINGTON
	Request	2 Dec, 80	1 K Pix
	Approval	2 Dec, 80	Unspecified
	Completed	9 Mar, 81	6 Stack(s)
667	EMULSION/PI- @ 500 #667 BEAM: Proton Area - East STUDY OF PION-NUCLEUS INTERACTIONS IN PURE EMULSION STACKS AND EMULSION CHAMBERS AT ENERGY ABOVE 500 GEV.	Wladyslaw Wolter	INP, KRAKOW (POLAND) LEBEDEV PHYSICAL INST. (RUSSIA) LOUISIANA STATE UNIVERSITY TASHKENT, PHY.TEC.INS (UZBEKISTAN)
	Request	2 Dec, 80	Emulsion Exposure
	Approval	28 Mar, 90	Unspecified
	Completed	27 Aug, 90	Unspecified
668	EMULSION/PI- @ 800 #668 BEAM: Unspecified Beam STUDY OF PION NUCLEUS INTERACTIONS IN PURE EMULSION STACKS AND EMULSION CHAMBERS AT ENERGY ABOVE 800 GEV.	Wladyslaw Wolter	INP, KRAKOW (POLAND)
	Request	2 Dec, 80	Emulsion Exposure
	Completed	26 Apr, 85	Emulsion Exposure
672A	HADRON JETS #672A BEAM: Meson Area - West A STUDY OF HADRONIC FINAL STATES PRODUCED IN ASSOCIATION WITH HIGH-PT JETS AND HIGH-MASS DIMUONS.	Andrzej Zieminski	FERMILAB UNIV. OF ILLINOIS, CHICAGO CIRCLE INDIANA UNIVERSITY UNIVERSITY OF LOUISVILLE UNIVERSITY OF MICHIGAN - FLINT IHEP, PROTIVNO (SERPUKHOV) (RUSSIA)
	Request	1 Feb, 81	2,000 Hours for data taking plus 500 hours for setup and testing
	Approval	1 Jul, 81	Unspecified
	Data Analysis	8 Jan, 92	Unspecified
	Completed	1 Mar, 99	Unspecified
673	CHI MESON #673 BEAM: Neutrino Area - Muon/Hadron Beam CHI MESON PRODUCTION BY HADRONS. (E-610 extension.)	John W. Cooper	FERMILAB UNIVERSITY OF ILLINOIS, CHAMPAIGN UNIVERSITY OF PENNSYLVANIA PURDUE UNIVERSITY TUFTS UNIVERSITY
	Request	1 Feb, 81	1,500 Hours to be run with Dichromatic train during the fall 1981 period
	Approval	1 Jul, 81	Unspecified
	Completed	14 Apr, 82	1,100 Hours
683	PHOTOPRODUCTION OF JETS #683 BEAM: Proton Area - Broad Band PHOTOPRODUCTION OF HIGH PT JETS.	Marjorie D. Corcoran	BALL STATE UNIVERSITY FERMILAB UNIVERSITY OF IOWA UNIVERSITY OF MARYLAND UNIVERSITY OF MICHIGAN - ANN ARBOR RICE UNIVERSITY VANDERBILT UNIVERSITY
	Request	1 Feb, 81	1,200 Hours including 500 hours for tune-up, calibration and some hadron beam running
	Approval	15 Dec, 83	Unspecified Stage I approval.
		4 Apr, 87	Unspecified Stage II approval.
	Data Analysis	8 Jan, 92	Unspecified
	Completed	1 Mar, 99	Unspecified
687	PHOTOPRODUCTION OF CHARM AND B #687 BEAM: Proton Area - Broad Band HIGH ENERGY PHOTOPRODUCTION OF STATES CONTAINING HEAVY QUARKS AND OTHER RARE PHENOMENA.	Joel N. Butler and John P. Cumalat	UNIV. OF CALIFORNIA, DAVIS UNIVERSITY OF COLORADO AT BOULDER FERMILAB INFN, FRASCATI (ITALY) UNIVERSITY OF ILLINOIS, CHAMPAIGN INFN, MILANO (ITALY) UNIVERSITY OF MILANO (ITALY) UNIVERSITY OF NORTH CAROLINA NORTHWESTERN UNIVERSITY NOTRE DAME UNIVERSITY UNIVERSITY OF PAVIA (ITALY) UNIV. OF PUERTO RICO - RIO PIEDRAS
	Request	1 Feb, 81	2,000 Hours including a 500 hour run with a thick target and a beam dump and another 1500 hour run with an open geometry
	Approval	1 Jul, 81	Unspecified Stage I approval.
		15 Dec, 83	Unspecified Stage II approval.
	Data Analysis	8 Jan, 92	Unspecified
	Completed	1 Mar, 99	Unspecified

690	PARTICLE SEARCH #690 BEAM: Neutrino Area - East STUDY OF HADRONIC PRODUCTION AND SPECTROSCOPY OF STRANGE, CHARM AND BOTTOM PARTICLES AT THE TEVATRON.	Bruce C. Knapp	COLUMBIA UNIVERSITY FERMILAB UNIVERSITY OF GUANAJUATO (MEXICO) UNIVERSITY OF MASSACHUSETTS TEXAS A&M UNIVERSITY
	+-----+		
	Request	1 Feb, 81	1,400 Hours including 400 hours of target fragmentation measurements during installation and 1000 hours with full detector
	Approval	1 Jul, 81	Unspecified
		12 Nov, 83	Unspecified Stage I approval.
		4 Apr, 87	Unspecified Stage II approval.
		8 Jan, 92	Unspecified
	Data Analysis	8 Jan, 92	Unspecified
	Completed	1 Mar, 99	Unspecified
691	TAGGED PHOTON #691 BEAM: Proton Area - East PROPOSAL TO DO PHOTON PHYSICS WITH THE TEVATRON AT THE TAGGED PHOTON SPECTROMETER.	Michael S. Witherell	UNIV. OF CALIFORNIA, SANTA BARBARA CARELTON UNIVERSITY (CANADA) CBPF (BRAZIL) UNIVERSITY OF COLORADO AT BOULDER FERMILAB NATIONAL RESEARCH COUNCIL (CANADA) UNIVERSITY OF OKLAHOMA UNIVERSITE OF SAO PAULO (BRAZIL) UNIVERSITY OF TORONTO (CANADA)
	+-----+		
	Request	1 Feb, 81	1,000 Hours
	Approval	12 Nov, 83	Unspecified Stage I approval
	Completed	29 Aug, 85	1,400 Hours
700	NEUTRINO OSCILLATION #700 BEAM: Neutrino Area - Prompt Beam STUDY OF NEUTRINO OSCILLATIONS AND SEARCH FOR THE TAU NEUTRINO.	David J. Miller	UNIVERSITY OF BARI (ITALY) ECOLE POLYTECH, PALAISEAU (FRANCE) ILLINOIS INSTITUTE OF TECHNOLOGY LONDON UNIVERSITY COLLEGE (ENGLAND) TUFTS UNIVERSITY
	+-----+		
	Request	10 Feb, 81	2.5 E18th Protons
	Inactive	1 Apr, 84	
701	NEUTRINO OSCILLATION #701 BEAM: Neutrino Area - Dichromatic A SEARCH FOR NEUTRINO OSCILLATIONS WITH DELTA-M-SQUARE GREATER THAN 10 EV-SQUARE.	Michael H. Shaevitz	UNIVERSITY OF CHICAGO COLUMBIA UNIVERSITY FERMILAB UNIVERSITY OF ROCHESTER
	+-----+		
	Request	12 Feb, 81	5.2 E18th Protons
	Approval	1 Jul, 81	Unspecified
	Completed	14 Jun, 82	2,250 Hours
702	PARTICLE SEARCH #702 BEAM: Internal Target Area (C-0) SEARCH FOR PARTICLES WITH ANOMALOUS VALUES OF M/Q AND EXTREMELY SHORT INTERACTION LENGTHS (A REVISION OF P-607). (To use recoil spectrometer with rotating be wire filament target.)	George Glass	IHEP, BEIJING (PRC) FERMILAB NORTHEASTERN UNIVERSITY TEXAS A&M UNIVERSITY
	+-----+		
	Request	12 Jun, 81	400 Hours for data and approximately 3 months to build and debug the apparatus
	Inactive	1 Apr, 84	
703	ELECTRON TARGET FACILITY #703 BEAM: Collision Area (D-0) ELECTRON-PROTON COLLISIONS AT FERMILAB (Electron-proton collisions using the canadian high energy electron ring cheer.)	William R. Frisken	CIPP (CANADA) CARELTON UNIVERSITY (CANADA) CEN-SACLAY (FRANCE) CHALK RIVER NUCLEAR LAB. (CANADA) UNIVERSITY OF CHICAGO CORNELL UNIVERSITY FERMILAB UNIVERSITY OF MARYLAND MCGILL UNIVERSITY (CANADA) NATIONAL RESEARCH COUNCIL (CANADA) UNIVERSITY OF SASKATCHEWAN (CANADA) UNIVERSITY OF TORONTO (CANADA) TRIUMF (CANADA) YORK UNIVERSITY (CANADA)
	+-----+		
	Request	6 Jul, 81	1,000 Hours initial run to obtain 1 x 10 to the 4th inverse nanobarns. plus several later runs totalling 10 to the 6th inverse nanobarns
	Inactive	23 Jun, 82	
704	POLARIZED BEAM #704 BEAM: Meson Area - Polarized Proton Beam INTEGRATED PROPOSAL ON FIRST ROUND EXPERIMENTS WITH THE POLARIZED BEAM FACILITY.	Akihiko Yokosawa	ARGONNE NATIONAL LABORATORY CEN-SACLAY (FRANCE) FERMILAB HIROSHIMA UNIVERSITY (JAPAN) UNIVERSITY OF IOWA KYOTO SANGYO UNIVERSITY (JAPAN) KYOTO UNIVERSITY (JAPAN) KYOTO UNIV. OF EDUCATION (JAPAN) LAPP, D'ANNECY-LE-VIEUX (FRANCE) LOS ALAMOS NATIONAL LABORATORY NORTHWESTERN UNIVERSITY UN. OF OCCUP. & ENV. HEALTH (JAPAN) IHEP, PROTIVNO (SERPUKHOV) (RUSSIA) RICE UNIVERSITY UNIVERSITY DI TRIESTE (ITALY) UNIVERSITY OF UDINE (ITALY)
	+-----+		
	Request	8 Sep, 81	1,200 Hours proposal to perform simultaneously substantial parts of experiments described in P676, P678, P674 and P677.
	Approval	14 Dec, 81	Unspecified Stage I approval.
		15 Dec, 83	1,200 Hours Stage II approval.
	Data Analysis	13 Aug, 90	Unspecified
	Completed	1 Mar, 99	Unspecified

705	CHI MESON #705 BEAM: Proton Area - West A STUDY OF CHARMONIUM AND DIRECT PHOTON PRODUCTION BY 300 GEV/C ANTIPROTON, PROTON, PI+ AND PI- BEAMS.	Bradley B. Cox	UNIVERSITY OF SOUTH ALABAMA UNIVERSITY OF ARIZONA UNIVERSITY OF ATHENS (GREECE) DUKE UNIVERSITY FERMILAB UNIVERSITY OF FIRENZE (ITALY) MCGILL UNIVERSITY (CANADA) NANJING UNIVERSITY (PRC) NORTHWESTERN UNIVERSITY PRAIRIE VIEW A&M UNIVERSITY SHANDONG UNIVERSITY (PRC) SSC LABORATORY UNIVERSITY OF VIRGINIA
	Request	1 Oct, 81	1,500 Hours
	Approval	14 Dec, 81	1,500 Hours
	Completed	15 Feb, 88	3,600 Hours
706	DIRECT PHOTON PRODUCTION #706 BEAM: Meson Area - West A Comprehensive Study of Direct Photon Production in Hadron Induced Collisions	Paul F. Slattery	UNIV. OF CALIFORNIA, DAVIS DELHI UNIVERSITY (INDIA) FERMILAB MICHIGAN STATE UNIVERSITY NORTHEASTERN UNIVERSITY UNIVERSITY OF OKLAHOMA PENNSYLVANIA STATE UNIVERSITY UNIVERSITY OF PITTSBURGH UNIVERSITY OF ROCHESTER
	Request	26 Oct, 81	2,400 Hours
	Approval	14 Dec, 81	1,000 Hours
	Data Analysis	8 Jan, 92	Unspecified
	Completed	1 Mar, 99	Unspecified
707	SIGMA MINUS BETA DECAY #707 BEAM: Proton Area - Center MEASUREMENT OF THE ELECTRON ASYMMETRY PARAMETER IN SIGMA MINUS BETA DECAY.	Peter S. Cooper	UNIVERSITY OF CHICAGO FERMILAB IOWA STATE UNIVERSITY UNIVERSITY OF IOWA PNPI, ST. PETERSBURG (RUSSIA) YALE UNIVERSITY
	Request	24 Nov, 81	300 Hours
	Rejected	15 Dec, 81	
708	ELECTRON TARGET FACILITY #708 BEAM: Collision Area (D-0) ELECTRON-PROTON INTERACTION EXPERIMENT (Supercedes proposal #659.)	Wonyong Lee	ARGONNE NATIONAL LABORATORY BROOKHAVEN NATIONAL LABORATORY UNIVERSITY OF CHICAGO UNIVERSITY OF COLORADO AT BOULDER COLUMBIA UNIVERSITY FERMILAB HARVARD UNIVERSITY UNIVERSITY OF ILLINOIS, CHAMPAIGN UNIVERSITY OF MICHIGAN - ANN ARBOR NIKHEF-H (NETHERLANDS) UNIVERSITY OF PENNSYLVANIA PRINCETON UNIVERSITY ROCKEFELLER UNIVERSITY
	Request	25 Nov, 81	Unspecified
	Inactive	23 Jun, 82	
709	FORWARD DETECTOR #709 BEAM: Collision Area (D-0) PROPOSAL FOR A FORWARD DETECTOR FOR THE D0 AREA	Michael J. Longo	UNIV. OF ILLINOIS, CHICAGO CIRCLE UNIVERSITY OF MICHIGAN - ANN ARBOR
	Request	11 Jan, 82	Unspecified
	Rejected	23 Jun, 82	
710	TOTAL CROSS-SECTION #710 BEAM: Collision Area (E-0) MEASUREMENTS OF ELASTIC SCATTERING AND TOTAL CROSS SECTIONS AT THE FERMILAB PBAR-P COLLIDER.	Jay Orear and Roy Rubinstein	UNIVERSITY OF BOLOGNA (ITALY) CORNELL UNIVERSITY FERMILAB GEORGE MASON UNIVERSITY UNIVERSITY OF MARYLAND NORTHWESTERN UNIVERSITY
	Request	1 Feb, 82	Unspecified
	Approval	23 Jun, 82	Unspecified
	Completed	31 May, 89	Unspecified
711	CONSTITUENT SCATTERING #711 BEAM: Neutrino Area - East A PROPOSAL TO MEASURE THE ENERGY, ANGULAR, AND CHARGE DEPENDENCE OF MASSIVE DI-HADRON PRODUCTION OVER A LARGE SOLID ANGLE IN INTENSE PROTON AND PION BEAMS.	David A. Levinthal	ARGONNE NATIONAL LABORATORY FERMILAB FLORIDA STATE UNIVERSITY UNIVERSITY OF MICHIGAN - ANN ARBOR
	Request	28 Aug, 82	Unspecified
	Approval	1 Jul, 83	Unspecified
	Completed	15 Feb, 88	1,400 Hours
712	MUON PRODUCTION #712 BEAM: Collision Area (D-0) STUDY OF MUONS FROM PBAR-P COLLISIONS UP TO SQUARE ROOT OF S EQUAL TO 2 TEV.	Patrick D. Rapp	FERMILAB GEORGE MASON UNIVERSITY
	Request	1 Feb, 82	Unspecified
	Rejected	23 Jun, 82	
713	HIGHLY IONIZING PARTICLES #713 BEAM: Collision Area (D-0) PROPOSAL FOR A SEARCH FOR HIGHLY IONIZING PARTICLES FOR THE D0 AREA AT FERMILAB.	P. Buford Price	UNIV. OF CALIFORNIA, BERKELEY HARVARD UNIVERSITY
	Request	29 Jan, 82	Unspecified
	Approval	23 Jun, 82	Unspecified
	Completed	31 May, 89	Unspecified
714	LARGE ANGLE PARTICLE #714 BEAM: Collision Area (D-0) LARGE ANGLE PARTICLE D0 GROUP	Paul D. Grannis	BROOKHAVEN NATIONAL LABORATORY BROWN UNIVERSITY COLUMBIA UNIVERSITY FERMILAB MICHIGAN STATE UNIVERSITY SUNY AT STONY BROOK
	Request	5 Feb, 82	Unspecified
	Rejected	1 Jul, 83	
715	SIGMA BETA DECAY #715 BEAM: Proton Area - Center PRECISION MEASUREMENT OF THE DECAY SIGMA MINUS TO NEUTRON AND ELECTRON AND NEUTRINO.	Peter S. Cooper	UNIVERSITY OF CHICAGO ELMHURST COLLEGE FERMILAB IOWA STATE UNIVERSITY UNIVERSITY OF IOWA PNPI, ST. PETERSBURG (RUSSIA) YALE UNIVERSITY
	Request	19 Feb, 82	Unspecified
	Approval	23 Jun, 82	Unspecified for 3 months
	Completed	14 Feb, 84	820 Hours

716	BEAM DUMP #716 BEAM: Meson Area - M2 Beam PROPOSAL FOR FURTHER BEAM DUMP NEUTRINO RUNNING +-----+ Request 9 Feb, 82 Unspecified Rejected 23 Jun, 82	Byron P. Roe	FERMILAB UNIVERSITY OF FIRENZE (ITALY) UNIVERSITY OF MICHIGAN - ANN ARBOR UNIVERSITY OF WISCONSIN - MADISON
717	FORWARD DETECTOR #717 BEAM: Collision Area (D-0) A FORWARD LOOKING DETECTOR FOR THE D0 AREA. +-----+ Request 19 Mar, 82 Unspecified Rejected 23 Jun, 82	Joseph Lach	FERMILAB
718	CALORIMETERS AT D-0 #718 BEAM: Collision Area (D-0) STUDY OF PBAR-P INTERACTIONS USING CALORIMETERS AT D-0. +-----+ Request 1 Apr, 82 Unspecified Rejected 23 Jun, 82	Albert R. Erwin	ARGONNE NATIONAL LABORATORY UNIVERSITY OF ARIZONA FERMILAB UNIVERSITY OF PENNSYLVANIA UNIVERSITY OF WISCONSIN - MADISON
719	ELECTRON TARGET FACILITY #719 BEAM: Collision Area (D-0) ELECTRON-PROTON INTERACTION EXPERIMENT. (This proposal supercedes proposals #703 and #708.) +-----+ Request 14 May, 82 Unspecified Not Approved 23 Jun, 82	Wonyong Lee	ARGONNE NATIONAL LABORATORY CARELTON UNIVERSITY (CANADA) CEN-SACLAY (FRANCE) CHALK RIVER NUCLEAR LAB. (CANADA) UNIVERSITY OF COLORADO AT BOULDER COLUMBIA UNIVERSITY FERMILAB HARVARD UNIVERSITY UNIVERSITY OF ILLINOIS, CHAMPAIGN JOHNS HOPKINS UNIVERSITY UNIVERSITY OF MARYLAND MCGILL UNIVERSITY (CANADA) UNIVERSITY OF MICHIGAN - ANN ARBOR MICHIGAN STATE UNIVERSITY NIKHEF-H (NETHERLANDS) UNIVERSITY OF PENNSYLVANIA PRINCETON UNIVERSITY RICE UNIVERSITY ROCKEFELLER UNIVERSITY UNIVERSITY OF SASKATCHEWAN (CANADA) UNIVERSITY OF TORONTO (CANADA)
720	FREE QUARK SEARCH #720 BEAM: Miscellaneous Area PROPOSAL TO SEARCH FOR +1/3E STABLE PARTICLES USING CRYOGENIC SOURCES. +-----+ Request 29 Jan, 82 Unspecified Approval 15 Mar, 82 Unspecified for 3 months 2 Jun, 82 Unspecified Completed 8 Oct, 82 Unspecified	John P. Schiffer	ARGONNE NATIONAL LABORATORY FERMILAB
721	CP VIOLATION #721 BEAM: Proton Area - West AN EXPERIMENT TO STUDY CP VIOLATION IN THE DECAY OF K-LONG PRODUCED BY ANTI-PROTONS. +-----+ Request 11 Jun, 82 Unspecified Approval 12 Mar, 84 Test Running Approved/Inactive 30 Jun, 87 Unspecified	Jerome L. Rosen	UNIVERSITY OF ARIZONA UNIVERSITY OF ATHENS (GREECE) DUKE UNIVERSITY FERMILAB FLORIDA A&M UNIVERSITY MCGILL UNIVERSITY (CANADA) NORTHWESTERN UNIVERSITY SHANDONG UNIVERSITY (PRC)
722	D-0 STREAMER CHAMBER #722 BEAM: Collision Area (D-0) STREAMER CHAMBER EXPERIMENT AT THE TEVATRON COLLIDER. +-----+ Request 11 Oct, 82 Unspecified Inactive 18 Feb, 83	V. Paul Kenney	UNIVERSITY OF CAMBRIDGE (ENGLAND) NOTRE DAME UNIVERSITY
723	GRAVITATIONAL DETECTOR #723 BEAM: Collision Area (C-0) TEST OF A GRAVITATIONAL DETECTOR AT THE TEVATRON COLLIDER. +-----+ Request 21 Oct, 82 Unspecified Approval 12 Mar, 84 Test Running Completed 29 Aug, 85 Test Running	Adrian Melissinos	FERMILAB UNIVERSITY OF ROCHESTER
724	CALORIMETRIC DETECTOR #724 BEAM: Collision Area (D-0) COMPLETE CALORIMETRIC DETECTOR FOR THE D-0 AREA. +-----+ Request 26 Oct, 82 Unspecified Rejected 1 Jul, 83	Michael J. Longo	CALIFORNIA INSTITUTE OF TECHNOLOGY UNIV. OF ILLINOIS, CHICAGO CIRCLE MCGILL UNIVERSITY (CANADA) UNIVERSITY OF MICHIGAN - ANN ARBOR NOTRE DAME UNIVERSITY
725	DIFFRACTION DISSOCIATION #725 BEAM: Collision Area (D-0) A PROPOSAL TO MEASURE SINGLE AND DOUBLE DIFFRACTION DISSOCIATION AT THE FERMILAB PBAR-P COLLIDER. +-----+ Request 1 Nov, 82 Unspecified Rejected 1 Jul, 83	Konstantin Goulianos	ROCKEFELLER UNIVERSITY
726	CALORIMETRIC DETECTOR #726 BEAM: Collision Area (D-0) PROPOSED CALORIMETRIC DETECTOR FOR THE D-0 AREA. +-----+ Request 1 Nov, 82 Unspecified Rejected 1 Jul, 83	Maris A. Abolins	UNIVERSITY OF ARIZONA FERMILAB MICHIGAN STATE UNIVERSITY UNIVERSITY OF PENNSYLVANIA

727	FORWARD CALORIMETER #727 BEAM: Collision Area (D-0) SPLIT-FIELD MAGNET SPECTROMETER AND ELECTROMAGNETIC SHOWER DETECTOR FOR D-0. +-----+ Request 2 Nov, 82 Unspecified Withdrawn 16 May, 83	Jerome L. Rosen	NORTHWESTERN UNIVERSITY
728	MUON PRODUCTION #728 BEAM: Collision Area (D-0) STUDY OF MUONS FROM PBAR-P COLLISIONS UP TO SQUARE ROOT OF S EQUAL TO 2 TEV. (This proposal supercedes proposal #712.) +-----+ Request 1 Nov, 82 Unspecified Rejected 1 Jul, 83	Daniel R. Green	UNIVERSITY OF ARIZONA FERMILAB FLORIDA STATE UNIVERSITY UNIVERSITY OF MARYLAND VIRGINIA TECH
729	EMULSION/PROTONS @ 1 TEV #729 BEAM: Meson Area - Test Beam PROPOSAL TO STUDY CHARM AND MULTIPARTICLE PRODUCTION IN 1 TEV PROTON-EMULSION COLLISIONS +-----+ Request 24 Nov, 82 Unspecified Approval 5 Dec, 83 Emulsion Exposure Completed 26 Apr, 85 2 Emulsion Stack(s)	Atul Gurtu	TATA INSTITUTE (INDIA)
730	EMULSION/SIGMA-MINUS @ 250 #730 BEAM: Proton Area - Center EMULSION EXPOSURE TO 250 GEV SIGMA-MINUS. +-----+ Request 5 Jan, 83 Unspecified Approval 10 Feb, 84 Unspecified Completed 10 Feb, 84 4 Hours	Richard J. Wilkes	INP, KRAKOW (POLAND) INST. FOR NUCL. RESEARCH (BULGARIA) UNIVERSITY OF WASHINGTON
731	CP VIOLATION #731 BEAM: Meson Area - Center A MEASUREMENT OF THE MAGNITUDE OF $\langle E'/E \rangle$ IN THE NEUTRAL KAON SYSTEM TO A PRECISION OF .001. +-----+ Request 1 Feb, 83 Unspecified Approval 1 Jul, 83 Unspecified Completed 15 Feb, 88 3,100 Hours	Bruce D. Winstein	CEN-SACLAY (FRANCE) UNIVERSITY OF CHICAGO ELMHURST COLLEGE FERMILAB PRINCETON UNIVERSITY
732	XI-ZERO DECAY #732 BEAM: Proton Area - Center A SEARCH FOR THE DECAY NEUTRAL CASCADE TO PROTON AND NEGATIVE PION. +-----+ Request 1 Feb, 83 Unspecified Rejected 25 Jun, 85	Marleigh C. Sheaff	UNIVERSITY OF MICHIGAN - ANN ARBOR UNIVERSITY OF MINNESOTA RUTGERS UNIVERSITY UNIVERSITY OF WISCONSIN - MADISON
733	NEUTRINO INTERACTIONS #733 BEAM: Neutrino Area - Center PROPOSAL TO STUDY HIGH ENERGY NEUTRINO INTERACTIONS WITH THE TEVATRON QUADRUPOLE TRIPLET BEAM. +-----+ Request 1 Feb, 83 Unspecified 16 Sep, 83 Unspecified Approval 12 Nov, 83 Unspecified Stage I approval. Completed 1 Feb, 88 4,100 Hours	Raymond L. (Chip) Brock	FERMILAB UNIVERSITY OF FLORIDA MASSACHUSETTS INST. OF TECHNOLOGY MICHIGAN STATE UNIVERSITY
734	HYPERON PRODUCTION #734 BEAM: Proton Area - Center PRIMAKOFF PRODUCTION OF HYPERON EXCITED STATES. +-----+ Request 1 Apr, 83 Unspecified Inactive 21 May, 86	Michael V. Hynes	UNIV. OF CALIFORNIA, LOS ANGELES LOS ALAMOS NATIONAL LABORATORY
735	PARTICLE SEARCH #735 BEAM: Collision Area (C-0) SEARCH FOR A DECONFINED QUARK GLUON PHASE OF STRONGLY INTERACTING MATTER IN PBAR-P INTERACTIONS AT SQUARE ROOT OF S EQUAL TO 2 TEV. +-----+ Request 11 Apr, 83 Unspecified 16 Sep, 83 Unspecified Approval 15 Dec, 83 Unspecified Stage I approval. Completed 31 May, 89 Unspecified	Laszlo J. Gutay	DUKE UNIVERSITY FERMILAB IOWA STATE UNIVERSITY NOTRE DAME UNIVERSITY PURDUE UNIVERSITY UNIVERSITY OF WISCONSIN - MADISON
736	D-0 QUARK SEARCH #736 BEAM: Collision Area (D-0) A PROPOSAL TO CONDUCT A QUARK SEARCH AT THE FERMILAB COLLIDER. +-----+ Request 11 Apr, 83 Unspecified Rejected 1 Jul, 83	Robert K. Adair	BROOKHAVEN NATIONAL LABORATORY YALE UNIVERSITY
737	BATISS EXPERIMENT #737 BEAM: Unspecified Beam STUDY OF HIGH ENERGY NEUTRINOS WITH A DEEP UNDERWATER DETECTOR OF A MASS GREATER THAN 10 TO THE 6TH TONS. +-----+ Request 25 Apr, 83 Unspecified Rejected 12 Nov, 83	Peter Kotzer	KAZAKH STATE UNIV., (KAZAKHSTAN) MOSCOW STATE UNIVERSITY (RUSSIA) UNIVERSITY OF WASHINGTON WESTERN WASHINGTON UNIVERSITY
738	NARROW BAND #738 BEAM: Neutrino Area - Center LETTER OF INTENT TO RUN IN THE NARROW BAND AND BEAM AT TEVATRON II. +-----+ Request 3 Jun, 83 Unspecified Withdrawn 26 Apr, 84	Charles Baltay	COLUMBIA UNIVERSITY

739	ELECTRON-POSITRON #739 BEAM: Proton Area - East MEASUREMENTS OF CRYSTAL-ASSISTED ELECTRON-POSITRON PAIR CREATION. +-----+ Request 9 Sep, 83 Unspecified Rejected 19 Apr, 85	Nelson Cue and Chih-Ree Sun	UNIV. OF CLAUDE BERNARD (FRANCE) FERMILAB LAPP, D'ANNECY-LE-VIEUX (FRANCE) SUNY AT ALBANY
740	D-0 DETECTOR #740 BEAM: Collision Area (D-0) STUDY OF PROTON ANTI-PROTON COLLISIONS USING A LARGE DETECTOR AT D-0. +-----+ Request 9 Sep, 83 Unspecified Approval 10 Feb, 84 Unspecified Data Analysis 20 Feb, 96 Completed 1 Mar, 05	Paul D. Grannis and Hugh Elliott Montgomery	UNIVERSIDAD DE LOS ANDES (COLOMBIA) UNIVERSITY OF ARIZONA BOSTON UNIVERSITY BROOKHAVEN NATIONAL LABORATORY BROWN UNIVERSITY UNIVERSIDAD DE BUENOS AIRES UNIV. OF CALIFORNIA, DAVIS UNIV. OF CALIFORNIA, IRVINE UNIV. OF CALIFORNIA, RIVERSIDE CBPF (BRAZIL) CEN-SACLAY (FRANCE) CINVESTAV-IPN (MEXICO) COLUMBIA UNIVERSITY DELHI UNIVERSITY (INDIA) FERMILAB FLORIDA STATE UNIVERSITY UNIVERSITY OF HAWAII AT MANOA UNIV. OF ILLINOIS, CHICAGO CIRCLE INDIANA UNIVERSITY IOWA STATE UNIVERSITY JINR, DUBNA (RUSSIA) KOREA UNIVERSITY, SEOUL (KOREA) INP, KRAKOW (POLAND) KYUNGSUNG UNIVERSITY, PUSAN (KOREA) LAWRENCE BERKELEY LABORATORY UNIVERSITY OF MARYLAND UNIVERSITY OF MICHIGAN - ANN ARBOR MICHIGAN STATE UNIVERSITY MOSCOW STATE UNIVERSITY (RUSSIA) UNIVERSITY OF NEBRASKA SUNY AT STONY BROOK NEW YORK UNIVERSITY NORTHEASTERN UNIVERSITY NORTHERN ILLINOIS UNIVERSITY NORTHWESTERN UNIVERSITY NOTRE DAME UNIVERSITY UNIVERSITY OF OKLAHOMA PANJAB UNIVERSITY (INDIA) PNPI, ST. PETERSBURG (RUSSIA) IHEP, PROTIVNO (SERPUKHOV) (RUSSIA) PURDUE UNIVERSITY RICE UNIVERSITY UNIV. FEDERAL DO RIO DE JANEIRO UNIVERSITY OF ROCHESTER SEOUL NATIONAL UNIVERSITY (KOREA) SSC LABORATORY TATA INSTITUTE (INDIA) TEXAS A&M UNIVERSITY UNIVERSITY OF TEXAS AT ARLINGTON
741	COLLIDER DETECTOR #741 BEAM: Collision Area (B-0) STUDY OF PROTON ANTI-PROTON COLLISIONS USING A LARGE DETECTOR AT B-0. +-----+ Request 1 Apr, 82 Unspecified Approval 1 Apr, 82 Unspecified Completed 31 May, 89 Unspecified	Melvyn Jay Shochet and Alvin V. Tollestrup	ARGONNE NATIONAL LABORATORY BRANDEIS UNIVERSITY UNIVERSITY OF CHICAGO FERMILAB INFN, FRASCATI (ITALY) HARVARD UNIVERSITY UNIVERSITY OF ILLINOIS, CHAMPAIGN KEK (JAPAN) LAWRENCE BERKELEY LABORATORY UNIVERSITY OF PENNSYLVANIA INFN, PISA (ITALY) PURDUE UNIVERSITY ROCKEFELLER UNIVERSITY RUTGERS UNIVERSITY TEXAS A&M UNIVERSITY UNIVERSITY OF TSUKUBA (JAPAN) UNIVERSITY OF WISCONSIN - MADISON
742	STRANGE QUARK #742 BEAM: Proton Area - Center LETTER OF INTENT TO MEASURE OMEGA MINUS POLARIZATION AND MAGNETIC MOMENT. +-----+ Request 13 Jun, 83 Unspecified Inactive 15 Jun, 85	Joseph Lach	UNIVERSITY OF CHICAGO ELMHURST COLLEGE FERMILAB IOWA STATE UNIVERSITY UNIVERSITY OF IOWA PNPI, ST. PETERSBURG (RUSSIA) YALE UNIVERSITY
743	CHARM PRODUCTION #743 BEAM: Meson Area - Test Beam PROPOSAL TO MEASURE OPEN CHARM PRODUCTION IN PROTON-PROTON COLLISIONS AT 1 TEV WITH LEBC-FMPS. +-----+ Request 16 Sep, 83 Unspecified Approval 16 Dec, 83 Unspecified Stage I approval Completed 29 Aug, 85 1,256 K Pix	Stephen Reucroft	ITP, AACHEN (GERMANY) CERN (SWITZERLAND) CRN, STRASBOURG (FRANCE) DUKE UNIVERSITY FERMILAB FLORIDA STATE UNIVERSITY IHEP, BERLIN-ZEUTHEN (GERMANY) UNIVERSITY OF KANSAS UNIVERSITY OF L'ETAT (BELGIUM) UNIVERSITY OF LIBRE (BELGIUM) LPNHE, UN. OF P & M CURIE (FRANCE) UNIVERSITY OF MICHIGAN - ANN ARBOR MICHIGAN STATE UNIVERSITY NORTHEASTERN UNIVERSITY NOTRE DAME UNIVERSITY TATA INSTITUTE (INDIA) VANDERBILT UNIVERSITY VIENNA INSTITUTE FOR HEP (AUSTRIA)

744	CHARGED INTERACTIONS #744 BEAM: Neutrino Area - Center HIGH STATISTICS STUDIES OF CHARGED CURRENT INTERACTIONS USING THE TEVATRON QUAD TRIPLET BEAM.	Frank S. Merritt	UNIVERSITY OF CHICAGO COLUMBIA UNIVERSITY FERMILAB UNIVERSITY OF ROCHESTER
	Request 16 Sep, 83 Unspecified Approval 17 Nov, 83 Unspecified Stage I approval. Completed 29 Aug, 85 1,900 Hours		
745	MUON NEUTRINO #745 BEAM: Neutrino Area - Center MUON NEUTRINO EXPERIMENT USING THE TOHOKU HIGH RESOLUTION ONE METER BUBBLE CHAMBER.	Toshio Kitagaki	IHEP, BEIJING (PRC) BROWN UNIVERSITY FERMILAB INDIANA UNIVERSITY MASSACHUSETTS INST. OF TECHNOLOGY NAGOYA UNIVERSITY (JAPAN) OAK RIDGE NATIONAL LABORATORY UNIVERSITY OF TENNESSEE, KNOXVILLE TOHOKU GAKUIN UNIVERSITY (JAPAN) TOHOKU UNIVERSITY (JAPAN)
	Request 10 Sep, 83 Unspecified Approval 16 Dec, 83 Parasitic Running Completed 1 Feb, 88 553 K Pix		
746	PROMPT BEAM FACILITY #746 BEAM: Unspecified Beam LETTER OF INTENT TO SEARCH FOR NEW PARTICLES FROM THE PROMPT BEAM FACILITY.	James K. Walker	FERMILAB MASSACHUSETTS INST. OF TECHNOLOGY MICHIGAN STATE UNIVERSITY
	Request 1 Sep, 83 Unspecified Withdrawn 2 Jun, 86		
747	CHARGED PARTICLES #747 BEAM: Proton Area - Broad Band A SEARCH FOR FRACTIONALLY CHARGED PARTICLES AT THE TEVATRON.	Alan A. Hahn	CALIFORNIA INSTITUTE OF TECHNOLOGY UNIV. OF CALIFORNIA, IRVINE FERMILAB LAWRENCE BERKELEY LABORATORY LAWRENCE LIVERMORE LABORATORY LOS ALAMOS NATIONAL LABORATORY UNIVERSITY OF ROCHESTER SAN FRANCISCO STATE UNIVERSITY UNIVERSITY OF TORONTO (CANADA)
	Request 27 Feb, 84 Unspecified Approval 1 Apr, 85 Unspecified Completed 2 Aug, 85 Unspecified		
748	BEAUTY & CHARM PRODUCTION #748 BEAM: Unspecified Beam LETTER OF INTENT TO STUDY BEAUTY AND CHARM AT THE TEVATRON USING HIGH RESOLUTION STEAMER CHAMBER AND A DOWNSTREAM SPECTROMETER.	Jack Sandweiss	FERMILAB NEW YORK UNIVERSITY UNIVERSITY OF VRIJE (BELGIUM) YALE UNIVERSITY
	Request 7 May, 84 Unspecified Withdrawn 2 Oct, 84		
749	CHANNELING #749 BEAM: Meson Area - Bottom LETTER OF INTENT TO STUDY MATERIAL AND FABRICATION ASPECTS OF CRYSTALS USED FOR CHANNELING.	James S. Forster	CHALK RIVER NUCLEAR LAB. (CANADA) FERMILAB UNIVERSITY OF NEW MEXICO SUNY AT ALBANY
	Request 19 Jul, 84 400 Hours Withdrawn 1 Oct, 84		
750	MULTIPARTICLE PRODUCTION #750 BEAM: Neutrino Area - Miscellaneous A PROPOSAL TO STUDY MULTIPARTICLE PRODUCTION IN INTERACTIONS OF 1 TEV PROTONS WITH EMULSION NUCLEI.	Ram K. Shivpuri	DELHI UNIVERSITY (INDIA)
	Request 27 Jun, 84 Emulsion Exposure beam at or near 1 TeV protons of flux approximately 5 x 10 to the 4th protons/sq cm over an area of (8 x 3)sq cm Approval 23 Jul, 84 Emulsion Exposure Completed 11 Jul, 85 1 Emulsion Stack(s)		
751	EMULSION EXPOSURE @ 1 TEV #751 BEAM: Meson Area - Test Beam PROPOSAL TO STUDY 1 TEV PROTON INTERACTIONS IN EMULSION.	Piyare L. Jain	SUNY AT BUFFALO
	Request 27 Jun, 84 Emulsion Exposure Approval 2 Jul, 84 Emulsion Exposure Completed 26 Apr, 85 1 Emulsion Stack(s)		
752	PARTICLE COLLISIONS #752 BEAM: Unspecified Beam PROPOSAL TO SEARCH FOR ANOMALOUSLY LARGE HADRON CROSS SECTIONS AT SHORT DISTANCES.	James W. Cronin	UNIVERSITY OF CHICAGO TECHNION-ISRAEL INST (ISRAEL)
	Request 23 Oct, 84 200 Hours Withdrawn 8 Dec, 86		
753	CHANNELING STUDIES #753 BEAM: Meson Area - Bottom PROPOSAL TO IMPROVE THE DEFLECTION OF HIGH ENERGY PARTICLE BEAMS BY CHANNELING IN BENT CRYSTALS OF SI AND GE.	James S. Forster	BELL NORTHERN RESEARCH LAB(CANADA) CHALK RIVER NUCLEAR LAB. (CANADA) FERMILAB UNIVERSITY OF NEW MEXICO SUNY AT ALBANY
	Request 28 Sep, 84 400 Hours Approval 20 Nov, 84 Unspecified Completed 5 Jul, 85 150 Hours		
754	CHANNELING TESTS #754 BEAM: Meson Area - Bottom CRYSTAL CHANNELING TESTS IN M-BOTTOM INCLUDING FOCUSING WITH DEFORMED CRYSTALS AND STUDIES OF HIGH Z CRYSTALS.	Chih-Ree Sun	FERMILAB GENERAL ELECTRIC R&D CENTER SUNY AT ALBANY SANDIA LABORATORIES SSC LABORATORY
	Request 1 Oct, 84 300 Hours Approval 20 Nov, 84 Unspecified Approved/Inactive 24 Dec, 91		

755	BEAUTY & CHARM STUDY #T755 BEAM: Meson Area - Test Beam A HIGH SENSITIVITY STUDY OF BEAUTY AND CHARM IN HADROPRODUCTION AT THE TEVATRON.	Richard D. Majka and Anna Jean Slaughter	FERMILAB YALE UNIVERSITY
	+-----+ Request 2 Oct, 84 Unspecified Approval 25 Nov, 86 Unspecified Completed 15 Feb, 88 Unspecified		
756	MAGNETIC MOMENT #756 BEAM: Proton Area - Center MEASUREMENT OF THE MAGNETIC MOMENT OF THE OMEGA MINUS HYPERON.	Kam-Biu Luk	UNIVERSITY OF ARIZONA UNIV. OF CALIFORNIA, BERKELEY FERMILAB INDIANA UNIVERSITY LAWRENCE BERKELEY LABORATORY UNIVERSITY OF MICHIGAN - ANN ARBOR UNIVERSITY OF MINNESOTA RUTGERS UNIVERSITY
	+-----+ Request 8 Oct, 84 1,000 Hours Approval 25 Jun, 85 1,000 Hours Stage I approval Completed 15 Feb, 88 1,700 Hours		
757	MUON DEFLECTION #757 BEAM: Neutrino Area - Muon Beam LETTER OF INTENT FOR A PROPOSAL TO STUDY MOMENTUM RESOLUTION FOR MUONS ABOVE 300 GEV IN MAGNETIZED IRON.	Jorge G. Morfin	FERMILAB UNIVERSITY OF ILLINOIS, CHAMPAIGN UNIVERSITY OF WASHINGTON UNIVERSITY OF WISCONSIN - MADISON
	+-----+ Request 12 Dec, 84 Test Running Rejected 14 Dec, 85		
758	EMULSION EXPOSURE #758 BEAM: Meson Area - Test Beam STUDY OF THE MECHANISM OF MULTIPARTICLE PRODUCTION IN EMULSION NUCLEI @ 800 GEV PROTONS.	Mitsuko Kazuno and Hiroshi Shibuya	NAGOYA UNIVERSITY (JAPAN) TOHO UNIVERSITY (JAPAN)
	+-----+ Request 11 Mar, 85 Unspecified Approval 11 Mar, 85 Unspecified Completed 26 Apr, 85 2 Emulsion Stack(s)		
759	EMULSION EXPOSURE #759 BEAM: Meson Area - Test Beam A STUDY OF NUCLEAR INTERACTIONS OF 800 GEV PROTONS IN EMULSION.	Yoshihiro Tsuzuki	KOBE UNIVERSITY (JAPAN) OSAKA CITY UNIVERSITY (JAPAN) OSAKA SCIENCE EDUC. INST. (JAPAN)
	+-----+ Request 11 Mar, 85 Unspecified Approval 11 Mar, 85 Unspecified Completed 26 Apr, 85 2 Emulsion Stack(s)		
760	CHARMONIUM STATES #760 BEAM: Accumulator Ring A PROPOSAL TO INVESTIGATE THE FORMATION OF CHARMONIUM STATES USING THE PBAR ACCUMULATOR RING.	Rosanna Cester	UNIV. OF CALIFORNIA, IRVINE FERMILAB UNIVERSITY OF FERRARA (ITALY) INFN, GENOVA (ITALY) NORTHWESTERN UNIVERSITY PENNSYLVANIA STATE UNIVERSITY UNIVERSITY OF TORINO (ITALY)
	+-----+ Request 29 Mar, 85 Unspecified Approval 25 Jun, 85 Unspecified Data Analysis 10 Jan, 92 Unspecified Completed 1 Mar, 99 Unspecified		
761	HYPERON RADIATIVE DECAY #761 BEAM: Proton Area - Center PROPOSAL TO STUDY HYPERON RADIATIVE DECAY.	Alexei A. Vorobiev	IHEP, BEIJING (PRC) UNIVERSITY OF BRISTOL (ENGLAND) CBPF (BRAZIL) FERMILAB UNIVERSITY OF IOWA ITEP, MOSCOW (RUSSIA) PNPI, ST. PETERSBURG (RUSSIA) UNIV. FEDERAL DO RIO DE JANEIRO UNIVERSITE OF SAO PAULO (BRAZIL) YALE UNIVERSITY
	+-----+ Request 3 Apr, 85 Unspecified Approval 25 Jun, 85 Unspecified Stage I approval Completed 27 Aug, 90 Unspecified		
762	EMULSION/PROTONS @ 800 GEV #762 BEAM: Meson Area - Test Beam CASCADE SHOWERS ORIGINATING IN PROTON-NUCLEUS COLLISIONS.	Shoji Dake	AOYAMA GAKUIN UNIVERSITY (JAPAN) ICRR, UNIVERSITY OF TOKYO (JAPAN) KOBE UNIVERSITY (JAPAN) OKAYAMA UNIVERSITY (JAPAN) OSAKA SCIENCE EDUC. INST. (JAPAN)
	+-----+ Request 11 Jun, 85 Unspecified Approval 21 Jun, 85 Unspecified Completed 11 Jul, 85 18 Emulsion Stack(s)		
763	EMULSION/PROTONS @ 800 GEV #763 BEAM: Meson Area - Test Beam PROTON-NUCLEUS INTERACTIONS AT TEVATRON ENERGY.	Takeshi Ogata	ICRR, UNIVERSITY OF TOKYO (JAPAN) KOBE UNIVERSITY (JAPAN) OKAYAMA UNIVERSITY (JAPAN) OSAKA SCIENCE EDUC. INST. (JAPAN)
	+-----+ Request 11 Jun, 85 Unspecified Approval 21 Jun, 85 Unspecified Completed 11 Jul, 85 2 Emulsion Stack(s)		
764	EMULSION EXPOSURE #764 BEAM: Meson Area - Test Beam EXCLUSIVE INVESTIGATION OF MULTIPLE PRODUCTION IN RAPIDITY SPACE.	Hirotsada Nanjo	HIROSAKI UNIVERSITY (JAPAN)
	+-----+ Request 11 Jun, 85 Unspecified Approval 21 Jun, 85 Unspecified Completed 11 Jul, 85 1 Emulsion Stack(s)		
765	EMULSION/PROTONS @ 800 GEV #765 BEAM: Meson Area - Test Beam TRANSVERSE MOMENTUM MEASUREMENT OF SECONDARY PARTICLES IN PROTON-EMULSION COLLISIONS AT 800 GEV.	K. Imaeda	OKAYAMA UNIVERSITY (JAPAN)
	+-----+ Request 20 Jun, 85 Unspecified Approval 21 Jun, 85 Unspecified Completed 11 Jul, 85 7 Emulsion Stack(s)		

766	MR TUNNEL NEUTRONS #T766 BEAM: Collision Area (Miscellaneous) MEASUREMENTS OF THE NEUTRON SPECTRUM IN THE TEVATRON TUNNEL WITH APPLICATION TO THE SSC.	Joseph B. McCaslin	FERMILAB LAWRENCE BERKELEY LABORATORY
	Request	11 Jul, 85	Unspecified
	Approval	17 Jul, 85	Unspecified
	Completed	13 Oct, 85	Unspecified
767	MUON CALORIMETRY #767 BEAM: Neutrino Area - Muon Beam MEASUREMENT OF DIRECT ELECTRON PAIR PRODUCTION CROSS-SECTION IN THE TEVATRON MUON BEAM.	Yasushi Muraki	CHUO UNIVERSITY (JAPAN) ICRR, UNIVERSITY OF TOKYO (JAPAN) KEK (JAPAN) NAGOYA UNIVERSITY (JAPAN)
	Request	29 Aug, 85	Unspecified
	Rejected	1 Jul, 86	
768	POLARIZED SCATTERING #768 BEAM: Proton Area - West PROTON - PROTON ELASTIC SCATTERING WITH A POLARIZED TARGET.	Alan D. Krisch	BROOKHAVEN NATIONAL LABORATORY CERN (SWITZERLAND) FERMILAB LHE, ETH HONGGERBERG (SWITZERLAND) UNIVERSITY OF MARYLAND MASSACHUSETTS INST. OF TECHNOLOGY UNIVERSITY OF MICHIGAN - ANN ARBOR NOTRE DAME UNIVERSITY TEXAS A&M UNIVERSITY
	Request	12 Nov, 85	Unspecified
	Rejected	30 Jun, 87	
769	PION & KAON CHARM PROD. #769 BEAM: Proton Area - East PION AND KAON PRODUCTION OF CHARM AND CHARM-STRANGE STATE.	Jeffrey A. Appel	CBPF (BRAZIL) FERMILAB UNIVERSITY OF MISSISSIPPI NORTHEASTERN UNIVERSITY UNIVERSITY OF TORONTO (CANADA) TUFTS UNIVERSITY UNIVERSITY OF WISCONSIN - MADISON YALE UNIVERSITY
	Request	14 Dec, 85	Unspecified
	Approval	14 Dec, 85	Unspecified
	Data Analysis	15 Feb, 88	1,900 Hours
	Completed	1 Mar, 99	Unspecified
770	QUAD TRIPLET NEUTRINO #770 BEAM: Neutrino Area - Center HIGH STATISTICS STUDIES OF CHARGED CURRENT INTERACTIONS USING THE TEVATRON QUAD TRIPLET BEAM.	Wesley H. Smith	UNIVERSITY OF CHICAGO COLUMBIA UNIVERSITY FERMILAB UNIVERSITY OF ROCHESTER UNIVERSITY OF WISCONSIN - MADISON
	Request	27 Dec, 85	Unspecified
	Approval	27 Dec, 85	Unspecified Stage I approval.
	Completed	1 Feb, 88	1,600 Hours
771	BEAUTY PRODUCTION BY PROTONS #771 BEAM: Proton Area - West PROPOSAL TO STUDY BEAUTY PRODUCTION AND OTHER HEAVY QUARK PHYSICS ASSOCIATED WITH DIMUON PRODUCTION IN 800 (925) GEV/C PP INTERACTIONS.	Bradley B. Cox	UNIVERSITY OF SOUTH ALABAMA UNIVERSITY OF ATHENS (GREECE) BROWN UNIVERSITY UNIV. OF CALIFORNIA, BERKELEY UNIV. OF CALIFORNIA, LOS ANGELES DUKE UNIVERSITY FERMILAB UNIVERSITY OF HOUSTON JINR, DUBNA (RUSSIA) UNIVERSITY OF LECCE (ITALY) MASSACHUSETTS INST. OF TECHNOLOGY MCGILL UNIVERSITY (CANADA) NANJING UNIVERSITY (PRC) NORTHWESTERN UNIVERSITY UNIVERSITY OF PAVIA (ITALY) UNIVERSITY OF PENNSYLVANIA PRAIRIE VIEW A&M UNIVERSITY SHANDONG UNIVERSITY (PRC) VANIER COLLEGE (CANADA) UNIVERSITY OF VIRGINIA UNIVERSITY OF WISCONSIN - MADISON
	Request	10 Dec, 86	Unspecified
	Approval	4 Apr, 87	Unspecified
	Data Analysis	8 Jan, 92	Unspecified
	Completed	1 Mar, 99	Unspecified
772	DIMUONS #772 BEAM: Meson Area - East STUDY OF THE NUCLEAR ANTIQUARK SEA VIA P+N -> DIMUONS.	Joel M. Moss	CASE WESTERN RESERVE UNIVERSITY FERMILAB UNIV. OF ILLINOIS, CHICAGO CIRCLE LOS ALAMOS NATIONAL LABORATORY SUNY AT STONY BROOK NORTHERN ILLINOIS UNIVERSITY RUTGERS UNIVERSITY UNIVERSITY OF SOUTH CAROLINA UNIVERSITY OF TEXAS AT AUSTIN UNIVERSITY OF WASHINGTON
	Request	11 Mar, 86	Unspecified
	Approval	1 Jul, 86	Unspecified
	Completed	15 Feb, 88	1,700 Hours
773	ETA00 & ETA+- PHASE DIFFERENCE #773 BEAM: Meson Area - Center MEASUREMENT OF PHASE DIFFERENCE BETWEEN ETA 00 AND ETA +- TO A PRECISION OF 1/2 DEGREE.	George D. Gollin	UNIVERSITY OF CHICAGO ELMHURST COLLEGE FERMILAB UNIVERSITY OF ILLINOIS, CHAMPAIGN RUTGERS UNIVERSITY
	Request	11 Mar, 86	Unspecified
	Approval	1 Jul, 86	Unspecified
		29 Jun, 89	Unspecified Stage II approval.
	Completed	30 Sep, 91	Unspecified
774	ELECTRON BEAM DUMP #774 BEAM: Proton Area - Broad Band ELECTRON BEAM DUMP PARTICLE SEARCH IN THE WIDE BAND HALL.	Michael B. Crisler	FERMILAB UNIVERSITY OF ILLINOIS, CHAMPAIGN INF, KRAKOW (POLAND) NORTHEASTERN UNIVERSITY
	Request	4 Apr, 86	Unspecified
	Approval	10 Dec, 86	Unspecified
	Completed	27 Aug, 90	Unspecified

775	CDF UPGRADE #775 BEAM: Collision Area (B-0) CDF UPGRADE (Level-3 Trigger; Silicon Vertex (#775A); and Muon System (#775B)) +-----+ Request 28 May, 86 Unspecified Approval 1 Jul, 86 Unspecified Phase I approval Data Analysis 20 Feb, 96 Completed 1 Mar, 05	William C. Carithers, Jr. and Giorgio Bellezzini	IHEP, ACADEMIA SINICA (TAIWAN) ARGONNE NATIONAL LABORATORY UNIVERSITY OF BOLOGNA (ITALY) BRANDEIS UNIVERSITY UNIV. OF CALIFORNIA, LOS ANGELES CIPP (CANADA) UNIVERSITY OF CHICAGO DUKE UNIVERSITY FERMILAB INFN, FRASCATI (ITALY) HARVARD UNIVERSITY HIROSHIMA UNIVERSITY (JAPAN) UNIVERSITY OF ILLINOIS, CHAMPAIGN JOHNS HOPKINS UNIVERSITY KEK (JAPAN) LAWRENCE BERKELEY LABORATORY MASSACHUSETTS INST. OF TECHNOLOGY UNIVERSITY OF MICHIGAN - ANN ARBOR MICHIGAN STATE UNIVERSITY UNIVERSITY OF NEW MEXICO OSAKA CITY UNIVERSITY (JAPAN) UNIVERSITY OF PADOVA (ITALY) UNIVERSITY OF PENNSYLVANIA INFN, PISA (ITALY) UNIVERSITY OF PITTSBURGH PURDUE UNIVERSITY UNIVERSITY OF ROCHESTER ROCKEFELLER UNIVERSITY RUTGERS UNIVERSITY TEXAS A&M UNIVERSITY TEXAS TECH UNIVERSITY UNIVERSITY OF TSUKUBA (JAPAN) TUFTS UNIVERSITY WASEDA UNIVERSITY (JAPAN) UNIVERSITY OF WISCONSIN - MADISON YALE UNIVERSITY
776	NUCLEAR CAL. CROSS SECTIONS#776 BEAM: Miscellaneous Area MEASUREMENT OF NUCLEAR CALIBRATION CROSS SECTIONS FOR PROTONS GREATER THAN 400 GEV. +-----+ Request 6 Aug, 86 Unspecified Approval 7 Jan, 87 Unspecified Completed 15 Feb, 88 Unspecified	Samuel I. Baker	BROOKHAVEN NATIONAL LABORATORY CERN (SWITZERLAND) FERMILAB
777	MR TUNNEL NEUTRONS #777 BEAM: Collision Area (Miscellaneous) NEUTRON FLUX MEASUREMENTS IN THE TEVATRON TUNNEL. +-----+ Request 29 Oct, 86 Unspecified Approval 7 Jan, 87 Unspecified Completed 11 May, 87 Unspecified	Joseph B. McCaslin	FERMILAB LAWRENCE BERKELEY LABORATORY SSC CENTRAL DESIGN GROUP
778	MAGNET APERTURE STUDIES #778 BEAM: Collision Area (Miscellaneous) STUDY OF THE SSC MAGNET APERTURE CRITERION. +-----+ Request 18 Oct, 86 Unspecified Approval 10 Dec, 86 Unspecified Completed 21 Jan, 91 Unspecified	Rodney E. Gerig and Richard Talman	CERN (SWITZERLAND) CORNELL UNIVERSITY FERMILAB UNIVERSITY OF HOUSTON SSC CENTRAL DESIGN GROUP SLAC
779	HIGH RATE CALORIMETER STUDY#779 BEAM: Meson Area - West PROPOSAL TO BUILD A VERY HIGH RATE CALORIMETER. +-----+ Request 29 Oct, 86 Unspecified Rejected 10 Dec, 86	David F. Anderson	FERMILAB
780	CHARM PRODUCTION BY PROTONS#780 BEAM: Neutrino Area - East STUDY OF CHARM PRODUCED BY 850 GEV PROTONS. +-----+ Request 1 Mar, 87 Unspecified Rejected 14 Dec, 87	Ronald J. Lipton and Douglas M. Potter	UNIV. OF CALIFORNIA, DAVIS CARNEGIE-MELLON UNIVERSITY UNIVERSITY OF OKLAHOMA
781	LARGE-X BARYON SPECTROMETER#781 BEAM: Proton Area - Center SEGMENTED LARGE-X BARYON SPECTROMETER (SELEX). +-----+ Request 4 Mar, 87 Unspecified Approval 24 Oct, 88 Unspecified In Progress 20 Feb, 97 Data Analysis 3 Sep, 97	James S. Russ	IHEP, BEIJING (PRC) BOGAZICI UNIVERSITY (TURKEY) UNIVERSITY OF BRISTOL (ENGLAND) CARNEGIE-MELLON UNIVERSITY CBPF (BRAZIL) FERMILAB UNIVERSITY OF HAWAII AT MANOA UNIVERSITY OF IOWA MAX-PLANCK INSTITUTE (GERMANY) MOSCOW STATE UNIVERSITY (RUSSIA) ITEP, MOSCOW (RUSSIA) UNIV. FEDERAL DO PARAIBA (BRAZIL) PNPI, ST. PETERSBURG (RUSSIA) IHEP, PROTIVNO (SERPUKHOV) (RUSSIA) UNIVERSITY OF ROCHESTER INFN, ROME (ITALY) UN.AUTO.DE SAN LUIS POTOSI (MEXICO) UNIVERSITE OF SAO PAULO (BRAZIL) UNIVERSITY OF TEL-AVIV (ISRAEL) INFN, TRIESTE (ITALY)

782	MUONS IN 1M BUBBLE CHAMBER #782 BEAM: Neutrino Area - NK Beam A MUON EXPOSURE IN THE TOHOKU HIGH RESOLUTION BUBBLE CHAMBER.	Toshio Kitagaki	HEP, BEIJING (PRC) BROWN UNIVERSITY FERMILAB MASSACHUSETTS INST. OF TECHNOLOGY OAK RIDGE NATIONAL LABORATORY SENSYU UNIVERSITY (JAPAN) SUGIYAMA JOGAKUEN UNIV. (JAPAN) UNIVERSITY OF TENNESSEE, KNOXVILLE TOHOKU GAKUIN UNIVERSITY (JAPAN) TOHOKU UNIVERSITY (JAPAN)
	Request	4 Feb, 87	Unspecified
	Approval	16 Jul, 87	Unspecified
	Completed	21 Jul, 90	330 K Pix
783	TEVATRON BEAUTY FACTORY #783 BEAM: Collision Area (C-0) LETTER OF INTENT FOR A TEVATRON COLLIDER BEAUTY FACTORY.	Neville W. Reay	UNIV. OF CALIFORNIA, DAVIS CARNEGIE-MELLON UNIVERSITY FERMILAB OHIO STATE UNIVERSITY UNIVERSITY OF OKLAHOMA
	Request	4 Mar, 87	Unspecified
	Inactive	23 Dec, 92	
784	BOTTOM AT THE COLLIDER #784 BEAM: Unspecified Beam PROPOSAL FOR RESEARCH & DEVELOPMENT: VERTEXING, TRACKING AND DATA ACQUISITION FOR THE BOTTOM COLLIDER DETECTOR.	Nigel S. Lockyer	UNIVERSIDAD DE LOS ANDES (COLOMBIA) UNIV. OF CALIFORNIA, DAVIS FERMILAB UNIVERSITY OF FLORIDA UNIVERSITY OF HOUSTON ILLINOIS INSTITUTE OF TECHNOLOGY UNIVERSITY OF IOWA NORTHEASTERN UNIVERSITY NORTHERN ILLINOIS UNIVERSITY OHIO STATE UNIVERSITY UNIVERSITY OF OKLAHOMA UNIVERSITY OF PENNSYLVANIA PRAIRIE VIEW A&M UNIVERSITY PRINCETON UNIVERSITY UNIV. OF PUERTO RICO - RIO PIEDRAS UN.SAN FRANCISCO DE QUITO (ECUADOR) YALE UNIVERSITY
	Request	2 Jan, 89	Unspecified
	Approval	30 Jan, 89	Unspecified
	Completed	8 Jan, 92	Unspecified
	Approval of Phase I (bench tests) and Phase II (beam tests). Phase III (C0 run at the Tevatron Collider) deferred pending results of simulation studies.		
785	LOW ENERGY ANTIMATTER #785 BEAM: Miscellaneous Area ANTIMATTER PHYSICS AT LOW ENERGY (AMPLE)	Billy Bonner and Lawrence Pinsky	UNIVERSITY OF HOUSTON RICE UNIVERSITY
	Request	12 Mar, 87	Unspecified
	Withdrawn	24 Oct, 88	
786	TEVATRON MUON #786 BEAM: Neutrino Area - Muon Beam WEAK INTERACTIONS AND HEAVY QUARK PHYSICS WITH THE TEVATRON MUON BEAM.	Richard Wilson	ARGONNE NATIONAL LABORATORY UNIV. OF CALIFORNIA, SAN DIEGO FERMILAB FREIBURG UNIVERSITY (GERMANY) HARVARD UNIVERSITY UNIV. OF ILLINOIS, CHICAGO CIRCLE INP, KRAKOW (POLAND) UNIVERSITY OF MARYLAND MASSACHUSETTS INST. OF TECHNOLOGY MAX-PLANCK INSTITUTE (GERMANY) UNIVERSITY OF WASHINGTON UNIVERSITY OF WUPPERTAL (GERMANY) YALE UNIVERSITY
	Request	10 May, 87	Unspecified
	Rejected	29 Jun, 88	
787	PARTICLE SEARCH #787 BEAM: Collision Area (C-0) PARTICLE SEARCH (PHASE II OF E-735).	Alfred T. Goshaw	DEPAW UNIVERSITY DUKE UNIVERSITY FERMILAB IOWA STATE UNIVERSITY NOTRE DAME UNIVERSITY PURDUE UNIVERSITY UNIVERSITY OF WISCONSIN - MADISON
	Request	30 Jun, 87	Unspecified
	Rejected	1 May, 89	
788	NEUTRINO OSCILLATIONS #788 BEAM: Neutrino Area - Center NEUTRINO OSCILLATIONS AND CROSS-SECTIONS IN A TAGGED NEUTRINO LINE.	Robert H. Bernstein	FERMILAB UNIV. OF PARIS VI, LPG (FRANCE)
	Request	11 Aug, 87	Unspecified
	Inactive	23 Dec, 92	
789	B-QUARK MESONS & BARYONS #789 BEAM: Meson Area - East MEASUREMENT OF THE PRODUCTION AND DECAY INTO TWO-BODY MODES OF B-QUARK MESONS AND BARYONS.	Daniel M. Kaplan and Jen-Chieh Peng	ABILENE CHRISTIAN UNIVERSITY IHEP, ACADEMIA SINICA (TAIWAN) UNIVERSITY OF CHICAGO FERMILAB LAWRENCE BERKELEY LABORATORY LOS ALAMOS NATIONAL LABORATORY NORTHERN ILLINOIS UNIVERSITY UNIVERSITY OF SOUTH CAROLINA
	Request	9 Nov, 87	Unspecified
	Approval	24 Oct, 88	Unspecified
	Data Analysis	8 Jan, 92	Unspecified
	Completed	1 Mar, 99	Unspecified
790	CALORIMETER FOR ZEUS #790 BEAM: Neutrino Area - Test Beam CALORIMETER MODULE CALIBRATION FOR ZEUS DETECTOR.	Frank J. Sciulli	ARGONNE NATIONAL LABORATORY COLUMBIA UNIVERSITY UNIVERSITY OF IOWA LOUISIANA STATE UNIVERSITY OHIO STATE UNIVERSITY PENNSYLVANIA STATE UNIVERSITY VIRGINIA TECH UNIVERSITY OF WISCONSIN - MADISON
	Request	5 Jun, 87	Unspecified
	Approval	17 Dec, 87	Unspecified
	Completed	27 Aug, 90	Unspecified

791	HADROPRODUCTION HEAVY FLAVORS #791 BEAM: Proton Area - East Search for the Flavor-Changing Neutral-Current Decays	Jeffrey A. Appel and Milind Vasant Purohit	UNIV. OF CALIFORNIA, SANTA CRUZ CBPF (BRAZIL) UNIVERSITY OF CINCINNATI CINVESTAV-IPN (MEXICO) FERMILAB ILLINOIS INSTITUTE OF TECHNOLOGY KANSAS STATE UNIVERSITY UNIVERSITY OF MISSISSIPPI OHIO STATE UNIVERSITY PRINCETON UNIVERSITY UN.AUTONOMA DE PUEBLA (MEXICO) UNIV. FEDERAL DO RIO DE JANEIRO UNIVERSITY OF SOUTH CAROLINA STANFORD UNIVERSITY UNIVERSITY OF TEL-AVIV (ISRAEL) TUFTS UNIVERSITY UNIVERSITY OF WISCONSIN - MADISON YALE UNIVERSITY
	Request 10 Nov, 87 Unspecified Approval 29 Jun, 88 Unspecified Data Analysis 8 Jan, 92 Unspecified Completed 1 Mar, 99 Unspecified		
792	NUCLEAR FRAGMENTS #792 BEAM: Meson Area - East STUDY OF FRAGMENTATION PRODUCTS FROM THE REACTION 800 GEV P + 197 AU.	Kjell Aleklett and Lembit Sihver	LAL, ORSAY (FRANCE) UPPSALA UNIVERSITY (SWEDEN)
	Request 15 Jan, 88 Unspecified Approval 15 Jan, 88 Unspecified Completed 15 Feb, 88 Unspecified		
793	EMULSION EXPOSURE 1000 GeV #793 BEAM: Proton Area - Miscellaneous Emulsion Exposure to 1000 GeV, or highest energy protons.	Jere J. Lord	KAZAKH STATE UNIV., (KAZAKHSTAN) WASHINGTON NATURAL PHILOSOPHY INS. UNIVERSITY OF WASHINGTON
	Request 19 Feb, 88 Unspecified Approval 21 Sep, 88 Unspecified Approved/Inactive 13 Jan, 94		
794	AXION HELIOSCOPE #794 BEAM: Unspecified Beam CONSTRUCTION AND OPERATION OF AN AXION HELIOSCOPE.	Karl Van Bibber	UNIV. OF CALIFORNIA, BERKELEY CERN (SWITZERLAND) LAWRENCE BERKELEY LABORATORY LAWRENCE LIVERMORE LABORATORY OHIO STATE UNIVERSITY TEXAS A&M UNIVERSITY TEXAS ACCELERATOR CENTER
	Request 5 Mar, 88 Unspecified Inactive 23 Dec, 92		
795	WARM LIQUID CALORIMETRY TEST #795 BEAM: Meson Area - Test Beam TEST OF ELECTRON/HADRON COMPENSATION FOR WARM LIQUID CALORIMETRY.	Morris Pripstein	UNIVERSITY OF ALABAMA UNIV. OF CALIFORNIA, BERKELEY CEN-SACLAY (FRANCE) CERN (SWITZERLAND) FERMILAB COLLEGE DE FRANCE (FRANCE) HARVARD UNIVERSITY KIYOTO UNIVERSITY (JAPAN) LAPP, D'ANNECY-LE-VIEUX (FRANCE) LAWRENCE BERKELEY LABORATORY
	Request 1 Mar, 88 Unspecified Approval 24 Oct, 88 Unspecified Completed 23 Dec, 91 Unspecified		
796	CP VIOLATION #796 BEAM: Proton Area - Center A MEASUREMENT OF THE CP VIOLATION PARAMETER $N=0$ THE SON OF E621.	Gordon B. Thomson	UNIVERSITY OF MINNESOTA RUTGERS UNIVERSITY
	Request 1 Jun, 88 Unspecified Withdrawn 4 Jan, 94		
797	FINE-GRAINED ELECTROMAG. CAL. #797 BEAM: Proton Area - East FINE-GRAINED ELECTROMAGNETIC CALORIMETRY.	H. Richard Gustafson and Rudolf P. Thun	UNIVERSITY OF MICHIGAN - ANN ARBOR
	Request 31 Aug, 88 Unspecified Approval 1 Apr, 90 Unspecified Completed 20 May, 90 Unspecified		
798	SSC DETECTOR TEST #798 BEAM: Proton Area - East PROPOSAL TO BUILD A SYNCHROTRON-RADIATION DETECTOR FOR TAGGING ELECTRONS AT THE SSC.	Priscilla Cushman and Roger W. Rusack	ROCKEFELLER UNIVERSITY YALE UNIVERSITY
	Request 20 Jul, 88 Unspecified Approval 30 Jan, 89 Unspecified Stage I approval. Completed 2 May, 90 Unspecified		
799	CP VIOLATION #799 BEAM: Neutrino Area - Muon Beam PROPOSAL TO SEARCH FOR RARE KAON DECAY.	Robert S. Tschirhart	UNIVERSITY OF ARIZONA UNIV. OF CALIFORNIA, LOS ANGELES UNIV. OF CALIFORNIA, SAN DIEGO UNIV. ESTADUAL DE CAMPINAS (BRAZIL) UNIVERSITY OF CHICAGO UNIVERSITY OF COLORADO AT BOULDER ELMHURST COLLEGE FERMILAB OSAKA UNIVERSITY (JAPAN) RICE UNIVERSITY RUTGERS UNIVERSITY UNIVERSITE DE SAO PAULO (BRAZIL) UNIVERSITY OF VIRGINIA UNIVERSITY OF WISCONSIN - MADISON
	Request 2 Jan, 89 Unspecified Approval 29 Jun, 89 Unspecified Stage I approval for phases 1 and 2 Jul, 91 Unspecified Stage II approval deferred In Progress 1 Oct, 91 Data Analysis 17 Jan, 00		
800	MAGNETIC MOMENT #800 BEAM: Proton Area - Center MEASUREMENT OF THE MAGNETIC MOMENT OF THE OMEGA MINUS HYPERON.	Kenneth A. Johns and Regina A. Rameika	UNIVERSITY OF ARIZONA DEPAUW UNIVERSITY FERMILAB UNIVERSITY OF MICHIGAN - ANN ARBOR UNIVERSITY OF MINNESOTA
	Request 1 Mar, 88 Unspecified Approval 5 Oct, 88 Unspecified Completed 8 Jan, 92 Unspecified		

801	PHOTON TOTAL XSECTION-URANIUM #801	G. L. Bayatian	YEREVAN PHYSICS INST. (ARMENIA)
	BEAM: Proton Area - Broad Band MEASUREMENT OF THE TOTAL CROSS SECTION OF REAL AND VIRTUAL PHOTON ABSORPTION ON URANIUM NUCLEI AT ENERGIES OF HUNDREDS OF GEV.		
	+-----+		
	Request	10 Oct, 88	Unspecified
	Rejected	26 Dec, 89	
802	MUONS IN EMULSION #802	Lali Chatterjee and Dipak Ghosh	FERMILAB JADAVPUR UNIVERSITY (INDIA)
	BEAM: Neutrino Area - Muon Beam DEEP INELASTIC MUON INTERACTION WITH NUCLEAR TARGETS USING EMULSION TELESCOPE TECHNIQUE.		
	+-----+		
	Request	12 Dec, 88	Emulsion Stack(s)
	Approval	8 Feb, 89	Emulsion Stack(s) 1st stage approval - exposure of stacks of G5 nuclear emulsion plates to the main muon beam.
	Completed	30 Dec, 91	Unspecified
803	NEUTRINO OSCILLATIONS #803	Neville W. Reay	AICHI UNIV. OF EDUCATION (JAPAN) UNIVERSITY OF ATHENS (GREECE) UNIV. OF CALIFORNIA, DAVIS UNIV. OF CALIFORNIA, LOS ANGELES CHONNAM NATIONAL UNIVERSITY (KOREA) FERMILAB GIFU UNIVERSITY (JAPAN) GYEONGSANG NATIONAL UNIV. (KOREA) HIROSAKI UNIVERSITY (JAPAN) ILLINOIS INSTITUTE OF TECHNOLOGY INDIANA UNIVERSITY KANSAS STATE UNIVERSITY KINKI UNIVERSITY (JAPAN) KOBE UNIVERSITY (JAPAN) KOREA ADV. INST OF SCIENCE (KOREA) KOREA UNIVERSITY, SEOUL (KOREA) UNIVERSITY OF MICHIGAN - ANN ARBOR ITEP, MOSCOW (RUSSIA) NAGOYA INST. OF TECHNOLOGY (JAPAN) OKAYAMA UNIVERSITY (JAPAN) OSAKA CITY UNIVERSITY (JAPAN) OSAKA SCIENCE EDUC. INST. (JAPAN) OSAKA UNIV. OF COMMERCE (JAPAN) SEOUL NATIONAL UNIVERSITY (KOREA) SOAI UNIVERSITY (JAPAN) UNIVERSITY OF SOUTH CAROLINA TECHNION-ISRAEL INST (ISRAEL) TOHO UNIVERSITY (JAPAN) TUFTS UNIVERSITY UTSUNOMIYA UNIVERSITY (JAPAN) YOKOHAMA NATIONAL UNIV. (JAPAN)
	BEAM: Main Injector Area Muon Neutrino to Tau Neutrino Oscillations		
	+-----+		
	Request	6 Apr, 89	Unspecified
	Unscheduled	24 Nov, 93	
	Withdrawn	9 Mar, 98	
804	KAMI R&D #804	Ronald Ray	UNIVERSITY OF ARIZONA UNIV. OF CALIFORNIA, LOS ANGELES UNIV. ESTADUAL DE CAMPINAS (BRAZIL) UNIVERSITY OF CHICAGO UNIVERSITY OF COLORADO AT BOULDER FERMILAB OSAKA UNIVERSITY IHEP, PROTIVNO (SERPUKHOV) (RUSSIA) RICE UNIVERSITY UNIVERSITE DE SAO PAULO (BRAZIL) UNIVERSITY OF VIRGINIA
	BEAM: Main Injector Area HIGH PRECISION, HIGH SENSITIVITY KAON PHYSICS AT THE MAIN INJECTOR		
	+-----+		
	Request	14 Jun, 88	Unspecified
	Unconsidered	14 Jun, 88	
	Approval	7 Jul, 99	
	In Progress	17 Jan, 00	
	Completed	28 Jun, 01	
805	IMB NEUTRINO OSCILLATIONS #805	Wojciech Gajewski	BOSTON UNIVERSITY BROOKHAVEN NATIONAL LABORATORY UNIV. OF CALIFORNIA, IRVINE CLEVELAND STATE UNIVERSITY UNIVERSITY OF HAWAII AT MANOA LONDON UNIVERSITY COLLEGE (ENGLAND) LOUISIANA STATE UNIVERSITY UNIVERSITY OF MARYLAND NOTRE DAME UNIVERSITY WARSAW UNIVERSITY, INP, (POLAND)
	BEAM: Main Injector Area Long Baseline Oscillation Experiment using a High Intensity Neutrino Beam from the Fermilab Main Injector to the IMB Water Cerenkov Detector		
	+-----+		
	Request	24 Aug, 89	Unspecified
	Inactive	23 Dec, 92	
806	MP BEAMLINE UPGRADE #806	Akihiko Yokosawa	ARGONNE NATIONAL LABORATORY CEN-SACLAY (FRANCE) FERMILAB HIROSHIMA UNIVERSITY (JAPAN) UNIVERSITY OF IOWA KEK (JAPAN) KYOTO SANGYO UNIVERSITY (JAPAN) KYOTO UNIVERSITY (JAPAN) KYOTO UNIV. OF EDUCATION (JAPAN) LAPP, D'ANNECY-LE-VIEUX (FRANCE) LOS ALAMOS NATIONAL LABORATORY NORTHEASTERN UNIVERSITY NORTHWESTERN UNIVERSITY UN. OF OCCUP. & ENV. HEALTH (JAPAN) IHEP, PROTIVNO (SERPUKHOV) (RUSSIA) RICE UNIVERSITY UNIVERSITY DI TRIESTE (ITALY) UNIVERSITY OF UDINE (ITALY)
	BEAM: Meson Area - Polarized Proton Beam ENERGY UPGRADE OF THE MP BEAMLINE AND PROPOSED EXPERIMENTS		
	+-----+		
	Request	28 Sep, 89	Unspecified
	Withdrawn	7 Mar, 90	
807	WARM HEAVY LIQUID CALORIMETRY #T807	Scott Teige	RUTGERS UNIVERSITY
	BEAM: Proton Area - East WARM HEAVY LIQUID CALORIMETRY: A PROPOSAL TO MEASURE PERFORMANCE OF CANDIDATE MATERIALS		
	+-----+		
	Request	26 Dec, 89	Unspecified
	Approval	9 Feb, 90	Unspecified
	Completed	1 May, 90	Unspecified

808	B-PHYSICS #T808 BEAM: Meson Area - West B-MESON HADROPRODUCTION, INCLUDING MEASUREMENTS OF CROSS-SECTIONS, LIFETIMES, AND MIXING.	Howard S. Goldberg	UNIV. OF ILLINOIS, CHICAGO CIRCLE UNIVERSITY OF LOUISVILLE UNIVERSITY OF MICHIGAN - ANN ARBOR UNIVERSITY OF PITTSBURGH IHEP, PROTIVNO (SERPUKHOV) (RUSSIA)
	Request	1 Mar, 90	Unspecified
	Inactive	23 Dec, 92	
809	DIRECT PHOTON SPIN DEPENDENCE #809 BEAM: Meson Area - Polarized Proton Beam STUDY OF THE SPIN DEPENDENCE OF DIRECT-GAMMA PRODUCTION AT HIGH P	Akira Masaike and Sandibek B. (Sergei) Nurushev	ARGONNE NATIONAL LABORATORY CEN-SACLAY (FRANCE) FERMILAB UNIVERSITY OF IOWA KEK (JAPAN) KYOTO SANGYO UNIVERSITY (JAPAN) KYOTO UNIVERSITY (JAPAN) KYOTO UNIV. OF EDUCATION (JAPAN) LAPP, D'ANNECY-LE-VIEUX (FRANCE) LOS ALAMOS NATIONAL LABORATORY INFN, MESSINA (ITALY) NEW MEXICO STATE UNIVERSITY NORTHWESTERN UNIVERSITY OKAYAMA UNIVERSITY (JAPAN) OSAKA CITY UNIVERSITY (JAPAN) IHEP, PROTIVNO (SERPUKHOV) (RUSSIA) RICE UNIVERSITY UNIVERSITY DI TRIESTE (ITALY) UNIVERSITY OF UDINE (ITALY)
	Request	7 Mar, 90	Unspecified
	Inactive	23 Dec, 92	
810	STRUCTURE FUNCTIONS #810 BEAM: Neutrino Area - Muon Beam MEASUREMENT OF NUCLEON STRUCTURE FUNCTIONS WITH HIGH STATISTICAL ACCURACY AND LOW SYSTEMATIC ERRORS, USING MUON BEAMS FROM THE TEVATRON.	Richard Wilson	UNIV. OF CALIFORNIA, SAN DIEGO FERMILAB HARVARD UNIVERSITY UNIV. OF ILLINOIS, CHICAGO CIRCLE UNIVERSITY OF WUPPERTAL (GERMANY)
	Request	5 Mar, 90	Unspecified
	Inactive	23 Dec, 92	
811	PBAR P ELASTIC SCATTERING #811 BEAM: Collision Area (E-0) PBAR P ELASTIC SCATTERING.	Jay Orear	CERN (SWITZERLAND) CORNELL UNIVERSITY FERMILAB
	Request	14 Mar, 90	Unspecified
	Approval	9 Jul, 92	Unspecified
	Data Analysis	20 Feb, 96	
	Completed	1 Mar, 01	
812	CPT AND GRAVITY TESTS #812 BEAM: Accumulator Ring PRECISION TESTS OF CPT AND GRAVITY USING LOW ENERGY ANTIMATTER AT FERMILAB.	Gerald A. Smith	UNIV. OF CALIFORNIA, IRVINE GSI, DARMSTADT (GERMANY) FERMILAB INTEGRATED ACCELERATOR TECHNOLOGY UNIVERSITY OF IOWA LOS ALAMOS NATIONAL LABORATORY MANNE SIEGBAHN INSTITUTE (SWEDEN) MAX-PLANCK INSTITUTE (GERMANY) UNIVERSITY OF MICHIGAN - ANN ARBOR UNIVERSITY OF NEW MEXICO PENNSYLVANIA STATE UNIVERSITY RUTGERS UNIVERSITY UNIVERSITY DI TRIESTE (ITALY)
	Request	19 Feb, 90	Unspecified
	Inactive	30 Jun, 94	
813	SMALL PHYSICS #813 BEAM: Unspecified Beam I. A QUANTITATIVE TEST OF THE LANDAU-MIGDAL-POMMERANCHUK EFFECT; II. HADRON INCLUSIVE DISTRIBUTIONS AT HIGH X; III. NEUTRON POLARIZATION	Lawrence W. Jones	UNIVERSITY OF HAWAII AT MANOA LODZ UNIVERSITY UNIVERSITY OF MICHIGAN - ANN ARBOR UNIVERSITY OF WASHINGTON
	Request	2 Mar, 90	Unspecified
	Rejected	5 May, 93	
814	PRIMAKOFF PRODUCTION #814 BEAM: Proton Area - Center SEARCH FOR PRIMAKOFF PRODUCTION OF HYBRID MESONS.	Vladimir Chaloupka	UNIVERSITY OF ROCHESTER UNIVERSITY OF WASHINGTON
	Request	28 Feb, 90	Unspecified
	Inactive	23 Dec, 92	
815	NEUTRINO #815 BEAM: Neutrino Area - Center Precision Measurements of Neutrino Neutral Current Interactions Using a Sign-Selected Beam	Michael H. Shaevitz and Robert H. Bernstein	UNIVERSITY OF CINCINNATI COLUMBIA UNIVERSITY FERMILAB KANSAS STATE UNIVERSITY NORTHWESTERN UNIVERSITY UNIVERSITY OF OREGON UNIVERSITY OF ROCHESTER XAVIER UNIVERSITY
	Request	7 Mar, 90	Unspecified
		9 Oct, 90	Unspecified
	Approval	10 Jul, 91	Unspecified Stage I approval for Phase I granted.
		9 Jul, 92	Unspecified Stage I approval for 10 E18th Protons on target
		24 Jun, 94	Unspecified 1E18 protons on target at an intensity between 1 and 3 E13 protons / pulse
	In Progress	15 Jun, 96	
	Data Analysis	5 Sep, 97	
	Completed	5 Mar, 05	
816	SDC DETECTOR MUON BEAM TESTS #T816 BEAM: Neutrino Area - Muon Beam SSC Detector Muon Sub-System Beam Tests	Henry J. Lubatti	UNIVERSITY OF COLORADO AT BOULDER FERMILAB UNIVERSITY OF ILLINOIS, CHAMPAIGN UNIVERSITY OF MARYLAND OSAKA CITY UNIVERSITY (JAPAN) UNIVERSITY OF ROCHESTER TEMPLE UNIVERSITY TUFTS UNIVERSITY UNIVERSITY OF WASHINGTON UNIVERSITY OF WISCONSIN - MADISON
	Request	1 May, 90	Unspecified
	Approval	30 Oct, 90	Unspecified
	Completed	8 Jan, 92	Unspecified

817	SILICON STRIP DETECTOR TEST #817 BEAM: Neutrino Area - Muon Beam Double-sided silicon strip detector prototype evaluation. +-----+ Request 1 May, 90 Unspecified Approval 9 Jul, 90 Unspecified Completed 15 Aug, 90 Unspecified	James P. Alexander	UNIV. OF CALIFORNIA, SANTA BARBARA CORNELL UNIVERSITY
818	LEAD GLASS DETECTOR TEST #818 BEAM: Unspecified Beam Proposal to use the NWA Electron Test Beam at Fermilab for Tests of a Lead Glass Calorimeter Prototype +-----+ Request 26 Jun, 90 Unspecified Withdrawn 30 Apr, 91	Scott Teige	INDIANA UNIVERSITY UNIVERSITY OF LOUISVILLE MOSCOW STATE UNIVERSITY (RUSSIA) IHEP, PROTIVNO (SERPUKHOV) (RUSSIA)
819	EMPACT DETECTOR TEST FOR SSC #819 BEAM: Neutrino Area - Muon Beam EMPACT Muon Telescope Evaluation at Fermilab +-----+ Request 28 Jun, 90 Unspecified Approval 15 Aug, 91 Unspecified Completed 15 Oct, 91 Unspecified	Louis S. Osborne	UNIVERSITY OF HOUSTON INDIANA UNIVERSITY JINR, DUBNA (RUSSIA) MASSACHUSETTS INST. OF TECHNOLOGY
820	MUON NEUTRINO MAGNETIC MOMENT #820 BEAM: Miscellaneous Area Search for the muon neutrino magnetic moment at the 10 to the -10 Bohr magneton level using the Booster at Fermilab +-----+ Request 13 Jul, 90 Unspecified Inactive 30 Jun, 94	Nikos D. Giokaris	FERMILAB UNIVERSITY OF MARYLAND NORTHEASTERN UNIVERSITY NORTHERN ILLINOIS UNIVERSITY UNIVERSITY OF ROCHESTER ROCKEFELLER UNIVERSITY
821	NEUTRON MEASUREMENTS AT NWA #821 BEAM: Neutrino Area - West Neutron Measurements at NWA +-----+ Request 14 Aug, 90 Unspecified Approval 14 Aug, 90 Unspecified Completed 8 Jan, 92 Unspecified	Kenneth A. Johns	UNIVERSITY OF ARIZONA BALL STATE UNIVERSITY FERMILAB UNIVERSITY OF MICHIGAN - ANN ARBOR UNIVERSITY OF MINNESOTA NORTHERN ILLINOIS UNIVERSITY RICE UNIVERSITY
822	NEUTRINO OSCILLATIONS #822 BEAM: Main Injector Area A Long-Baseline Neutrino Oscillation Experiment from Fermilab to Soudan +-----+ Request 24 Aug, 90 Unspecified Withdrawn 24 Oct, 95	Maury C. Goodman	ARGONNE NATIONAL LABORATORY FERMILAB LEBEDEV PHYSICAL INST. (RUSSIA) UNIVERSITY OF MINNESOTA ITEP, MOSCOW (RUSSIA) UNIVERSITY OF OXFORD (ENGLAND) RUTHERFORD-APPLETON LABS. (ENGLAND) SSC LABORATORY TEXAS A&M UNIVERSITY TUFTS UNIVERSITY WESTERN WASHINGTON UNIVERSITY

823	D-0 DETECTOR UPGRADE #823 BEAM: Collision Area (D-0) D0 Detector Upgrade	Gerald Blazey and Terry Wyatt	INST.OF PHYS.ACADEMY OF SCI (CZECH) UNIVERSITY OF ALBERTA (CANADA) UNIVERSIDAD DE LOS ANDES (COLOMBIA) UNIVERSITY OF ARIZONA UNIVERSITY OF BONN (GERMANY) BOSTON UNIVERSITY BROOKHAVEN NATIONAL LABORATORY BROWN UNIVERSITY UNIV. DE BUENOS AIRES (ARGENTINA) CALIFORNIA STATE UNIVERSITY UNIV. OF CALIFORNIA, RIVERSIDE CBPF (BRAZIL) CEA-SACLAY (FRANCE) CPM, MARSEILLE (FRANCE) CHARLES UNIVERSITY (CZECH) CINVESTAV-IPN (MEXICO) LPN, UNIV. DE CLERMONT (FRANCE) COLUMBIA UNIVERSITY CZECH TECHNICAL UNIVERSITY (CZECH) DELHI UNIVERSITY (INDIA) UNIVERSITY COLLEGE DUBLIN (IRELAND) FERMILAB FLORIDA STATE UNIVERSITY FREIBURG UNIVERSITY (GERMANY) UNIV. OF ILLINOIS, CHICAGO CIRCLE IMPERIAL COLLEGE (ENGLAND) INDIANA UNIVERSITY INS RECHERCHES SUBATOMIQUE (FRANCE) ISN (GRENOBLE, FRANCE) IPNL (FRANCE) IOWA STATE UNIVERSITY JINR, DUBNA (RUSSIA) KANSAS STATE UNIVERSITY UNIVERSITY OF KANSAS KOREA UNIVERSITY, SEOUL (KOREA) LAL, ORSAY (FRANCE) LANCASTER UNIVERSITY (ENGLAND) LANGSTON UNIVERSITY LAWRENCE BERKELEY NATIONAL LAB. LOUISIANA TECH UNIVERSITY LPNHE, UN. OF P & M CURIE (FRANCE) LUDWIG MAXIMILIANS UNIV. (GERMANY) LUND, RIT, STOCKHOLM, UPPSALA (SWEDEN) MAINZ UNIVERSITY (GERMANY) UNIVERSITY OF MANCHESTER (ENGLAND) UNIVERSITY OF MARYLAND UNIVERSITY OF MICHIGAN - ANN ARBOR MICHIGAN STATE UNIVERSITY UNIVERSITY OF MISSISSIPPI MOSCOW STATE UNIVERSITY (RUSSIA) ITEP, MOSCOW (RUSSIA) UNIVERSITY OF NEBRASKA - LINCOLN SUNY AT BUFFALO SUNY AT STONY BROOK UN OF NIJMEGEN/NIKHEF (NETHERLANDS) NIKHEF&U OF AMSTERDAM (NETHERLANDS) NORTHEASTERN UNIVERSITY NORTHERN ILLINOIS UNIVERSITY NORTHWESTERN UNIVERSITY UNIVERSITY OF NOTRE DAME OKLAHOMA STATE UNIVERSITY UNIVERSITY OF OKLAHOMA PANJAB UNIVERSITY (INDIA) UNESP (BRAZIL) PNPI, ST. PETERSBURG (RUSSIA) PRINCETON UNIVERSITY PURDUE UNIVERSITY - CALUMET IHEP, PROTIVNO (SERPUKHOV) (RUSSIA) RICE UNIVERSITY UN. ESTADO RIO DE JANEIRO (BRAZIL) UNIVERSITY OF ROCHESTER RWTH, AACHEN (GERMANY) UN.SAN FRANCISCO DE QUITO (ECUADOR) UNIV. OF SCI. & TECH., HEFEI (PRC) SIMON FRASER UNIVERSITY (CANADA) SOUTHERN METHODIST UNIVERSITY SUNG KYUN KWAN UNIVERSITY (KOREA) TATA INSTITUTE (INDIA) UNIVERSITY OF TEXAS AT ARLINGTON UNIVERSITY OF VIRGINIA UNIVERSITY OF WASHINGTON UNIVERSITY OF WUPPERTAL (GERMANY)
	Request 4 Oct, 90 Unspecified Approval 11 Jul, 91 Unspecified Unscheduled 11 Jul, 91 Setup in a Year 1 Mar, 99 In Progress 1 Mar, 01	Stage I / Step 1 approval granted Stage I / Step 2 and 3 approval deferred	
824	DUMAND NEUTRINO OSCILLATIONS #824 BEAM: Main Injector Area Neutrino Beam from the Proposed Main Injector to the DUMAND Detector	Medford S. Webster	RWTH, AACHEN (GERMANY) UNIVERSITY OF BERNE (SWITZERLAND) BOSTON UNIVERSITY UNIVERSITY OF HAWAII AT MANOA ICRR, UNIVERSITY OF TOKYO (JAPAN) UNIVERSITY OF KIEL (GERMANY) KINKI UNIVERSITY (JAPAN) KOBE UNIVERSITY (JAPAN) SCRIPPS INST. OF OCEANOGRAPHY/UCSD TOHOKU UNIVERSITY (JAPAN) VANDERBILT UNIVERSITY UNIVERSITY OF WASHINGTON UNIVERSITY OF WISCONSIN - MADISON
	Request 4 Oct, 90 Unspecified Inactive 23 Dec, 92		

825	SDC PROTOTYPE DETECTORS #825	James R. Bensinger	ARGONNE NATIONAL LABORATORY UNIVERSITY OF ARIZONA BRANDEIS UNIVERSITY BRATSLAVA STATE UNIVERSITY (CZECH) UNIVERSITY OF BRISTOL (ENGLAND) BROWN UNIVERSITY UNIV. OF CALIFORNIA, DAVIS UNIV. OF CALIFORNIA, LOS ANGELES UNIV. OF CALIFORNIA, RIVERSIDE UNIV. OF CALIFORNIA, SAN DIEGO UNIV. OF CALIFORNIA, SANTA CRUZ CHIBA UNIVERSITY (JAPAN) UNIVERSITY OF CHICAGO UNIVERSITY OF COLORADO AT BOULDER DUKE UNIVERSITY FERMILAB FLORIDA STATE UNIVERSITY UNIVERSITY OF FLORIDA FUKUI UNIVERSITY (JAPAN) GOMEL STATE UNIVERSITY (BYELARUS) HARVARD UNIVERSITY UNIVERSITY OF HAWAII AT MANOA HIROSHIMA INST. OF TECH. (JAPAN) HIROSHIMA UNIVERSITY (JAPAN) IBARAKI COLLEGE OF TECH. (JAPAN) UNIV. OF ILLINOIS, CHICAGO CIRCLE UNIVERSITY OF ILLINOIS, CHAMPAIGN INDIANA UNIVERSITY IOWA STATE UNIVERSITY JINR, DUBNA (RUSSIA) JOHNS HOPKINS UNIVERSITY KEK (JAPAN) KYOTO UNIVERSITY (JAPAN) LAWRENCE BERKELEY LABORATORY UNIVERSITY OF LIVERPOOL (ENGLAND) UNIVERSITY OF MARYLAND UNIVERSITY OF MICHIGAN - ANN ARBOR UNIVERSITY OF MINNESOTA ACADEMY OF SCI. OF BSSR (BYELARUS) UNIVERSITY OF MISSISSIPPI MIYAZAKI UNIVERSITY (JAPAN) NAGOYA UNIVERSITY (JAPAN) NIIGATA UNIVERSITY (JAPAN) NOTRE DAME UNIVERSITY OAK RIDGE NATIONAL LABORATORY OHIO STATE UNIVERSITY OKAYAMA UNIVERSITY (JAPAN) OSAKA CITY UNIVERSITY (JAPAN) OSAKA UNIVERSITY (JAPAN) UNIVERSITY OF OXFORD (ENGLAND) PENNSYLVANIA STATE UNIVERSITY UNIVERSITY OF PENNSYLVANIA UNIVERSITY OF PISA (ITALY) UNIVERSITY OF PITTSBURGH PURDUE UNIVERSITY RICE UNIVERSITY UNIVERSITY OF ROCHESTER ROCKEFELLER UNIVERSITY RUTGERS UNIVERSITY RUTHERFORD-APPLETON LABS. (ENGLAND) SAGA UNIVERSITY (JAPAN) SAITAMA COLLEGE OF HEALTH (JAPAN) SLOVAK ACADEMY OF SCIENCE (CZECH) SOFIA STATE UNIVERSITY (BULGARIA) SSC LABORATORY SLAC TASHKENT, PHY.TEC.INS (UZBEKISTAN) IHEP, TBILISI STATE UNIV (GEORGIA) TEXAS A&M UNIVERSITY UNIVERSITY OF TEXAS AT DALLAS TOHOKU GAKUIN UNIVERSITY (JAPAN) TOHOKU UNIVERSITY (JAPAN) TOKYO INST. OF TECHNOLOGY (JAPAN) TOKYO METROPOLITAN UNIV. (JAPAN) TOKYO UNIV. OF AGR. & TECH. (JAPAN) UNIVERSITY OF TOKYO (JAPAN) UNIVERSITY OF TSUKUBA (JAPAN) TUFTS UNIVERSITY VIRGINIA TECH WAKAYAMA MEDICAL COLLEGE (JAPAN) UNIVERSITY OF WASHINGTON UNIVERSITY OF WISCONSIN - MADISON YEREVAN PHYSICS INST. (ARMENIA)
826	HYPERON MEASUREMENTS #826	Kenneth A. Johns and Regina A. Rameika	UNIVERSITY OF ARIZONA FERMILAB UNIVERSITY OF MICHIGAN - ANN ARBOR UNIVERSITY OF MINNESOTA

827	MICRO-BCD #827	Nigel S. Lockyer	UNIVERSIDAD DE LOS ANDES (COLOMBIA) UNIV. OF CALIFORNIA, DAVIS FERMILAB UNIVERSITY OF FLORIDA UNIV. OF ILLINOIS, CHICAGO CIRCLE ILLINOIS INSTITUTE OF TECHNOLOGY UNIVERSITY OF IOWA UNIVERSITY OF MONTREAL (CANADA) SUNY AT ALBANY OAK RIDGE NATIONAL LABORATORY UNIVERSITY OF OKLAHOMA UNIVERSITY OF PENNSYLVANIA PRAIRIE VIEW A&M UNIVERSITY PRINCETON UNIVERSITY UNIV. OF PUERTO RICO - RIO PIEDRAS UN.SAN FRANCISCO DE QUITO(ECUADOR) SPACE SCIENCE LAB., U.C., BERKELEY UNIVERSITY OF WISCONSIN - MADISON YALE UNIVERSITY
	BEAM: Collision Area (C-0) B Physics at the TEV I; Micro-BCD		
	Request	8 Oct, 90	Unspecified
	Rejected	10 Jul, 91	
828	B-MESON CP VIOLATION #828	Sheldon L. Stone	FERMILAB UNIVERSITY OF FLORIDA UNIVERSITY OF MICHIGAN - ANN ARBOR SYRACUSE UNIVERSITY
	BEAM: Collision Area (Miscellaneous) Letter of Intent to Measure CP Violation in B Meson Decay at the Fermilab Collider		
	Request	26 Sep, 90	Unspecified
	Withdrawn	22 Jun, 91	
829	HEAVY FLAVORS AT TPL #829	David C. Christian and Michael D. Sokoloff	UNIVERSITY OF CINCINNATI CINVESTAV-IPN (MEXICO) FERMILAB ILLINOIS INSTITUTE OF TECHNOLOGY UNIVERSITY OF MASSACHUSETTS PRINCETON UNIVERSITY UN.AUTONOMA DE PUEBLA (MEXICO) UNIVERSITY OF TEL-AVIV (ISRAEL) TUFTS UNIVERSITY UNIVERSITY OF WISCONSIN - MADISON YALE UNIVERSITY
	BEAM: Proton Area - East Study of Heavy Flavors at TPL, Continuation of E-791		
	Request	8 Oct, 90	Unspecified
	Rejected	28 Feb, 94	
830	CDF UPGRADE #830	Jacobo Konigsberg and Robert Roser	IHEP, ACADEMIA SINICA (TAIWAN) ARGONNE NATIONAL LABORATORY UNIVERSITY OF BARCELONA (SPAIN) BAYLOR UNIVERSITY UNIVERSITY OF BOLOGNA (ITALY) BRANDEIS UNIVERSITY UNIV. OF CALIFORNIA, DAVIS UNIV. OF CALIFORNIA, LOS ANGELES UNIV. OF CALIFORNIA, SAN DIEGO UNIV. OF CALIFORNIA, SANTA BARBARA UNIVERSITY OF CANTABRIA (SPAIN) CARNEGIE-MELLON UNIVERSITY UNIVERSITY OF CHICAGO CIEMAT, MADRID, SPAIN (SPAIN) COMENIUS UNIVERSITY (SLOVAKIA) DUKE UNIVERSITY FERMILAB UNIVERSITY OF FLORIDA INFN, FRASCATI (ITALY) UNIVERSITY OF GENEVA (SWITZERLAND) GLASGOW UNIVERSITY (SCOTLAND) HARVARD UNIVERSITY UNIVERSITY OF HELSINKI (FINLAND) UNIVERSITY OF ILLINOIS, CHAMPAIGN INFN, TRIESTE/UNIV DI UDINE (ITALY) IPP/MCGILL U/UN OF TORONTO (CANADA) JINR, DUBNA (RUSSIA) JOHNS HOPKINS UNIVERSITY UNIVERSITY OF KARLSRUHNE (GERMANY) KOREA CENTER FOR HEP (KOREA) LAWRENCE BERKELEY NATIONAL LAB. UNIVERSITY OF LIVERPOOL (ENGLAND) UNIVERSITY COLLEGE LONDON (ENGLAND) LPNHE, UN. OF P & M CURIE (FRANCE) MASSACHUSETTS INST. OF TECHNOLOGY UNIVERSITY OF MICHIGAN - ANN ARBOR MICHIGAN STATE UNIVERSITY ITEP, MOSCOW (RUSSIA) UNIVERSITY OF NEW MEXICO NORTHWESTERN UNIVERSITY OHIO STATE UNIVERSITY OKAYAMA UNIVERSITY (JAPAN) OSAKA CITY UNIVERSITY (JAPAN) UNIVERSITY OF OXFORD (ENGLAND) UNIVERSITY OF PADOVA (ITALY) UNIVERSITY OF PENNSYLVANIA INFN, PISA (ITALY) UNIVERSITY OF PITTSBURGH PURDUE UNIVERSITY UNIVERSITY OF ROCHESTER ROCKEFELLER UNIVERSITY UNIVERSITY OF ROME (ITALY) RUTGERS UNIVERSITY TEXAS A&M UNIVERSITY UNIVERSITY OF TSUKUBA (JAPAN) TUFTS UNIVERSITY WASEDA UNIVERSITY (JAPAN) WAYNE STATE UNIVERSITY UNIVERSITY OF WISCONSIN - MADISON YALE UNIVERSITY
	BEAM: Collision Area (B-0) Proposal for an Upgraded CDF Detector		
	Request	9 Oct, 90	Unspecified
	Unscheduled	11 Jul, 91	
	Setup in a Year	1 Mar, 99	
	In Progress	1 Mar, 01	

831	HEAVY QUARK PHOTOPRODUCTION #831 BEAM: Proton Area - Broad Band A High Statistics Study of States Containing Heavy Quarks Using the Wideband Photon Beam and the E687 Multiparticle Spectrometer	John P. Cumalat and Luigi Moroni	UNIV. OF CALIFORNIA, DAVIS CBPF (BRAZIL) CINVESTAV-IPN (MEXICO) UNIVERSITY OF COLORADO AT BOULDER FERMILAB INFN, FRASCATI (ITALY) UNIVERSITY OF ILLINOIS, CHAMPAIGN KOREA UNIVERSITY, SEOUL (KOREA) INFN, MILANO (ITALY) UNIVERSITY OF MILANO (ITALY) UNIVERSITY OF NORTH CAROLINA UNIVERSITY OF PAVIA (ITALY) UN.AUTONOMA DE PUEBLA (MEXICO) UNIV. OF PUERTO RICO - MAYAGUEZ UNIVERSITY OF SOUTH CAROLINA UNIVERSITY OF TENNESSEE, KNOXVILLE VANDERBILT UNIVERSITY UNIVERSITY OF WISCONSIN - MADISON YEONSEI UNIVERSITY (KOREA)
	Request	17 Oct, 90 1 Sep, 92	Unspecified 5,000 Hours 1000 hours for setup and 4000 hours for data taking
	Approval	7 Dec, 92	Unspecified
	In Progress	15 Sep, 96	
	Data Analysis	25 Aug, 97	
832	CP VIOLATION #832 BEAM: Neutrino Area - Muon Beam Proposal for a New Tevatron Search for Direct CP Violation in the 2pi decays of the Neutral Kaon	Edward C. Blucher	UNIVERSITY OF ARIZONA UNIV. OF CALIFORNIA, LOS ANGELES UNIV. OF CALIFORNIA, SAN DIEGO UNIV. ESTADUAL DE CAMPINAS (BRAZIL) UNIVERSITY OF CHICAGO UNIVERSITY OF COLORADO AT BOULDER ELMHURST COLLEGE FERMILAB OSAKA UNIVERSITY (JAPAN) RICE UNIVERSITY RUTGERS UNIVERSITY UNIVERSITE DE SAO PAULO (BRAZIL) UNIVERSITY OF VIRGINIA UNIVERSITY OF WISCONSIN - MADISON
	Request	18 Oct, 90	Unspecified
	Approval	1 Jun, 92	
	In Progress	26 Oct, 96	
	Data Analysis	17 Jan, 00	
833	K-SHORT DECAYS #833 BEAM: Meson Area - Center Letter of Intent to Measure the Branching Ratio for the K-short Decay	Gordon B. Thomson	UNIV. OF CALIFORNIA, LOS ANGELES UNIVERSITY OF CHICAGO ELMHURST COLLEGE FERMILAB UNIVERSITY OF ILLINOIS, CHAMPAIGN RUTGERS UNIVERSITY
	Request	19 Oct, 90	Unspecified
	Inactive	30 Aug, 95	
834	DIRECT PHOTON #834 BEAM: Meson Area - West Direct Photon Production #834	Paul F. Slattery	DELHI UNIVERSITY (INDIA) FERMILAB MICHIGAN STATE UNIVERSITY UNIVERSITY OF MINNESOTA NORTHEASTERN UNIVERSITY PENNSYLVANIA STATE UNIVERSITY UNIVERSITY OF PITTSBURGH RAJASTHAN UNIVERSITY (INDIA) UNIVERSITY OF ROCHESTER
	Request	19 Oct, 90	Unspecified
	Inactive	23 Dec, 92	
835	CHARMONIUM STATES #835 BEAM: Accumulator Ring Study of Charmonium States formed in Antiproton-proton Annihilations MOU Executed.	Rosanna Cester and Stephen H. Pordes	UNIV. OF CALIFORNIA, IRVINE FERMILAB UNIVERSITY OF FERRARA (ITALY) INFN, GENOVA (ITALY) UNIVERSITY OF MINNESOTA NORTHWESTERN UNIVERSITY UNIVERSITY OF TORINO (ITALY)
	Request	16 Oct, 90	Unspecified
	Approval	7 Dec, 92	Unspecified
	In Progress	1 Oct, 96	
	Data Analysis	8 Nov, 00	
	Completed	1 Jan, 06	
836	SUPERCONDUCTING DETECTOR TEST #836 BEAM: Unspecified Beam Proposal for a Beam Test of a Superconducting Thin Film Strip Particle Detector	Robert G. Wagner	ARGONNE NATIONAL LABORATORY
	Request	3 Oct, 90	24 Hours in three 8 hour shifts
	Withdrawn	8 Jan, 92	
837	EMPACT/TEXAS TEST #837 BEAM: Unspecified Beam EMPACT/TEXAS Beam Test(s)	Michael D. Marx	SUNY AT STONY BROOK
	Request	12 Oct, 90	Unspecified
	Inactive	23 Dec, 92	
838	POLARIZED BEAM #838 BEAM: Meson Area - Polarized Proton Beam Continuation of E-704 and Simultaneous Measurement of Chi-2 Production	Akihiko Yokosawa	ARGONNE NATIONAL LABORATORY CEN-SACLAY (FRANCE) FERMILAB UNIVERSITY OF IOWA KYOTO SANGYO UNIVERSITY (JAPAN) KYOTO UNIVERSITY (JAPAN) KYOTO UNIV. OF EDUCATION (JAPAN) LAPP, D'ANNEY-LE-VIEUX (FRANCE) LOS ALAMOS NATIONAL LABORATORY INFN, MESSINA (ITALY) NEW MEXICO STATE UNIVERSITY NORTHWESTERN UNIVERSITY UN. OF OCCUP. & ENV. HEALTH (JAPAN) OKAYAMA UNIVERSITY (JAPAN) OLD DOMINION UNIVERSITY OSAKA CITY UNIVERSITY (JAPAN) OSAKA UNIV. OF COMMERCE (JAPAN) IHEP, PROTIVNO (SERPUKHOV) (RUSSIA) RICE UNIVERSITY UNIVERSITY DI TRIESTE (ITALY) UNIVERSITY OF UDINE (ITALY)
	Request	1 Oct, 90	Unspecified
	Rejected	19 Feb, 91	

839	FIBER TRACKING TEST #839 BEAM: Neutrino Area - Muon Beam Scintillating Fiber Tracker - Beam Test +-----+ Request 25 Sep, 90 Unspecified Approval 15 Apr, 91 Unspecified Completed 8 Jan, 92 Unspecified	Seymour Margulies	UNIV. OF CALIFORNIA, LOS ANGELES FERMILAB UNIV. OF ILLINOIS, CHICAGO CIRCLE NOTRE DAME UNIVERSITY OSAKA CITY UNIVERSITY (JAPAN) PENNSYLVANIA STATE UNIVERSITY PURDUE UNIVERSITY RICE UNIVERSITY UNIVERSITY OF TEXAS AT DALLAS UNIVERSITY OF TSUKUBA (JAPAN)
840	SPAGHETTI CALORIMETRY TEST #840 BEAM: Meson Area - Polarized Proton Beam Spaghetti calorimetry in '91 test beam cycle +-----+ Request 11 Oct, 90 592 Hours Approval 8 Aug, 91 Unspecified Completed 8 Jan, 92 Unspecified	Adam Para	FERMILAB 1. Systematic studies of the laminated prototype (160 hrs.) 2. Studies of the RGB prototype (56 hrs.) 3. Dichromatic calorimeter (80 hrs.) 4. Liquid scintillator prototype (56 hrs.) 5. Two-segment fiber prototype (240 hrs.)
841	CALORIMETER BEAM TEST #T841 BEAM: Meson Area - Test Beam Proposal for Beam Test of Scintillator Calorimeter Prototypes at Fermilab during FY 1991 +-----+ Request 8 Oct, 90 Unspecified Approval 28 Mar, 91 Unspecified Completed 8 Jan, 92 Unspecified	Lawrence E. Price	ARGONNE NATIONAL LABORATORY CEN-SACLAY (FRANCE) FERMILAB IOWA STATE UNIVERSITY LAWRENCE BERKELEY LABORATORY NORTHEASTERN UNIVERSITY PURDUE UNIVERSITY UNIVERSITY OF ROCHESTER ROCKEFELLER UNIVERSITY UNIVERSITY OF SOUTH CAROLINA VIRGINIA TECH WESTINGHOUSE ELECTRIC CORPORATION UNIVERSITY OF WISCONSIN - MADISON YALE UNIVERSITY
842	RADIATION EXPOSURE #842 BEAM: Proton Area - Broad Band Proposed Radiation Measurement in the Wideband Neutral Dump Area +-----+ Request 6 Nov, 90 Unspecified Approval 15 Aug, 91 Unspecified Completed 8 Jan, 92 Unspecified	David G. Underwood	ARGONNE NATIONAL LABORATORY
843	EMULSION EXPOSURE 600 GeV #843 BEAM: Neutrino Area - Muon Beam Interactions of 600 GeV Muons with Emulsion Nuclei +-----+ Request 24 Oct, 90 Unspecified Approval 1 Jul, 91 Unspecified Completed 13 Jul, 91 Unspecified	C. O. Kim	CHONNAM NATIONAL UNIVERSITY (KOREA) KOREA UNIVERSITY, SEOUL (KOREA)
844	TRD/SHOWER COUNTER TEST #844 BEAM: Meson Area - Polarized Proton Beam Transition Radiation Detector/EM Shower Counter Calibration +-----+ Request 28 Nov, 90 40 Hours Approval 11 Oct, 91 Unspecified Completed 26 Dec, 91 Unspecified	Simon P. Swordy	UNIVERSITY OF CHICAGO
845	TEVATRON BEAUTY #845 BEAM: Unspecified Beam A Dedicated Beauty Experiment for the Tevatron Collider +-----+ Request 7 Jan, 91 Unspecified Rejected 10 Jul, 91	Peter E. Schlein	UNIV. OF CALIFORNIA, LOS ANGELES CERN (SWITZERLAND) COLLEGE DE FRANCE (FRANCE) INP, KRAKOW (POLAND) MAX-PLANCK INSTITUTE (GERMANY) NANJING UNIVERSITY (PRC) IHEP, PROTIVNO (SERPUKHOV) (RUSSIA) YALE UNIVERSITY
846	FRACTIONAL CHARGE IMPURITIES #846 BEAM: Meson Area - West Search for Fractional Charge Impurities +-----+ Request 1 Feb, 91 Unspecified Inactive 23 Dec, 92	Unil Perera	UNIVERSITY OF PITTSBURGH
847	CALORIMETER TEST #847 BEAM: Unspecified Beam Beam Test for scintillating fiber / lead alloy calorimeter prototype +-----+ Request 13 Feb, 91 Unspecified Completed 8 Jan, 92	Lawrence R. Sulak	BOSTON UNIVERSITY
848	GAS CALORIMETRY FOR SDC #848 BEAM: Neutrino Area - Test Beam High Pressure Sampling Gas Calorimetry for the SDC Calorimeter +-----+ Request 29 Mar, 91 Unspecified Approval 29 Oct, 91 Unspecified Completed 23 Dec, 91 Unspecified	Nikos D. Giokaris	ABILITY ENGINEERING TECHNOLOGY FERMILAB JINR, DUBNA (RUSSIA) UNIVERSITY OF ROCHESTER ROCKEFELLER UNIVERSITY UNIVERSITY OF WISCONSIN - MADISON YEREVAN PHYSICS INST. (ARMENIA)
849	BIARIUM FLUORIDE CALORIMETER #849 BEAM: Neutrino Area - Test Beam Request for Test Beam Time for Barium Fluoride Calorimeter Development +-----+ Request 11 Apr, 91 Unspecified Approval 18 Sep, 91 Unspecified Completed 8 Jan, 92 Unspecified	Hans G. E. Kobrak	BROOKHAVEN NATIONAL LABORATORY CALIFORNIA INSTITUTE OF TECHNOLOGY UNIV. OF CALIFORNIA, SAN DIEGO CARNEGIE-MELLON UNIVERSITY OAK RIDGE NATIONAL LABORATORY PRINCETON UNIVERSITY TATA INSTITUTE (INDIA) Two (2) "beam on" periods of about 1 month each, separated by a data analysis period of about 1 month

850	DIAMOND RADIATION DETECTOR TEST #850	Melissa Franklin	UNIV. OF CALIFORNIA, SANTA BARBARA HARVARD UNIVERSITY KEK (JAPAN) LAWRENCE LIVERMORE LABORATORY OHIO STATE UNIVERSITY PRINCETON UNIVERSITY UNIVERSITY OF ROCHESTER RUTGERS UNIVERSITY SSC LABORATORY STANFORD UNIVERSITY
	BEAM: Meson Area - Test Beam Fermilab Test Beam Time of Diamond Radiation Detectors		
	+-----+		
	Request	1 May, 91	Unspecified
	Approval	8 Jan, 92	Unspecified
	Withdrawn	8 Jan, 92	Unspecified
851	FIBER IRRADIATION STUDIES #851	Seymour Margulies and Jadwiga Warchol	UNIV. OF CALIFORNIA, LOS ANGELES FERMILAB UNIV. OF ILLINOIS, CHICAGO CIRCLE NOTRE DAME UNIVERSITY OAK RIDGE NATIONAL LABORATORY OSAKA CITY UNIVERSITY (JAPAN) PENNSYLVANIA STATE UNIVERSITY PURDUE UNIVERSITY RICE UNIVERSITY UNIVERSITY OF TEXAS AT DALLAS UNIVERSITY OF TSUKUBA (JAPAN)
	BEAM: Collision Area (C-0) Fiber Irradiation Studies in the C0 Region		
	+-----+		
	Request	1 May, 91	Unspecified
	Approval	14 Aug, 91	Unspecified
	Completed	8 Jan, 92	Unspecified
852	PIXEL DETECTOR TEST #T852	Eric Arens	FERMILAB LAWRENCE BERKELEY LABORATORY
	BEAM: Neutrino Area - Muon Beam Pixel Detector Test at NM		
	+-----+		
	Request	8 May, 91	Unspecified
	Approval	9 Sep, 91	Unspecified
	Completed	23 Dec, 91	Unspecified
853	TEVATRON CRYSTAL EXTRACTION #853	C. Thornton Murphy	ARGONNE NATIONAL LABORATORY UNIV. OF CALIFORNIA, LOS ANGELES FAIRFIELD UNIVERSITY FERMILAB JINR, DUBNA (RUSSIA) UNIVERSITY OF NEW MEXICO SUNY AT ALBANY PNPI, ST. PETERSBURG (RUSSIA) IHEP, PROTIVNO (SERPUKHOV) (RUSSIA) SOUTHWESTERN MEDICAL CENTER UNIVERSITY OF TEXAS AT AUSTIN VANDERBILT UNIVERSITY UNIVERSITY OF VIRGINIA
	BEAM: Collision Area (C-0) A Test of Low Intensity Extraction from the Tevatron Using Channeling in a Bent Crystal		
	+-----+		
	Request	22 May, 91	100 Hours of dedicated Tevatron time, during which only protons need to be circulating
		10 May, 93	72 Hours
	Approval	10 May, 93	72 Hours
	Data Analysis	20 Feb, 96	
	Completed	1 Mar, 01	
854	MUON FLUXES IN THE DEBUNCHER #854	Alan D. Bross	COLUMBIA UNIVERSITY FERMILAB
	BEAM: Debuncher Ring Proposal to Measure the Flux of Circulating Muons in the Debuncher.		
	+-----+		
	Request	11 Jul, 91	Unspecified
	Approval	8 Jan, 92	Unspecified
	Completed	8 Jan, 92	Unspecified
855	dE/dx MUONS #855	George R. Kalbfleisch	UNIVERSITY OF OKLAHOMA SSC LABORATORY
	BEAM: Neutrino Area - Muon Beam Test Beam Request to Directly Measure dE/dx of High Energy Muons from 150 to 650 GeV/c in Muon Laboratory		
	+-----+		
	Request	3 Aug, 91	Unspecified
	Approval	18 Nov, 91	Unspecified
	Completed	8 Jan, 92	Unspecified
856	INTEGRATED PIXEL DETECTOR TEST#856	Sherwood I. Parker	UNIVERSITY OF HAWAII AT MANOA LAWRENCE BERKELEY LABORATORY STANFORD UNIVERSITY
	BEAM: Neutrino Area - Muon Beam An Integrated Pixel Detector - Test Beam Request		
	+-----+		
	Request	4 Oct, 91	Unspecified
	Approval	11 Oct, 91	Unspecified
	Completed	8 Jan, 92	Unspecified
857	SPIN-TENSOR #857	L. I. Sarycheva	MOSCOW STATE UNIVERSITY (RUSSIA)
	BEAM: Unspecified Beam Proposal to measure all components of the depolarization tensor.		
	+-----+		
	Request	10 Dec, 91	Unspecified
	Inactive	23 Dec, 92	
858	ELASTIC SCATTERING SPIN EFFECTS #858	Alan D. Krisch	FERMILAB INDIANA UNIVERSITY JINR, DUBNA (RUSSIA) KEK (JAPAN) UNIVERSITY OF MICHIGAN - ANN ARBOR MOSCOW STATE UNIVERSITY (RUSSIA) UNIVERSITY OF NORTH CAROLINA IHEP, PROTIVNO (SERPUKHOV) (RUSSIA)
	BEAM: Unspecified Beam Spin Effects in High Proton-Proton Elastic Scattering		
	+-----+		
	Request	6 Jan, 92	Unspecified
	Rejected	30 Jul, 92	
859	CP VIOLATION IN HYPERON DECAY #859	Shao Yuan Hsueh	FERMILAB
	BEAM: Unspecified Beam CP Violations in Hyperon Decay		
	+-----+		
	Request	2 Jan, 92	Unspecified
	Withdrawn	13 Jan, 94	
860	SEARCH FOR NEUTRINO OSCILLATIONS#860	Wonyong Lee	BROOKHAVEN NATIONAL LABORATORY COLUMBIA UNIVERSITY FERMILAB KANGNUNG NATIONAL UNIV. (KOREA) KOREA UNIVERSITY, SEOUL (KOREA) SEOUL NATIONAL UNIVERSITY (KOREA)
	BEAM: Debuncher Ring A Search for Neutrino Oscillations using the Fermilab Debuncher.		
	+-----+		
	Request	14 Jan, 92	Unspecified
	Withdrawn	17 Jan, 96	

861	ANTIPROTON DECAY #T861 BEAM: Accumulator Ring Test of Backgrounds for an Antiproton Decay Search Experiment at the Antiproton Accumulator	Steve Gear	UNIV. OF CALIFORNIA, LOS ANGELES FERMILAB PENNSYLVANIA STATE UNIVERSITY
	Request	10 Feb, 92	24 Hours
	Approval	16 Apr, 92	
	Completed	29 Oct, 92	
862	ANTI-HYDROGEN DETECTION #862 BEAM: Accumulator Ring Detection of Relativistic Anti-Hydrogen Atoms produced by Pair Production with Positron Capture	David C. Christian	UNIV. OF CALIFORNIA, IRVINE FERMILAB
	Request	27 Aug, 92	Unspecified
	Approval	4 Mar, 93	
	In Progress	10 Nov, 96	
	Data Analysis	18 Sep, 97	
	Completed	1 Mar, 99	
863	NUCLEON SPIN #863 BEAM: Meson Area - Polarized Proton Beam Nucleon Spin Structure Studies with Polarized Proton and Antiproton Beams	Aldo Penzo	ARGONNE NATIONAL LABORATORY CEN-SACLAY (FRANCE) CNRS, MARSEILLE (FRANCE) UNIVERSITY OF IOWA KYOTO SANGYO UNIVERSITY (JAPAN) KYOTO UNIVERSITY (JAPAN) KYOTO UNIV. OF EDUCATION (JAPAN) LAPP, D'ANNECY-LE-VIEUX (FRANCE) INFN, MESSINA (ITALY) NEW MEXICO STATE UNIVERSITY UN. OF OCCUP. & ENV. HEALTH (JAPAN) OKAYAMA UNIVERSITY (JAPAN) OSAKA CITY UNIVERSITY (JAPAN) IHEP, PROTIVNO (SERPUKHOV) (RUSSIA) RICE UNIVERSITY UNIVERSITY DI TRIESTE (ITALY)
	Request	31 Aug, 92	7 Months
	Rejected	7 Dec, 92	
864	MAXIMUM ACCEPTANCE DETECTOR #T864 BEAM: Collision Area (C-0) Maximum Acceptance Detector for the Fermilab Collider (MAX)	James D. Bjorken and Cyrus C. Taylor	CASE WESTERN RESERVE UNIVERSITY DUKE UNIVERSITY FERMILAB LOS ALAMOS NATIONAL LABORATORY UNIVERSITY OF MICHIGAN - ANN ARBOR SLAC VIRGINIA TECH
	Request	1 Sep, 92	Unspecified
	Approval	24 May, 93	Unspecified
	Completed	20 Dec, 95	
865	CHARM AND BEAUTY DECAYS #865 BEAM: Meson Area - East High-Sensitivity Study of Charm and Beauty Decays.	Daniel M. Kaplan	ABILENE CHRISTIAN UNIVERSITY UNIV. OF CALIFORNIA, LOS ANGELES CEN-SACLAY (FRANCE) CERN (SWITZERLAND) CINVESTAV-IPN (MEXICO) FERMILAB ILLINOIS INSTITUTE OF TECHNOLOGY IOWA STATE UNIVERSITY UNIVERSITE DE LAUSANNE NORTHERN ILLINOIS UNIVERSITY UNIVERSITY OF SOUTH CAROLINA UNIVERSITY OF TEXAS AT DALLAS
	Request	1 Sep, 92	Unspecified
	Withdrawn	4 Feb, 94	
866	ANTI (U-QUARK)/ANTI (D-QUARK) DIST#866 BEAM: Meson Area - East Measurement of x distribution of the ratio of anti(u-quark) to anti(d-quark) in the proton	Michael J. Leitch	ABILENE CHRISTIAN UNIVERSITY ARGONNE NATIONAL LABORATORY FERMILAB GEORGIA STATE UNIVERSITY ILLINOIS INSTITUTE OF TECHNOLOGY LOS ALAMOS NATIONAL LABORATORY LOUISIANA STATE UNIVERSITY NEW MEXICO STATE UNIVERSITY OAK RIDGE NATIONAL LABORATORY TEXAS A&M UNIVERSITY VALPARAISO UNIVERSITY
	Request	2 Sep, 92	Unspecified
	Approval	7 Dec, 92	Unspecified
	In Progress	14 Sep, 96	
	Data Analysis	6 Aug, 97	
	Completed	6 Dec, 01	
867	HIDDEN CHARM AND BEAUTY #867 BEAM: Proton Area - West A Proposal to Continue the Study of Hidden Charm and Beauty States by Triggering on High Transverse Momentum Single Muons and High Mass Dimuons in 800 GeV/c pN Interactions	Bradley B. Cox	UNIVERSITY OF SOUTH ALABAMA UNIV. OF CALIFORNIA, BERKELEY UNIV. OF CALIFORNIA, LOS ANGELES FERMILAB UNIVERSITY OF HOUSTON JINR, DUBNA (RUSSIA) UNIVERSITY OF LECCE (ITALY) MCGILL UNIVERSITY (CANADA) ACADEMY OF SCI. OF BSSR (BYELARUS) NANJING UNIVERSITY (PRC) NORTHWESTERN UNIVERSITY UNIVERSITY OF PAVIA (ITALY) UNIVERSITY OF PENNSYLVANIA PRAIRIE VIEW A&M UNIVERSITY SHANDONG UNIVERSITY (PRC) IHEP, TBILISI STATE UNIV (GEORGIA) VANIER COLLEGE (CANADA) UNIVERSITY OF VIRGINIA UNIVERSITY OF WISCONSIN - MADISON YEREVAN PHYSICS INST. (ARMENIA)
	Request	3 Sep, 92	Unspecified
	Rejected	28 Feb, 94	
868	ANTIPROTON DECAY #868 BEAM: Accumulator Ring Proposal to Search for Antiproton Decay at the Fermilab Antiproton Accumulator	Steve Gear	UNIV. OF CALIFORNIA, LOS ANGELES FERMILAB UNIVERSITY OF MICHIGAN - ANN ARBOR UNIVERSITY OF NEBRASKA PENNSYLVANIA STATE UNIVERSITY
	Request	24 Sep, 92	Unspecified
	Approval	4 Mar, 93	
	Data Analysis	24 Jul, 95	
	Completed	1 Mar, 01	

869	GEM DETECTOR AT THE SSC #869 BEAM: Meson Area - West Testing of Components for the GEM Detector at the Superconducting Super Collider Laboratory: A Proposal to the Fermi National Accelerator Laboratory	Barry C. Barish and William J. Willis	FERMILAB SSC LABORATORY
	Request	11 Nov, 92	Unspecified
	Withdrawn	4 Jan, 94	
870	PROTOTYPE DETECTORS FOR THE SDC #870 BEAM: Meson Area - Polarized Proton Beam PROTOTYPE DETECTORS FOR THE SDC #870	George H. Trilling	FERMILAB LAWRENCE BERKELEY LABORATORY SSC LABORATORY
	Request	1 Jan, 93	Unspecified
	Withdrawn	4 Jan, 94	
871	CP VIOLATION #871 BEAM: Meson Area - Center A Search for CP Violation in the Decays of Cascade minus / Anti-Cascade plus and Neutral Lambda / Neutral Anti-Lambda Hyperons	Kam-Biu Luk and Edmond Craig Dukes	IHEP, ACADEMIA SINICA (TAIWAN) UNIVERSITY OF SOUTH ALABAMA UNIV. OF CALIFORNIA, BERKELEY FERMILAB UNIVERSITY OF GUANAJUATO (MEXICO) ILLINOIS INSTITUTE OF TECHNOLOGY UNIVERSITE DE LAUSANNE LAWRENCE BERKELEY LABORATORY UNIVERSITY OF MICHIGAN - ANN ARBOR UNIVERSITY OF VIRGINIA
	Request	21 Mar, 93	Unspecified
	Approval	29 Jun, 94	Unspecified Stage I approval
	In Progress	20 Feb, 97	
	Data Analysis	21 Jan, 00	
872	TAU NEUTRINO #872 BEAM: Proton Area - West BEAM DUMP #872	Vittorio Paolone and George S. Tzanakos	AICHI UNIV. OF EDUCATION (JAPAN) UNIVERSITY OF ATHENS (GREECE) UNIV. OF CALIFORNIA, DAVIS CHANGWON NATIONAL UNIV. (KOREA) CHONNAM NATIONAL UNIVERSITY (KOREA) FERMILAB COLLEGE DE FRANCE (FRANCE) GYEONGSANG NATIONAL UNIV. (KOREA) KANSAS STATE UNIVERSITY KOBE UNIVERSITY (JAPAN) KON-KUK UNIVERSITY (KOREA) KOREAN NTNL.UN.OF EDUCATION (KOREA) UNIVERSITY OF MINNESOTA NAGOYA UNIVERSITY (JAPAN) OSAKA SCIENCE EDUC. INST. (JAPAN) UNIVERSITY OF SOUTH CAROLINA TOHO UNIVERSITY (JAPAN) TUFTS UNIVERSITY UTSUNOMIYA UNIVERSITY (JAPAN)
	Request	26 Mar, 93	Unspecified
	Approval	29 Jun, 94	Unspecified Stage I approval granted. 10 to the 18th protons-on-target minimum.
	In Progress	20 Feb, 97	
	Data Analysis	3 Sep, 97	
873	BOOSTER NEUTRINOS #873 BEAM: Booster Accelerator Letter of Intent to Perform a Neutrino Experiment using the Fermilab 8 GEV Booster	Fred J. Federspiel and H. White	LOS ALAMOS NATIONAL LABORATORY
	Request	21 Oct, 94	Unspecified
	Unconsidered	21 Oct, 94	
	Inactive	3 Feb, 98	
874	CHARGED PION LIFETIME #874 BEAM: Meson Area - West Precision Measurement of the Lifetime of Charged Pions	Steve Geer	DUKE UNIVERSITY FERMILAB UNIVERSITY OF NEBRASKA ROCKEFELLER UNIVERSITY
	Request	9 Nov, 94	Unspecified
	Withdrawn	16 Dec, 96	
875	NEUTRINO OSCILLATIONS #875 BEAM: Main Injector - NuMI A Long-baseline Neutrino Oscillation Experiment at Fermilab	Robert K. Plunkett and Stanley G. Wojcicki	ARGONNE NATIONAL LABORATORY UNIVERSITY OF ATHENS (GREECE) BENEDICTINE UNIVERSITY BROOKHAVEN NATIONAL LABORATORY CALIFORNIA INSTITUTE OF TECHNOLOGY UNIVERSITY OF CAMBRIDGE (ENGLAND) UNIV. ESTADUAL DE CAMPINAS (BRAZIL) FERMILAB COLLEGE DE FRANCE (FRANCE) HARVARD UNIVERSITY ILLINOIS INSTITUTE OF TECHNOLOGY INDIANA UNIVERSITY LEBEDEV PHYSICAL INST. (RUSSIA) UNIVERSITY COLLEGE LONDON (ENGLAND) UNIVERSITY OF MINNESOTA - DULUTH UNIVERSITY OF MINNESOTA ITEP, MOSCOW (RUSSIA) UNIVERSITY OF OXFORD (ENGLAND) UNIVERSITY OF PITTSBURGH IHEP, PROTIVNO (SERPUKHOV) (RUSSIA) RUTHERFORD-APPLETON LABS. (ENGLAND) UNIVERSITE DE SAO PAULO (BRAZIL) UNIVERSITY OF SOUTH CAROLINA STANFORD UNIVERSITY SUSSEX UNIVERSITY (ENGLAND) TEXAS A&M UNIVERSITY UNIVERSITY OF TEXAS AT AUSTIN TUFTS UNIVERSITY WESTERN WASHINGTON UNIVERSITY COLLEGE OF WILLIAM AND MARY UNIVERSITY OF WISCONSIN - MADISON
	Request	9 Feb, 95	Unspecified
	Approval	2 May, 95	
	Unscheduled	2 May, 95	
	Being Installed	1 Aug, 01	
	In Progress	28 Feb, 05	

876	CDF HARD DIFFRACTION STUDIES #876 BEAM: Collision Area (B-0) Proposal for Hard Diffraction Studies in CDF	Mike G. Albrow	IHEP, ACADEMIA SINICA (TAIWAN) ARGONNE NATIONAL LABORATORY UNIVERSITY OF BOLOGNA (ITALY) BRANDEIS UNIVERSITY UNIV. OF CALIFORNIA, LOS ANGELES CIPP (CANADA) UNIVERSITY OF CHICAGO DUKE UNIVERSITY FERMILAB INFN, FRASCATI (ITALY) HARVARD UNIVERSITY HIROSHIMA UNIVERSITY (JAPAN) UNIVERSITY OF ILLINOIS, CHAMPAIGN JOHNS HOPKINS UNIVERSITY KEK (JAPAN) LAWRENCE BERKELEY LABORATORY MASSACHUSETTS INST. OF TECHNOLOGY UNIVERSITY OF MICHIGAN - ANN ARBOR MICHIGAN STATE UNIVERSITY UNIVERSITY OF NEW MEXICO OSAKA CITY UNIVERSITY (JAPAN) UNIVERSITY OF PADOVA (ITALY) UNIVERSITY OF PENNSYLVANIA INFN, PISA (ITALY) UNIVERSITY OF PITTSBURGH PURDUE UNIVERSITY UNIVERSITY OF ROCHESTER ROCKEFELLER UNIVERSITY RUTGERS UNIVERSITY TEXAS A&M UNIVERSITY TEXAS TECH UNIVERSITY UNIVERSITY OF TSUKUBA (JAPAN) TUFTS UNIVERSITY WASEDA UNIVERSITY (JAPAN) UNIVERSITY OF WISCONSIN - MADISON YALE UNIVERSITY
	Request 17 Jan, 95 Unspecified Approval 3 Aug, 95 Data Analysis 20 Feb, 96 Completed 1 Feb, 04		
877	AXION SEARCH #877 BEAM: Beam Not Applicable Measurement of the Magnetically-Induced QED Birefringence of the Vacuum and an Improved Laboratory Search for Axions	Siu Au Lee	COLORADO STATE UNIVERSITY FERMILAB JOINT INST. FOR LAB. ASTROPHYSICS SSC LABORATORY
	Request 28 Mar, 95 Unspecified Unconsidered 28 Mar, 95 Rejected 14 Mar, 00		
878	SPIN STRUCTURE FUNCTION PHYSICS #878 BEAM: Main Injector Area Spin Structure Function Physics at Fermilab.	Joel M. Moss	LOS ALAMOS NATIONAL LABORATORY
	Request 7 Nov, 95 Unspecified Unconsidered 7 Nov, 95 Inactive 3 Feb, 98		
879	B PHYSICS TEST BEAM PROGRAM #879 BEAM: Meson Area - Test Beam A Test Beam Program for Future B Physics Experiments at Fermilab	Joel N. Butler and Walter Selove	CARNEGIE-MELLON UNIVERSITY FERMILAB UNIVERSITY OF PENNSYLVANIA SYRACUSE UNIVERSITY
	Request 16 Mar, 95 Unspecified Unconsidered 16 Mar, 95 Inactive 3 Feb, 98		
880	B PHYSICS TEST BEAM PROGRAM #T880 BEAM: Meson Area - Test Beam Proposal for Test Beam Running of the CLEO III RICH Detector	Sheldon L. Stone	CARNEGIE-MELLON UNIVERSITY FERMILAB UNIVERSITY OF MINNESOTA SYRACUSE UNIVERSITY WAYNE STATE UNIVERSITY
	Request 16 Mar, 95 Unspecified Unconsidered 16 Mar, 95 Approval 28 Feb, 96 Data Analysis 19 May, 97 Completed 1 Mar, 01		
881	AUGER PROJECT R&D #881 BEAM: Beam Not Applicable A Request for Fermilab R&D Support for the Pierre Auger Project.	Paul M. Mantsch	FERMILAB
	Request 6 Nov, 95 Unspecified Approval 8 Oct, 96 Unscheduled 8 Oct, 96 In Progress 1 Jan, 02		
882	SEARCH FOR LOW MASS MONOPOLES #882 BEAM: Beam Not Applicable A Search for Low Mass Monopoles	George R. Kalbfleisch	UNIVERSITY OF OKLAHOMA
	Request 15 Aug, 95 Unspecified Approval 23 Jul, 96 Unscheduled 23 Jul, 96 In Progress 23 Sep, 96 Data Analysis 1 Mar, 01 Completed 1 Feb, 04		
883	COSMIC RAY CALORIMETER CALIB. #T883 BEAM: Meson Area - West Calibration of Cosmic Ray "Thin Ionization Calorimeter"	James H. Adams	LEBDEV PHYSICAL INST. (RUSSIA) MOSCOW STATE UNIVERSITY (RUSSIA) NAVAL RESEARCH LABORATORY
	Request 26 Oct, 95 Unconsidered 26 Oct, 95 Approval 16 Jul, 97 Data Analysis 6 Aug, 97 Completed 1 Mar, 01		

884	COSMIC RAY DETECTOR TEST #884 BEAM: Meson Area - West A proposal for a Beam Test of the Advanced Thin Ionization Calorimeter Detector +-----+ Request 1 Feb, 96 Unconsidered 1 Feb, 96 Inactive 15 Mar, 99	Sun Kee Kim	LOUISIANA STATE UNIVERSITY UNIVERSITY OF MARYLAND MAX-PLANCK INSTITUTE (GERMANY) MOSCOW STATE UNIVERSITY (RUSSIA) NAVAL RESEARCH LABORATORY SEOUL NATIONAL UNIVERSITY (KOREA) SOUTHERN UNIVERSITY, BATON ROUGE
885	SLOAN DIGITAL SKY SURVEY #885 BEAM: Beam Not Applicable SLOAN DIGITAL SKY SURVEY +-----+ Approval 9 Feb, 96 Unscheduled 9 Feb, 96 In Progress 1 Jun, 98 Data Analysis 30 Jun, 05	Stephen M. Kent	FERMILAB
886	EXPERIMENTS AT THE A0 PHOTOINJECTOR #886 BEAM: A0 Facility Compton Scattering X-Ray Experiments at the Fermilab Electron Source Facility +-----+ Request 14 May, 96 Approval 8 Oct, 96 Unscheduled 8 Oct, 96 In Progress 1 Mar, 99	Helen T. Edwards and Raymond P. Filler	UNIV. OF CALIFORNIA, LOS ANGELES UNIVERSITY OF CHICAGO DESY (GERMANY) FERMILAB UNIVERSITY OF GEORGIA UNIVERSITY OF ILLINOIS, CHAMPAIGN MICHIGAN STATE UNIVERSITY INFN, MILANO (ITALY) NORTHERN ILLINOIS UNIVERSITY UNIVERSITY OF ROCHESTER
887	PET ACCELERATOR #887 BEAM: Beam Not Applicable A RFQ Linear Accelerator for PET Isotope Production +-----+ Request 21 Jun, 95 Approval 21 Jun, 95 Unscheduled 21 Jun, 95 Completed 31 Aug, 98	Ralph Pasquinelli	FERMILAB
888	P-BAR+NUCLEI STUDIES #888 BEAM: Main Injector Area P-Bar + A Studies of the Nuclear Equation-of-State +-----+ Request 15 Jul, 96 Unconsidered 15 Jul, 96 Withdrawn 12 Dec, 02	Vic. E. Viola	INDIANA UNIVERSITY
889	NEUTRINOS AT THE BOOSTER #889 BEAM: Booster Accelerator Letter of Intent to Study Neutrino Oscillations Using the Fermilab Booster Beam +-----+ Request 6 Aug, 96 Unconsidered 6 Aug, 96 Inactive 15 Mar, 99	Alexander Abashian	VIRGINIA TECH
890	PLASMA WAKE-FIELD ACCELERATOR #890 BEAM: A0 Facility Advanced Accelerator Test at the Fermilab Electron Source Facility +-----+ Request 25 Sep, 96 Approval 8 Oct, 96 Unscheduled 8 Oct, 96 Setup in a Year 1 Mar, 99 In Progress 1 Jan, 00 Data Analysis 7 Jul, 02 Completed 1 Feb, 04	James R. Rosenzweig	UNIV. OF CALIFORNIA, LOS ANGELES FERMILAB
891	CDMS #891 BEAM: Beam Not Applicable The Cryogenic Dark Matter Search (CDMS) +-----+ Request 4 Mar, 96 Approval 4 Mar, 96 Unscheduled 4 Mar, 96 In Progress 1 Jan, 98	Dan Bauer	FERMILAB
892	CMS AT FERMILAB #892 BEAM: Beam Not Applicable The U.S. Compact Muon Solenoid (CMS) Collaboration at Fermilab +-----+ Request 8 Oct, 96 Approval 8 Oct, 96 Unscheduled 8 Oct, 96 Setup Within Year 1 Feb, 07	Joel N. Butler	FERMILAB
893	LHC ACCELERATOR #893 BEAM: Beam Not Applicable Design and Construction of Interaction Regions at the CERN Large Hadron Collider (LHC) +-----+ Request 8 Oct, 96 Approval 8 Oct, 96 Unscheduled 8 Oct, 96 Completed 1 Nov, 06	James S. Kerby	FERMILAB
894	CPT TEST #894 BEAM: Main Injector Area An Experiment Studying K1 - Ks Interference to Test CPT Conservation at the Planck Scale +-----+ Request 7 Oct, 96 Unconsidered 7 Oct, 96 Rejected 6 Jul, 99	Gordon B. Thomson	RUTGERS UNIVERSITY TRIUMF (CANADA)

895	PIXEL DETECTOR TEST #895 BEAM: Meson Area - Test Pixel Detector Test +-----+ Request 17 Mar, 97 Withdrawn 28 Jan, 98	Simon Kwan	FERMILAB
896	RADIO COHERENCE TEST #896 BEAM: Main Injector Area Test of the Principle of Radio Coherence +-----+ Request 4 Nov, 96 Unconsidered 4 Nov, 96	David Besson	UNIVERSITY OF KANSAS
897	BTeV R&D #897 BEAM: Collision Area (C-0) BTeV: A Heavy Quark Program at C0 +-----+ Request 18 May, 97 Unconsidered 18 May, 97 Approval 13 Jan, 98 Unscheduled 13 Jan, 98 In Progress 15 Jun, 99 Data Analysis 21 Jul, 00 Completed 1 Jan, 02	Joel N. Butler and Sheldon Stone	CARNEGIE-MELLON UNIVERSITY UNIVERSITY OF COLORADO AT BOULDER FERMILAB UNIVERSITY OF FLORIDA ILLINOIS INSTITUTE OF TECHNOLOGY UNIVERSITY OF ILLINOIS, CHAMPAIGN INDIANA UNIVERSITY UNIVERSITY OF IOWA INFN, MILANO (ITALY) UNIVERSITY OF MINNESOTA NANJING UNIVERSITY (PRC) NEW MEXICO STATE UNIVERSITY OHIO STATE UNIVERSITY INFN, PAVIA (ITALY) UNIVERSITY OF PENNSYLVANIA IHEP, PROTIVNO (SERPUKHOV) (RUSSIA) UNIV. OF PUERTO RICO - MAYAGUEZ UNIV. OF SCI & TECH., HEFEI (PRC) SHANDONG UNIVERSITY (PRC) SYRACUSE UNIVERSITY UNIVERSITY OF TENNESSEE, KNOXVILLE TUFTS UNIVERSITY VANDERBILT UNIVERSITY UNIVERSITY OF WISCONSIN - MADISON YALE UNIVERSITY YORK UNIVERSITY
898	MINIBOONE #898 BEAM: Booster Accelerator An Experiment to Measure $\nu\text{-}\mu\text{-}\nu$ Oscillations and $\nu\text{-}\mu$ Disappearance at the Fermilab Booster +-----+ Request 16 May, 97 Unconsidered 16 May, 97 Approval 4 Jun, 98 Unscheduled 4 Jun, 98 Setup in a Year 1 Mar, 01 Being Installed 1 Jan, 02 In Progress 1 Sep, 02 Data Analysis 23 Jan, 06	Janet M. Conrad and William Charles Louis	UNIVERSITY OF ALABAMA BUCKNELL UNIVERSITY UNIVERSITY OF CINCINNATI UNIVERSITY OF COLORADO AT BOULDER COLUMBIA UNIVERSITY EMBRY RIDDLE AERONAUTICAL UNIV. FERMILAB INDIANA UNIVERSITY LOS ALAMOS NATIONAL LABORATORY LOUISIANA STATE UNIVERSITY UNIVERSITY OF MICHIGAN - ANN ARBOR PRINCETON UNIVERSITY ST. MARY'S UNIVERSITY OF MINNESOTA WESTERN ILLINOIS UNIVERSITY YALE UNIVERSITY
899	PARTICLE PRODUCTION #899 BEAM: Collision Area (C-0) Particle Production at Zero Degrees from the +-----+ Request 31 May, 97 Rejected 23 Oct, 97	Michael Longo	CASE WESTERN RESERVE UNIVERSITY LOUISIANA STATE UNIVERSITY UNIVERSITY OF MICHIGAN FERMILAB UNIVERSITY OF TENNESSEE

900	D-0 FORWARD PROTON DETECTOR #900 BEAM: Collision Area (D-0) A Forward Proton Detector at D-0 +-----+ Request 17 Sep, 97 Unconsidered 17 Sep, 97 Approval 29 May, 98 Unscheduled 29 May, 98 Setup in a Year 1 Mar, 99 In Progress 1 Mar, 01 Data Analysis 27 Feb, 06	Gerald Blazey and Terry Wyatt	INST. OF PHYS. ACADEMY OF SCI (CZECH) UNIVERSITY OF ALBERTA (CANADA) UNIVERSIDAD DE LOS ANDES (COLOMBIA) UNIVERSITY OF ARIZONA IHEP, BEIJING (PRC) UNIVERSITY OF BONN (GERMANY) BOSTON UNIVERSITY BROOKHAVEN NATIONAL LABORATORY BROWN UNIVERSITY UNIV. DE BUENOS AIRES (ARGENTINA) CALIFORNIA STATE UNIVERSITY UNIV. OF CALIFORNIA, RIVERSIDE CBPF (BRAZIL) CEA-SACLAY (FRANCE) CPM, MARSEILLE (FRANCE) CHARLES UNIVERSITY (CZECH) CINVESTAV-IPN (MEXICO) LPN, UNIV. DE CLERMONT (FRANCE) COLUMBIA UNIVERSITY CZECH TECHNICAL UNIVERSITY (CZECH) DELHI UNIVERSITY (INDIA) UNIVERSITY COLLEGE DUBLIN (IRELAND) FERMILAB FLORIDA STATE UNIVERSITY FREIBURG UNIVERSITY (GERMANY) HO CHI MINH CITY INS PHY (VIET NAM) UNIV. OF ILLINOIS, CHICAGO CIRCLE IMPERIAL COLLEGE (ENGLAND) INDIANA UNIVERSITY INS RECHERCHES SUBATOMIQUE (FRANCE) ISN (GRENOBLE, FRANCE) IPNL (FRANCE) IOWA STATE UNIVERSITY JINR, DUBNA (RUSSIA) KANSAS STATE UNIVERSITY UNIVERSITY OF KANSAS KOREA UNIVERSITY, SEOUL (KOREA) LAL, ORSAY (FRANCE) LANCASTER UNIVERSITY (ENGLAND) LANGSTON UNIVERSITY LAWRENCE BERKELEY NATIONAL LAB. LOUISIANA TECH UNIVERSITY LPNHE, UN. OF P & M CURIE (FRANCE) LUDWIG MAXIMILIANS UNIV. (GERMANY) LUND, RIT, STOCKHOLM, UPPSALA (SWEDEN) MAINZ UNIVERSITY (GERMANY) UNIVERSITY OF MANCHESTER (ENGLAND) UNIVERSITY OF MARYLAND UNIVERSITY OF MICHIGAN - ANN ARBOR MICHIGAN STATE UNIVERSITY UNIVERSITY OF MISSISSIPPI MOSCOW STATE UNIVERSITY (RUSSIA) ITEP, MOSCOW (RUSSIA) UNIVERSITY OF NEBRASKA - LINCOLN SUNY AT BUFFALO SUNY AT STONY BROOK UN OF NIJMEGEN/NIKHEF (NETHERLANDS) NIKHEF&U OF AMSTERDAM (NETHERLANDS) NORTHEASTERN UNIVERSITY NORTHERN ILLINOIS UNIVERSITY NORTHWESTERN UNIVERSITY UNIVERSITY OF NOTRE DAME OKLAHOMA STATE UNIVERSITY UNIVERSITY OF OKLAHOMA PANJAB UNIVERSITY (INDIA) UNESP (BRAZIL) PNPI, ST. PETERSBURG (RUSSIA) PRINCETON UNIVERSITY IHEP, PROTIVNO (SERPUKHOV) (RUSSIA) RICE UNIVERSITY UN. ESTADO RIO DE JANEIRO (BRAZIL) UNIVERSITY OF ROCHESTER RWTH, AACHEN (GERMANY) UN. SAN FRANCISCO DE QUITO (ECUADOR) UNIV. OF SCI. & TECH., HEFEI (PRC) SIMON FRASER UNIVERSITY (CANADA) SOUTHERN METHODIST UNIVERSITY SUNG KYUN KWAN UNIVERSITY (KOREA) TATA INSTITUTE (INDIA) UNIVERSITY OF TEXAS AT ARLINGTON UNIVERSITY OF ZURICH (SWITZERLAND) UNIVERSITY OF VIRGINIA UNIVERSITY OF WASHINGTON UNIVERSITY OF WUPPERTAL (GERMANY)
901	RECYCLER ELECTRON COOLING #901 BEAM: Beam Not Applicable Recycler Medium Energy Electron Cooling Experiment +-----+ Request 14 Nov, 97 Approval 14 Nov, 97 Unscheduled 14 Nov, 97 Setup in a Year 1 Jan, 00 In Progress 1 Mar, 01 Completed 31 May, 04	Sergei Nagaitsev	FERMILAB INDIANA UNIVERSITY JINR, DUBNA (RUSSIA) UNIVERSITY OF ROCHESTER

902	EXOTIC ATOMS #902 BEAM: Main Injector Area Particle Mass Measurement and Strong Interaction Studies with Exotic Atoms Using X-Ray Crystal Spectrometer +-----+ Request 24 Sep, 97 Unconsidered 24 Sep, 97 Deferred 29 Nov, 01	Yuri M. Ivanov	PNPI, ST. PETERSBURG (RUSSIA)
903	TEST FOR ANTIHYDROGEN SPECTROSCOPY#903 BEAM: Booster Accelerator A Test Experiment at the Fermilab Booster to Study the Feasibility of Fast Antihydrogen Spectroscopy +-----+ Request 20 Mar, 98 Unconsidered 20 Mar, 98 Withdrawn 18 Dec, 02	Mark A. Mandelkern	UNIV. OF CALIFORNIA, IRVINE FERMILAB UNIVERSITY OF ROCHESTER
904	MUON COLLIDING R&D #904 BEAM: Unspecified Beam Ionization Cooling Research and Development Program for a High Luminosity Muon Collider +-----+ Request 15 Apr, 98 Unconsidered 15 Apr, 98	Steve Geer	CEBAF - THOMAS JEFFERSON LAB. ARGONNE NATIONAL LABORATORY BROOKHAVEN NATIONAL LABORATORY BUDKER INS.NUCLEAR PHYSICS (RUSSIA) UNIV. OF CALIFORNIA, BERKELEY UNIV. OF CALIFORNIA, LOS ANGELES FAIRFIELD UNIVERSITY FERMILAB INDIANA UNIVERSITY UNIVERSITY OF IOWA JOSEPH HENRY LABORATORIES LAWRENCE BERKELEY NTL. LABORATORY UNIVERSITY OF MISSISSIPPI ROCKEFELLER UNIVERSITY
905	CKM R&D #905 BEAM: Main Injector Area A Proposal for a Precision Measurement of the Decay K^+ to $\pi^+\nu$ -nubar and Other Rare K^+ Processes at Fermilab Using the Main Injector +-----+ Request 15 Apr, 98 Unconsidered 15 Apr, 98 Approval 6 Jul, 99 In Progress 6 Jul, 99 Completed 28 Jun, 01	Peter S. Cooper	BROOKHAVEN NATIONAL LABORATORY FERMILAB UNIVERSITY OF MICHIGAN - ANN ARBOR IHEP, PROTIVNO (SERPUKHOV) (RUSSIA) UN.AUTO.DE SAN LUIS POTOSI (MEXICO) UNIVERSITY OF TEXAS AT AUSTIN UNIVERSITY OF VIRGINIA
906	ANTI (D-QUARK)/ANTI (U-QUARK) DIST #906 BEAM: Main Injector - Unspecified Letter of Intent for Drell-Yan Measurements of Nucleon and Nuclear Structure with The FNAL Main Injector +-----+ Request 15 Apr, 98 Unconsidered 2 Apr, 01 Approval 26 Nov, 01 Unscheduled 26 Nov, 01	Donald Geesaman and Paul E. Reimer	ABILENE CHRISTIAN UNIVERSITY ARGONNE NATIONAL LABORATORY CEBAF - THOMAS JEFFERSON LAB. UNIVERSITY OF COLORADO AT BOULDER FERMILAB UNIVERSITY OF ILLINOIS, CHAMPAIGN LOS ALAMOS NATIONAL LABORATORY UNIVERSITY OF MARYLAND RUTGERS UNIVERSITY TEXAS A&M UNIVERSITY VALPARAISO UNIVERSITY
907	PARTICLE PRODUCTION #907 BEAM: Main Injector - M Center Proposal to Measure Particle Production in the Meson Area Using Main Injector Primary and Secondary Beams +-----+ Request 21 Jul, 97 Unconsidered 15 Apr, 98 Deferred 8 Nov, 00 Approval 8 Nov, 01 Unscheduled 8 Nov, 01 Being Installed 1 Dec, 02 In Progress 1 Feb, 04	Rajendran Raja	BROOKHAVEN NATIONAL LABORATORY UNIVERSITY OF COLORADO AT BOULDER ELMHURST COLLEGE ENRICO FERMI INSTITUTE FERMILAB HARVARD UNIVERSITY ILLINOIS INSTITUTE OF TECHNOLOGY INDIANA UNIVERSITY UNIVERSITY OF IOWA LAWRENCE LIVERMORE NTL. LABORATORY UNIVERSITY OF MICHIGAN - ANN ARBOR PURDUE UNIVERSITY UNIVERSITY OF SOUTH CAROLINA UNIVERSITY OF VIRGINIA

Proposal #	Title	PIs	Status	Start Date	End Date	Stage	Institutions
908	D-0 SILICON TRACK TRIGGER #908	Dmitri S. Denisov and Terry Wyatt	Request	21 Sep, 98			INST. OF PHYS. ACADEMY OF SCI (CZECH)
	BEAM: Collision Area (D-0)		Unconsidered	21 Sep, 98			UNIVERSITY OF ALBERTA (CANADA)
	A Silicon Track Trigger for the D0 Experiment in Run II		Approval	29 Jan, 99		Stage I	UNIVERSIDAD DE LOS ANDES (COLOMBIA)
				15 Nov, 99		Stage II	UNIVERSITY OF ARIZONA
				1 Jan, 00			UNIVERSITY OF BONN (GERMANY)
				1 Mar, 01			BOSTON UNIVERSITY
							BROOKHAVEN NATIONAL LABORATORY
							BROWN UNIVERSITY
							UNIV. DE BUENOS AIRES (ARGENTINA)
							CALIFORNIA STATE UNIVERSITY
							UNIV. OF CALIFORNIA, RIVERSIDE
							CBPF (BRAZIL)
							CEA-SACLAY (FRANCE)
							CPPM, MARSEILLE (FRANCE)
							CHARLES UNIVERSITY (CZECH)
							CINVESTAV-IPN (MEXICO)
							LPN, UNIV. DE CLERMONT (FRANCE)
							COLUMBIA UNIVERSITY
							CZECH TECHNICAL UNIVERSITY (CZECH)
							DELHI UNIVERSITY (INDIA)
							UNIVERSITY COLLEGE DUBLIN (IRELAND)
							FERMILAB
							FLORIDA STATE UNIVERSITY
							FREIBURG UNIVERSITY (GERMANY)
							UNIV. OF ILLINOIS, CHICAGO CIRCLE
							IMPERIAL COLLEGE (ENGLAND)
							INDIANA UNIVERSITY
							INS RECHERCHES SUBATOMIQUE (FRANCE)
							ISN (GRENOBLE, FRANCE)
							IPNL (FRANCE)
							IOWA STATE UNIVERSITY
							JINR, DUBNA (RUSSIA)
							KANSAS STATE UNIVERSITY
							UNIVERSITY OF KANSAS
							KOREA UNIVERSITY, SEOUL (KOREA)
							LAL, ORSAY (FRANCE)
							LANCASTER UNIVERSITY (ENGLAND)
							LANGSTON UNIVERSITY
							LAWRENCE BERKELEY NATIONAL LAB.
							LOUISIANA TECH UNIVERSITY
							LPNHE, UN. OF P & M CURIE (FRANCE)
							LUDWIG MAXIMILIANS UNIV. (GERMANY)
							LUND, RIT, STOCKHOLM, UPPSALA (SWEDEN)
							MAINZ UNIVERSITY (GERMANY)
							UNIVERSITY OF MANCHESTER (ENGLAND)
							UNIVERSITY OF MARYLAND
							UNIVERSITY OF MICHIGAN - ANN ARBOR
							MICHIGAN STATE UNIVERSITY
							UNIVERSITY OF MISSISSIPPI
							MOSCOW STATE UNIVERSITY (RUSSIA)
							ITEP, MOSCOW (RUSSIA)
							UNIVERSITY OF NEBRASKA - LINCOLN
							SUNY AT BUFFALO
							SUNY AT STONY BROOK
							UN OF NIJMEGEN/NIKHEF (NETHERLANDS)
							NIKHEF&U OF AMSTERDAM (NETHERLANDS)
							NORTHEASTERN UNIVERSITY
							NORTHERN ILLINOIS UNIVERSITY
							NORTHWESTERN UNIVERSITY
							UNIVERSITY OF NOTRE DAME
							OKLAHOMA STATE UNIVERSITY
							UNIVERSITY OF OKLAHOMA
							PANJAB UNIVERSITY (INDIA)
							UNESP (BRAZIL)
							PNPI, ST. PETERSBURG (RUSSIA)
							PRINCETON UNIVERSITY
							PURDUE UNIVERSITY - CALUMET
							IHEP, PROTIVNO (SERPUKHOV) (RUSSIA)
							RICE UNIVERSITY
							UN. ESTADO RIO DE JANEIRO (BRAZIL)
							UNIVERSITY OF ROCHESTER
							RWTH, AACHEN (GERMANY)
							UN. SAN FRANCISCO DE QUITO (ECUADOR)
							UNIV. OF SCI. & TECH., HEFEI (PRC)
							SIMON FRASER UNIVERSITY (CANADA)
							SOUTHERN METHODIST UNIVERSITY
							SUNG KYUN KWAN UNIVERSITY (KOREA)
							TATA INSTITUTE (INDIA)
							UNIVERSITY OF TEXAS AT ARLINGTON
							UNIVERSITY OF VIRGINIA
							UNIVERSITY OF WASHINGTON
							UNIVERSITY OF WUPPERTAL (GERMANY)

909	CDF INNER SILICON AND TOF #909 BEAM: Collision Area (B-0) Proposal for Enhancement of the CDF II Detector: An Inner Silicon Layer and a Time of Flight Detector +-----+	Jacobo Konigsberg and Robert Roser	IHEP, ACADEMIA SINICA (TAIWAN) ARGONNE NATIONAL LABORATORY UNIVERSITY OF BARCELONA (SPAIN) BAYLOR UNIVERSITY UNIVERSITY OF BOLOGNA (ITALY) BRANDEIS UNIVERSITY UNIV. OF CALIFORNIA, DAVIS UNIV. OF CALIFORNIA, LOS ANGELES UNIV. OF CALIFORNIA, SAN DIEGO UNIV. OF CALIFORNIA, SANTA BARBARA UNIVERSITY OF CANTABRIA (SPAIN) CARNEGIE-MELLON UNIVERSITY UNIVERSITY OF CHICAGO CIEMAT, MADRID, SPAIN (SPAIN) COMENIUS UNIVERSITY (SLOVAKIA) DUKE UNIVERSITY FERMILAB UNIVERSITY OF FLORIDA INFN, FRASCATI (ITALY) UNIVERSITY OF GENEVA (SWITZERLAND) GLASGOW UNIVERSITY (SCOTLAND) HARVARD UNIVERSITY UNIVERSITY OF HELSINKI (FINLAND) UNIVERSITY OF ILLINOIS, CHAMPAIGN INFN, TRIESTE/UNIV DI UDINE (ITALY) IPP/MCGILL U/UN OF TORONTO(CANADA) JINR, DUBNA (RUSSIA) JOHNS HOPKINS UNIVERSITY UNIVERSITY OF KARLSRUHE (GERMANY) KOREA CENTER FOR HEP (KOREA) LAWRENCE BERKELEY NATIONAL LAB. UNIVERSITY OF LIVERPOOL (ENGLAND) UNIVERSITY COLLEGE LONDON(ENGLAND) LPNHE, UN. OF P & M CURIE (FRANCE) MASSACHUSETTS INST. OF TECHNOLOGY UNIVERSITY OF MICHIGAN - ANN ARBOR MICHIGAN STATE UNIVERSITY ITEP, MOSCOW (RUSSIA) UNIVERSITY OF NEW MEXICO NORTHWESTERN UNIVERSITY OHIO STATE UNIVERSITY OKAYAMA UNIVERSITY (JAPAN) OSAKA CITY UNIVERSITY (JAPAN) UNIVERSITY OF OXFORD (ENGLAND) UNIVERSITY OF PADOVA (ITALY) UNIVERSITY OF PENNSYLVANIA INFN, PISA (ITALY) UNIVERSITY OF PITTSBURGH PURDUE UNIVERSITY UNIVERSITY OF ROCHESTER ROCKEFELLER UNIVERSITY UNIVERSITY OF ROME (ITALY) RUTGERS UNIVERSITY TEXAS A&M UNIVERSITY UNIVERSITY OF TSUKUBA (JAPAN) TUFTS UNIVERSITY WASEDA UNIVERSITY (JAPAN) WAYNE STATE UNIVERSITY UNIVERSITY OF WISCONSIN - MADISON YALE UNIVERSITY
	Request 22 Sep, 98 Unconsidered 22 Sep, 98 Approval 29 Jan, 99 Stage I L00 & TOF 6 Jul, 99 Stage II L00 15 Nov, 99 Stage II TOF Unscheduled 29 Jan, 99 Setup in a Year 1 Jan, 00 In Progress 1 Mar, 01		
910	SPIN@FERMI #910 BEAM: Main Injector Area SPIN@FERMI Proposal - Analyzing Power A _{nin} High P-Transverse Squared Proton-Proton Elastic Scattering +-----+	Alan D. Krisch	INST.NUCL.RESEARCH,TROITSK(RUSSIA) JINR, DUBNA (RUSSIA) UNIVERSITY OF MICHIGAN - ANN ARBOR IHEP, PROTIVNO (SERPUKHOV) (RUSSIA) TRIUMF (CANADA) UNIVERSITY OF VIRGINIA
	Request 1 Aug, 98 Unconsidered 1 Aug, 98 Rejected 6 Jul, 99		
911	DIAMOND DETECTOR TEST #911 BEAM: Meson Area - Test Beam Fermilab Test Beam Proposal for Diamond Tracking Detectors +-----+	Robert L. Stone	FERMILAB OHIO STATE UNIVERSITY RUTGERS UNIVERSITY UNIVERSITY OF TORONTO (CANADA)
	Request 23 Nov, 98 Unconsidered 23 Nov, 98 Approval 29 Jul, 99 Completed 21 Jan, 00		
912	HADRON CALORIMETER TEST #912 BEAM: Meson Area - Test Beam Beam Test of High-Performance Hadron Calorimeter for Future Linear Colliders +-----+	Tohru Takeshita and Teruki Kamon	UNIV. OF CALIFORNIA, LOS ANGELES KEK (JAPAN) KOBE UNIVERSITY (JAPAN) KONAN UNIVERSITY (JAPAN) SHINSHU UNIVERSITY (JAPAN) TEXAS A&M UNIVERSITY UNIVERSITY OF TSUKUBA (JAPAN)
	Request 1 Feb, 99 Unconsidered 1 Feb, 99 Approval 3 Sep, 99 Completed 30 Sep, 99		
913	TRD TEST #913 BEAM: Meson Area - Test Beam Proposal for Calibration and Testing of a Transition Radiation Detector for Space Applications +-----+	Simon P. Swordy	UNIVERSITY OF CHICAGO
	Request 29 Dec, 98 Unconsidered 29 Dec, 98 Approval 19 Nov, 99 Completed 21 Jan, 00		

914	ANTIPROTON TRAPPING #914 BEAM: Beam Not Applicable A Magnetic Degrading Spectrometer for Trapping of Low-Energy Antiprotons at Fermilab +-----+ Request 28 Oct, 98 Rejected 6 Jul, 99	Gerald A. Smith	PENNSYLVANIA STATE UNIVERSITY SYNERGISTIC TECHNOLOGIES, INC.
915	MINOS EMULSION DETECTOR #915 BEAM: Main Injector Area The Hybrid Emulsion Detector for MINOS - R&D Proposal +-----+ Request 19 Apr, 99 Unconsidered 22 Jul, 99 Rejected 15 Nov, 99	Stanley G. Wojcicki	ARGONNE NATIONAL LABORATORY UNIVERSITY OF ATHENS (GREECE) IHEP, BEIJING (PRC) BROOKHAVEN NATIONAL LABORATORY CALIFORNIA INSTITUTE OF TECHNOLOGY UNIVERSITY OF CHICAGO ELMHURST COLLEGE FERMILAB HARVARD UNIVERSITY INDIANA UNIVERSITY JAMES MADISON UNIVERSITY JINR, DUBNA (RUSSIA) LAWRENCE LIVERMORE LABORATORY LEBEDEV PHYSICAL INST. (RUSSIA) UNIVERSITY COLLEGE LONDON (ENGLAND) UNIVERSITY OF MINNESOTA ITEP, MOSCOW (RUSSIA) NORTHWESTERN UNIVERSITY UNIVERSITY OF OXFORD (ENGLAND) UNIVERSITY OF PITTSBURGH IHEP, PROTVINO (SERPUKHOV) (RUSSIA) RUTHERFORD-APPLETON LABS. (ENGLAND) UNIVERSITY OF SOUTH CAROLINA STANFORD UNIVERSITY SUSSEX UNIVERSITY (ENGLAND) TEXAS A&M UNIVERSITY UNIVERSITY OF TEXAS AT AUSTIN TUFTS UNIVERSITY WESTERN WASHINGTON UNIVERSITY UNIVERSITY OF WISCONSIN - MADISON
916	CDF MINIPLUGS #916 BEAM: Collision Area (B-0) Further Studies in Hard Diffraction and Very Forward Physics +-----+ Request 4 Oct, 99 Deferred 15 Nov, 99 Being Installed 1 Mar, 01 In Progress 1 Mar, 01	Jacobo Konigsberg and Robert Roser	IHEP, ACADEMIA SINICA (TAIWAN) ARGONNE NATIONAL LABORATORY UNIVERSITY OF BARCELONA (SPAIN) BAYLOR UNIVERSITY UNIVERSITY OF BOLOGNA (ITALY) BRANDEIS UNIVERSITY UNIV. OF CALIFORNIA, DAVIS UNIV. OF CALIFORNIA, LOS ANGELES UNIV. OF CALIFORNIA, SAN DIEGO UNIV. OF CALIFORNIA, SANTA BARBARA UNIVERSITY OF CANTABRIA (SPAIN) CARNEGIE-MELLON UNIVERSITY UNIVERSITY OF CHICAGO CIEMAT, MADRID, SPAIN (SPAIN) COMENIUS UNIVERSITY (SLOVAKIA) DUKE UNIVERSITY FERMILAB UNIVERSITY OF FLORIDA INFN, FRASCATI (ITALY) UNIVERSITY OF GENEVA (SWITZERLAND) GLASGOW UNIVERSITY (SCOTLAND) HARVARD UNIVERSITY UNIVERSITY OF HELSINKI (FINLAND) UNIVERSITY OF ILLINOIS, CHAMPAIGN INFN, TRIESTE/UNIV DI UDINE (ITALY) IPP/MCGILL U/UN OF TORONTO (CANADA) JINR, DUBNA (RUSSIA) JOHNS HOPKINS UNIVERSITY UNIVERSITY OF KARLSRUHNE (GERMANY) KOREA CENTER FOR HEP (KOREA) LAWRENCE BERKELEY NATIONAL LAB. UNIVERSITY OF LIVERPOOL (ENGLAND) UNIVERSITY COLLEGE LONDON (ENGLAND) LPNHE, UN. OF P & M CURIE (FRANCE) MASSACHUSETTS INST. OF TECHNOLOGY UNIVERSITY OF MICHIGAN - ANN ARBOR MICHIGAN STATE UNIVERSITY ITEP, MOSCOW (RUSSIA) UNIVERSITY OF NEW MEXICO NORTHWESTERN UNIVERSITY OHIO STATE UNIVERSITY OKAYAMA UNIVERSITY (JAPAN) OSAKA CITY UNIVERSITY (JAPAN) UNIVERSITY OF OXFORD (ENGLAND) UNIVERSITY OF PADOVA (ITALY) UNIVERSITY OF PENNSYLVANIA INFN, PISA (ITALY) UNIVERSITY OF PITTSBURGH PURDUE UNIVERSITY UNIVERSITY OF ROCHESTER ROCKEFELLER UNIVERSITY UNIVERSITY OF ROME (ITALY) RUTGERS UNIVERSITY TEXAS A&M UNIVERSITY UNIVERSITY OF TSUKUBA (JAPAN) TUFTS UNIVERSITY WASEDA UNIVERSITY (JAPAN) WAYNE STATE UNIVERSITY UNIVERSITY OF WISCONSIN - MADISON YALE UNIVERSITY

917	HYPERCP PARTICLE MEASUREMENT #917 BEAM: Meson Area - Center Test to Parasitically Measure the Charge of Muon-Like Particles Emerging from the HYPERCP Beam Dump	Richard H. Gustafson	FERMILAB UNIVERSITY OF MICHIGAN - ANN ARBOR
	+-----+ Request 30 Nov, 99 Approval 20 Dec, 99 Data Analysis 17 Jan, 00 Completed 1 Mar, 01		
918	B PHYSICS AT THE TEVATRON #918 BEAM: Collision Area (C-0) Proposal for an Experiment to Measure Mixing, CP Violation and Rare Decays in Charm and Beauty Particle Decays at the Fermilab Collider - BTeV	Joel N. Butler and Sheldon Stone	BYELORUSSIAN ST UN-MINSK (BYELARUS) UNIV. OF CALIFORNIA, DAVIS UNIVERSITY OF COLORADO AT BOULDER FERMILAB UNIVERSITY OF FLORIDA INFN, FRASCATI (ITALY) UNIVERSITY OF HOUSTON ILLINOIS INSTITUTE OF TECHNOLOGY UNIVERSITY OF ILLINOIS, CHAMPAIGN UNIVERSITY OF INSUBRIA COMO (ITALY) UNIVERSITY OF IOWA INFN, MILANO (ITALY) UNIVERSITY OF MINNESOTA NANJING UNIVERSITY (PRC) NEW MEXICO STATE UNIVERSITY NORTHWESTERN UNIVERSITY OHIO STATE UNIVERSITY INFN, PAVIA (ITALY) UNIVERSITY OF PENNSYLVANIA IHEP, PROTIVNO (SERPUKHOV) (RUSSIA) UNIV. OF PUERTO RICO - MAYAGUEZ UNIV. OF SCI. & TECH., HEFEI (PRC) SHANDONG UNIVERSITY (PRC) SOUTHERN METHODIST UNIVERSITY SYRACUSE UNIVERSITY UNIVERSITY OF TENNESSEE, KNOXVILLE VANDERBILT UNIVERSITY UNIVERSITY OF VIRGINIA WAYNE STATE UNIVERSITY UNIVERSITY OF WISCONSIN - MADISON YORK UNIVERSITY (CANADA)
	+-----+ Request 15 May, 00 Approval 21 Jul, 00 Unscheduled 21 Jul, 00 Approved/Inactive 7 Feb, 05		
919	US CMS SILICON TRACKER #919 BEAM: Beam Not Applicable US CMS Silicon Tracker	Joel N. Butler	FERMILAB
	+-----+ Request 7 Jun, 00 Approval 13 Nov, 00 Unscheduled 13 Nov, 00 Setup Witin Year 1 Feb, 07		
920	CDF FORWARD DETECTORS #920 BEAM: Collision Area (B-0) Letter of Intent - A Search for the Higgs Boson Using Very Forward Tracking Detectors with CDF	Mike G. Albrow	FERMILAB ITEP, MOSCOW (RUSSIA) UNIVERSITY OF LIVERPOOL (ENGLAND) UNIVERSITY COLLEGE LONDON (ENGLAND) UNIVERSITY OF HELSINKI (FINLAND) HELSINKI INST. OF PHYSICS (FINLAND)
	+-----+ Request 26 Mar, 01 Unconsidered 26 Mar, 01		
921	CKM #921 BEAM: Main Injector - Unspecified A Proposal for a Precision Measurement of the Decay K^+ to $\pi^+\nu$ -nubar and Other Rare K^+ Processes at Fermilab Using the Main Injector	Peter S. Cooper	UNIVERSITY OF SOUTH ALABAMA BROOKHAVEN NATIONAL LABORATORY UNIVERSITY OF COLORADO AT BOLDER FERMILAB INST NUCL RESEARCH TROITSK (RUSSIA) UNIVERSITY OF MICHIGAN - ANN ARBOR IHEP, PROTIVNO (SERPUKHOV) (RUSSIA) UN.AUTO.DE SAN LUIS POTOSI (MEXICO) UNIVERSITY OF TEXAS AT AUSTIN UNIVERSITY OF VIRGINIA
	+-----+ Request 2 Apr, 01 Approval 28 Jun, 01 Unscheduled 28 Jun, 01 Approved/Inactive 1 Mar, 05		
922	KAMI #922 BEAM: Main Injector A Proposal for a Precision Measurement of the Decay KL to $\pi^0\nu$ -nubar and Other Rare Processes at Fermilab Using the Main Injector - KAMI	Ronal Ray and Yau Wah	UNIV. OF CALIFORNIA, LOS ANGELES UNIVERSITY OF COLORADO AT BOULDER FERMILAB UNIVERSITY OF CHICAGO RICE UNIVERSITY UNIVERSITY OF VIRGINIA IHEP, PROTIVNO (SERPUKHOV) (RUSSIA) UNIVERSITE OF SAO PAULO (BRAZIL) UNIV. ESTADUAL DE CAMPINAS (BRAZIL) OSAKA UNIVERSITY (JAPAN) NATIONAL TECH UN OF ATHENS (GREECE)
	+-----+ Request 2 Apr, 01 Rejected 28 Jun, 01		
923	PRIME #923 BEAM: Beam Not Applicable The PRIME Project: A Proposal for Fermilab to Join a NASA Small Explorer Program	Stephen M. Kent	FERMILAB
	+-----+ Request 8 Oct, 01 Unconsidered 8 Oct, 01 Withdrawn 13 Dec, 02		

```

=====
924  CDF RUN IIB UPGRADE #924          Jacobo Konigsberg and Robert Roser
      BEAM: Collision Area (B-0)
      The CDF IIB Detector Technical Design Report
      +-----+
      Request          9 Oct, 01
      Unconsidered     9 Oct, 01
      Approved         11 Jul, 02   Stage I
      Unscheduled      11 Jul, 02
      Setup in a Year  1 Mar, 05
      In Progress      9 Jun, 06
=====
      IHEP, ACADEMIA SINICA (TAIWAN)
      ARGONNE NATIONAL LABORATORY
      UNIVERSITY OF BARCELONA (SPAIN)
      BAYLOR UNIVERSITY
      UNIVERSITY OF BOLOGNA (ITALY)
      BRANDEIS UNIVERSITY
      UNIV. OF CALIFORNIA, DAVIS
      UNIV. OF CALIFORNIA, LOS ANGELES
      UNIV. OF CALIFORNIA, SAN DIEGO
      UNIV. OF CALIFORNIA, SANTA BARBARA
      UNIVERSITY OF CANTABRIA (SPAIN)
      CARNEGIE-MELLON UNIVERSITY
      UNIVERSITY OF CHICAGO
      CIEMAT, MADRID, SPAIN (SPAIN)
      COMENIUS UNIVERSITY (SLOVAKIA)
      DUKE UNIVERSITY
      FERMILAB
      UNIVERSITY OF FLORIDA
      INFN, FRASCATI (ITALY)
      UNIVERSITY OF GENEVA (SWITZERLAND)
      GLASGOW UNIVERSITY (SCOTLAND)
      HARVARD UNIVERSITY
      UNIVERSITY OF HELSINKI (FINLAND)
      UNIVERSITY OF ILLINOIS, CHAMPAIGN
      INFN, TRIESTE/UNIV DI UDINE (ITALY)
      IPP/MCGILL U/UN OF TORONTO(CANADA)
      JINR, DUBNA (RUSSIA)
      JOHNS HOPKINS UNIVERSITY
      UNIVERSITY OF KARLSRUHNE (GERMANY)
      KOREA CENTER FOR HEP (KOREA)
      LAWRENCE BERKELEY NATIONAL LAB.
      UNIVERSITY OF LIVERPOOL (ENGLAND)
      UNIVERSITY COLLEGE LONDON(ENGLAND)
      LPNHE, UN. OF P & M CURIE (FRANCE)
      MASSACHUSETTS INST. OF TECHNOLOGY
      UNIVERSITY OF MICHIGAN - ANN ARBOR
      MICHIGAN STATE UNIVERSITY
      ITEP, MOSCOW (RUSSIA)
      UNIVERSITY OF NEW MEXICO
      NORTHWESTERN UNIVERSITY
      OHIO STATE UNIVERSITY
      OKAYAMA UNIVERSITY (JAPAN)
      OSAKA CITY UNIVERSITY (JAPAN)
      UNIVERSITY OF OXFORD (ENGLAND)
      UNIVERSITY OF PADOVA (ITALY)
      UNIVERSITY OF PENNSYLVANIA
      INFN, PISA (ITALY)
      UNIVERSITY OF PITTSBURGH
      PURDUE UNIVERSITY
      UNIVERSITY OF ROCHESTER
      ROCKEFELLER UNIVERSITY
      UNIVERSITY OF ROME (ITALY)
      RUTGERS UNIVERSITY
      TEXAS A&M UNIVERSITY
      UNIVERSITY OF TSUKUBA (JAPAN)
      TUFTS UNIVERSITY
      WASEDA UNIVERSITY (JAPAN)
      WAYNE STATE UNIVERSITY
      UNIVERSITY OF WISCONSIN - MADISON
      YALE UNIVERSITY
=====

```

925	D-0 RUN IIB UPGRADE #925 BEAM: Collision Area (D-0) DO Run Iib Upgrade	Dmitri S. Denisov and Terry Wyatt	INST. OF PHYS. ACADEMY OF SCI (CZECH) UNIVERSITY OF ALBERTA (CANADA) UNIVERSIDAD DE LOS ANDES (COLOMBIA) UNIVERSITY OF ARIZONA UNIVERSITY OF BONN (GERMANY) BOSTON UNIVERSITY BROOKHAVEN NATIONAL LABORATORY BROWN UNIVERSITY UNIV. DE BUENOS AIRES (ARGENTINA) CALIFORNIA STATE UNIVERSITY UNIV. OF CALIFORNIA, RIVERSIDE CBPF (BRAZIL) CEA-SACLAY (FRANCE) CPPM, MARSEILLE (FRANCE) CHARLES UNIVERSIT (CZECH) CINVESTAV-IPN (MEXICO) LPN, UNIV. DE CLERMONT (FRANCE) COLUMBIA UNIVERSITY CZECH TECHNICAL UNIVERSITY (CZECH) DELHI UNIVERSITY (INDIA) UNIVERSITY COLLEGE DUBLIN (IRELAND) FERMILAB FLORIDA STATE UNIVERSITY FREIBURG UNIVERSITY (GERMANY) UNIV. OF ILLINOIS, CHICAGO CIRCLE IMPERIAL COLLEGE (ENGLAND) INDIANA UNIVERSITY INS RECHERCHES SUBATOMIQUE (FRANCE) ISN (GRENOBLE, FRANCE) IPNL (FRANCE) IOWA STATE UNIVERSITY JINR, DUBNA (RUSSIA) KANSAS STATE UNIVERSITY UNIVERSITY OF KANSAS KOREA UNIVERSITY, SEOUL (KOREA) LAL, ORSAY (FRANCE) LANCASTER UNIVERSITY (ENGLAND) LANGSTON UNIVERSITY LAWRENCE BERKELEY NATIONAL LAB. LOUISIANA TECH UNIVERSITY LPNHE, UN. OF P & M CURIE (FRANCE) LUDWIG MAXIMILIANS UNIV. (GERMANY) LUND, RIT, STOCKHOLM, UPPSALA (SWEDEN) MAINZ UNIVERSITY (GERMANY) UNIVERSITY OF MANCHESTER (ENGLAND) UNIVERSITY OF MARYLAND UNIVERSITY OF MICHIGAN - ANN ARBOR MICHIGAN STATE UNIVERSITY UNIVERSITY OF MISSISSIPPI MOSCOW STATE UNIVERSITY (RUSSIA) ITEP, MOSCOW (RUSSIA) UNIVERSITY OF NEBRASKA - LINCOLN SUNY AT BUFFALO SUNY AT STONY BROOK UN OF NIJMEGEN/NIKHEF (NETHERLANDS) NIKHEF&U OF AMSTERDAM (NETHERLANDS) NORTHEASTERN UNIVERSITY NORTHERN ILLINOIS UNIVERSITY NORTHWESTERN UNIVERSITY UNIVERSITY OF NOTRE DAME OKLAHOMA STATE UNIVERSITY UNIVERSITY OF OKLAHOMA PANJAB UNIVERSITY (INDIA) UNESP (BRAZIL) PNPI, ST. PETERSBURG (RUSSIA) PRINCETON UNIVERSITY PURDUE UNIVERSITY - CALUMET IHEP, PROTIVNO (SERPUKHOV) (RUSSIA) RICE UNIVERSITY UN. ESTADO RIO DE JANEIRO (BRAZIL) UNIVERSITY OF ROCHESTER RWTH, AACHEN (GERMANY) UN.SAN FRANCISCO DE QUITO (ECUADOR) UNIV. OF SCI. & TECH., HEFEI (PRC) SIMON FRASER UNIVERSITY (CANADA) SOUTHERN METHODIST UNIVERSITY SUNG KYUN KWAN UNIVERSITY (KOREA) TATA INSTITUTE (INDIA) UNIVERSITY OF TEXAS AT ARLINGTON UNIVERSITY OF VIRGINIA UNIVERSITY OF WASHINGTON UNIVERSITY OF WUPPERTAL (GERMANY)
	Request 11 Oct, 01 Unconsidered 11 Oct, 01 Approved 11 Jul, 02 Unscheduled 11 Jul, 02 Setup in a Year 1 Mar, 05 In Progress 9 Jun, 06	Stage I	
926	RICE TEST #T926 BEAM: Meson Area - Test Beam Radio Ice Cerenkov Experiment (RICE) Test	Alice Bean	BARTOL RESEARCH INSTITUTE FLORIDA STATE UNIVERSITY UNIVERSITY OF KANSAS MASSACHUSETTS INST. OF TECHNOLOGY NORTHERN ILLINOIS UNIVERSITY UNIVERSITY OF CANTERBURY
	Request 26 Jun, 02 Approved 11 Jul, 02 Unscheduled 11 Jul, 02 Being Installed 1 Jun, 03 Completed 15 May, 04		

927	BTeV PIXEL DETECTOR TEST #T927 BEAM: BTeV Pixel Detector Test Beam Run +-----+ Request 13 Jun, 01 Approved 6 Jun, 02 Unscheduled 6 Jun, 02 Being Installed 1 Jun, 03 In Progress 15 Dec, 03 Data Analysis 18 Jul, 05 Completed 1 Feb, 07	Joel N. Butler and Sheldon Stone UNIVERSITY OF IOWA	FERMILAB INFN, MILANO (ITALY) SYRACUSE UNIVERSITY WAYNE STATE UNIVERSITY UNIVERSITY OF WISCONSIN - MADISON
928	MINOS VETO SHIELD PROTOTYPE #T928 BEAM: Main Injector Area Proposal for Tests of a Prototype Veto Shield for MINOS +-----+ Request 15 Apr, 02 Approved 29 May, 02 Being Installed 29 May, 02 Completed 22 Jul, 03	Doug Michael and Stanley G. Wojcicki	ARGONNE NATIONAL LABORATORY UNIVERSITY OF ATHENS (GREECE) BROOKHAVEN NATIONAL LABORATORY CALIFORNIA INSTITUTE OF TECHNOLOGY UNIVERSITY OF CAMBRIDGE (ENGLAND) UNIV. ESTADUAL DE CAMPINAS (BRAZIL) FERMILAB COLLEGE DE FRANCE (FRANCE) HARVARD UNIVERSITY ILLINOIS INSTITUTE OF TECHNOLOGY INDIANA UNIVERSITY LAWRENCE LIVERMORE NATL.LABORATORY LEBEDEV PHYSICAL INST. (RUSSIA) UNIVERSITY COLLEGE LONDON (ENGLAND) MACALESTER COLLEGE UNIVERSITY OF MINNESOTA - DULUTH UNIVERSITY OF MINNESOTA ITEP, MOSCOW (RUSSIA) NORTHWESTERN UNIVERSITY UNIVERSITY OF OXFORD (ENGLAND) UNIVERSITY OF PITTSBURGH IHEP, PROTIVNO (SERPUKHOV) (RUSSIA) RUTHERFORD-APPLETON LABS. (ENGLAND) UNIVERSITE DE SAO PAULO (BRAZIL) UNIVERSITY OF SOUTH CAROLINA STANFORD UNIVERSITY SUSSEX UNIVERSITY (ENGLAND) TEXAS A&M UNIVERSITY UNIVERSITY OF TEXAS AT AUSTIN TUFTS UNIVERSITY WESTERN WASHINGTON UNIVERSITY UNIVERSITY OF WISCONSIN - MADISON
929	NOVA #929 BEAM: Main Injector - Unspecified Letter of Intent to Build an Off-Axis Detector to Study nu_mu -> nu_e Oscillations with the NuMI Neutrino Beam +-----+ Request 10 Jun, 02 Unconsidered 10 Jun, 02 Stage I Approval 20 Apr, 05	Gary J. Feldman and Mark D. Messier	ARGONNE NATIONAL LABORATORY UNIVERSITY OF ATHENS (GREECE) CALIFORNIA INSTITUTE OF TECHNOLOGY UNIV. OF CALIFORNIA, LOS ANGELES FERMILAB COLLEGE DE FRANCE (FRANCE) HARVARD UNIVERSITY INDIANA UNIVERSITY LEBEDEV PHYSICAL INST. (RUSSIA) MICHIGAN STATE UNIVERSITY UNIVERSITY OF MINNESOTA - DULUTH UNIVERSITY OF MINNESOTA ITEP, MOSCOW (RUSSIA) SUNY AT STONY BROOK NORTHERN ILLINOIS UNIVERSITY OHIO STATE UNIVERSITY UN. ESTADO RIO DE JANEIRO (BRAZIL) UNIVERSITY OF SOUTH CAROLINA SOUTHERN METHODIST UNIVERSITY STANFORD UNIVERSITY TECHNISCHE UNIV MUNCHEN (GERMANY) TEXAS A&M UNIVERSITY UNIVERSITY OF TEXAS AT AUSTIN UNIVERSITY OF TEXAS AT DALLAS TUFTS UNIVERSITY UNIVERSITY OF VIRGINIA COLLEGE OF WILLIAM AND MARY
930	BTeV STRAW TESTS #T930 BEAM: Meson Area - Test Beam BTeV Straw Prototype Detector Test +-----+ Request 13 Jun, 01 Unconsidered 13 Jun, 01 Unscheduled 14 Aug, 03 In Progress 15 May, 04 Data Analysis 15 May, 05 Completed 1 Feb, 07	Joel N. Butler and Sheldon Stone	UNIV. OF CALIFORNIA, DAVIS FERMILAB INFN, FRASCATI (ITALY) UNIVERSITY OF HOUSTON SOUTHERN METHODIST UNIVERSITY SYRACUSE UNIVERSITY UNIVERSITY OF VIRGINIA
931	BTeV MUON DETECTOR TEST #T931 BEAM: Meson Area - Test Beam BTeV Muon Detector Test +-----+ Request 14 Nov, 02 Unconsidered 14 Nov, 02 Unscheduled 14 Aug, 03 Completed 15 Feb, 05	Will E. Johns	UNIVERSITY OF ILLINOIS, CHAMPAIGN UNIV. OF PUERTO RICO - MAYAGUEZ VANDERBILT UNIVERSITY
932	DIAMOND DETECTOR TEST #T932 BEAM: Meson Area - Test Beam Diamond Detector Test +-----+ Request 14 Nov, 02 Unconsidered 14 Nov, 02 Unscheduled 3 Sep, 03 Setup in a Year 6 Jan, 06	Steven Worm	PURDUE UNIVERSITY RUTGERS UNIVERSITY

933	BTEV EM CALORIMETER TEST #T933 BEAM: BEAM: Meson Area - Test Beam BTeV Electromagnetic Calorimeter Test +-----+ Request 14 Nov, 02 Unconsidered 14 Nov, 02 In Progress 15 Jan, 05 Data Analysis 4 Jul, 05 Completed 1 Feb, 07	Pavel A. Semenov	FERMILAB UNIVERSITY OF MINNESOTA IHEP, PROTIVINO (SERPUKHOV) (RUSSIA) SYRACUSE UNIVERSITY
934	MINOS VETO SHIELD #934 BEAM: Main Injector - NuMI Proposal for Cosmic Ray Veto Shield for the MINOS Far Detector +-----+ Request 1 Jun, 02 Unconsidered 1 Jun, 02 In Progress 22 Jul, 03	Robert K. Plunkett and Stanley G. Wojcicki	ARGONNE NATIONAL LABORATORY UNIVERSITY OF ATHENS (GREECE) BROOKHAVEN NATIONAL LABORATORY CALIFORNIA INSTITUTE OF TECHNOLOGY UNIVERSITY OF CAMBRIDGE (ENGLAND) UNIV. ESTADUAL DE CAMPINAS (BRAZIL) FERMILAB COLLEGE DE FRANCE (FRANCE) HARVARD UNIVERSITY ILLINOIS INSTITUTE OF TECHNOLOGY INDIANA UNIVERSITY LEBEDEV PHYSICAL INST. (RUSSIA) UNIVERSITY COLLEGE LONDON (ENGLAND) MACALESTER COLLEGE UNIVERSITY OF MINNESOTA - DULUTH UNIVERSITY OF MINNESOTA ITEP, MOSCOW (RUSSIA) NORTHWESTERN UNIVERSITY UNIVERSITY OF OXFORD (ENGLAND) UNIVERSITY OF PITTSBURGH IHEP, PROTIVINO (SERPUKHOV) (RUSSIA) RUTHERFORD-APPLETON LABS. (ENGLAND) UNIVERSITE DE SAO PAULO (BRAZIL) UNIVERSITY OF SOUTH CAROLINA STANFORD UNIVERSITY SUSSEX UNIVERSITY (ENGLAND) TEXAS A&M UNIVERSITY UNIVERSITY OF TEXAS AT AUSTIN TUFTS UNIVERSITY WESTERN WASHINGTON UNIVERSITY UNIVERSITY OF WISCONSIN - MADISON
935	BTEV RICH TEST #935 BEAM: Meson Area - Test Beam Proposal for Cosmic Ray Veto Shield for the MINOS Far Detector +-----+ Request 1 Jun, 02 Unconsidered 1 Jun, 02 Completed 15 Jan, 05	Marina Artuso	FERMILAB SYRACUSE UNIVERSITY
936	US-CMS PIXEL DETECTOR TEST #936 BEAM: Meson Area - Test Beam Proposal for Cosmic Ray Veto Shield for the MINOS Far Detector +-----+ Request 1 Jun, 02 Unconsidered 1 Jun, 02 In Progress 15 Apr, 04 Completed 24 Jul, 06	Steven Worm	UNIV. OF CALIFORNIA, DAVIS FERMILAB JOHNS HOPKINS UNIVERSITY UNIVERSITY OF MISSISSIPPI NORTHWESTERN UNIVERSITY PURDUE UNIVERSITY RUTGERS UNIVERSITY
937	FINESSE #937 BEAM: Booster Accelerator A Proposal for a Near Detector Experiment on the Booster Neutrino Beamline: FINESSE: Fermilab Intense Neutrino Scattering Scintillator Experiment +-----+ Request 23 Nov, 03 Rejected 22 Dec, 03	Bonnie Fleming and Rex Tayloe	COLUMBIA UNIVERSITY FERMILAB UNIVERSITY OF ILLINOIS, CHAMPAIGN INDIANA UNIVERSITY LOS ALAMOS NATIONAL LABORATORY LOUISIANA STATE UNIVERSITY NEW MEXICO STATE UNIVERSITY UNIVERSITY OF VIRGINIA
938	HIGH-STATISTICS NEUTRINO SCATTERING #938 BEAM: Main Injector - NuMI Proposal to Perform a High-Statistics Neutrino Scattering Experiment Using a Fine-Grained Detector in the NuMI Beam (MINERvA) +-----+ Request 3 Dec, 03 Unconsidered 3 Dec, 03 Approved 15 Apr, 05	Kevin McFarland and Jorge Morfin	UNIVERSITY OF ATHENS (GREECE) UNIV. OF CALIFORNIA, IRVINE CEBAF - THOMAS JEFFERSON LAB. DORTMUND UNIVERSITY (GERMANY) FERMILAB HAMPTON UNIVERSITY ILLINOIS INSTITUTE OF TECHNOLOGY UNIV. NACIONAL DE INGENIERIA (PERU) INST. FOR NUCLEAR RESEARCH (RUSSIA) JAMES MADISON UNIVERSITY UNIVERSITY OF MINNESOTA - DULUTH NORTHERN ILLINOIS UNIVERSITY NORTHWESTERN UNIVERSITY UNIVERSITY OF PITTSBURGH PONTIFICA UN. CATOLICA PERU (PERU) UNIVERSITY OF ROCHESTER RUTGERS UNIVERSITY UNIVERSITY OF TEXAS AT AUSTIN TUFTS UNIVERSITY COLLEGE OF WILLIAM AND MARY
939	DARK ENERGY SURVEY #939 BEAM: Other Proposal for Fermilab to Support the Dark Energy Survey Design and Development +-----+ Request 11 Mar, 04 Approved 13 Jul, 04 Stage I	James Annis and Brenna Flaugher	FERMILAB

940	CHARGED KAONS RARE DECAYS #940 BEAM: Main Injector - New Muon An Adaptation to an Existing Facility of the E-921 Precision Measurement of the Decay $K^+ \rightarrow \pi^+ \nu \mu$ and Other Rare and Precision Measurements in K^+ and π^+ Decays +-----+ Request 2 Apr, 04 Unconsidered 15 Apr, 04 Not Approved 20 Apr, 05	Peter Cooper	UNIVERSITY OF SOUTH ALABAMA BROOKHAVEN NATIONAL LABORATORY UNIVERSITY OF COLORADO AT BOULDER FERMILAB INST NUCL RESEARCH TROITSK(RUSSIA) UNIVERSITY OF MICHIGAN - ANN ARBOR IHEP, PROTIVNO (SERPUKHOV) (RUSSIA) UN.AUTO.DE SAN LUIS POTOSI(MEXICO) UNIVERSITY OF TEXAS AT AUSTIN UNIVERSITY OF VIRGINIA
941	PPAC #T941 BEAM: Meson Area - Test Beam Parallel Plate Avalanche Counter Test +-----+ Request 4 Jun, 04 Approved 19 Jul, 04 Completed 15 Jan, 05	Edwin Norbeck	UNIVERSITY OF IOWA
942	FLARE # 942 BEAM: Unspecified Letter of Intent for FLARE: Fermilab Liquid Argon Experiments +-----+ Request 8 Jun, 04 Not Approved 15 Jul, 04	Adam Para	BARTOSZEK ENGINEERING UNIV. OF CALIFORNIA, LOS ANGELES DUKE UNIVERSITY FERMILAB INDIANA UNIVERSITY LOUISIANA STATE UNIVERSITY MICHIGAN STATE UNIVERSITY OSAKA UNIVERSITY (JAPAN) INFN, PISA (ITALY) UNIVERSITY OF PITTSBURGH PRINCETON UNIVERSITY UNIVERSITY OF SILESIA (POLAND) UNIVERSITY OF SOUTH CAROLINA TEXAS A&M UNIVERSITY TUFTS UNIVERSITY WARSAW UNIVERSITY, INS (POLAND) WARSAW UNIVERSITY, INP, (POLAND) UNIVERSITY OF WASHINGTON YORK UNIVERSITY (CANADA)
943	MONOLITHIC ACTIVE PIXEL DETECTOR #T943 BEAM: Meson Area - Test Beam Super B-factory Monolithic Active Pixel Detector Prototype +-----+ Request 29 Aug, 04 Approved 24 Sep, 04 Completed 15 Jan, 05	Gary Varner	UNIVERSITY OF HAWAII AT MANOA KEK (JAPAN) INP, KRAKOW (POLAND) UNIVERSITY OF TSUKUBA (JAPAN)
944	MINIBOONE ANTINEUTRINO #944 BEAM: Booster MiniBooNE Extension +-----+ Request 28 Oct, 04 Approved 18 Nov, 04 Setup in a Year 18 Nov, 04 In Progress 23 Jan, 06	Stephen Brice and Richard Van de Water	UNIVERSITY OF ALABAMA BUCKNELL UNIVERSITY UNIVERSITY OF CINCINNATI UNIVERSITY OF COLORADO AT BOULDER COLUMBIA UNIVERSITY EMBRY RIDDLE AERONAUTICAL UNIV. FERMILAB IMPERIAL COLLEGE (ENGLAND) INDIANA UNIVERSITY LOS ALAMOS NATIONAL LABORATORY LOUISIANA STATE UNIVERSITY UNIVERSITY OF MICHIGAN - ANN ARBOR PRINCETON UNIVERSITY ST. MARY'S UNIVERSITY OF MINNESOTA VIRGINIA POLYTECHNIC & STATE UNIV. WESTERN ILLINOIS UNIVERSITY YALE UNIVERSITY
945	COUPP #T945 BEAM: Other Chicagoland Observatory for Underground Particle Physics +-----+ Request 29 Jul, 04 Approved 4 Feb, 05 Unscheduled 4 Feb, 05 In Progress 8 Feb, 05	Juan Collar	UNIVERSITY OF CHICAGO FERMILAB
946	FINeSSE #946 BEAM: Booster A Letter of Intent for a Neutrino Scattering Experiment on the Booster Neutrino Beamline: FINeSSE +-----+ Request 21 Mar, 05 Not Approved 20 Apr, 05	Bonnie Fleming and Rex Tayloe	COLUMBIA UNIVERSITY FERMILAB UNIVERSITY OF ILLINOIS, CHAMPAIGN INDIANA UNIVERSITY LOS ALAMOS NATIONAL LABORATORY LOUISIANA STATE UNIVERSITY NEW MEXICO STATE UNIVERSITY YALE UNIVERSITY
947	SUPERCDMS #947 BEAM: Other SuperCDMS Development Project +-----+ Request 1 Oct, 04 Unconsidered 20 Apr, 05	Dan Bauer	FERMILAB
948	MIPP Upgrade #948 BEAM: Main Injector Proposal to Upgrade the DAQ for the Main Injector Particle Production Experiment (MIPP) at Fermilab +-----+ Request 29 Mar, 05 Rejected 20 Apr, 05	Rajendran Raja	BROOKHAVEN NATIONAL LABORATORY UNIVERSITY OF COLORADO AT BOULDER ELMHURST COLLEGE ENRICO FERMI INSTITUTE FERMILAB HARVARD UNIVERSITY ILLINOIS INSTITUTE OF TECHNOLOGY INDIANA UNIVERSITY UNIVERSITY OF IOWA LAWRENCE LIVERMORE NATIONAL LAB. UNIVERSITY OF MICHIGAN - ANN ARBOR PURDUE UNIVERSITY UNIVERSITY OF SOUTH CAROLINA UNIVERSITY OF VIRGINIA

949	SDSS-II #949 BEAM: Other An Extension of the Sloan Digital Sky Survey +-----+ Request 15 Mar, 04 Stage I Approval 15 Apr, 04 Stage II Approval 20 Apr, 05 In Progress 1 Jul, 05	Steven Kent	FERMILAB
950	VACUUM STRAW TRACKER #T950 BEAM: Meson Area - Test Beam Vacuum Straw Tracker Test Beam Run +-----+ Request 4 Aug, 05 Approved 15 Sep, 05 In Progress 7 Nov, 05	Yau Wei Wah	UNIVERSITY OF CHICAGO FERMILAB OSAKA UNIVERSITY (JAPAN)
951	ALICE EMCAL #T951 BEAM: Meson Area - Test Beam ALICE Electromagnetic Calorimeter Prototype Test +-----+ Request 20 Jul, 05 Approved 13 Oct, 05 In Progress 7 Nov, 05 Completed 4 Dec, 05	Terry Awes	UNIV. OF CALIFORNIA, BERKELEY UNIV. OF CALIFORNIA, LOS ANGELES CREIGHTON UNIVERSITY UNIVERSITY OF HOUSTON LAWRENCE BERKELEY NATIONAL LAB. LAWRENCE LIVERMORE NATIONAL LAB. MICHIGAN STATE UNIVERSITY OAK RIDGE NATIONAL LABORATORY OHIO STATE UNIVERSITY PURDUE UNIVERSITY UNIVERSITY OF TENNESSEE, KNOXVILLE UNIVERSITY OF WASHINGTON WAYNE STATE UNIVERSITY
952	PEANUT #T952 BEAM: Main Injector - NuMI Test of OPERA Targets in the NuMI Beam (Petit-Exposure At NeUtrino beamline - PEANUT) +-----+ Request 3 Aug, 05 Approved 12 Aug, 05 In Progress 13 Oct, 05	Kimio Niwa	AICHI UNIV. OF EDUCATION (JAPAN) UNIVERSITY OF ATHENS (GREECE) UNIVERSITY OF BARI (ITALY) UNIVERSITY OF BOLOGNA (ITALY) UNIV. FEDERICO SANTA MARIA (CHILE) FERMILAB INFN, FRASCATI (ITALY) IPNL (FRANCE) KOBE UNIVERSITY (JAPAN) LA SAPIENZA UNIV. AND INFN (ITALY) NAGOYA UNIVERSITY (JAPAN) UNIVERSITY OF PADOVA (ITALY) UNIVERSITY OF PITTSBURGH SALERNO UNIVERSITY AND INFN (ITALY)
953	CERENKOV TEST #T953 BEAM: Meson Area - Test Beam University of Iowa Cerenkov Light Test +-----+ Request 7 Sep, 05 Approved 13 Oct, 05 Setup Witin Year 13 Oct, 05 In Progress 13 Feb, 06	Edwin Norbeck	UNIVERSITY OF IOWA UNIVERSITY OF WISCONSIN - MADISON
954	SCIBOONE #954 BEAM: Booster Bringing the SciBar Detector to the Booster Neutrino Beam +-----+ Request 10 Jun, 05 Stage I Approval 14 Dec, 05 Unscheduled 14 Dec, 05 Setup Witin Year 20 Sep, 06	Tsuyoshi Nakaya and Morgan Wascko	CHONNAM NATIONAL UNIVERSITY (KOREA) UNIVERSITY OF CINCINNATI UNIVERSITY OF COLORADO AT BOULDER COLUMBIA UNIVERSITY DONGSHIN UNIVERSITY (KOREA) FERMILAB ICRR, UNIVERSITY OF TOKYO (JAPAN) IFAE-BARCELONA (SPAIN) IMPERIAL COLLEGE (ENGLAND) INDIANA UNIVERSITY KEK (JAPAN) KYOTO UNIVERSITY (JAPAN) LA SAPIENZA UNIV AND INFN (ITALY) LOS ALAMOS NATIONAL LABORATORY LOUISIANA STATE UNIVERSITY PURDUE UNIVERSITY (CALUMET CAMPUS) SAINT MARY'S UNIV. OF MINNESOTA SEOUL NATIONAL UNIVERSITY (KOREA) TOKYO INST. OF TECHNOLOGY (JAPAN) IFC, VALENCIA (SPAIN)
955	RPC TEST #T955 BEAM: Meson Area - Test Beam Resistive Plate Chamber Detector Test +-----+ Request 7 Nov, 05 Approved 21 Dec, 05 Setup Witin Year 21 Dec, 05 In Progress 1 Feb, 06	David Underwood	ARGONNE NATIONAL LABORATORY UNIVERSITY OF IOWA
956	ILC MUON DETECTOR #T956 BEAM: Meson Area - Test Beam ILC Muon Detector Tests +-----+ Request 20 Dec, 05 Approved 4 Feb, 06 Setup Witin Year 4 Feb, 06 In Progress 20 Feb, 06	Robert Abrams	UNIVERSITY OF CALIFORNIA, DAVIS FERMILAB INDIANA UNIVERSITY UNIVERSITY OF NOTRE DAME WAYNE STATE UNIVERSITY

957	TAIL-CATCHER/MUON #T957 BEAM: Meson Area - Test Beam Northern Illinois University Tail-catcher/Muon Tracker Test -----+ Request 30 Dec, 05 Approved 4 Feb, 06 Setup Witin Year 4 Feb, 06 In Progress 13 Feb, 06	Vishnu Zutshi	DESY (GERMANY) IMPERIAL COLLEGE (ENGLAND) NORTHERN ILLINOIS UNIVERSITY
958	FP420 FAST TIMING #T958 BEAM: Meson Area - Test Beam FP420 Fast Timing Test -----+ Request 23 May, 06 Approved 23 Jun, 06 In Progress 16 Jul, 06	Andrew Brandt	UNIVERSITY OF ALBERTA (CANADA) FERMILAB UNIVERSITY OF TEXAS AT ARLINGTON UN. CATHOLIQUE DE LOUVAIN (BELGIUM)
959	MICROPARTICLE SHIELDING #T959 BEAM: Meson Area - Test Beam Microparticle Shielding Assessment -----+ Request 1 Jun, 06 Approved 21 Nov, 06 In Progress 13 Dec, 06 Completed 20 Dec, 06	Nolan Hertel	GEORGIA INSTITUTE OF TECHNOLOGY UNIVERSITY OF KENTUCKY
960	MIPP UPGRADE #960 BEAM: Main Injector - M Center Proposal to Upgrade the MIPP Experiment -----+ Request 26 Sep, 06 Deferred 6 Nov, 06	Rajendran Raja	ABILENE CHRISTIAN UNIVERSITY UNIVERSITY OF COLORADO AT BOULDER GSI, DARMSTADT (GERMANY) FERMILAB GEORGE WASHINGTON UNIVERSITY HARVARD UNIVERSITY ILLINOIS INSTITUTE OF TECHNOLOGY INDIANA UNIVERSITY UNIVERSITY OF IOWA JINR, DUBNA (RUSSIA) KENT STATE UNIVERSITY KVI (GRONINGEN, NETHERLANDS) UNIVERSITY OF MICHIGAN - ANN ARBOR PNPI, ST. PETERSBURG (RUSSIA) PURDUE UNIVERSITY RUTGERS UNIVERSITY UNIVERSITY OF SOUTH CAROLINA UNIVERSITY OF UTAH UNIVERSITY OF VIRGINIA UNIVERSITY OF WISCONSIN - MADISON
961	COUPP #961 BEAM: Beam Not Applicable COUPP - A Search for Dark Matter with a Continuously Sensitive Bubble -----+ Request 22 Sep, 06 Approved 6 Nov, 06 Setup Witin Year 6 Nov, 06	Juan Collar	UNIVERSITY OF CHICAGO FERMILAB INDIANA UNIVERSITY, SOUTH BEND
962	MINI LAR TPC #T962 BEAM: Meson Area - Test Beam Mini Liquid Argon TPC Test -----+ Request 25 Jul, 06 Unconsidered 25 Jul, 06	Bonnie Fleming	FERMILAB MICHIGAN STATE UNIVERSITY YALE UNIVERSITY
963	STAR MUON TELESCOPE #T963 BEAM: Meson Area - Test Beam STAR Muon Telescope Detector -----+ Request 1 Jan, 07 Unconsidered 1 Jan, 07	Zhangbu Xu	BROOKHAVEN NATIONAL LABORATORY UNIV. OF CALIFORNIA, LOS ANGELES RICE UNIVERSITY UNIV. OF SCI. & TECH., HEFEI (PRC) UNIVERSITY OF TEXAS AT AUSTIN TSINGHUA UNIVERSITY (PRC) YALE UNIVERSITY
964	GDH #T964 BEAM: Meson Area - Test Beam GEM for Digital Hadron Calorimetry -----+ Request 9 Jan, 07 Unconsidered 9 Jan, 07	Jae Yu	UNIVERSITY OF TEXAS AT ARLINGTON
965	PHOTOSENSOR TESTS #T965 BEAM: Meson Area - Test Beam Readout of Scintillator/WLS Detectors with Pixelated Silicon Photosensors (PSiPs) -----+ Request 7 Dec, 06 Unconsidered 7 Dec, 06	Robert Wilson	COLORADO STATE UNIVERSITY FERMILAB

*** End of Report ***

