



THE ED/S CRYOSTAT VACUUM CONTROL SYSTEM

L. Bartelson and H. Jöbstlein

January 1980

Figure 1 shows the layout of the control panel which is under construction (two channels) for testing at the A2 test cryoloop.

The gate valves C or D open when all of the following conditions are met:

- AIR Air pressure for valve actuator is above 70 psi.
- RPI The roughing pump is running, as determined from the observation that it draws 1 A of current or more.
- D.P. (Differential Pressure). Less than two volts absolute difference between the outputs of RP and MP. This translates into a factor of 10 to 100 in pressure, since the scales are roughly logarithmic. Atmospheric pressure is within two volts of 10 Torr (see Fig. 2).
- Δ RP The current value of RP is compared to the average reading over the last 30 seconds. If the pressure has risen by more than 1 volt (see above), the valve closes. This feature protects the system in cases where RP and MP track sufficiently to avoid valve closing. The valves will stay closed until the operator requests them to open.
- REQUEST TO OPEN Needs to be posted by the operator to cause the valve to open as soon as all the other conditions are met. It is treated just like the other conditions. The request is removed automatically whenever the valve closes (loss of power, pump failure, etc.).
- Turbo+ $\overline{\text{RP}}$ Requires the turbo pump to run whenever the fore vacuum is adequate (same threshold as the one that turns the turbo pump on). This will prevent oil fumes from entering the system when only the roughing pump is running. A time delay of 1 second fakes this requirement while the turbopump is in the startup mode.



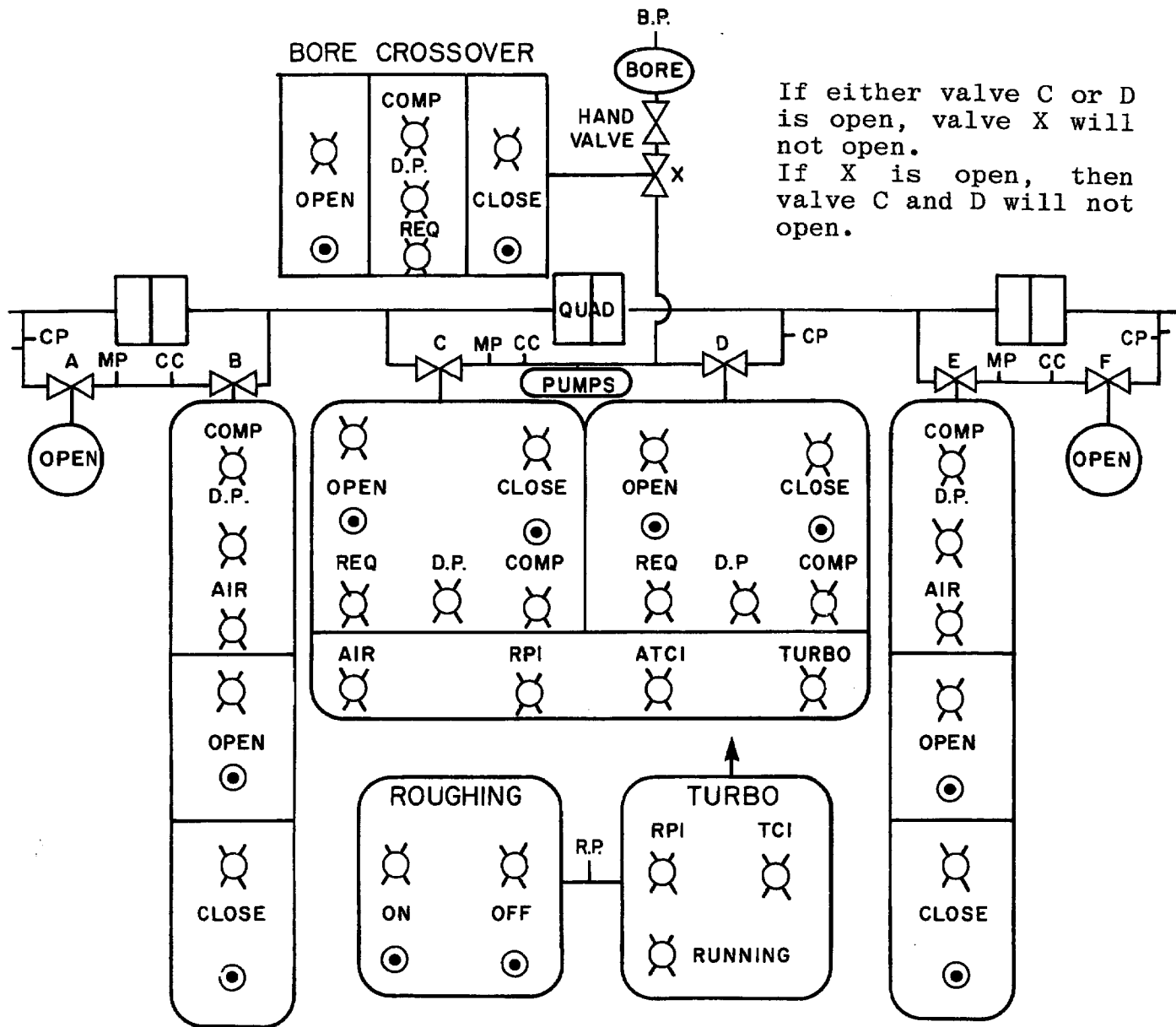

If either valve C or D is open, valve X will not open.
 If X is open, then valve C and D will not open.

- RP = Roughing pressure)
- MP = Manifold pressure) Pirani Gauges
- CP = Cryostat pressure) (Convectron)
- BP = Bore pressure)
- ⊗ Indicator light
- ⊙ Push button
- CC = Cold cathode gauge

Fig. 1. Control panel for two pump stations and two bypass manifolds to be tried at the A2 cryoloop.

The panel also controls a valve in a "cross-over" line used to rough pump the bore tube prior to ion pumping.

COMP Indicates the system is under computer control. In this mode the front panel controls are disabled. Computer programs can initiate any action which does not violate the hardware interlocks described above.

TURBO This light is on whenever the turbopump is drawing current. It will go out when, e.g., the contactor for the turbo trips on overload.

RUNNING

The **turbopump** runs whenever the fore vacuum (RP) is adequate (under 1 Torr). RP will have a large hysteresis in its threshold (about 1 volt; see above) to avoid on-off cycling due to the foreline pressure rise on startup.

There is no manual off switch for the turbo pump, as it is undesirable to run with a roughing pump alone for any period of time due to the danger of oil vapors entering the cryostat. A contactor protects each turbopump and can only be reset manually in the service building.

Modes of Operation

1. Normal status

RPI on; roughing pump is running

AIR OK

Valves open or closed, depending on the need to pump on a cold cryostat

RP-MP approx. zero

Δ RP approx. zero

Turbopump running

2. Pumpdown from Atmospheric Pressure

The operator posts a "Request to Open" for the gate valve. On the dual pump stations (with vacuum barrier) he closes the valve for the half which is not to be pumped. At this time the interlock status is:

RP-MP reads zero volts, if the roughing pump is off, implying that the pump station is vented. This is a necessary condition for the valve to open.

ΔRP reads zero (no recent rise in pressure)

AIR pressure needs to be OK

TURBO+ $\overline{\text{RP}}$ Will be "TRUE," since RP will read "bad."

At this point the valve will open. If the operator forgot to close the valve to the other half of the string, and if that half is under vacuum (it cannot be cold if one half is at atmospheric), this valve will close when the roughing pump goes off, and without admitting a large amount of air.

The operator then starts the roughing pump, which closes the vent valve. When RP reaches the set point (approx. 1 Torr) for the turbopump, the turbo will start. If the turbopump fails to turn on the valve will close and stay closed until the turbopump is again in operation and a new request to open is issued. This is an alarm condition.

3. Cryostat Under Vacuum; Resume Pumping After Pump Station Was Off

The operator posts a "request to open" for the appropriate valve. If the roughing pump is still off (hence the pump station vented), the "RP-MP" condition will prevent the valve from opening. When the roughing pump is started, this condition (and the RPI condition) is soon fulfilled, and the valve opens (and the turbopump starts).

4. Power Failure

The valve closes, the roughing pump stops, and the pump station is vented bringing the turbopump to a rapid stop (no damage). If control power fails, too, then the control box will,

upon power return, remain in a state with the valves closed, since the "request to open" is removed on power-up. An alarm will be generated by the computer. Operator intervention is required to resume pumping (see #3). This guards against "hiccups" often observed when power returns. The roughing and turbopumps will stay off on power return.

5. Cryostat at Atmospheric Pressure, Valve Closed, Pumps On

Under this condition it is not good to open the valve, especially since the other branch of magnets might be under vacuum. The "RP-MP" condition prevents it. The operator first stops the roughing pump (venting the pump station) and then resumes pumpdown as under #2.

6. Leak into Cryostat

If a leak suddenly opens, the rate of rise interlock " Δ RP" will close both valves at the pump station (alarm condition).

A slowly developing leak (or outgassing on warm-up) will not cause any action until one of two things happen:

- a. The RP condition fails, shutting the turbopump off until the vacuum recovers. Shutoff occurs at 10 Torr, turn-on at 1 Torr (hysteresis). During the time high pressure prevails, the roughing pump continues to operate. Oil mists are not likely to contaminate the cryostat as one is in the viscous flow regime (or close to it).
- b. The turbopump may overheat and stop on failure. If RP is still good enough at this time, the valve will close, and no rough pumping is done until the contactor is reset in the service building.

In either case this is an alarm condition.

7. Leak into the Pump Station

A leak into the pump station, i.e., on the roughing side of the turbo pump, caused e.g., by a malfunctioning vent valve, will most likely first trigger the RP-MP interlock, closing the valve, which will stay closed.

The leak will also probably trigger RP, shutting down the turbopump. This is an alarm condition in any case.

8. Gauge Failure

Gauges will be so constructed that a loss of the drive current (e.g., cable unplugged) will cause an alarm. Only Pirani type gauges are used in the insulating vacuum control system.

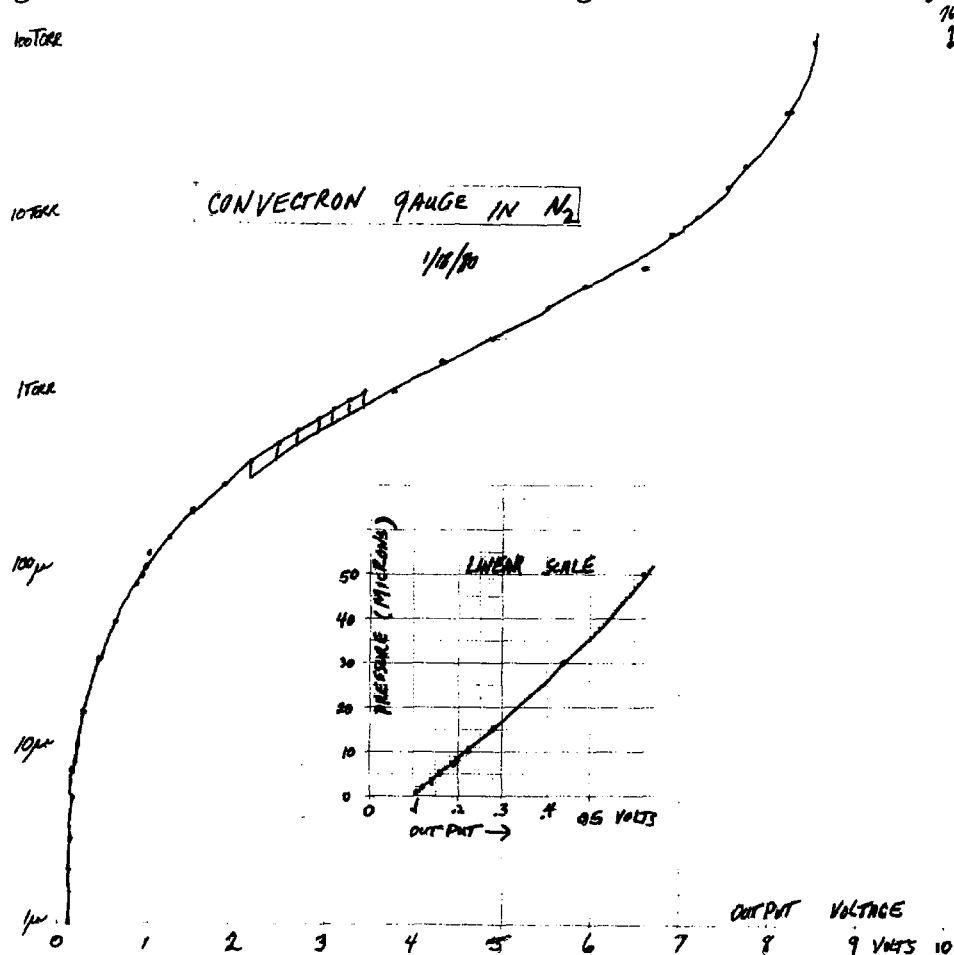

Fig. 2. Response of Pirani gauge (Granville-Phillips "Convectron").