

## Liquid scintillator tiles for calorimetry

M. Amouzegar,<sup>a</sup> A. Belloni,<sup>a,1</sup> B. Bilki,<sup>b</sup> J. Calderon,<sup>a</sup> P. De Barbaro,<sup>c</sup> S.C. Eno,<sup>a</sup>  
K. Hatakeyama,<sup>d</sup> J. Hirschauer,<sup>e</sup> G.Y. Jeng,<sup>a</sup> N.J. Pastika,<sup>d</sup> K. Pedro,<sup>e</sup> Paolo Rumerio<sup>f,g</sup>  
J. Samuel,<sup>a</sup> E. Sharp,<sup>h</sup> Y.H. Shin,<sup>a</sup> E. Tiras,<sup>b</sup> D. Vishnevskiy,<sup>c</sup> J. Wetzel,<sup>b</sup> Z. Yang,<sup>a</sup> Y. Yao<sup>a</sup>  
and S.W. Youn<sup>i</sup>

<sup>a</sup>Department of Physics, University of Maryland,  
College Park, MD, U.S.A.

<sup>b</sup>Department of Physics, University of Iowa,  
Iowa City, IA, U.S.A.

<sup>c</sup>Department of Physics, University of Rochester,  
Rochester, NY, U.S.A.

<sup>d</sup>Department of Physics, Baylor University,  
Waco, Texas, U.S.A.

<sup>e</sup>Fermi National Accelerator Laboratory,  
Batavia, IL, U.S.A.

<sup>f</sup>Department of Physics, The University of Alabama,  
Tuscaloosa, U.S.A.

<sup>g</sup>CERN, European Organization for Nuclear Research,  
Geneva, Switzerland

<sup>h</sup>Elmer Sharp Engineering,  
7007 Leesville Blvd. Springfield, VA 22151, U.S.A.

<sup>i</sup>Department of Physics, Institute for Basic Science, Center for Axion and Precision Physics Research,  
Yuseong-gu, Daejeon 305-701, South Korea

E-mail: [abelloni@umd.edu](mailto:abelloni@umd.edu)

**ABSTRACT:** Future experiments in high energy and nuclear physics may require large, inexpensive calorimeters that can continue to operate after receiving doses of 50 Mrad or more. The light output of liquid scintillators suffers little degradation under irradiation. However, many challenges exist before liquids can be used in sampling calorimetry, especially regarding developing a packaging that has sufficient efficiency and uniformity of light collection, as well as suitable mechanical properties. We present the results of a study of a scintillator tile based on the EJ-309 liquid scintillator using cosmic rays and test beam on the light collection efficiency and uniformity, and some preliminary results on radiation hardness.

**KEYWORDS:** Calorimeters; Liquid detectors; Radiation-hard detectors; Scintillators and scintillating fibres and light guides

<sup>1</sup>Corresponding author.



---

## Contents

<b>1</b>	<b>Introduction</b>	<b>1</b>
<b>2</b>	<b>Tile design</b>	<b>1</b>
<b>3</b>	<b>Light yield and uniformity as measured in test beam</b>	<b>2</b>
<b>4</b>	<b>Light yield dependence on tile parameters</b>	<b>4</b>
<b>5</b>	<b>Radiation hardness tests</b>	<b>6</b>
<b>6</b>	<b>Comparison with simulation and optimization</b>	<b>6</b>
<b>7</b>	<b>Conclusions</b>	<b>8</b>

---

## 1 Introduction

Sampling calorimeters using plastic scintillator tiles with wavelength-shifting (WLS) fibers as their active element, such as the CDF plug calorimeter [1], the ATLAS tile calorimeter [2], and the CMS Barrel [3] and Endcap [4] hadron calorimeters, are popular due to their low cost and ease of construction. Plastic scintillator is available commercially from companies such as St. Gobain and Eljen Technology. When irradiated, however, the performance of plastic scintillator and WLS fibers deteriorates; light self-absorption (yellowing) increases and light output decreases. The resulting loss of light output has been studied using irradiations from electron linacs and  $^{60}\text{Co}$  sources [5, 6]. Generally, the light output decreases exponentially with dose, with a decay constant on the order of 10 Mrad. Future high energy and nuclear experiments, however, may have to operate in environments that will deliver doses of many tens of Mrad. Previous studies of liquid scintillator have shown little decrease of light output with dose [7–10]. However, there are challenges in the designing of a package with sufficient light output and uniformity, as well as adequate mechanical properties. In this paper, we present the design and optimization of a liquid scintillator tile for uniformity of light output and discuss some remaining challenges regarding other mechanical properties that remain. An earlier liquid tile design by another group is described in [11].

## 2 Tile design

Our tile is based on the EJ-309 scintillator, from Eljen Technology, which uses a naphthalene substrate with wavelength-shifting additives. EJ-309 has a light output that is 75% of anthracene, a wavelength of maximum emission of 424 nm, a volumetric thermal expansion coefficient of  $0.1\%/^{\circ}\text{C}$ , a refractive index of 1.57, and a flash point of  $144^{\circ}\text{C}$ . It is classified as a Class IIIB combustible liquid. The high flash point is important for its suitability for a collider environment.

Its cost is similar, per unit of volume, to plastic scintillators, and the possibility of producing large quantities of scintillator has been discussed with Eljen Technology.

The design of a tile to hold the liquid needs to consider light collection efficiency, light collection uniformity, and cost. The container should not leak, and there should not be interactions between the container and its contents that degrade the light output over time or compromise the integrity of the container. Figure 1 shows the mechanical construction of our prototype. The case is made of aluminum. Two transparent quartz support tubes run through the liquid and can hold either a WLS fiber or liquid wavelength shifter. When a WLS fiber was used, the end of the fiber not connected to the photodetector was coated with Al to increase the light output unless otherwise noted. The support tube is sealed to the case with a Viton fluoroelastomer O-ring.<sup>1</sup> The usage of an O-ring seal simplified the design of our container, however the radiation tolerance of Viton was not tested. The thicknesses of the top and bottom aluminum plates are 0.5 mm. The total internal volume is 88 mm x 88 mm x 4 mm. The inner surface of the container is lapped and polished Al-6016-T6 (as suggested by Eljen). The material comes with a plastic coating, used to maintain its mirror quality during the machining process and then removed before the welding step. The liquid was transferred into the container in an inert atmosphere, as contamination with oxygen decreases the light output.

Several variations on this design were constructed. For the default design, the thickness of the liquid is 4 mm. A version with a 6 mm thickness was also made. The default support tubes (quartz1), from Atlantic International, were quartz with an inner diameter of 1.3 mm and an index of refraction of 1.600, measured at the Quattrone Nanofabrication Facility at the University of Pennsylvania. Double-clad plastic scintillating fibers from Kuraray (Y-11) with a doping of 200 ppm were used as WLS fibers. As an alternative, two types of quartz tubes filled with liquid wavelength shifter (capillaries) were also used. One set of ordinary quartz (quartz2) had an outer diameter of 2 mm, an inner diameter of 1 mm, and a measured index of refraction of 1.548. Another set used special radiation-resistant quartz (quartz3) and had an outer diameter of 1 mm and an inner diameter of 0.4 mm. Its index was not measured. The dimensions of the quartz3 configuration are not optimal in any sense for this design, but funding was not available to allow the construction of a more suitable liquid capillary with radiation hard quartz. The liquid wavelength shifter was a prototype material from Eljen, and is not yet a commercial item. The liquid wavelength shifter has an emission maximum from between 481 and 492 nm and a decay time between 2 and 8 ns. The solvent was the same as that used for EJ-309.

In what follows, the results shown are for the mirrored tile with 4 mm thickness, the quartz1 support tubes, and 0.9 mm diameter Y-11 WLS fibers, unless otherwise stated.

### 3 Light yield and uniformity as measured in test beam

The light yield and uniformity of the tiles were measured in the H2 test beam facility at CERN using 120 GeV muons. The trigger required coincidence of two out of four plastic scintillator hodoscopes. The effective beam cross-sectional area, after trigger requirements, was 14x14 cm<sup>2</sup>. The positions of the muons were measured with four wire chambers. We required the signal in each wire chamber

<sup>1</sup>EJ-309 interacts with common O-ring materials such as neoprene or Buna-N.

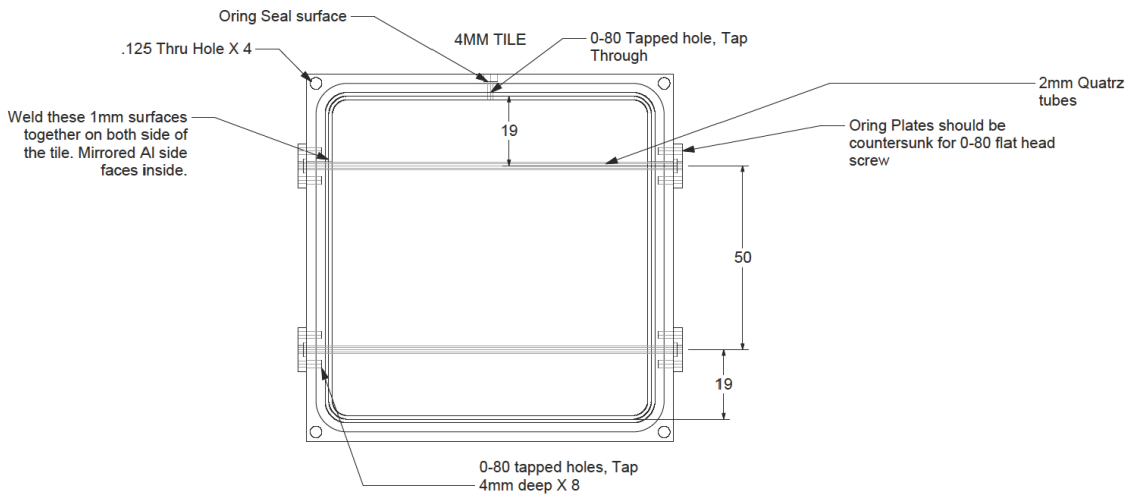
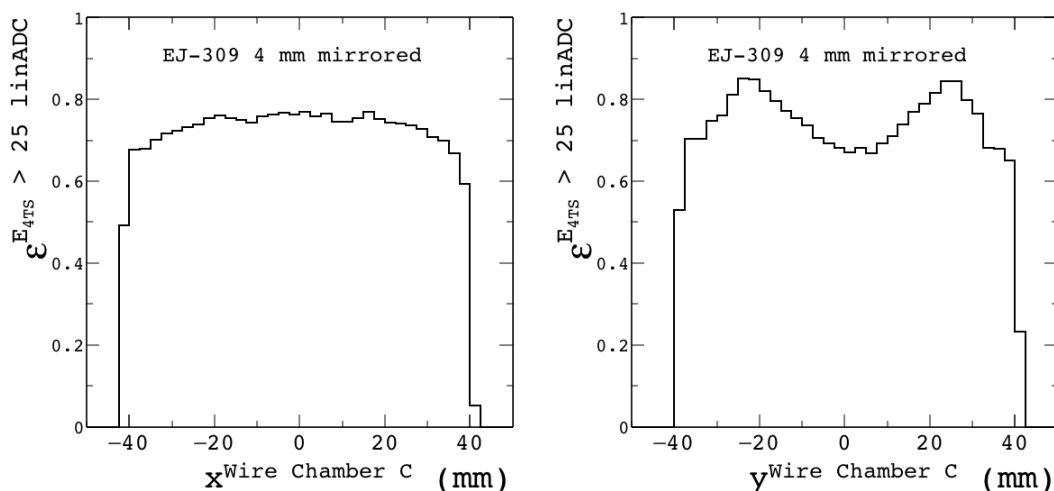

**Figure 1.** Mechanical design of a liquid scintillator tile. Units are [mm].

be consistent with that of a single muon, and that the difference in positions in sequential chambers be consistent within uncertainties. The position obtained from the wire chamber closest to the prototype was used to represent the muon hit position on the prototype. As many groups were using the same test beam, there were materials upstream of our samples for some runs, such as steel blocks used to support other experiments. Because the muons were high energy, the probability of a muon-induced shower was non-negligible. This was verified later at a test beam at Fermi National Accelerator Laboratory (FNAL), which had a cleaner beam line, by varying the amount of material in front of the tile, and through simulations with varying amounts of material. We present here the results from the runs and tiles with the least upstream material.

The WLS fibers were connected to clear fibers using a connector designed at FNAL. The clear fibers were led away from the beam line. The light output was measured using a Hamamatsu R7600U-200-M4 photomultiplier tube and a custom ASIC that integrates and digitizes the resulting charge, called the “QIE” [12]. The photomultiplier has a peak quantum efficiency of 40% at a wavelength of 400 nm and produces a clear single photo-electron (p.e.) peak. The integrated charge is digitized every 25 ns. Ten digitizations were recorded per muon trigger. The sum of the signal in four consecutive time samples was used.

The average number of p.e.’s produced per minimum ionizing particle (mip) was estimated by doing a Gaussian fit to the peak centered on the pedestal. The mean number of p.e.’s was calculated using the fraction of events in this peak, assuming a Poisson distribution. The nominal tile produced 1.7 p.e.’s per mip. A plastic tile (SCSN-81 with Y-11 fiber) with dimensions 10 cm x 10 cm x 3.7 mm tested at the same time gave 1.8 p.e./mip. The results have a systematic uncertainty related to the handling of the events with showering muons. We evaluate this uncertainty by looking at the results after truncating the distribution at around 25 p.e.’s (2000 adc counts). The results were stable to within 5%. In addition, runs taken with varying amounts of material in front of our detector (up to 20 cm of steel) resulted in a 15% variation in light yield. We therefore assign a 16% uncertainty due to upstream material.



**Figure 2.** For the nominal liquid tile, fraction of muons with at least one photoelectron as a function of the impact position of the muon along the axis parallel to the support tubes (left) and perpendicular to the support tubes (right).

The uniformity of the light collection was also studied at the CERN test beam. Figure 2 shows the fraction of events with at least 1 p.e. versus the impact position of the mip along the axis parallel to the support tubes (left) and perpendicular to the support tubes (right). As expected, there is little dependence on the coordinate parallel to the support tubes. The light yield does depend on the perpendicular distance. The light collection efficiency is maximal for muons near the WLS fibers and is approximately 20% lower for muons in the center or edges of the tile. For typical hadron calorimetry applications, we verified through simulation that this degree of non-uniformity would not adversely affect jet resolutions.

#### 4 Light yield dependence on tile parameters

The dependence of the light yield on variations in the design parameters was studied using cosmic ray data taken at the University of Maryland. Scintillator-based counters above and below the tile were used for a coincidence trigger. The tile light output was measured using a Hamamatsu R7600U-200-M4 photomultiplier tube. Fibers were connected to the tube using optical glue. Data was collected with a Tektronix MSO 5204 oscilloscope. A pair of plastic scintillating tiles were placed on the top and bottom of the tile to trigger the events. No attempt was made to select minimum ionizing muons. The muons thus are low energy and will produce more light than those studied at the CERN test beam.

We found an average of  $2.88 \pm 0.05$  p.e. for the nominal tile. A similar tile but without the mirroring yielded  $1.98 \pm 0.03$  p.e. with a reduction of a factor of 1.45. A tile with a 6 mm thickness of liquid, non-mirrored, yielded  $2.61 \pm 0.05$  p.e. with an increase over the 4 mm non-mirrored tile of a factor of 1.32. Figure 3 shows the collected charge (with arbitrary units) for the three different prototypes.

The light capture efficiency for different designs of the WLS support tubes was also studied. The aforementioned quartz2 configuration, a capillary filled with liquid WLS, was considered,

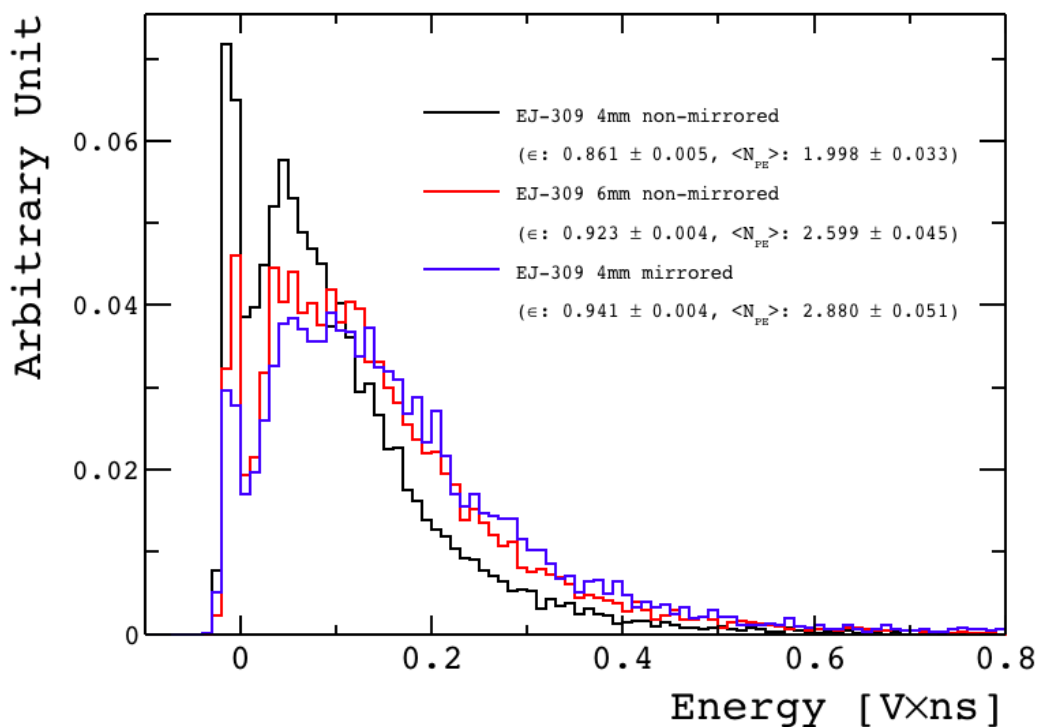

**Figure 3.** Comparison between the light output (arbitrary unit) of liquid scintillator tiles with different thickness and different treatment of the aluminum surface in contact with the liquid scintillator. The light output, proportional to the energy released by a particle traversing the scintillator volume, is measured in units of photodetector pulse area. The light is readout with the same 0.9 mm (O.D.) Y11 plastic WLS fiber. The three distributions are normalized to unit area.

since plastic WLS is susceptible to radiation damage. The capture efficiency of the WLS for the two different configurations depends crucially on the index of refraction of the surrounding media. For the quartz1 configuration, there is an air gap with an index of 1 between the fiber and quartz tube, while for the quartz2, the liquid WLS is bordered by quartz with an index of 1.6. The plastic and liquid WLS have very similar indices of refraction. In both cases, the shifted light propagates in the WLS, but the capture efficiency is higher for the lower index air. Figure 4 shows the charge collected (in arbitrary units) from cosmic muons for the two different configurations. The fraction of events in the pedestal, which is the Gaussian-shaped peak at low charge, can be used to calculate the fraction of muons producing at least one p.e. (light collection efficiency) and the mean number of p.e.'s per muon. With the assumption that p.e. counting follows Poisson statistics, we obtain that the estimate for mean number of p.e.'s per muon is  $-\ln(1 - \epsilon)$ , where  $\epsilon$  is the light collection efficiency. The light collection efficiency is 92% for the plastic WLS while it is 45% for the liquid. The light yield for the liquid is half that of the plastic. The light collection efficiency with the liquid could be improved if lower index quartz could be found.

Finally, we tested the performance of the same tile, 4 mm-thick, with a mirrored aluminum surface and the quartz1 configuration, for various thicknesses of the readout plastic WLS fiber. We tested three plastic fibers, with diameters of 0.5 mm, 0.9 mm, and 1 mm. The thicker the fiber thickness, the higher the efficiency and light output, as shown in figure 5.

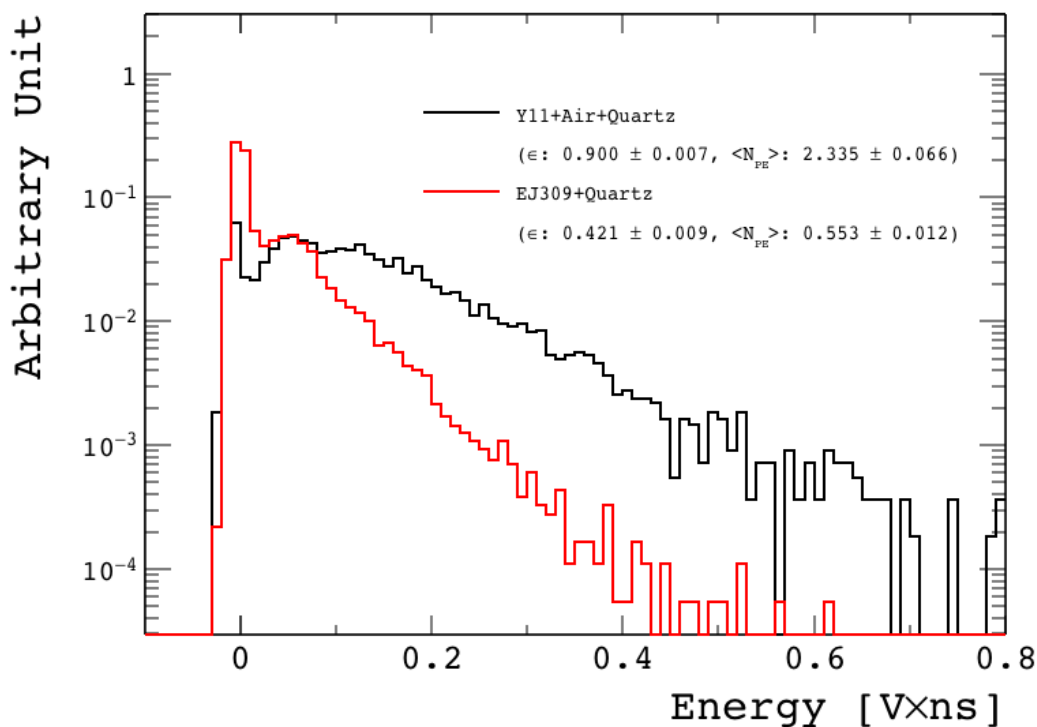

**Figure 4.** Comparison between the light output of a liquid scintillator tile equipped with a plastic WLS fiber, and a capillary filled with liquid WLS. The light output, proportional to the energy released by a particle traversing the scintillator volume, is measured in units of photodetector pulse area. The two distributions are normalized to unit area.

## 5 Radiation hardness tests

Several different tests were made using irradiations with a  $^{60}\text{Co}$  source at the University of Maryland.

A dark-glass vial containing 125 ml of liquid scintillator was irradiated with  $\gamma$ -rays to a dose of 50 Mrad, at a dose rate of 1 Mrad/hr. Figure 6 compares the integrated charge (in arbitrary units) from the same tile when filled with unirradiated liquid and irradiated liquid. The efficiency and light output from the two samples are consistent within the uncertainty, indicating that the light output of EJ-309 is radiation-tolerant to  $\gamma$ -ray irradiations.

We also irradiated a tile with the quartz3 readout configuration at a  $^{60}\text{Co}$  irradiation facility at Goddard Space Flight Center, to a dose of 30 Mrad at a dose rate of 3 krad/min. Some bulging of the container indicated that outgassing of EJ-309 may pose challenges for containers. We intend to investigate the outgassing mechanism and report measurements of this phenomenon in a future paper. We similarly intend to extend the irradiation plan to include neutron and proton irradiations, thus verifying if different damage mechanisms intervene.

## 6 Comparison with simulation and optimization

We use the GEANT4 [13] package to simulate the optics of our tile. GEANT4's optical package includes simulations of refraction, reflection, wavelength-shifting, and light attenuation. A variety

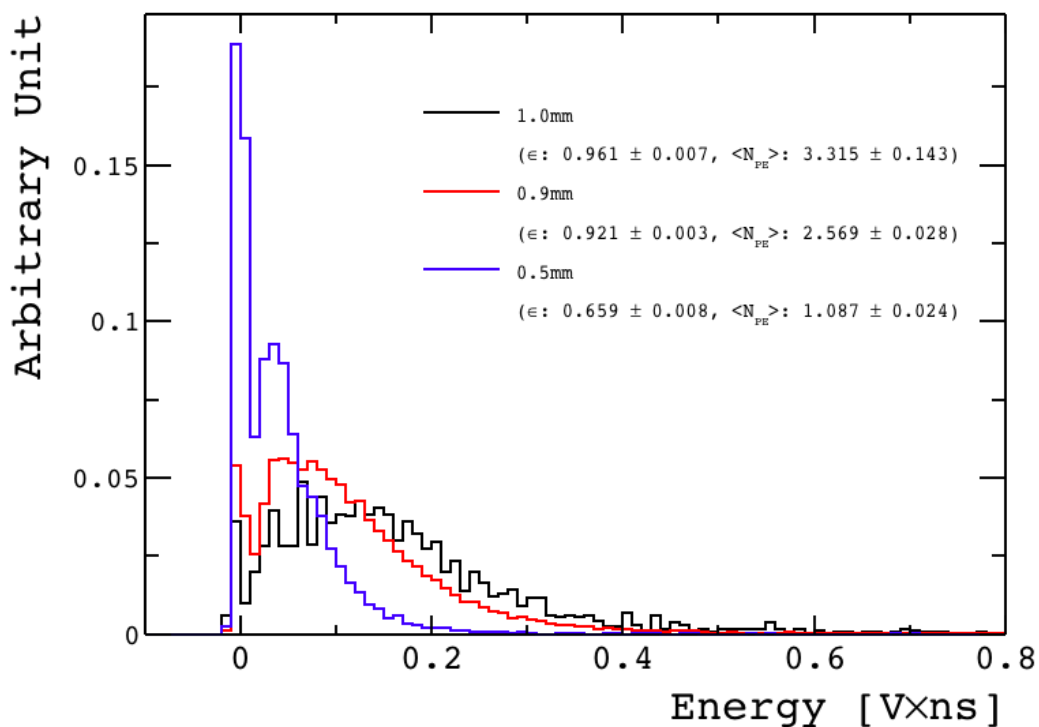

**Figure 5.** Comparison between the light output of liquid scintillator tiles readout with plastic WLS fibers with different thickness. The light output, proportional to the energy released by a particle traversing the scintillator volume, is measured in units of photodetector pulse area. The three distributions are normalized to have the same area of 1.

of options for the reflection are available. We used the “Specular Spike” option for the Al and an absorption length of 2 m for EJ-309. When simulating the WLS fiber, an air gap was included between the fiber cladding and the support tube, while no such gap exists for the simulation of the capillary. An index of refraction of 1.57 is used for EJ-309. The possibility of using a support tube with a high index of refraction was also considered; the material of choice was sapphire, with an index of refraction set to 1.77 in the simulation. For quartz, values between 1.46 and 1.55 were used. Photons are generated at random positions inside the liquid volume, with a spectrum corresponding to the emission spectrum of EJ-309.

As shown in figure 7 (top), we find the simulation reproduces the light collection non-uniformity when a reflectivity of 0.9 is used for the mirrored Al. We find that the light collection efficiency is a strong function of the reflectivity of the aluminum (figure 7, bottom).

We find the best light collection is obtained when the support tube has the lowest possible index of refraction for liquid WLS. The opposite is true for a fiber with an air gap (and plastic WLS). For a 1 mm diameter for the WLS, the light collection efficiency increases by a factor of 3.57 going from an index of 1.55 to 1.46 for liquids. Presumably this difference would decrease as the reflectivity of the Al increases. For a fiber with an air gap, the efficiency decreases by a factor of 1.42 going from an index of 1.77 to 1.46.



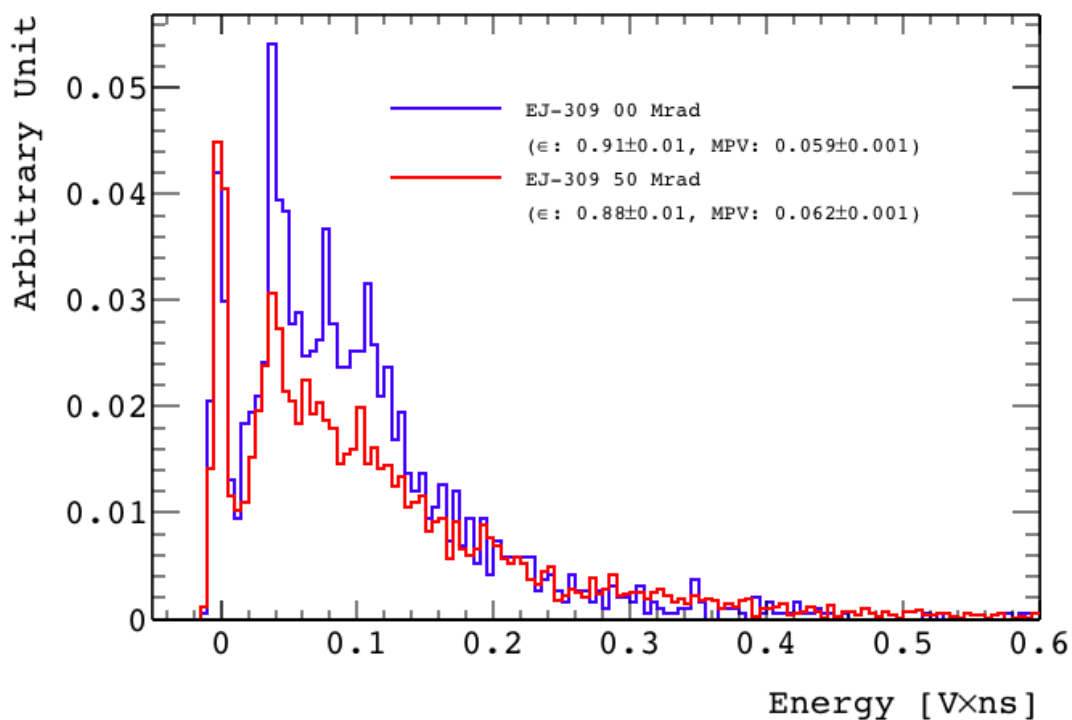

**Figure 6.** Comparison between the light output of a liquid scintillator tile filled with unirradiated (black) and irradiated (red) liquid scintillator. The light output, proportional to the energy released by a particle traversing the scintillator volume, is measured in units of photodetector pulse area. The two distributions are normalized to have the same number of events in the pedestal.

## 7 Conclusions

We presented results for various properties of a liquid scintillating tile using WLS fiber or capillary readout. For our nominal design,  $1.7 \pm 0.2$  p.e.'s were produced for minimum ionizing particles with a 20% non-uniformity. The light collection efficiency was adequate for calorimetry and the light output of EJ-309 was insensitive to radiation damage. We plan future study of the outgassing of EJ-309 as input to future designs.

## Acknowledgments

The authors would like to thank Randy Ruchti of Notre Dame for providing the capillaries and both Randy and Chuck Hurlbut of Eljen Technologies for advice in general on liquids, Yasar Onel's group at the University of Iowa for help with the test beam, and Victor Guarino of Argonne National Laboratory for help with preliminary mechanical designs. We would like to thank Eric Johnston from the Quattrone Nanofabrication Facility at the University of Pennsylvania for measuring the indices of refraction of our support tubes. The authors would like to thank the University of Maryland's Nuclear Reactor and Radiation Facilities group for assistance with the irradiations. We would like to thank the University of Maryland FabLab for help with fiber sputtering. We would also like to thank the staff at the irradiation facility at Goddard Space Flight center. This work was supported in part by U.S. Department of Energy Grants DE-SC-0010072 and DE-SC-0014088.

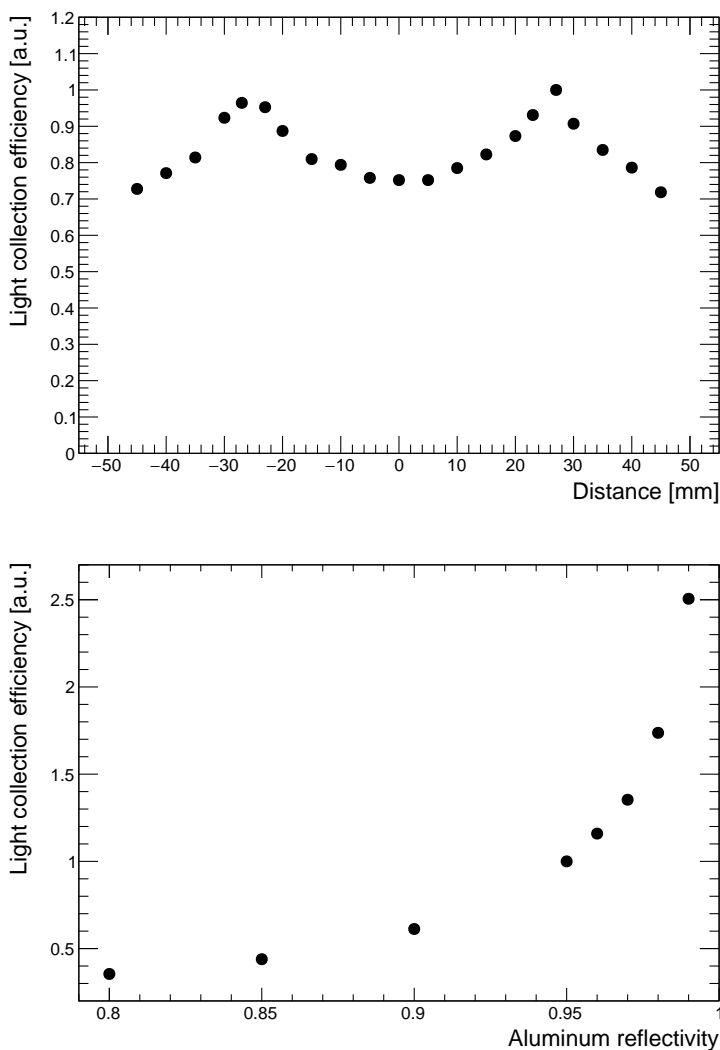

**Figure 7.** (Top) Ratio of light yield to maximum light yield from a simulated tile as a function of the distance perpendicular to the support tubes, normalized to the efficiency at the position of the support tubes. (Bottom) Light collection efficiency vs. aluminum reflectivity, normalized to a reflectivity of 0.95.

## References

- [1] S. Aota et al., *A scintillating tile/fiber system for the CDF plug upgrade EM calorimeter*, *Nucl. Instrum. Meth. A* **352** (1995) 557.
- [2] F. Ariztizabal et al., *Construction and performance of an iron-scintillator hadron calorimeter with longitudinal tile configuration*, *Nucl. Instrum. Meth. A* **349** (1994) 384.
- [3] S. Abdullin et al., *Design, performance, and calibration of CMS hadron-barrel calorimeter wedges*, *Eur. Phys. J. C* **55** (2008) 159.
- [4] CMS collaboration, *The CMS hadron calorimeter project: technical design report*, [CERN-LHCC-97-031](#) (1997).
- [5] V. Hagopian and I. Daly, *Radiation damage of fibers*, *AIP Conf. Proc.* **450** (1998) 53.

- [6] A. Byon-Wagner, *Radiation hardness test programs for the SDC calorimeter*, *Radiat. Phys. Chem.* **41** (1993) 263.
- [7] C. Zorn, S. Majewski, R. Wojcik, C. Hurlbut and W. Moser, *Preliminary study of radiation damage in liquid scintillators*, *IEEE Trans. Nucl. Sci.* **37** (1990) 487.
- [8] J. Klein, J. Gresset, F. Heisel and G. Laustriat, *Effets des rayonnements- $\gamma$  sur les caracteristiques des scintillateurs organiques*, *Int. J. Appl. Radiat. Isot.* **18** (1967) 399.
- [9] I. Berlman, *The effect of massive  $^{60}\text{Co}$  doses on the light output of a scintillator solution*, *Radiological Physics Division Semiannual Report for July through December*, p. 7 (1957).
- [10] L. Bignell et al., *Measurement of radiation damage of water-based liquid scintillator and liquid scintillator*, *2015 JINST* **10** P10027.
- [11] J. Marchant et al., *Liquid-based scintillators for particle physics*, *IEEE Nucl. Sci. Symp. Conf. Rec. (NSS/MIC 2010)* (2010) 10.
- [12] T. Shaw et al., *Front end readout electronics for the CMS hadron calorimeter*, *IEEE Nucl. Sci. Symp. Conf. Rec. (NSS/MIC)* (2002) 194.
- [13] GEANT4 collaboration, S. Agostinelli et al., *GEANT4 — A simulation toolkit*, *Nucl. Instrum. Meth. A* **506** (2003) 250.