

DESIGN CONCEPT AND PARAMETERS OF A 15 T Nb₃Sn DIPOLE DEMONSTRATOR FOR A 100 TEV HADRON COLLIDER*

A.V. Zlobin[#], N. Andreev, E. Barzi, V.V. Kashikhin, I. Novitski, FNAL, Batavia, IL 60510, U.S.A.

Abstract

FNAL has started the development of a 15 T Nb₃Sn dipole demonstrator for a 100 TeV scale hadron collider. This paper describes the design concept and parameters of the 15 T Nb₃Sn dipole demonstrator. The dipole magnetic, mechanical and quench protection concept and parameters are presented and discussed.

INTRODUCTION

Hadron Colliders (HC) are the most powerful discovery tools in modern high energy physics. Interest to a HC with energy above the LHC reach gained further momentum in the strategic plans recently developed in the U.S., Europe and China [1]-[3]. To build a ~100 TeV HC in a ~100 km tunnel, ~15 T dipoles operating at 1.9 or 4.5 K with 15-20% margin are needed. A nominal operation field up to 15-16 T can be provided by the Nb₃Sn technology. A practical demonstration of this field level in accelerator-quality magnets and a substantial reduction of magnet costs are key conditions for the realization of such a machine.

The main challenges for 15 T Nb₃Sn magnets include significantly stronger Lorentz forces and larger stored energy. The stronger forces generate higher stresses in the coil and mechanical structure and, thus, may need stress control to maintain them below 150 MPa, which is acceptable for brittle Nb₃Sn. The larger stored energy leads to further complications in the magnet quench protection.

FNAL has started the development of a 15 T Nb₃Sn dipole demonstrator for a 100 TeV scale HC based on the optimized “cos-theta” coil design. As a first step, the existing 11 T dipole, developed for LHC upgrades [4], will be modified by adding two layers to achieve the field of 15 T in a 60 mm aperture. Then, to increase the field margin the innermost 2-layer coil will be replaced with an optimized coil using the conductor grading approach. This paper describes the design concept and parameters of the 15 T Nb₃Sn dipole demonstrator.

MAGNET DESIGN STUDIES

The coil width w , needed to generate the bore field $B0_{max}$, could be estimated from the following equation for the cos-theta dipole coil with an azimuthal angle of 60 degrees

$$B0_{max} = \frac{\sqrt{3} \mu_0}{\pi} \cdot \lambda J_c(B_{max_coil}) \cdot w$$

where λ is the fraction of superconductor in a coil ($\lambda=0.25$) and $J_c(B_{max_coil})$ is the superconductor critical current density at B_{max_coil} in the coil (usually B_{max_coil} is ~ 1.05 $B0_{max}$). Thus, to achieve $B0_{max}=15$ T using Nb₃Sn strands with a realistic $J_c(15 T)$ of 1500 A/mm², the coil

width w has to be ~60 mm. When using the same 15 mm wide cables as in the FNAL 11 T dipole [4], this requires a 4-layer coil design.

The chosen coil aperture of 60 mm, convenient for re-using the 11 T dipole coils, provides also enough room for a beam screen to intercept the large synchrotron radiation expected in a 100 TeV scale HC. To reduce the demonstrator cost, a collarless design with 2 mm thick spacer between the coil and the yoke was adopted. The standard thickness of the insulation between the coil layers as well as the coil ground insulation thickness are 0.5 mm. The mid-plane insulation is 0.2 mm.

Several four-layer coils were designed using two cables with a width of 15 mm and different thickness. The cable parameters are listed in Table 1. The cables use 1.0 and 0.7 mm Nb₃Sn strands with a critical current density $J_c(15T;4.2K)$ of 1500 A/mm² and a nominal Cu/SC ratio of 1.13. Nb₃Sn cables with these or similar parameters have already been developed at FNAL and used in HFDA and 11 T dipole models [5], [6].

Table 1: Reacted cable parameters.

Parameter	Cable 1	Cable 2
Number of strands	28	40
Mid-thickness, mm	1.870	1.319
Width, mm	15.10	15.10
Keystone angle, degree	0.805	0.805

The coil cross-sections were optimized using the ROXIE code [7]. The goal was to achieve a maximum dipole field of 15 T or higher at 4.3 K and geometrical field harmonics below the 10⁻⁴ level at $R_{ref}=17$ mm, reduce the coil volume and inductance, and control the coil azimuthal stress. Five 4-layer coil designs with graded coils were analyzed. The main parameters of these coils are summarized in Table 2. The coil cross-sections with relative field errors in the aperture (dark blue area) and numbers of turns per coil layer N_L are shown in Fig. 1.

Table 2: Coil parameters.

Parameter	Coil design				
	4L-1	4L-2	4L-3	4L-4	4L-5
N_{L1}	15	17	18	18	18
N_{L2}	25	25	25	25	26
N_{L3}	47	40	39	36	33
N_{L4}	54	43	38	35	32
N_{tot} coil	141	125	120	114	109
S_{coil} , cm ²	31.4	28.4	27.5	26.3	25.4
$B0_{max}(4.3K)$, T	16.3	16.1	16.0	15.8	15.7
$I_{max}(4.3K)$, kA	9.89	10.34	10.52	10.84	11.10
L , mH/m	39.9	33.8	31.5	28.7	26.5
$W(B_{max})$, MJ/m	1.95	1.81	1.74	1.69	1.63

* Work supported by Fermi Research Alliance, LLC, under contract No. DE-AC02-07CH11359 with the U.S. Department of Energy

[#] zlobin@fnal.gov

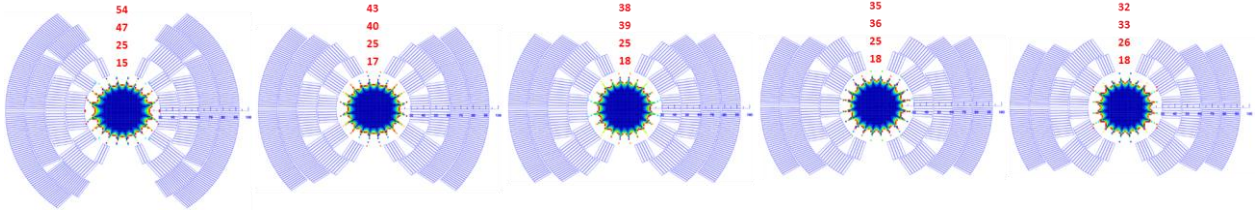

Figure 1: Coil cross-sections with relative field errors in the aperture (dark blue area).

All the coils, except for 4L-1, have 7-block design with two spacers in the innermost layer and one spacer in layer 2 per quadrant. A good field quality was achieved in all the coils. To reduce inductance, stored energy and coil volume, the number of turns in the two outermost layers was gradually decreased providing also a reduction of the azimuthal Lorentz forces in coil mid-planes. To achieve the required field quality a few additional turns were added to the innermost layer, and the wedge cross-section and positions were optimized.

The maximum bore field BO_{max} and the ratio of maximum bore field to the coil cross-section area BO_{max}/S_{coil} for five studied coil designs are plotted in Fig. 2. Whereas BO_{max} reduces by only 3% in the 4L-5 design with respect to the 4L-1 design the S_{coil} drops by almost 25% demonstrating a higher efficiency for the 4L-5 design.

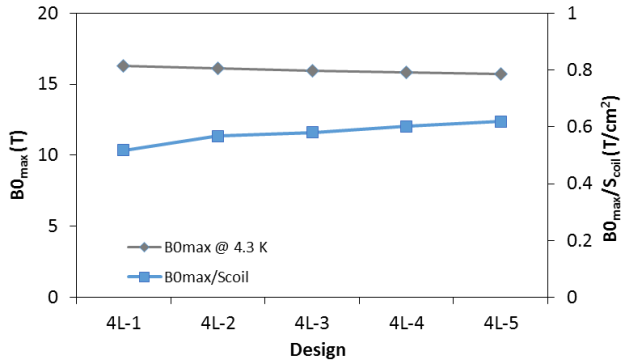

Figure 2: Maximum bore field and ratio of the bore field to the coil cross-section area for the studied coil designs.

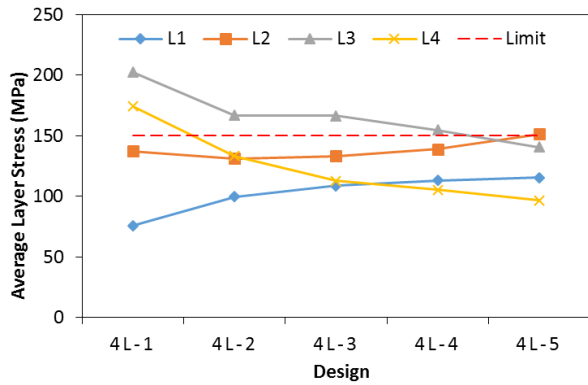

Figure 3: Average azimuthal stress in the coil mid-plane at the maximal bore field for the studied coil designs.

The average azimuthal stress σ_{av} in the coil midplane in each layer was estimated using the following formula

$$\sigma_{av} = \frac{1}{w_L} \cdot \sum_{n=1}^{N_L} F_{\theta n}$$

where w_L is the layer width, N_L is the number of turn in the layer and $F_{\theta n}$ is the azimuthal component of Lorentz force in the n -th turn. The average azimuthal stress in the coil mid-planes at the maximal bore field for the five studied coil designs is shown in Fig.3. The horizontal dashed line represents the maximum allowed stress level of 150 MPa for the brittle Nb₃Sn coils. It can be seen that only designs 4L-4 and 4L-5 provide the acceptable average stress level in the coil.

Quench protection of accelerator magnets is provided by dumping the magnet stored energy in the large coil volume using quench protection heaters (PH). In the conservative adiabatic case a maximum value of the average coil quench temperature T_{max} could be estimated using the following equation

$$W_m = N_{qt} \cdot \int_{T_{cs}}^{T_{max}} C_{pt}(T) dT$$

where W_m is the magnet stored energy, N_{qt} is the number of turns quenched by protection heaters, $C_{pt}(T)$ is the turn specific heat and T_{cs} is the current sharing temperature. The average coil quench temperature T_{max} under protection heaters at the maximal bore field for the five studied coil designs is shown in Fig. 4. The horizontal dashed line represents the T_{max} limit of ~300 K for accelerator magnets. To protect a magnet with only one PH (two PH circuits are used for redundancy) in all the studied designs both outermost layers have to be quenched. The coil quench temperature in the nominal case with two protection heaters is less than 200 K at bore fields of ~16 T.

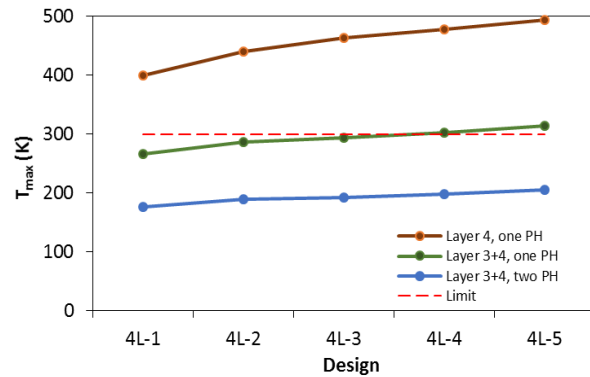

Figure 4: Average coil quench temperature at maximal bore field for the studied coil designs.

15 T DEMONSTRATOR DIPOLE DESIGN

The main objectives of this magnet are demonstration of the 15 T field level and study of the magnet quench performance and margins, quench protection (heater efficiency, quench propagation, coil quench temperature, etc.), and field quality (geometrical harmonics, coil magnetization, iron saturation, dynamic effects).

Based on the design studies described above, coil design 4L-5 was selected for the 15 T dipole demonstrator. To optimize the program the two outermost layers will be first assembled and tested with the available 60-mm coils used in the 11 T dipole models [4], and then with the optimized inner-layer coils. The cross-sections of the optimized and “interim” coils are shown in Fig. 5.

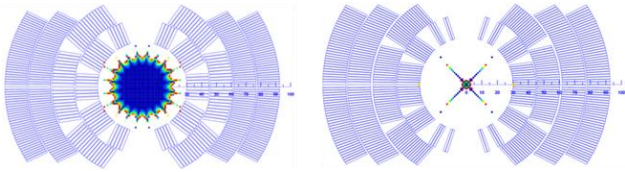

Figure 5: Cross-sections of optimized (left) and “interim” (right) coils with the field quality in coil bore.

The cross-section of the 15 T dipole demonstrator cold mass is shown in Fig. 6. It features four-layer Nb₃Sn coils, which are supported by a vertically split iron yoke, two stainless steel clamps, and a thick stainless steel skin. The 15 T dipole demonstrator will use the existing bolted skin with an inner diameter of 400 mm used in several FNAL’s dipole and quadrupole models [8]. The cold-mass length is ~1 m long. The maximum cold mass transverse size is ~610 mm and is limited by the inner diameter of the test dewar.

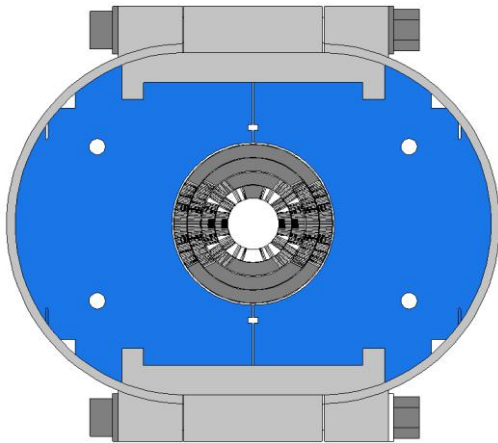

Figure 6: Cold mass cross-section with the 11 T dipole coil.

The coil assembly, surrounded by 2 mm stainless steel spacers, is placed in between the two half-yokes and clamped with two clamps. The bolted skin is pre-tensioned under the yoking press to provide a coil pre-stress at room temperature that is sufficient to keep the coil pole turns under compression up to the maximum design field of ~15 T. Two thick end plates bolted to the outer shell restrict the longitudinal coil motion under axial Lorentz forces. Quench protection heaters composed of stainless steel

strips are placed between the 2nd and 3rd coil layers and on the coil outer layer.

The calculated 2D design parameters of the 15 T dipole demonstrator are reported in Table 3. In the interim design with the 11 T dipole coils the maximum bore field at 4.3 K is 14.7 T, whereas in the optimal graded design it reaches 15.7 T. Reducing the temperature to 1.9 K will allow increasing the maximum bore field by ~10% with respect to the values shown in Table 3.

Table 3: Magnet design parameters at 4.3 K.

Parameter	Interim	Optimal
SS bore field, T	14.73	15.70
Short-sample current I_c , kA	8.84	11.10
Inductance, mH/m	33.4	26.5
Max stored energy, MJ/m	1.30	1.63
Max F_x per quadrant, MN/m	6.20	7.49
Max F_y per quadrant, MN/m	-3.47	-4.24

CONCLUSIONS

Cost-effective dipole magnets with nominal fields of ~15 T based on the Nb₃Sn technology are needed for a future 100 TeV scale HC. An early demonstration of the accelerator quality dipole of this class is a key milestone to prove feasibility of this machine. FNAL is developing a single-aperture 15 T Nb₃Sn dipole demonstrator for a HC based on a 4-layer graded cos-theta coil with 60 mm aperture and cold iron yoke. The engineering design of the magnet and fabrication tooling is nearly complete. The cold tests are planned in the first quarter of 2016.

REFERENCES

- [1] “Building for Discovery: Strategic Plan for U.S. Particle Physics in the Global Context,” P5 Report, http://science.energy.gov/~media/hep/hepap/pdf/May%202014/FINAL_P5_Report_053014.pdf
- [2] Future Circular Collider Study Kickoff Meeting, Geneva, Switzerland, February 12-14, 2014, <http://indico.cern.ch/event/282344/timetable/#20140212>
- [3] CEPC/SppC study in China, <http://indico.cern.ch/event/282344/session/1/contribution/65/material/slides/1.pdf>
- [4] A.V. Zlobin et al., “11 T Twin-Aperture Nb₃Sn Dipole Development for LHC Upgrades,” IEEE Trans. on Appl. Supercond., v. 25, Issue 3, June 2015, 4002209.
- [5] N. Andreev et al., “Development of Rutherford-type Cables for High Field Accelerator Magnets at Fermilab”, IEEE Trans. on Appl. Supercond., v. 17, Issue 2, June 2007, p. 1027.
- [6] E. Barzi et al., “Development and Fabrication of Nb₃Sn Rutherford Cable for the 11 T DS Dipole Demonstration Model”, IEEE Trans. on Appl. Supercond., v. 22, Issue 3, June 2012, 6000805.
- [7] ROXIE 10.2, <http://cern.ch/roxie>.
- [8] A.V. Zlobin, “Status of Nb₃Sn Accelerator Magnet R&D at Fermilab”, CERN Yellow Report CERN-2011-003, pp. 50-58. [arXiv:1108.1869].