

AN UPDATE FOR THE MuCOOL TEST AREA

A. Bross¹, M. A. Cummings³, C. Darve¹, S. Ishimoto², A. Klebaner¹,
A. Martinez¹, B. Norris¹, and L. Pei¹

¹Fermi National Accelerator Laboratory
Batavia, IL, 60500, USA

²High Energy Accelerator Research Organization (KEK)
Tsukuba, Ibaragi, 305-0801, Japan

³Northern Illinois University
DeKalb, IL, 60115, USA

ABSTRACT

Construction of a new facility known as the MuCool Test Area (MTA) has been completed at Fermi National Accelerator Laboratory. This facility supports research in new accelerator technologies for future endeavors such as a Neutrino Factory or Muon Collider. During the summer of 2004, an initial set of tests was completed for the filling of a convection-style liquid hydrogen absorber designed by KEK. The absorber contained 6.2 liquid liters of hydrogen and was tested for a range of heating conditions to quantify the absorber's heat exchanger performance.

Future work at Fermilab includes the design, construction, and installation of a forced-flow absorber to be used with other components built to investigate the properties of a muon ionization cooling channel. A Tevatron-style refrigerator/compressor building is to be operational by spring of 2006 in support of the absorber tests and also to provide 5-K helium and liquid nitrogen to a 5-T solenoid magnet, an active element of the future test apparatus. The refrigerator will be configured in such a manner as to meet the 5 K and 14-20-K helium needs of the MTA.

This paper reviews the challenges and successes of the past KEK absorber tests as well as looks into the future cryogenic capabilities and intentions of the site.

KEYWORDS: hydrogen, absorbers, safety, controls

PACS: 07.20.Mc

INTRODUCTION

Research related to the development of a future Muon Collider or Neutrino Factory has led to engineering efforts in the area of the cooling of muons to reduce beam emittance [1]. Energy absorption using liquid hydrogen (LH_2) is being studied. The beam is "cooled" when passing through the LH_2 by energy loss and its emittance is reduced; both transverse and longitudinal momentum is lost. In the final muon cooling channel, accelerating RF cavities immediately follow the absorber in the beam line. Emittance reduction can be maximized by using an absorber material with low Z. Each absorber has beam windows whose material is also selected based on the need to reduce Coulomb scattering. The maximization of emittance reduction drives the use of LH_2 for absorption and aluminum for windows.

At Fermilab, under the direction of the MuCool Collaboration, two types of absorber schemes are being tested - a convection style absorber and a forced-flow absorber [2-3]. A convection absorber was designed and built by KEK and initially tested at the Fermilab MuCool Test Area (MTA) in the summer of 2004. This test used a dewar-fed helium system as the cooling mechanism since the 500 W, nominal 14-K refrigeration system was yet to be installed. This paper discusses results from those initial tests as well the plans for the second phase of convection tests envisioned for fall 2005. The forced flow absorber uses a hydrogen pump and a closed-loop cooling scheme. It is our goal to install this component into a beam line at the MuCool Test Area (MTA) by the summer of 2006.

KEK CONVECTION ABSORBER TEST 2004

The very first use of cryogenics at the MTA occurred in the summer of 2004 [3-4]. This first test led to the successful liquefaction of 6.2 liters of hydrogen in the KEK LH_2 convection absorber. FIGURES 1 and 2 show pictures of the KEK cryostat and absorber.

Because the final helium refrigeration system was not installed, this test required the use of 500 liquid liter helium dewars located outside of the experimental hall, and transferring the needed helium cooling to a heat exchanger within the KEK cryostat via a 25 meter long transfer tube. (The physical constraints of the building layout required us to separate the absorber and the supply dewars by this long distance. Therefore, the helium cooling capacity available to the LH_2 absorber was limited since 23 W of refrigeration had to be used for transfer line heat leak). Initially we attempted to pressurize the helium dewars, transferring the helium out of the dewars to the absorber cryostat while also using an in-line electrical heater to control the input temperature of the helium at the absorber.



FIGURE 1. KEK cryostat installed.



FIGURE 2. KEK absorber volume.

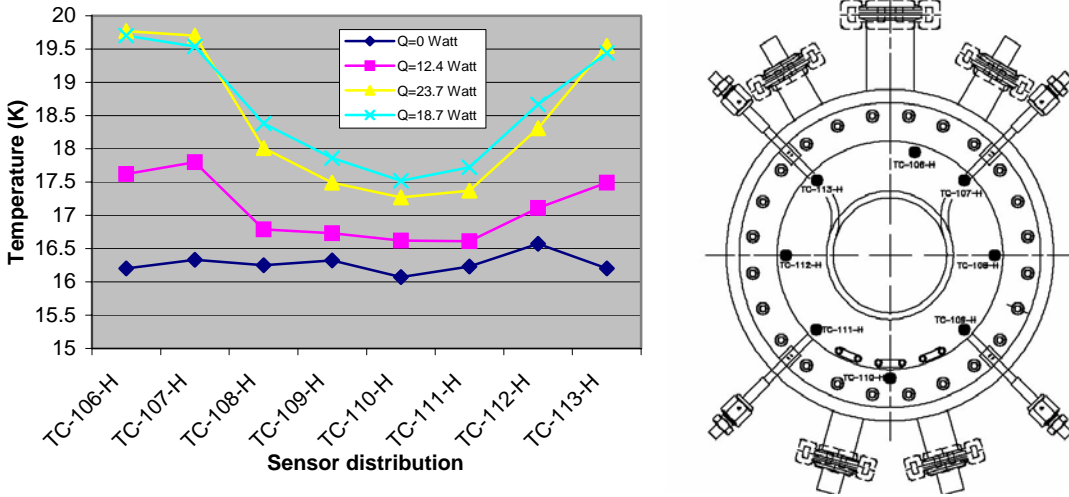

FIGURE 3. Left: temperature distribution within the KEK hydrogen bath with varying heat deposition ($T_0 = 16.3$ K, $P_0 = 0.15$ MPa). Right: the KEK cryostat showing physical locations of Pt-Co sensors.

After a long period of struggling with two-phase helium transfer line instabilities leading to unstable LH₂ cooling/liquefaction, we modified our scheme by placing heaters directly in the supply helium dewars in order to boil the liquid phase and transfer only cold gas. Once this was accomplished, we were able to liquefy hydrogen in a manageable fashion.

We varied the LH₂ bath temperature by varying the helium cooling capacity. This cooling capacity was regulated by means of the dewar heater and the position of flow control valves located downstream of the absorber. Flow meters, pressure transducers and temperature sensors allowed us to monitor the cooling. The liquid hydrogen bath temperature was monitored using eight platinum-cobalt (Pt-Co) temperature sensors. While monitoring these Pt-Co devices, we selected a "nominal" bath temperature, which was determined as the average of the eight sensors. Heat was then added to the bath by introducing 300-K helium gas, flowing through tubing routed in the center of the hydrogen volume. This heating was to simulate beam loading. The maximum heat load deposited was 23.7 W (+/- 1.5%). FIGURE 3 shows the temperature distribution in the bath with a starting bath temperature of 16.3 K under varying heat deposition. Twenty different configurations similar to this one were tested [4]. FIGURE 4 summarizes test results through a variety of temperature and applied heat load ranges.

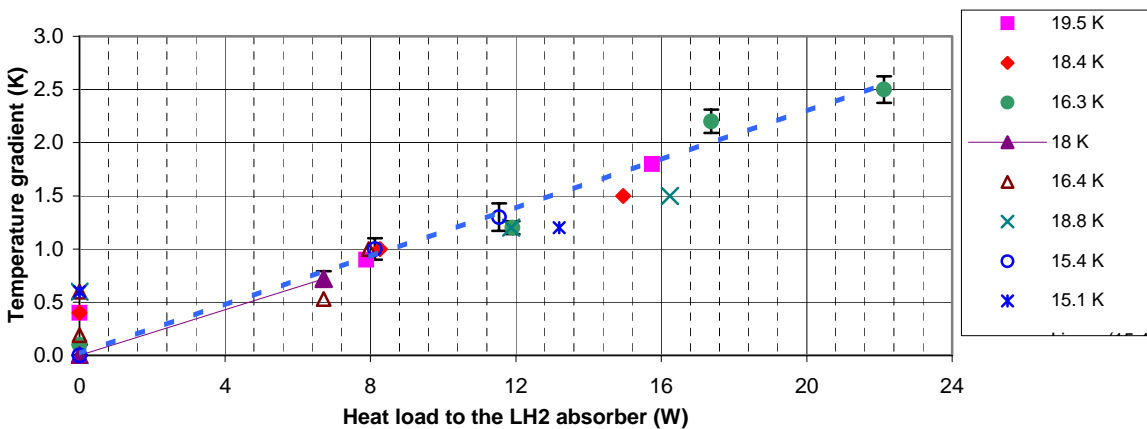

FIGURE 4. Maximum temperature gradient ((TC-106-H) - (TC-110-H)) versus applied heat for several LH₂ absorber bath temperatures.

FUTURE TEST FOR KEK

A second round of tests is planned for the KEK cryostat at Fermilab before the end of 2005. KEK desires to quantify the highest heat loading achievable for this convection-type LH₂ absorber design. This test shall provide a better understanding of the heat transfer coefficient for the LH₂ absorber internal heat exchanger and shall provide a more reliable temperature mapping of the LH₂ absorber volume. Some modifications will be required before the test.

First, the 25 m of transfer line between the dewar fed system and the absorber will be reduced to 10 m. This should reduce the known static heat leak of this transfer system from 23 W to approximately 9 W. This provides a much longer testing period with the available helium supply, as well as allows us to depose more heat into the absorber and better quantify its performance. In the first test, long periods of instability resulted because of high helium usage and the need to often bring a new 500 liter dewar 'on-line', resulting in rapid hydrogen boiling and frequent venting of the hydrogen vessel.

Second, KEK experimenters desire to modify the absorber heating scheme. The gaseous helium coils will be removed and an electrical heater shall be installed. A heater design has been developed but still requires Fermilab Safety approval. The proposed standard cartridge heater will be inserted inside of a finned aluminum (A5083) exchanger. Heat would be transferred through the fins to the LH₂ absorber volume; no electrical or ignition source contact with hydrogen is to be allowed. Further, a thermometer will be installed on the surface of the finned exchanger and interlocked with the heater power supply. Should temperature rise to unacceptable levels, the electrical power to the heater shall be shut-off.

Third, KEK desires to install Cernox 1050SD's as replacement for the Pt-Co sensors and will also install a liquid level probe in the LH₂ bath.

CONSTRUCTING A HYDROGEN FACILITY AT FERMILAB

All phases of construction and experimental development of the MTA Experimental Hall have been reviewed by a Cryogenic Safety Panel with a special emphasis on hydrogen safety issues. The MTA Experimental Hall is classified in accordance with NEC standards as a Class I, Division 2, Group B environment. All systems installed in the Hall in support of this work must adhere to this classification. A short list of standards we have been required to use follows:

- "Guidelines for the Design, Review and Approval of Liquid Cryogenic Targets" - a Fermilab internal guideline;
- National Electrical Code (NEC);
- Fermilab ES&H Safety Manual as pertaining to cryogenics, pressure vessels, etc.;
- National Fire Protection Agency (NFPA) code as applying to intrinsic safety.

A number of engineering solutions were necessary for us to meet the standards for hydrogen operation at Fermilab. Some comments and a short list follows:

- Fermilab Safety requirements mandated that we follow these specific rules: the hydrogen vessel had to have redundant relief valves, our vessel had to be limited to a maximum working pressure of 0.16 MPa, H₂ detectors had to be incorporated into the Experimental Hall and integrated into an automated response scheme, an excess

flow valve had to limit the GH_2 supply flow; and a 5 m area was established in which all ignition sources had to be made intrinsically safe or placed in a shunt trip circuit.

- A special Safety PLC was used as the central controls package and equipment interlock for the experiment. We selected QUADLOG® sold by Siemens-Moore. All cryogenic sensors, controls, and safety devices such as hydrogen detection or ODH monitoring communicated to QUADLOG®. The configuration was reviewed by a special controls committee to address issues of life safety.
- A purged electrical enclosure was installed in the Hall at the location of the KEK experiment. This box housed all electrical ignition sources that could not easily or cost-effectively be made intrinsically safe. This box was then purged with gaseous nitrogen to a constant pressure as defined by NFPA standards for purged enclosures. Differential pressure was measured and transmitted to our QUADLOG® Safety PLC for constant monitoring. In the event of a loss of purge pressure, the QUADLOG® Safety PLC initiated a power down of all devices contained in the enclosure and initiated a hydrogen shutdown. Any hydrogen in the KEK cryostat was vented and the supply gas to the vessel was stopped by closing an actuator.
- A 21 m³ buffer tank was placed on the MTA site and connected to the vacuum space of the hydrogen cryostat. Fermilab Safety guidelines mandate that in the event of a leak, all hydrogen must be contained in some form of "secondary containment." Here, any internal cryostat leak is collected in this tank. The tank and accompanying pipe connection were kept under vacuum at all times. Vacuum pressures in the KEK cryostat and the tank were constantly monitored via QUADLOG®. In the event of a rise in vacuum, QUADLOG® initiates a system shutdown.
- All electrical cables in the Hall for controls and sensors required us to use MC type cable or PLTC cable supported by cable tray.
- A large set of operational procedures was written and approved for filling the cryostat with hydrogen, accessing the experimental hall with hydrogen present, and addressing emergency scenarios.

THE FUTURE CRYOGENIC FACILITY

Work is presently underway to install the required refrigeration system for long-term MuCool research. A special building, divided into 2 rooms - a compressor room and a refrigerator room, will house all the rotating machinery, satellite heat exchangers, and controls for support of this research. A transfer line system will connect the refrigeration complex to the Experimental Hall.

The compressor room houses two 300-KW 2-stage oil injected screw compressors made by Sullair. A 34,000 liter helium storage tank is used for gas helium storage and supply. Liquid nitrogen is stored in a horizontal storage dewar. A standard Tevatron satellite heat exchanger has been moved from a previous Fixed Target beam line location and installed at MTA. An outside piping contract was completed for the installation of the piping for the compressor/refrigerator complex in August of 2005. Electrical and controls installation will begin in late fall 2005 with startup of the facility anticipated in spring 2006.

Dual Mode Usage

The helium refrigeration system must support two operational temperature ranges. Besides the forced flow absorber which will require helium cooling at nominal 14-K temperatures, the plant will also be required to "batch fill" a 5-T solenoid magnet containing both liquid helium and liquid nitrogen pots. The overall layout is shown in FIGURE 5.

A five-circuit transfer line is being designed and constructed at Fermilab. The circuits are a 14-K supply, 20-K return, 5-K supply, 5-K return and a LN₂ supply. The 14-K supply and 20-K return circuits are integral to the hydrogen cooling while the 5-K supply is for "batch-filling" the MTA solenoid. (At present the 5-K return is not used but has been designed into the transfer line for future 5-K needs.) As of this writing it is not clear as to the exact "around the clock" operating plan for running the hydrogen system. Scheduling of beam on and off periods will be unknown until the facility is fully operational. Further, at all times we will desire to maintain the solenoid in a superconducting state.

In response to these unknowns, we have taken an approach to allow the refrigeration system to switch from 14-K to 5-K mode and back again. Tests done at Fermilab's Cryogenic Test Facility (CTF) have shown that we can switch from 14-K to 5 K in about 2.5 hours [5]. The CTF system is virtually identical to the MTA facility including the use of a satellite refrigerator, a 5.0-cm piston (gas) expander, and a 7.5-cm piston (liquid) expander. In the case where absorber physics requires the plant to be operated in 14-K mode for extended periods, the design incorporates the use of 500-l mobile dewars to batch fill the MTA solenoid. Mobile 500-l dewars can be used as well. The total amount of liquid helium needed to fill the solenoid is 300-l.

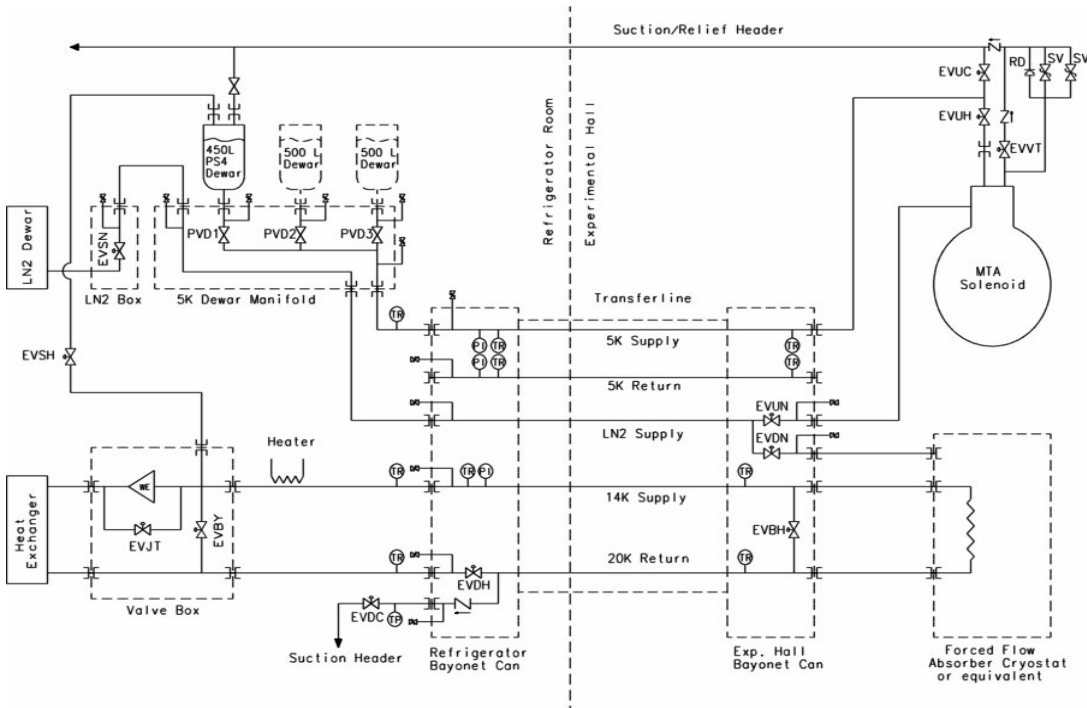

FIGURE 5. Overall scheme of the MTA refrigeration, including support of the 5-K helium needs for the MTA solenoid, and the 14-K system for absorber experiments.

Requirements for Future Absorber Cooling

Hydrogen cooling is accomplished in the future forced-flow absorber loop via a He/H₂ heat exchanger. The main requirement of the He/H₂ heat exchanger is to maintain the temperature difference in the LH₂ to within a density fluctuation of +/- 2.5%. Since the freezing and liquefaction points of hydrogen at normal pressure are 13.95-K and 20.27-K, a future operating point that meets these conditions and the needs of the power dissipation will need to be found.

In order to quantify the available refrigeration available in the 14 K mode, CTF was setup in a mode of operation identical to the proposal for MTA. Tests show that with a 4-K differential across the heat exchanger, approximately 550 W of cooling are available. With a differential of 3-K the cooling power is 448 W. Flow rates ranged from 24.7 g/s to 27.5 g/s.

In the actual MTA configuration, a trim heater will be installed on the outlet of the liquid engine. The heater will be used to 'trim' any temperature fluctuations from the helium supply. Regulation of this heater will provide the proper helium inlet temperature to the He/H₂ exchanger to maintain the required density specification. Also, the absorber hydrogen system will need to be stable whether the future beam is on or off. A sudden loss of beam would be seen on the helium system as an immediate loss of heat load causing the helium temperature from the absorber to quickly drop. Instrumentation will be established to provide the beam status to the cryogenic controls, and allowing the trim heater and a heater imbedded in the hydrogen loop to ramp up or ramp down correspondingly.

FIGURE 6 displays the different test set-ups in the MTA experimental hall. Further description of the MTA facilities is detailed in [6].

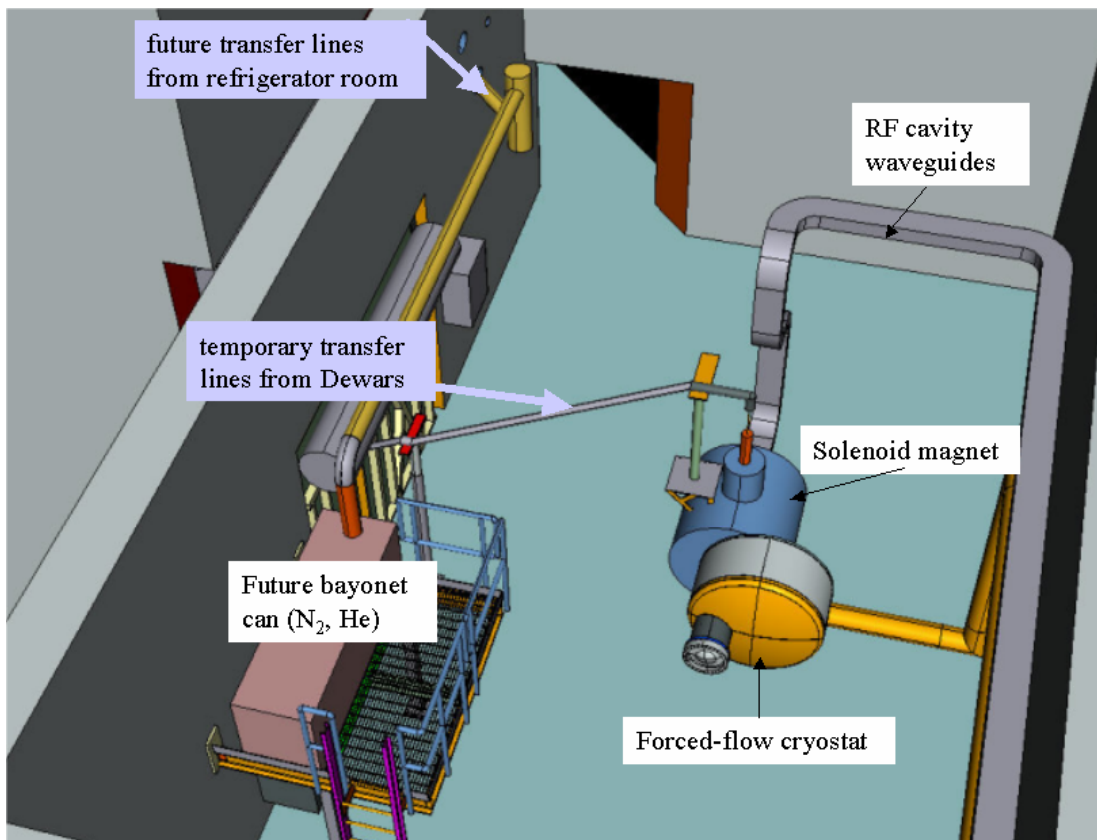

FIGURE 6. Layout of MTA Experimental Hall.

FORCED FLOW ABSORBER DESIGN

The proposed LH₂ forced-flow absorber system shall accommodate more heat deposited than the convection type. Using the full capacity of the MTA final helium refrigeration system, we expect to remove greater than 300 W of heat from the LH₂ absorber, while circulating LH₂ through the 25-l closed loop. The LH₂ absorber is sub-cooled to 17-K at 0.12 MPa in order to maximize its thermo-hydraulic performance. Nucleate boiling is allowed, while limiting the LH₂ density fluctuations to +/- 2.5 %.

The conceptual design of the forced-flow system was completed in 2002 [7-8]. The LH₂ loop is composed of a 6.9-l LH₂ absorber, a LH₂ pump, a He/H₂ counter flow heat exchanger and a heater to stabilize helium refrigeration. The LH₂ loop is contained in a vacuum vessel, which is inserted in the bore of the 5 T solenoid magnet. Pressure relief valves and control valves are chosen to comply with the safety standards listed earlier. The vacuum volume is connected to the MTA vacuum buffer tank described above and which was initially sized for this large hydrogen inventory. QUADLOG® will be used for all data acquisition and all electrical safety requirements. All proposed instrumentation will comply with NEC Class I, Division 2, Group B or their usage will be engineered to be intrinsically safe.

In order to reduce cost, implementation of the final system may make use of a previous LH₂ target experiment (SAMPLE) at MIT/Bates Lab. Further, numerical simulations [8] have permitted us to understand the flow dynamics inside the LH₂ absorber. Pressure drop and temperature gradients are simulated and nozzle distributions are optimized.

ACKNOWLEDGEMENTS

Fermilab is operated by Universities Research Association Inc. under contract No. DE-AC02-76CH03000 with the U. S. Department of Energy.

REFERENCES

1. D.M. Kaplan et. al., "Muon-cooling research and development", *Nucl. Instr. and Meth.*, pp. 241-248 (2004).
2. M. Cummings, "Progress in the Liquid Hydrogen Absorber for the MICE Cooling Channel," submitted to PAC'05 proceeding.
3. S. Ishimoto et. al., "Convection-type LH₂ absorber R&D for muon ionization cooling," *Nucl. Instr. and Meth. A* 503, pp. 396-400 (2003).
4. B. Norris, C. Darve, L. Pei., "Reflections on Initial MTA Tests," FNAL/Cryogenic department internal note, 2004.
5. A. Martinez, A. Klebaner, "Results of the MuCool Expander Flow Tests Performed at the Meson Cryogenic Test Facility," FNAL/Cryogenic department internal note, 2004.
6. C. Darve, B. Norris, L. Pei., "Cryogenics for the MuCool Test Area (MTA)," submitted to COOL'05, paper #1086, 2005.
7. C. Darve et al., "Cryogenic Design for a Liquid Hydrogen Absorber System," Proceeding of ICEC19, edited by G. Gistau Baguer and P. Seyfert, Narosa, Grenoble, France, pp. 593-596, 2002.
8. C. Darve et al., "The Liquid Hydrogen System for the MuCool Test Area," in *Advances in Cryogenic Engineering* 49A, edited by J. Waynert et al., Plenum, New York, 2003, pp. 48-55.