



Fermi National Accelerator Laboratory

FERMILAB-Conf-96/375

The Pixel Microtelescope

J. Chapman

*Physics Department, Randall Laboratory
University of Michigan
Ann Arbor, Michigan 48109*

S. Geer

*Fermi National Accelerator Laboratory
P.O. Box 500, Batavia, Illinois 60510*

October 1996

*Published Proceedings of 1996 DPF/DPB Summer Study on New Directions for High Energy Physics
(Snowmass '96), Snowmass, Colorado, June 25-July 12, 1996.*

Disclaimer

This report was prepared as an account of work sponsored by an agency of the United States Government. Neither the United States Government nor any agency thereof, nor any of their employees, makes any warranty, express or implied, or assumes any legal liability or responsibility for the accuracy, completeness or usefulness of any information, apparatus, product or process disclosed, or represents that its use would not infringe privately owned rights. Reference herein to any specific commercial product, process or service by trade name, trademark, manufacturer or otherwise, does not necessarily constitute or imply its endorsement, recommendation or favoring by the United States Government or any agency thereof. The views and opinions of authors expressed herein do not necessarily state or reflect those of the United States Government or any agency thereof.

Distribution

Approved for public release: further dissemination unlimited.

The Pixel Microtelescope *

J. Chapman

Physics Department, Randall Laboratory, Univ. of Michigan, Ann Arbor, MI 48109

S. Geer

Fermi National Accelerator Laboratory, P.O. Box 500, Batavia, IL 60510

ABSTRACT

We describe a vertex and/or tracking detector designed to operate in an environment in which there is a large density of background hits.

I. INTRODUCTION

In this paper we describe the pixel microtelescope concept; a vertexing and/or tracking device designed to operate in an environment in which there is a large density of background hits. In developing the concept we were motivated by estimates of the background fluxes near the interaction point (IP) at a future high energy muon collider [1, 2]. For example, in a silicon layer at a radius of 10 cm there are 14.4 hits/cm² per crossing expected from low energy photon interactions, 0.42 hits/cm² from low energy neutron interactions, and 15.7 hits/cm² from charged tracks, yielding a total hit density of 31 hits/cm² per beam-beam crossing. These particles originate from interactions in shielding cones on either side of the IP, and hence the background tracks tend not to point back to the IP. Furthermore, the mean energy of the interacting photons is expected to be very low, of order 1 MeV. We therefore expect that tracks of interest from the IP will be imbedded in a large flux of soft hits "peppering" the tracking volume. A more complete description of the backgrounds at a muon collider can be found in Ref. [2].

Given the large hit densities expected in the tracking volume at a muon collider, silicon pixels would seem to be a good choice for the detector technology, enabling occupancies to be kept at reasonable levels. Unfortunately, even with low occupancies the total data volume generated from 31 noise hits/cm² per beam-beam crossing, and the fast pattern recognition problems for tracking and vertexing at the trigger level, can be formidable. Furthermore, a healthy safety-factor with respect to the Monte Carlo predicted background occupancies is desirable to allow for inadequacies in the calculations or improvements in the anticipated colliding beam currents. Hence, there is a need to develop detector concepts for which tracking and vertex detectors are blind to very soft hits and/or hits from tracks that do not come from the IP, i.e. a detector that measures the hits from tracks coming from the IP but does not record the 31 noise hits per cm². The silicon pixel microtelescope is intended to be such a device.

II. THE PIXEL MICROT telesCOPe CONCEPT

The idea is to replace a single pixel layer with two layers separated by a small distance, and read them out by taking the AND between appropriate pairs. The distance between the layers is

* Work supported by the U.S. Dept. of Energy under contract DE-AC02-76CH03000 and grant DE-FG02-95ER40899

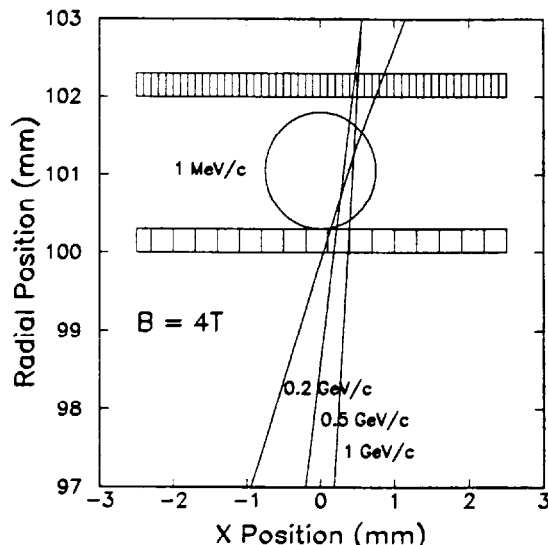

Figure 1: Pixel Micro-telescope geometry, showing trajectories of 0.2 GeV/c, 0.5 GeV/c, and 1 GeV/c tracks coming from the IP and bending in a 4 Tesla field.

optimized so that soft MeV tracks produced in one layer (which are associated with almost 80% of the predicted background hits at a muon collider) curl up in the magnetic field before reaching the second layer. Thus, the pixel micro-telescope is blind to the soft background hits and also blind to tracks that do not come from the IP. In the example shown in Fig. 1 the separation between layers is 2 mm, and to keep the pixel count down and simplify the readout, the top measurement layer has a finer granularity than the bottom confirmation layer.

III. READOUT IDEAS

A pixel microtelescope offers the possibility of rejecting the random hits from low energy photon interactions at the lowest level in the processing. To investigate this possibility we consider a two layered pixel doublet inside a 4 Tesla solenoidal field coaxial with the beam (z) direction. We will take 50 μ m by 300 μ m to be reasonable pixel dimensions, where the smaller dimension provides precise measurements in the bend direction. If the layers are separated radially by 1 cm (2 mm), then in the 4 Tesla field this separation provides a cutoff for tracks below 10 MeV (2 MeV) since they cannot reach the second layer. In the non-bend direction the straight line nature of the track allows easy association between the layers. The large channel count of the pixel arrays demands that some form of serial processing be done. Given the long time between crossings at a muon collider

(10 μ s), the simplest option is to sample the pixel ionization into digital data and to transport this data to external units where the doublet association can be done and the random hits rejected.

As in all pixel systems the readout must be done on circuits bonded to the array of pixels and lying immediately upon the pixels. In this design the logical arrangement for the readout sequence groups the pixels into columns that are one-half of a $50\mu m$ wide pixel and the detector half-length along z . The resulting logical information string is 1024 bits long for a detector composed of 4 pixels arrays on each side of the interaction region. Such a doublet of 2 groups of 4 arrays is shown in Fig. 2. The interconnection between the 4 arrays of a given layer indicates the information transfer along z toward the outer edge. This is done by shifting the information from each pixel to its neighbor and from the last pixel of each array to the first pixel of the next array. A total of 1024 shifts are required which at 8ns/shift consumes 8.192 μ s. During this time the processing of doublets takes place so that pixel hits not matched by hits in both layers are dropped. In addition, the doublet pairs that are retained are sent to linking circuits that associate hits between all doublet layers to form tracks. The trigger processing time would likely take more than one crossing in this scheme requiring that the data stream be pipelined. This is typical of new detectors at high energy colliders.

A couple of special timing features are needed for the process

of shifting pixels if the design is to use simple logic for matching the hits from doublet pairs. The hits that are projective from the IP need to arrive at the comparison circuits simultaneously. This can be assured if the shift process has adequate programmability to permit selection of the first pixel output and the shift rate. An arrow in Fig. 2 marks the location of the pixel in the inner layer that is projective from the last pixel of the outer layer. Only the last array would be programmed in this way. Other arrays would just pass their edge pixel to the input of the next array in the shift stream. An additional requirement is that the shift rate be less in the inner layer if the data at 90° is to arrive simultaneously for both members of the doublet.

If the synchronous shifting scheme is carried out for all doublet layers, the assembly of doublet hits into tracks can be made as though the tracks are 2 dimensional but with the outcome that each track is given an automatic polar angle assignment as it is found. The shift rate would be lower for successively smaller radius layers. This corresponds to the smaller number of pixels in the inner layers.

With $50\mu m$ pixels in the bend direction it is possible to obtain a coordinate point of $25\mu m$ accuracy with very simple circuitry. Fig. 2 also shows one such circuit that contains only gated amplifiers for the pixel signals followed by simple comparators that subdivide each pixel into left and right halves based on the relative size of the signal from its neighboring cells. With a scheme of this type the 256 pixels in the bend direction becomes 512 digital bits to shift out along the column.

IV. SUMMARY

The pixel microtelescope structure and readout architecture described in this paper was motivated by the desire to design a tracking device in which a high density of background hits are removed at the single-hit level during the readout process. Detailed simulations and/or small scale prototyping and measurements are required to access how useful the concept is.

V. REFERENCES

- [1] $\mu^+ \mu^-$ Collider: A Feasibility Study, The $\mu^+ \mu^-$ Collider Collaboration, BNL-52503; Fermilab-Conf.-96/092; LBNL-38946 (1996).
- [2] S. Geer, *Backgrounds and Detector Issues at a Muon Collider*, Fermilab-Conf-96/313, Contribution to these proceedings.

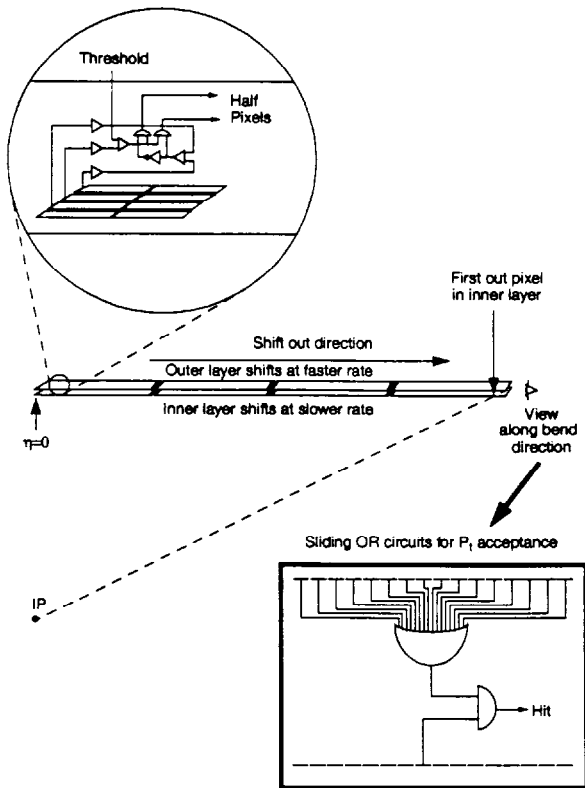

Figure 2: Pixel Micro-telescope readout scheme.